

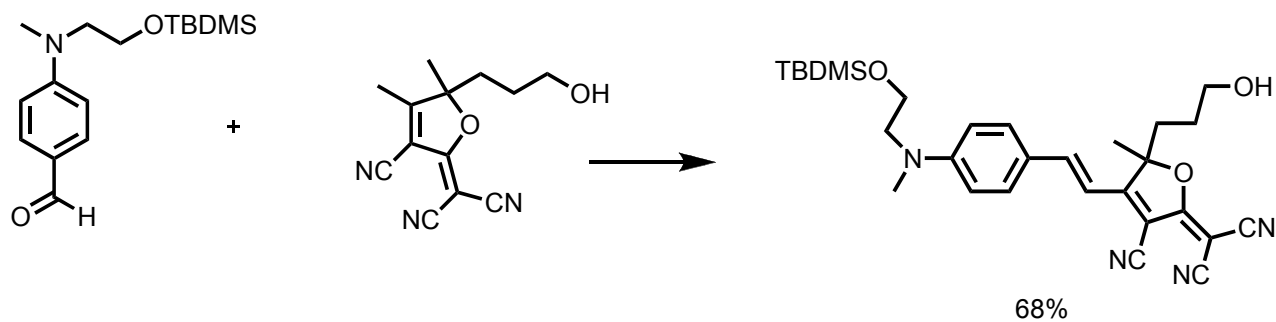

# Triple H-Bonding chromophores

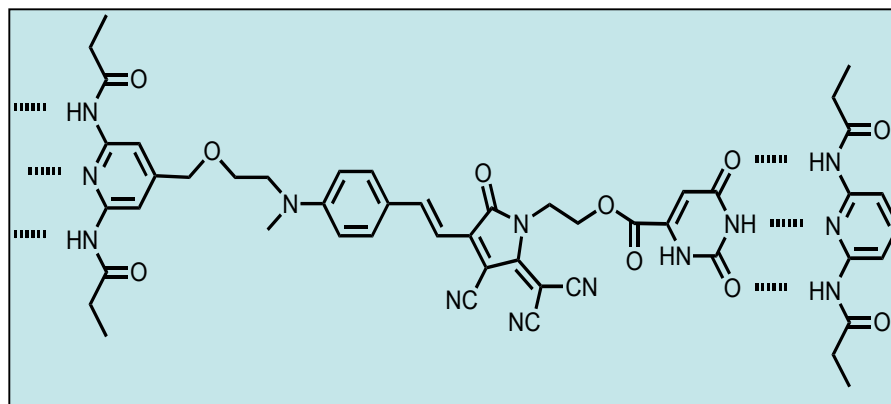

-Hydroxyl substituted  
chromophore

# Synthesis of triple H-bond chromophore

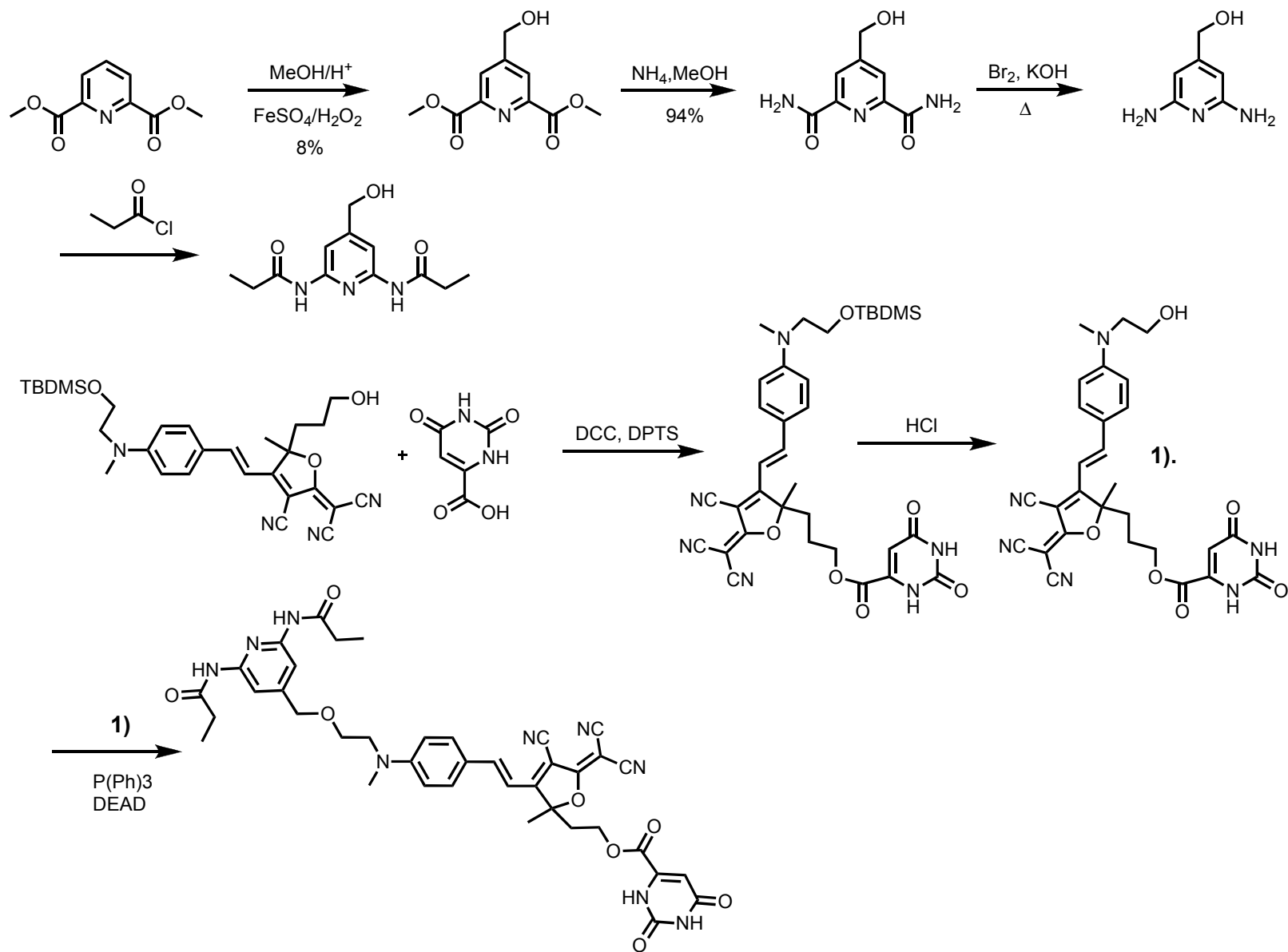

# Self-assembly directing monolayers using chromophores Incorporating H-bonding electron acceptors

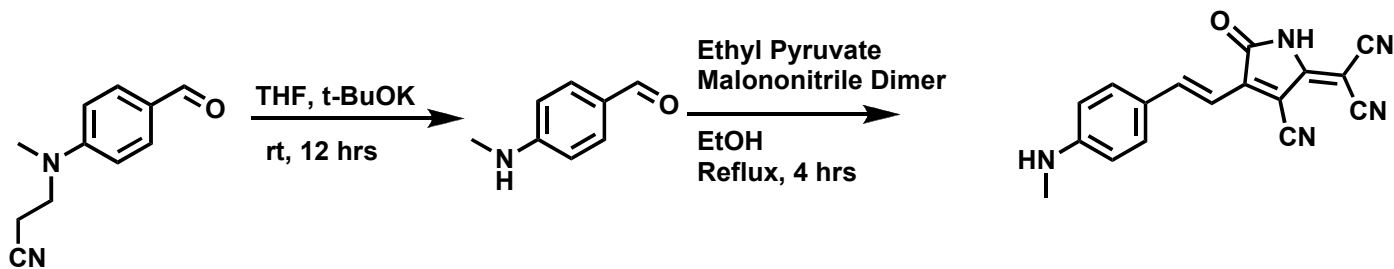
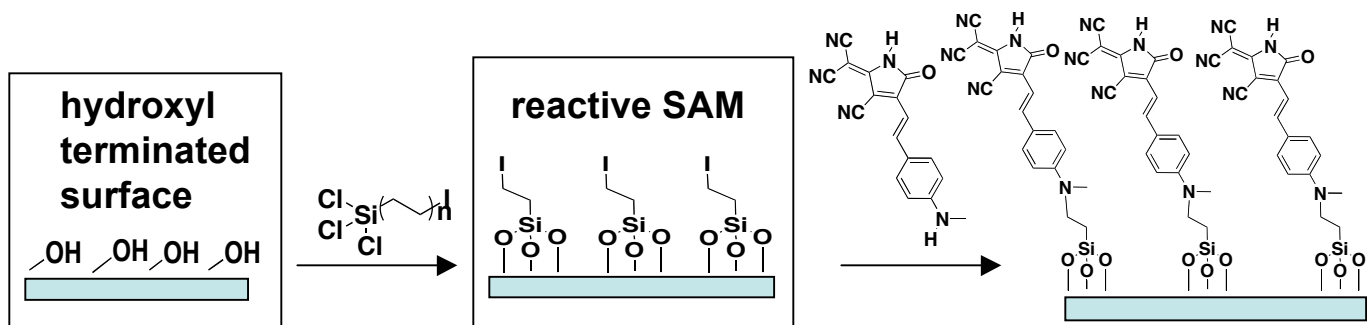

# Synthesis of rigid H-bonding chromophores

