

February, 2002

Genetics 453

Evolutionary Genetics

Molecular Variation

Joe Felsenstein

Department of Genome Sciences
University of Washington, Seattle

email: joe@genetics.washington.edu

Two theories of genetic variation existed before 1966

The Classical view



Hermann Joseph Muller

Most loci will be homozygous for the “wild-type allele” but a few mutants will exist

The Balancing Selection view



Theodosius Dobzhansky

Most loci will be polymorphic due to balancing selection with strong selection

Gel electrophoresis

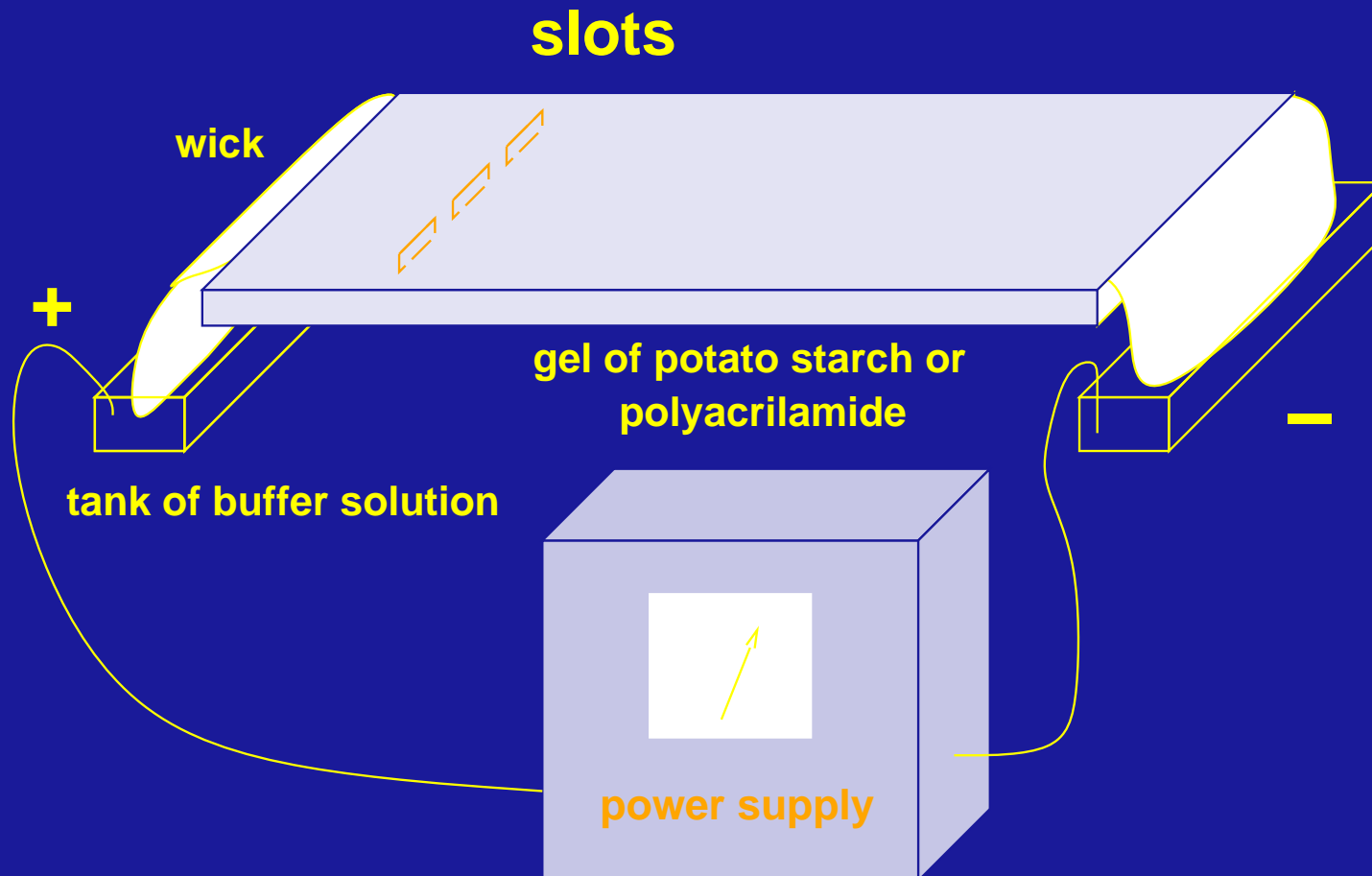

A monomeric enzyme

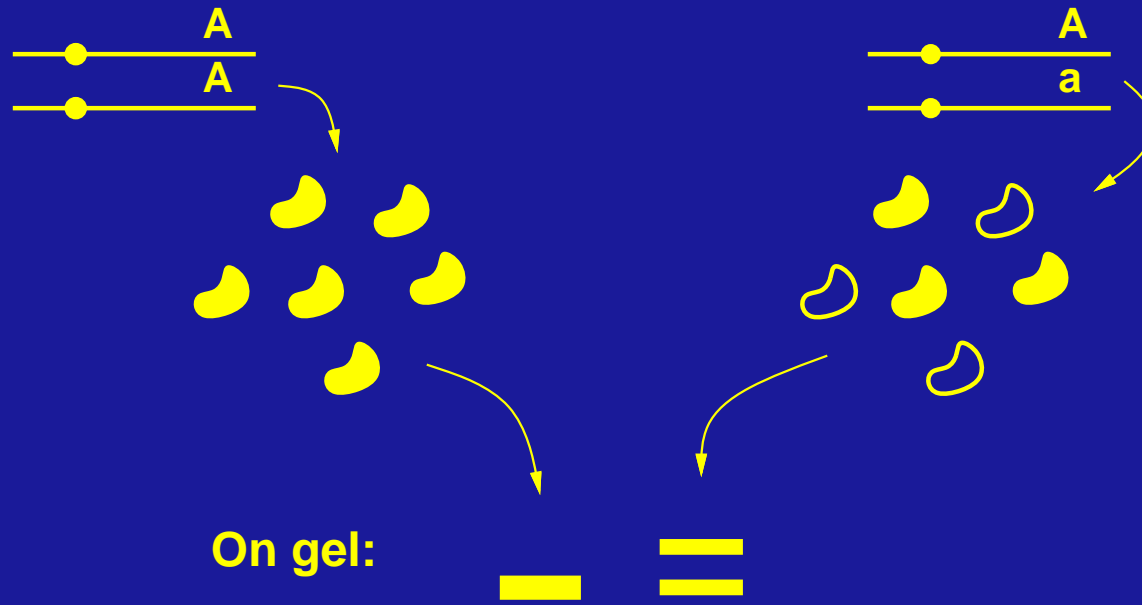

A dimeric enzyme

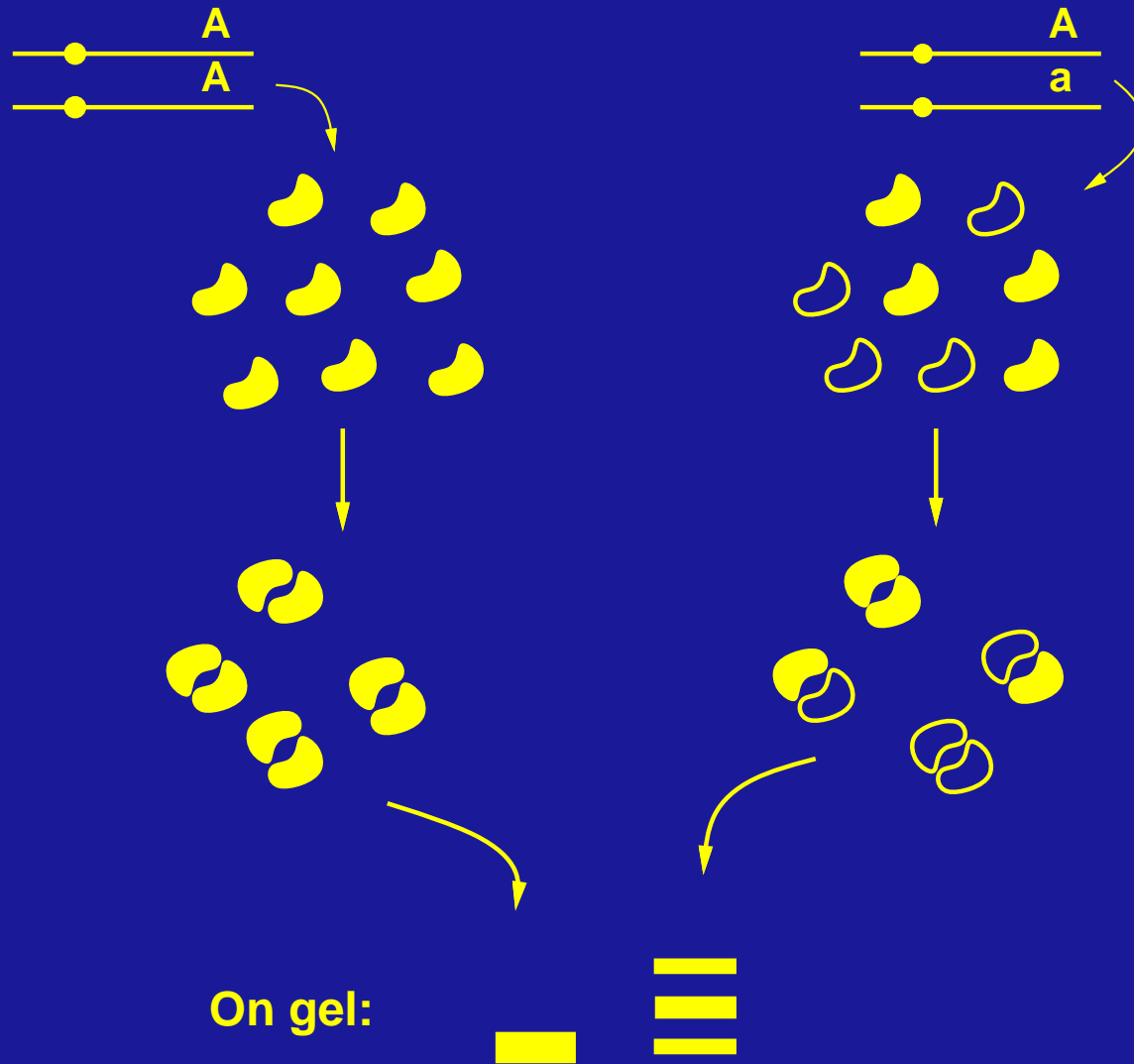

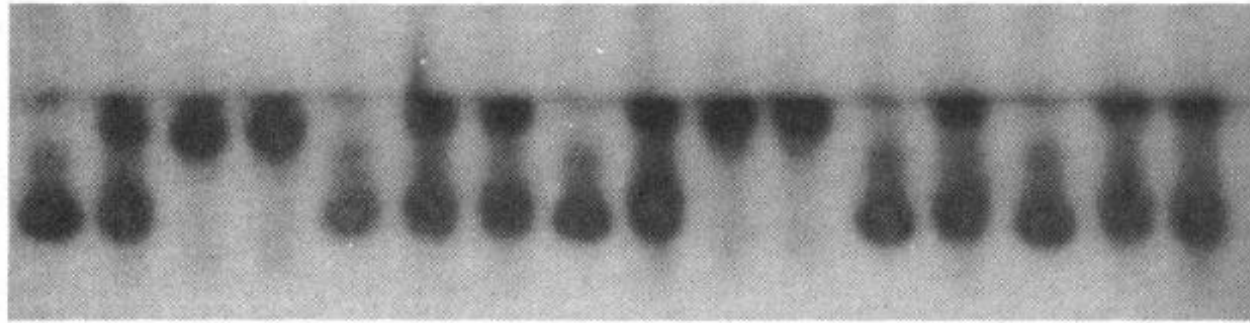

$\frac{S}{S}$ $\frac{F}{S}$ $\frac{F}{F}$ $\frac{F}{F}$ $\frac{S}{S}$ $\frac{F}{S}$ $\frac{F}{S}$ $\frac{S}{S}$ $\frac{F}{S}$ $\frac{F}{F}$ $\frac{F}{F}$ $\frac{S}{S}$ $\frac{F}{S}$ $\frac{S}{S}$ $\frac{F}{S}$ $\frac{F}{S}$

Figure 4. Results of electrophoresis of the enzyme glucose phosphate isomerase-1 from 16 cultured cell lines originating from individuals of the mouse, *Mus musculus*. The gene that codes for the enzyme is *Gpi-1*. In this sample, some individuals are homozygous for an allele (S) corresponding to a slow-migrating enzyme, some are homozygous for an allele (F) corresponding to a fast-migrating enzyme, and the rest are heterozygous (F/S). The inferred genotypes of the cell lines are indicated beneath the enzyme bands. This enzyme is a monomer, so the heterozygotes exhibit two enzyme bands of differing mobility. (Courtesy of S. E. Lewis and F. M. Johnson.)



Richard Lewontin, about 1980

Lewontin, R. C. and J. L. Hubby. 1966. A molecular approach to the study of genic heterozygosity in natural populations. II. Amount of variation and degree of heterozygosity in natural populations of *Drosophila pseudoobscura*. *Genetics* **54**: 595-609.

Measures of variability with multiple loci

Lewontin and Hubby (Genetics, 1966) suggested two measures of variability: polymorphism and heterozygosity.

Polymorphism is the fraction of all loci that have the most common allele less than 0.95 in frequency (i.e. all the rarer alleles together add up to less than 0.05).

Heterozygosity is the estimated fraction of all individuals who are heterozygous at a random locus.

Computing the average heterozygosity

If p_i is the frequency in the sample of allele i at a locus, then the heterozygosity for that locus is estimated by taking the sum of squares of the gene frequencies (thus estimating the homozygosity) and subtracting from 1:

$$H = 1 - \sum_{i}^{\text{alleles}} p_i^2$$

An example:

locus 1		1		
locus 2		1		
locus 3		0.8	0.2	
locus 4		0.94	0.04	0.02

The heterozygosities are calculated as:

locus 1		$1 - 1^2 = 0$
locus 2		$1 - 1^2 = 0$
locus 3		$1 - (0.8^2 + 0.2^2) = 0.32$
locus 4		$1 - (0.94^2 + 0.04^2 + 0.02^2) = 0.1144$

The average heterozygosity in this example is

$$H = (0 + 0 + 0.32 + 0.1144)/4 = 0.1086$$

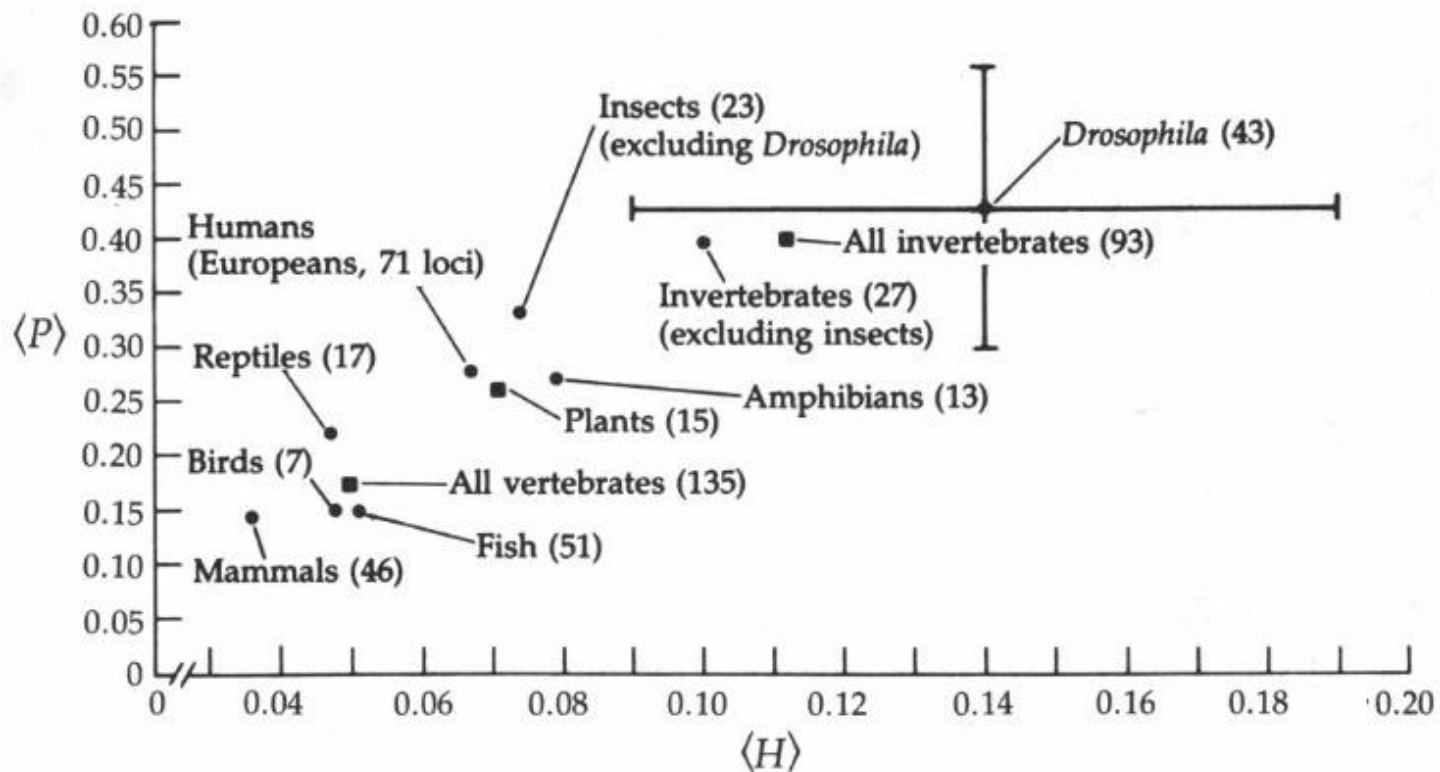

Figure 10. Estimated levels of heterozygosity ($\langle H \rangle$) and proportion of polymorphic genes ($\langle P \rangle$) derived from allozyme studies of various groups of plants and animals. The number of species studied is shown in parentheses beside each point. Squares denote averages for plants, invertebrates, and vertebrates. The bars across the *Drosophila* point show the range of H and P within which 68% of the *Drosophila* species fall. Other groups would have similarly large bars. (Data from Nevo 1978.)



Motoo Kimura and family, 1966



Tomoko Ohta, recently

Kimura, M. 1968. Evolutionary rate at the molecular level. *Nature* **217**: 624-626.

Kimura, M., and T. Ohta. 1971. Protein polymorphism as a phase of molecular evolution. *Nature* **229**: 467-469.

Neutral Mutation Theory

Kimura, 1968; Kimura and Ohta, 1971

assume: population size N , rate u of neutral mutations, all different

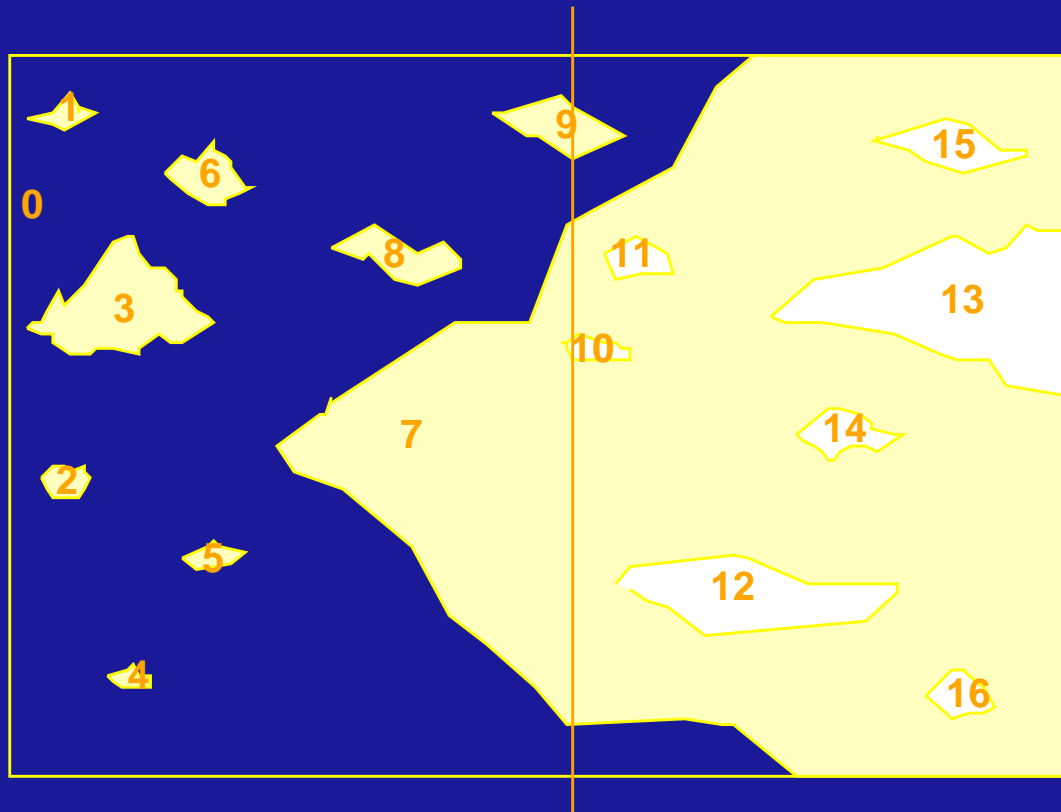

Heterozygosity
at any point is
expected to be

$$\frac{4Nu}{4Nu + 1}$$



James F. Crow, about 1990

Kimura, M., and J. F. Crow. 1964. The number of alleles that can be maintained in a finite population. *Genetics* **49**: 725-738.

Expected Heterozygosity with Neutral Mutation

In a random-mating population with neutral mutation, a fraction F of the pairs of copies will be homozygous. Suppose all mutations create completely new alleles, and the rate of these neutral mutations is m

diploid population of size N

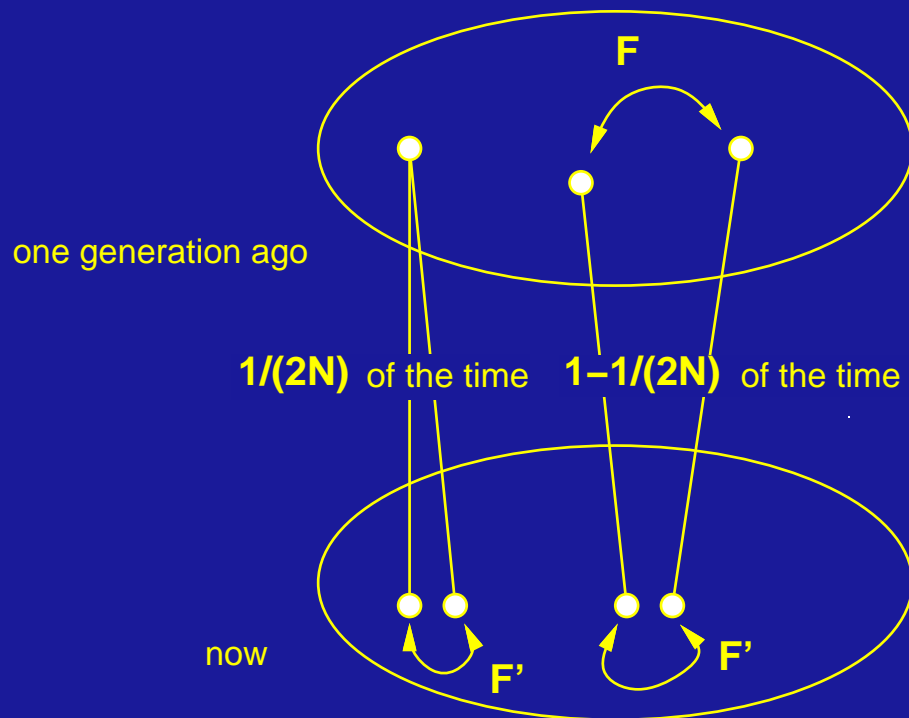

To be identical, both copies must not be new mutants, and the probability of this is $(1-m)^2$

So if we have settled down to an equilibrium level of heterozygosity, $F' = F$, so that

$$F = (1-m)^2 \left[\frac{1}{2N} \times 1 + \left(1 - \frac{1}{2N}\right) F \right]$$

which is easily solved to give

$$F = \frac{(1-m)^2 \left(\frac{1}{2N} \right)}{1 - (1-m)^2 \left(1 - \frac{1}{2N} \right)}$$

or to good approximation: heterozygosity is:

$$F = \frac{1}{1 + 4Nm}$$

$$1-F = \frac{4Nm}{1 + 4Nm}$$

Heterozygosity in Marine Invertebrates (James Valentine, 1975)

species	which is a	samples/locus	no. loci	Het.
<i>Asterias vulgaris</i>	Northern sea star	19-27	26	1.1
<i>Cancer magister</i>	Dungeness crab	54	29	1.4
<i>Asterias forbesi</i>	Common sea star	19-72	27	2.1
<i>Lyothyrella notorcadensis</i>	brachiopod	78	34	3.9
<i>Homarus americanus</i>	lobster	290	37	3.9
<i>Crangon negricata</i>	shrimp	30	30	4.9
<i>Limulus polyphemus</i>	horseshoe crab	64	25	5.7
<i>Euphausia superba</i>	Antarctic krill	124	36	5.7
<i>Upogebia pugettensis</i>	blue mud shrimp	40	34	6.5
<i>Callinassa californiensis</i>	ghost shrimp	35	38	8.2
<i>Phoronopsis viridis</i>	horseshoe worm	120	39	9.4
<i>Crassostrea virginica</i>	Eastern oyster	200	32	12.0
<i>Euphausia mucronata</i>	small krill	50	28	14.1
Asteriodea (4 spp.)	deep sea stars	31	24	16.4
<i>Frielea halli</i>	brachiopod	45	18	16.9
<i>Ophiomusium lymani</i>	large brittlestar	257	15	17.0
<i>Euphausia distinguenda</i>	tropical krill	110	30	21.5
<i>Tridacna maxima</i>	giant clam	120	37	21.6

An interesting case: *Limulus polyphemus*



Carboniferous (300 mya)

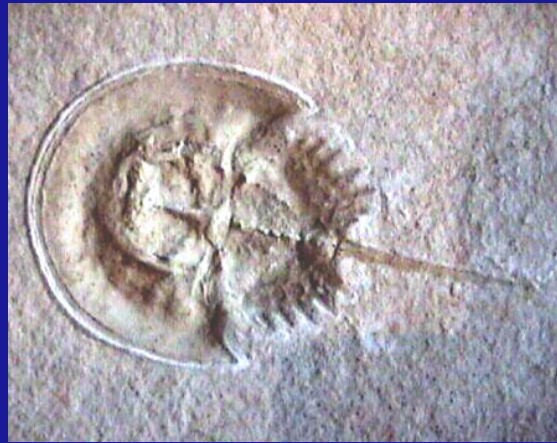

Jurassic (155 mya)



today

Selander, R.K., S.Y. Yang, R.C. Lewontin, W.E. Johnson. 1970. Genetic variation in the horseshoe crab (*Limulus polyphemus*), a phylogenetic "relic." *Evolution* 24:402-414.

An Interesting Case

Northern elephant seal
Mirounga angustirostris



Southern elephant seal
Mirounga leonina



Northern elephant seal: Population in 1890's: 2-20 ?

Population today: 150,000 or so ("help! there's a monster dying on my beach")

Bonnell, M.L., and R.K. Selander. 1974. Elephant seals: genetic variation and near extinction. *Science* **184**: 908-909.

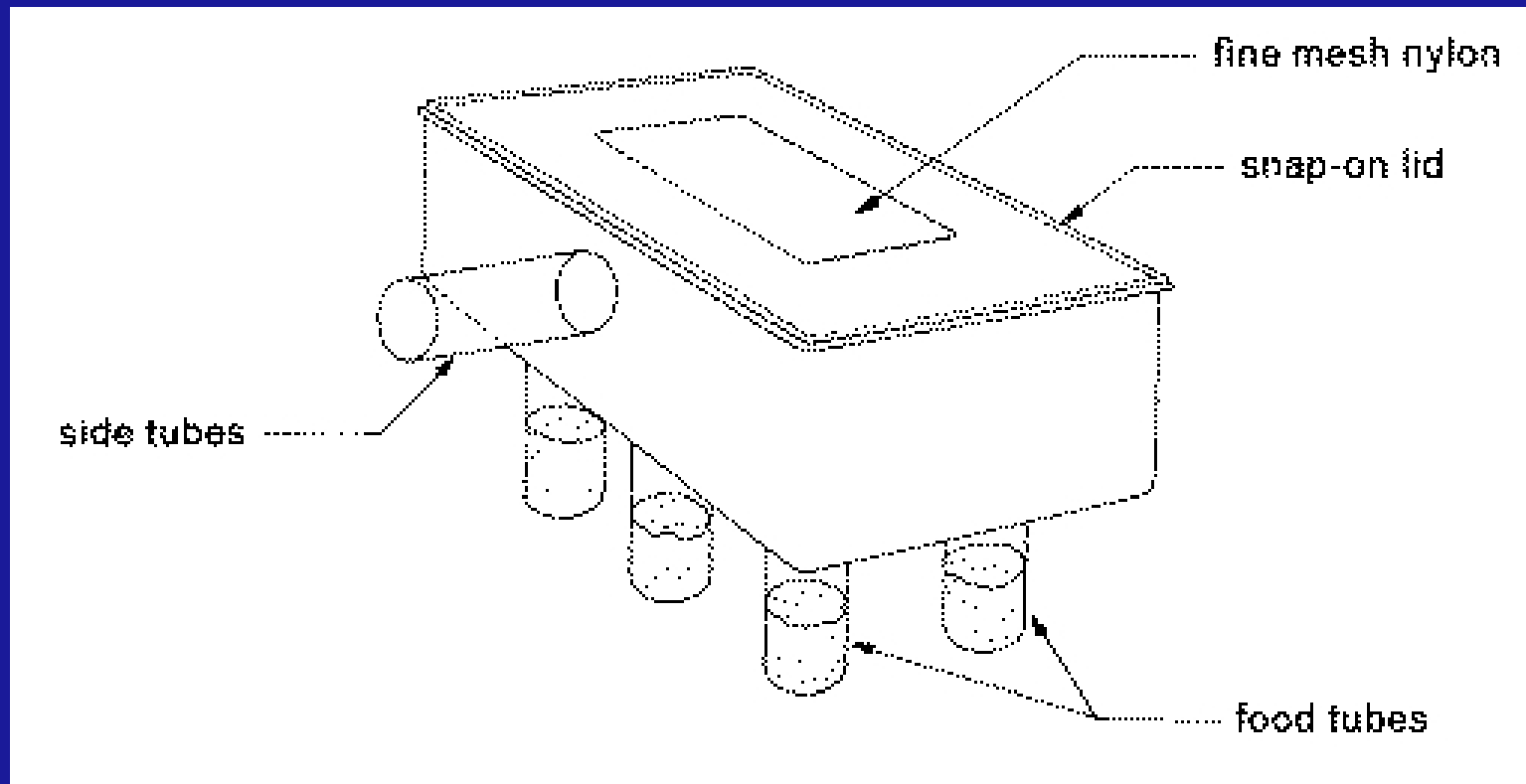

A "population cage" for *Drosophila*

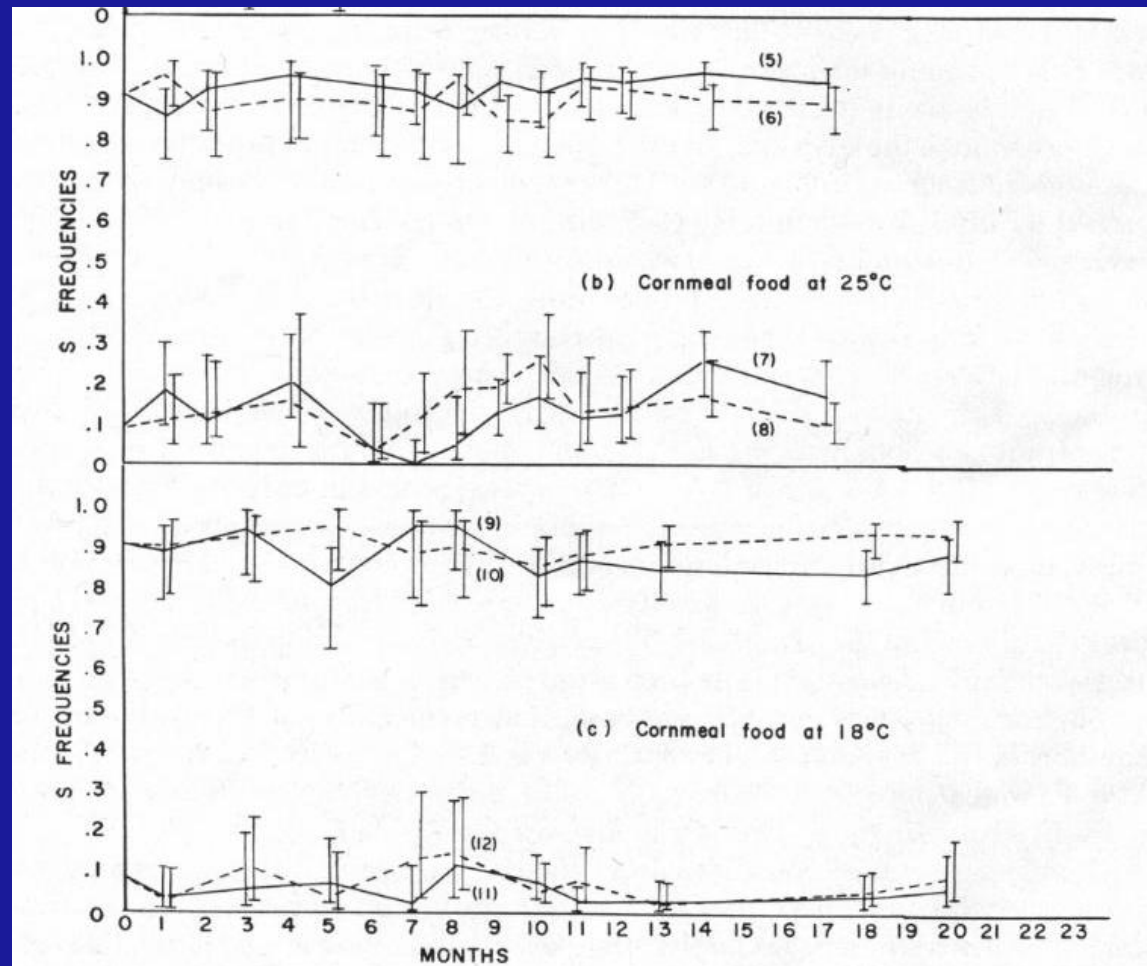

FIGURE 1.—Gene frequency changes in population cages at two different temperatures (18°C and 25°C) with two different foods (SPASSKY's and cornmeal). Vertical lines represent 95% confidence intervals.

Yamazaki, T. 1971. Measurement of fitness at the esterase-5 locus in *Drosophila melanogaster*. *Genetics* **67**: 579-603.

Explaining Electrophoretic Polymorphisms

Can do it either way:

By neutral mutation If $H = 0.15$ then if $N_e = 1,000,000$ we need $4N_e\mu = 0.176$ to predict this, so that implies $\mu = 4.4 \times 10^{-8}$. So we can explain the level of variation by a neutral mechanism.

By selection To be effective in a population with $N_e = 1,000,000$ selection would need to be big enough that $4N_e s > 1$ so $s > 1/4,000,000$ which is quite small, and impossible to detect in laboratory settings.

DNA sequencing reveals a similar picture



Marty Kreitman

Kreitman, M. 1983. Nucleotide polymorphism at the alcohol-dehydrogenase Locus of *Drosophila melanogaster*. *Nature* **304**: 412-417.

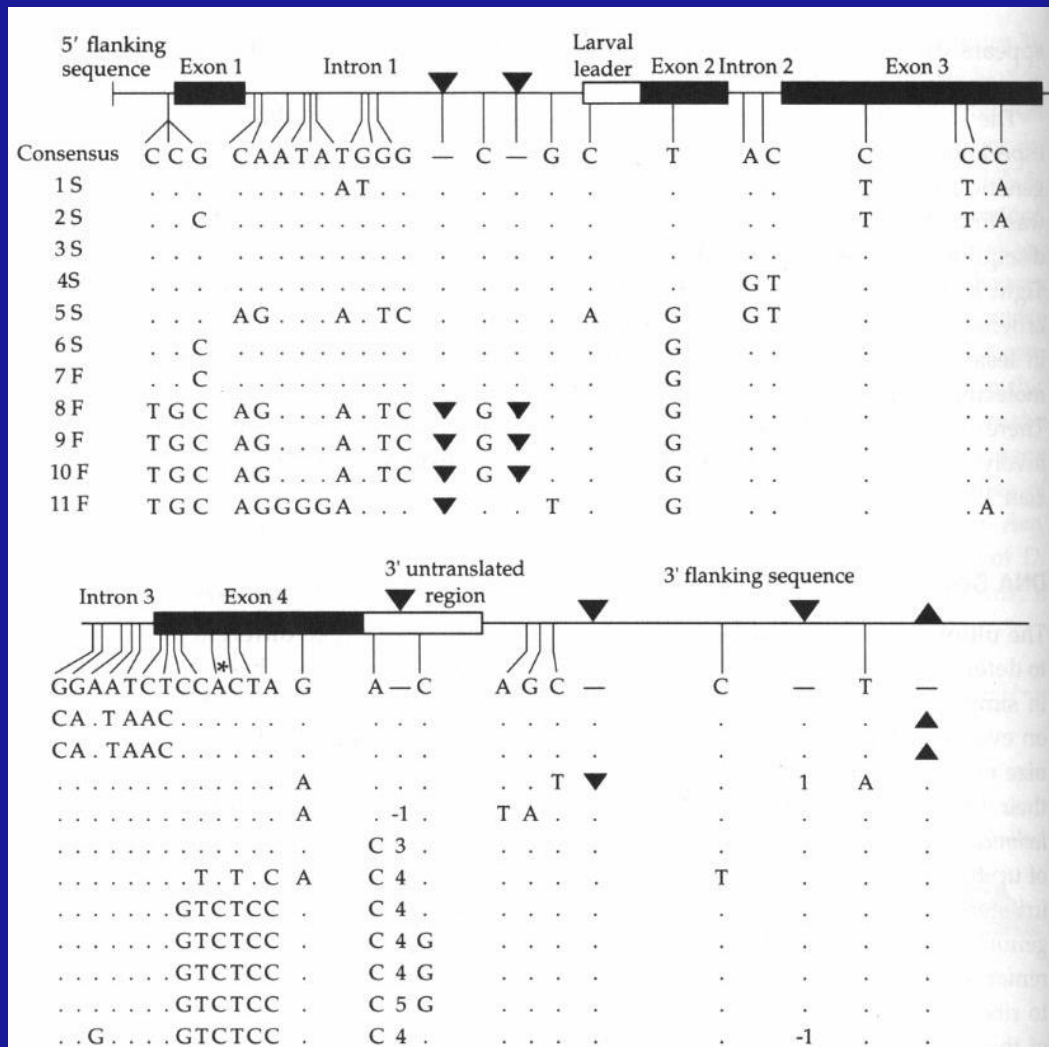

Figure 4. Polymorphic nucleotide sites among 11 alleles of the alcohol dehydrogenase gene of *Drosophila melanogaster*. The first line gives a consensus sequence for *Adh* at sites that vary; subsequent lines give the nucleotides from each copy for the polymorphic sites. A dot indicates that the site is identical to the consensus sequence. The triangles indicate sites of insertion or deletion relative to the consensus sequence. The star in exon 4 indicates the site of the amino acid replacement (lysine for threonine) responsible for the *fast-slow* mobility difference in the *Adh* protein. (After Kreitman 1983.)

This freeware-friendly presentation prepared with

- Linux (operating system)
- PDFLaTeX (mathematical typesetting and PDF preparation)
- Idraw (drawing program to modify plots and draw figures)
- Adobe Acrobat Reader (to display the PDF in full-screen mode)

(except that we had to use Microsoft Windows to project this as the X server I have in Linux is not too great)