

Seating Marshal #18

- I. **Check-in:** Please check in at the Touchdown Terrace. Brunch will be served from 11:00 a.m. – 12:30 p.m. You may review your ceremony positions and instructions on the field, but please return to the north lineup area on the Outdoor Practice Field (see Faculty Lineup Chart NE) by 1:00 p.m.
- II. **Procession (see diagram, p. 2):** The procession begins promptly at 1:30 p.m. Marching in front of the faculty procession (see Marshal Lineup Chart), you will arrive at position #18. You will be seating candidates in the *even-labeled* rows, 21 per row, beginning in doctoral section #2 and moving back. Doctoral Marshal #18, arriving with the doctoral candidates, will assist you.

The doctoral marshal feeds the students into a row. You should be positioned about 10 ft. from the current row being “fed.” Hold the students back and, once a row has been filled, count out 22 students for the next row. Doctoral candidates will arrive first, followed by master’s candidates. If you run out of seats, direct students laterally to available seats in their degree section. When the bachelor candidates arrive, permit the College Marshals leading them to pass by and proceed to the stage. Be sure that the final row of bachelor candidates has equal numbers on the north and south sides.

After the candidates have been seated, the Deans Party, then the President’s Party, will process to the stage. As the President’s Party walks up the center aisle, move up one of the outside aisles toward the stage. When the entire President’s Party has reached the stage, proceed up the north ramp to your seat (see diagram, page 2).

- III. **Doctoral march to the stage (see diagram, page 3):** After the commencement address, University Marshal Moore will announce the presentation of the various degrees. Move to “n” shown on the *doctoral march* diagram at this time. Make sure the two stanchions near the ramps (shown in green) are positioned according to the doctoral march diagram. (After the doctoral march, reposition the stanchions according to the master’s march diagram - see diagrams, page 3)

Direct candidates to exit their rows as shown on the doctoral march diagram. As each row exits, move back to direct the next row. As candidates return from the stage, reseal them. (Students wearing purple and gold buttons signal the start of a new row – see diagram.) At the completion of the doctoral degrees, move to new position “n,” shown on the *master’s march* diagram.

- IV. **Master’s march (see diagram, page 3):** From master’s position “n” direct candidates in master’s section #2 to exit their rows as shown on the master’s march diagram. A master’s marshal will assist you. Seat candidates as they return from the stage. Students wearing purple and gold buttons signal the start of a new row (see diagram). At the completion of the master’s degrees, move to position “n,” as shown on the *bachelor march* diagram.
- V. **Bachelor march (see diagram, page 4):** At position “n” direct candidates to exit their rows as shown on the bachelor march diagram. As each row exits, move back to direct the next row. Other marshals will reseal the candidates as they return from the stage. When the last row of candidates has exited, move to position “J” (see diagram, page 2).
- VI. **Recessional (see diagram, page 2):** At position “J,” direct faculty exiting the stage to the center aisle. Be alert for slips or stumbles. As the last members of the faculty leave the stage, follow them out of the stadium to the area in back of the Touchdown Terrace. From there you may disperse with the rest of the faculty.

Processional and Recessional Positions

Blue line = student line of march

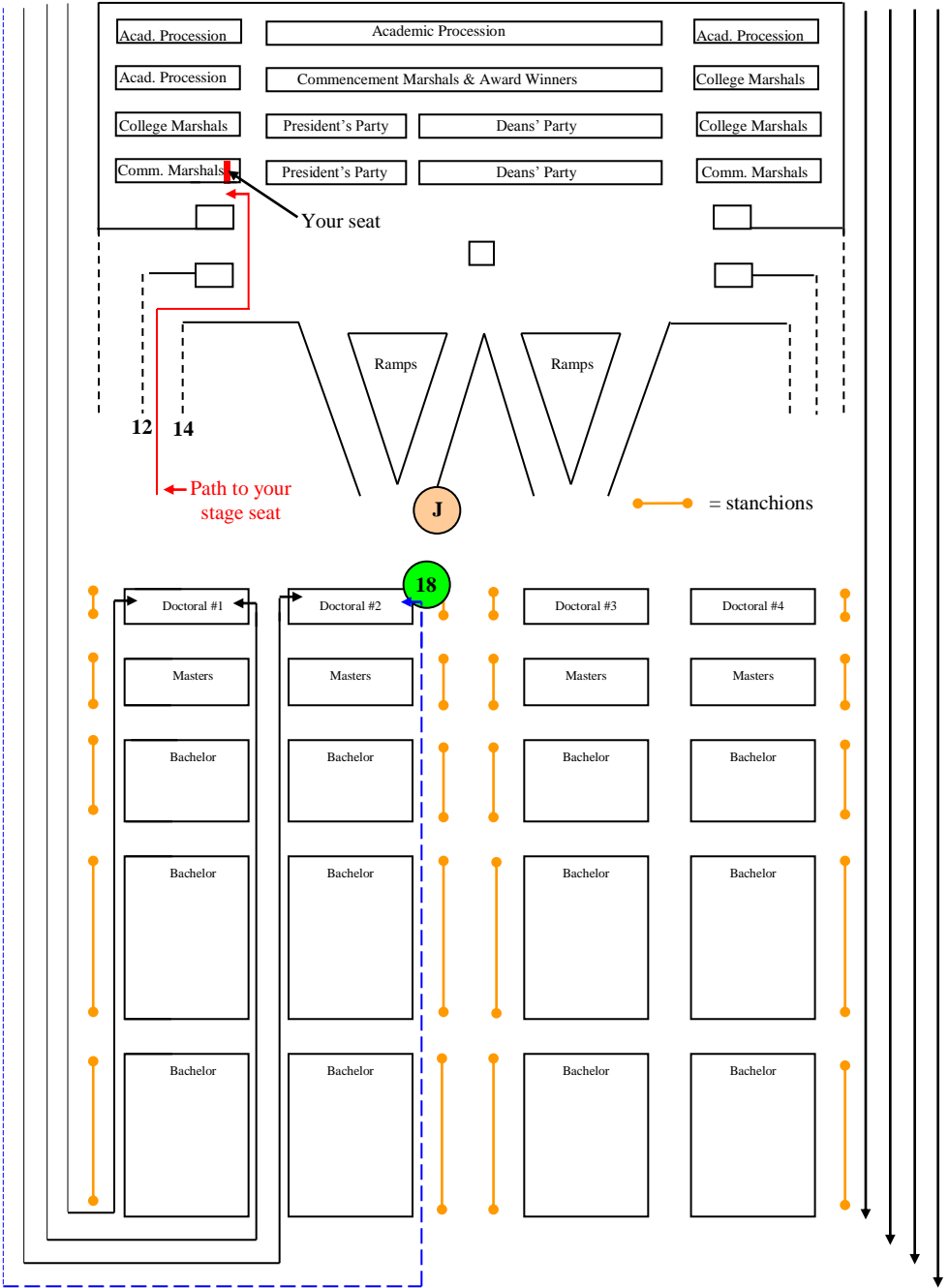

DOCTORAL MARCH DIAGRAM

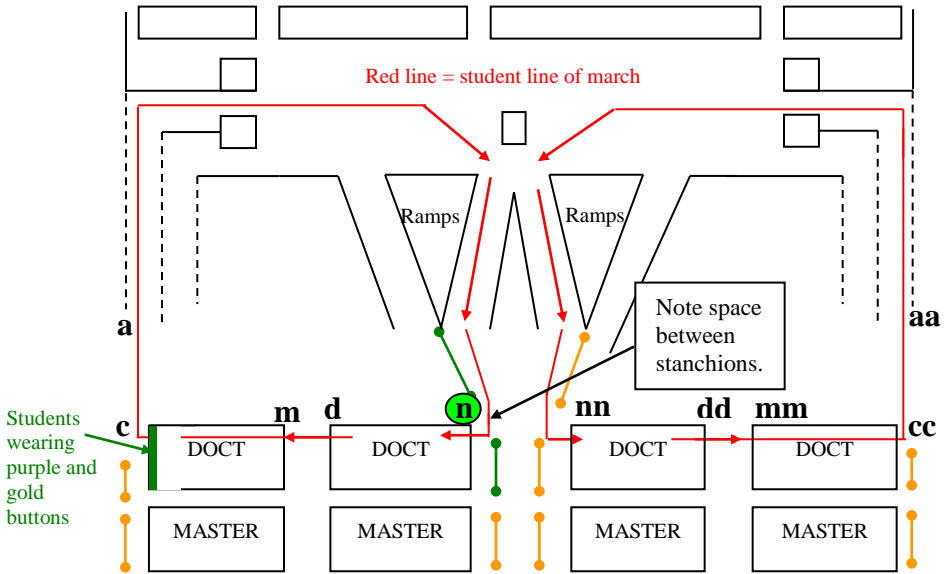

MASTER'S MARCH DIAGRAM

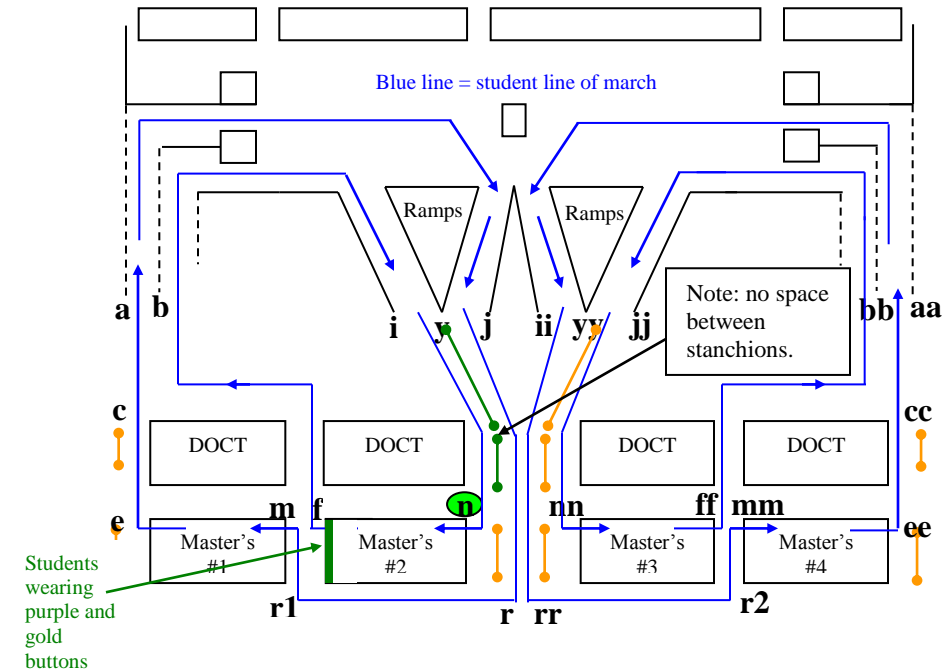

BACHELOR MARCH

