

Optical Sources

Wei-Chih Wang

Department of Mechanical Engineering

University of Washington

ME557

When sub-atomic particles were first discovered in 1897, they were thought to orbit the nucleus like planets orbit the sun. Unfortunately, this is the atomic model still taught in many secondary schools. In the mid-20th. century, it was discovered that the structure of the electronic shells was somewhat more complex consisting of:

- up to at least seven capital-lettered shells (1=K, 2=L, 3=M, 4=N, 5=O, 6=P, 7=Q)
- up to at least 4 small-lettered orbitals (s, p, d, f)
- each orbital is further divided into sub-orbitals: s has 1, p has 3, d has 5, f has 7
- each of these sub-orbitals can accommodate two electrons.

Electromagnetic waves travel through space at a single **constant speed**, $c = 3.00 \times 10^8 \text{ m sec}^{-1}$ sometimes referred to as the 'speed of light' although it is, in fact, the speed of **all** electromagnetic radiation. The wavelength and frequency of electromagnetic radiation are related to the velocity by the equation:

$$c = \lambda \nu$$

Electromagnetic waves are a form of energy and the energy varies with wavelength and frequency according to the relationship:

$$E = h\nu = hc / \lambda \quad (h = \text{Planck's constant} = 6.63 \times 10^{-34} \text{ J s})$$

i.e. **energy** is **directly proportional to frequency** (high frequency = high energy and vice-versa) but **inversely proportional to wavelength** (long wavelength = low energy and vice-versa).

The entire range of electromagnetic radiation from the **lowest energy** (low frequency, long wavelength) to the **highest energy** (high frequency, short wavelength) is called the **electromagnetic spectrum**.

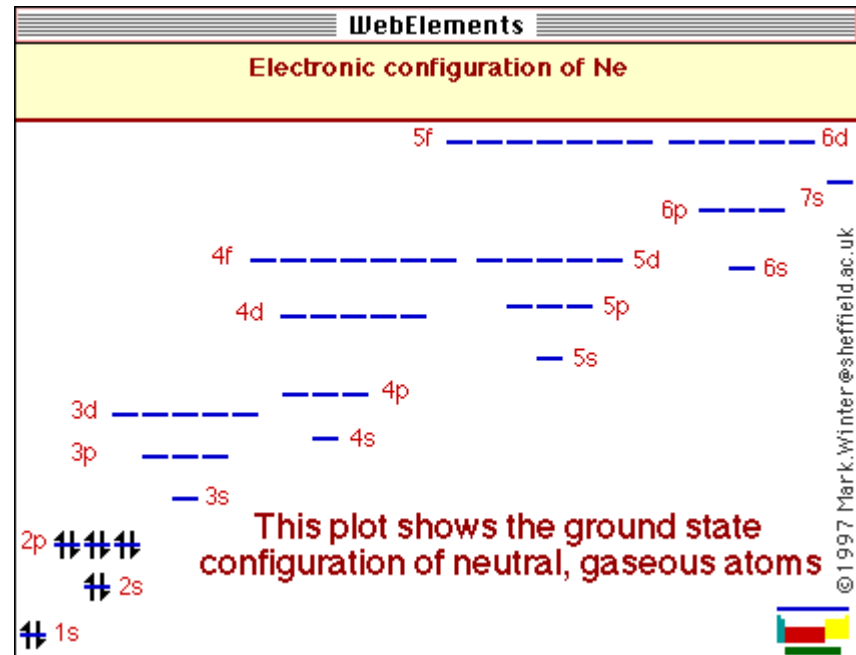
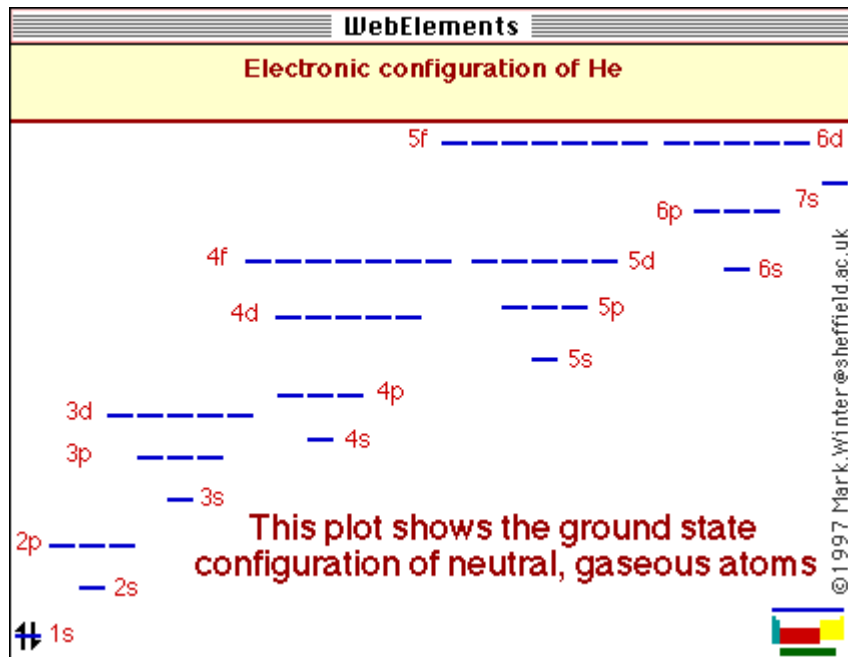

,Helium (He) with its two electrons, has filled its s-

The Hydrogen Emission Spectrum

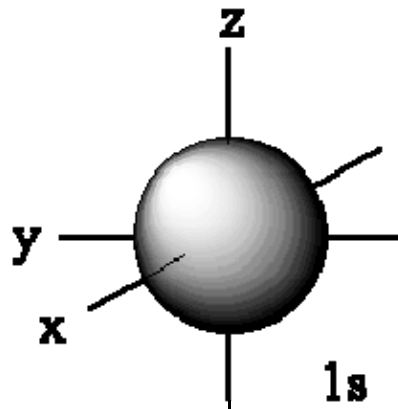

The hydrogen emission spectrum is a **line spectrum**, i.e. only particular frequencies (wavelengths, energies) are observed.

The Hydrogen Emission Spectrum

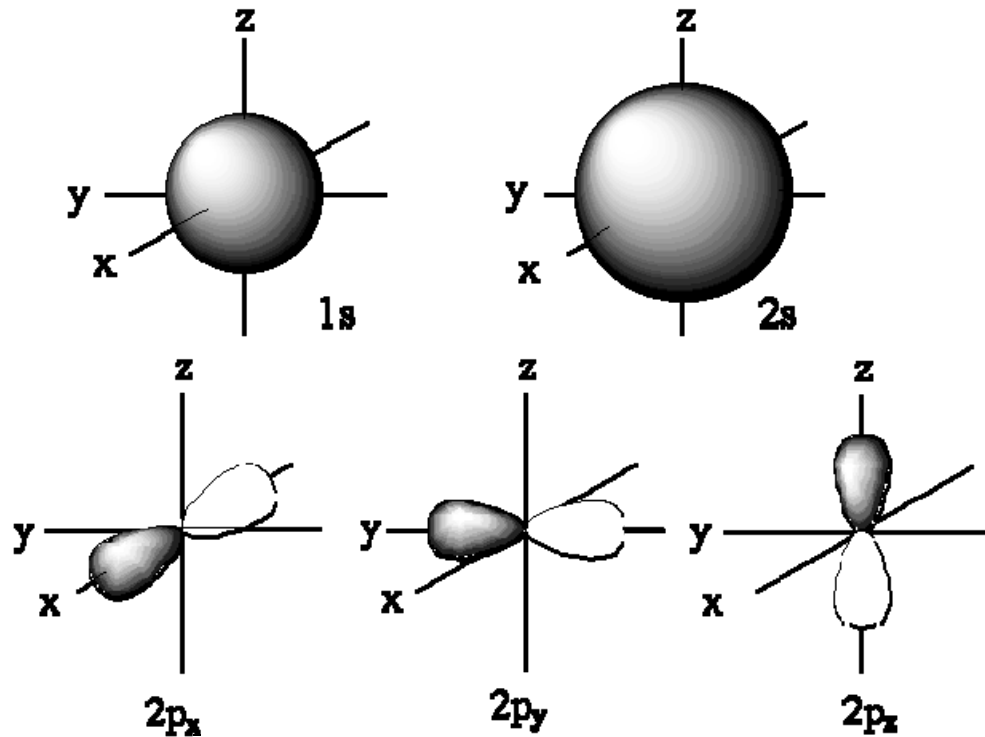

The lines in the hydrogen emission spectrum are found to be grouped into **line series**: Lyman (Ultra Violet), Balmer (Visible), Brackett, Paschen and Pfund (all in the Infra Red region).

WHAT IS GOING ON HERE?

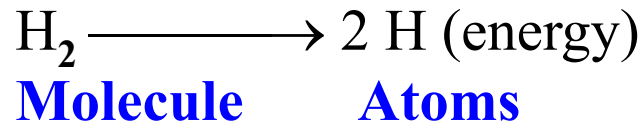

Atom in 'excited state', i.e. with increased Energy

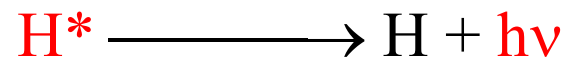

The **excited** atom returns to the 'normal' state (**ground state**) by releasing the excess energy as **electromagnetic radiation** of energy ($E = h\nu$) corresponding to the energy difference between the ground state and the excited state.

The fact that the hydrogen emission spectrum is a line spectrum – **only radiation of very specific frequencies being emitted** – means that only excited states of very specific energies are being formed.

By inspection an empirical mathematical formula – the **Rydberg Equation** - was found which predicted the position of all the lines in the spectrum:

$$\frac{1}{\lambda} = R_H \left[\frac{1}{n_1^2} - \frac{1}{n_2^2} \right]$$

n_1 and n_2 are integers and $n_2 > n_1$

Rydberg Constant for H
 $= 1.0974 \times 10^{-2} \text{ nm}^{-1}$

When $n_1 = 1$ and $n_2 = 2, 3, 4 \dots \infty$ the positions of the lines in the Lyman (UV) series is predicted. The Balmer (visible) series is predicted by $n_1 = 2, n_2 = 3, 4, 5$ etc. The Brackett, Paschen and Pfund series (IR) are predicted by $n_1 = 3, n_1 = 4$ and $n_1 = 5$ respectively.

**A theory was proposed to account for
these observations.**

The Bohr Theory of Atomic Structure
– Quantum Mechanics

1. The energy of electrons in atoms is

Broadband light source

Figure 1 Spectra from Common Sources of Visible Light

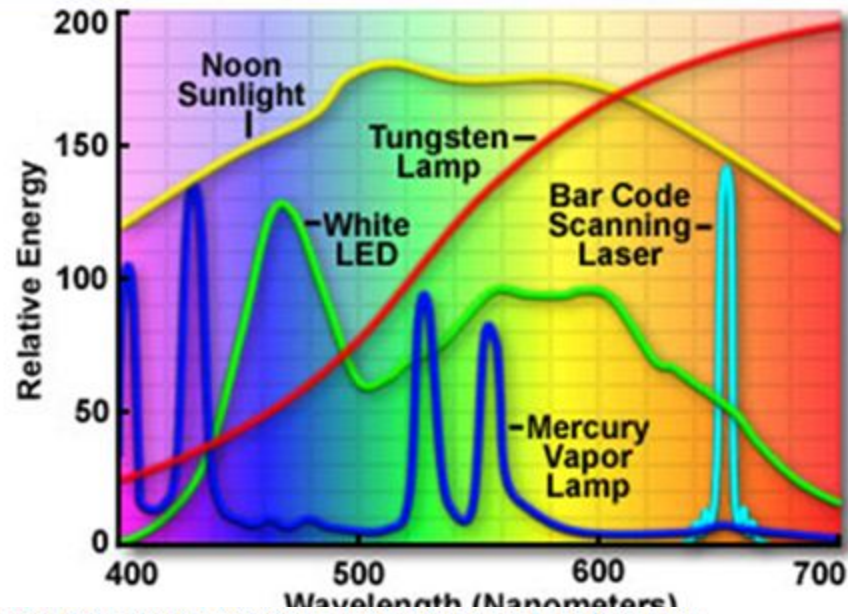
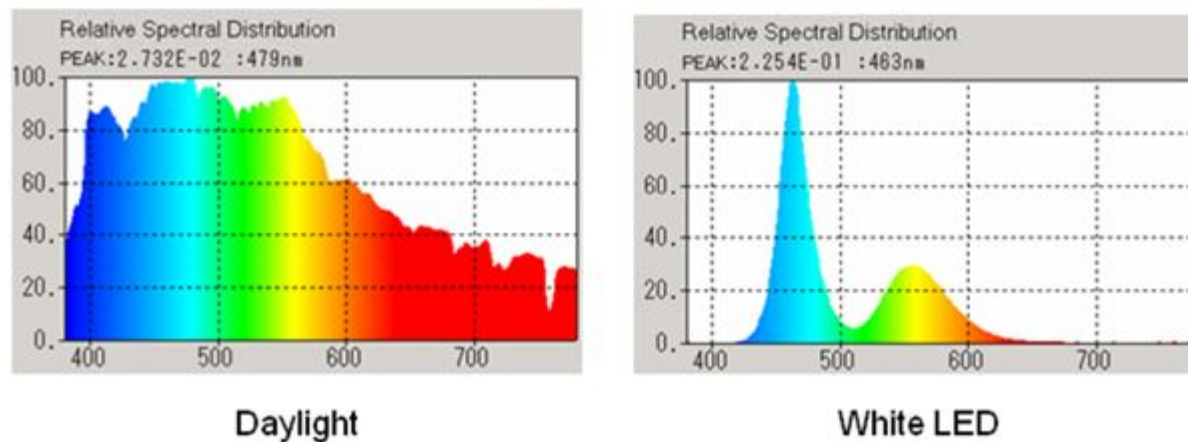

Figure 2 Spectral Power Distributions of Daylight and a White LED



(Source: Konica Minolta Sensing Americas)

Light Sources

Broadband light sources: incoherent, intensity distribution
no uniform across all spectrum (white light source)

Hologen: 250-1100nm

Krypton: 350-1700nm

Xenon (Xenon) : 180- 2200nm

Deuterium: 190-500nm

Mercury+Argon: 253.65 –1013.98nm

Deuterium + halogen: 190-900nm

LED: range from 400 to 1800nm

Tungsten+ Hologen: 350-2000nm

Narrow band light source:

Laser- 200 to 1800nm

Incandescent Filament Lamps

In conventional filament lamps or light bulbs, electric current is passed through a coiled tungsten filament, contained in a glass envelope that is filled with an

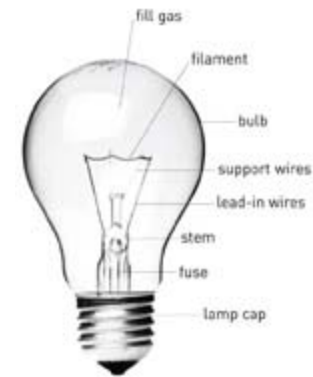

Halogen

Halogen lamps are also filament lamps. However, halogen is added to the fill gas to prevent evaporated tungsten from



Halogen Spectrum

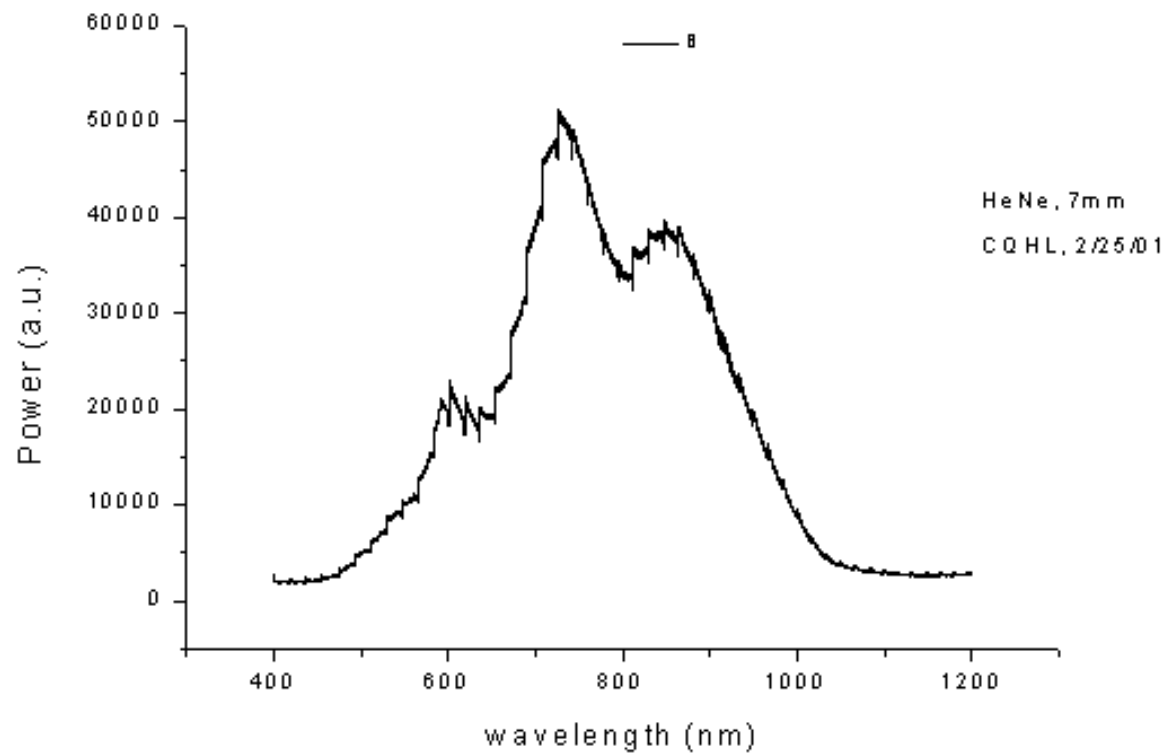

Gas discharged lamp

In a gas discharge lamp, once a sufficient voltage is applied, electrons are emitted from a heated electrode, creating a plasma or a gas capable of



high intensity discharge lamp (e.g. metal halide lamp)

High pressure gas discharge lamps emit radiation directly as visible light. In this type of lamp the combination of different element atoms in the hot gas

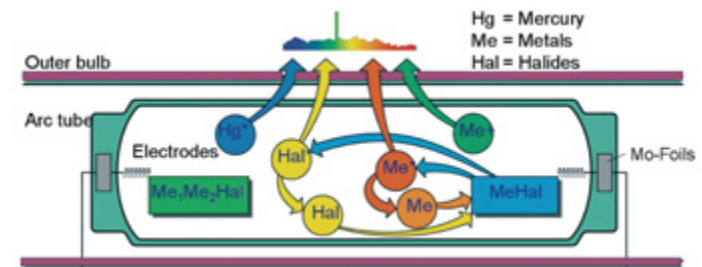

low-pressure mercury gas discharge fluorescent lamp

Ultraviolet photons have the capability to excite fluorescent powders, which are coated on the inside of the tube with a

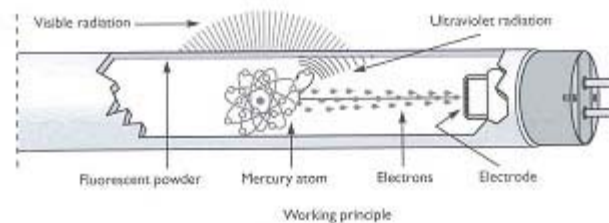

LED lecture

Wei-Chih Wang
University of Washington

Linear and Nonlinear electronics

cur
ren
t

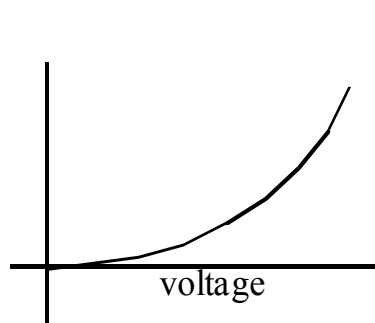

Vacuum tube
(i.e. type 2A3)

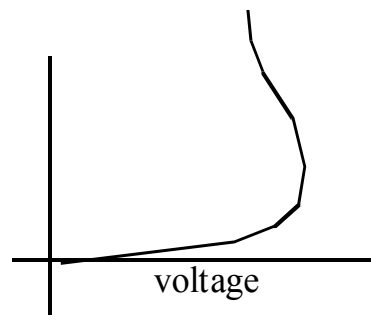

Thermistor
(large negative
temperature
coefficient of
resistivity)

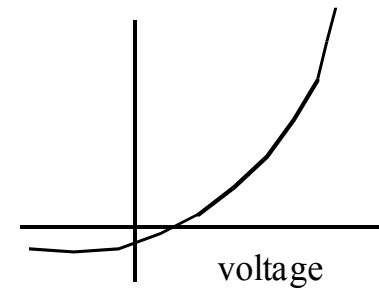

Diode
(i.e. PN diode, LED,
laser diode, photodiode)

$$i_D = I_S \left(e^{v_D/nV_T} - 1 \right)$$

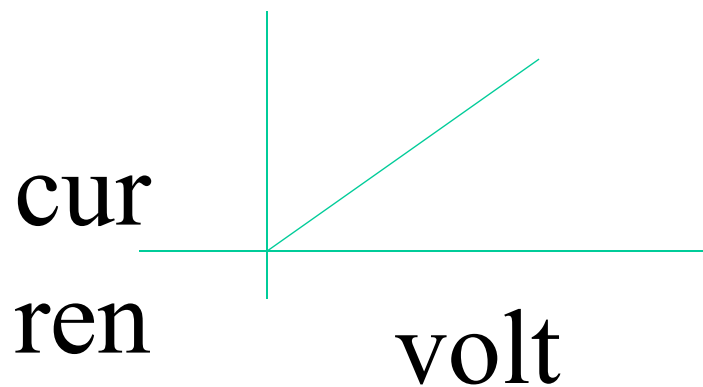

cur
ren

volt

Normal
Ohm's Law: $i =$
resistor

Introduction to Diodes

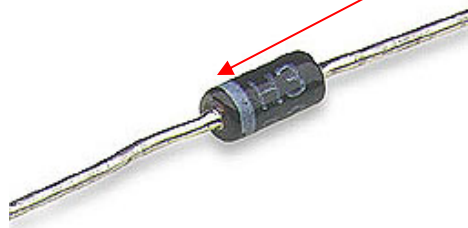
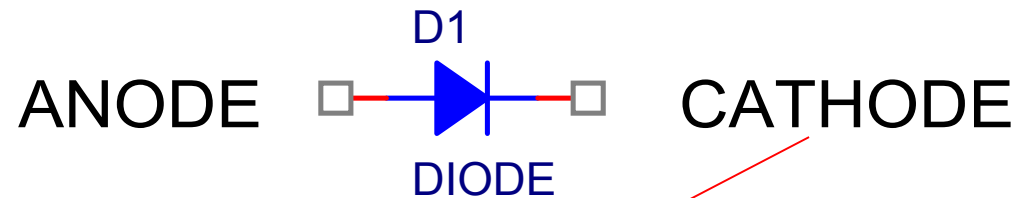

- A diode can be considered to be an electrical one-way valve.
- They are made from a large variety of materials including silicon, germanium, gallium arsenide, silicon carbide ...

Introduction to Diodes

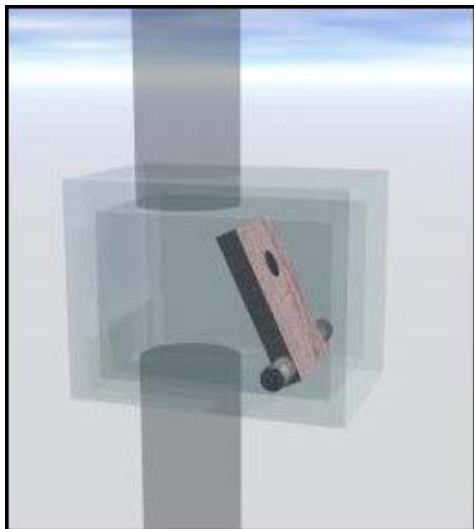

- In effect, diodes act like a flapper valve
 - Note: this is the simplest possible model of a diode

Introduction to Diodes

- For the flapper valve, a small positive pressure is required to open.
- Likewise, for a diode, a small positive voltage is required to turn it on. This voltage is like the voltage required to power some electrical device. It is used up turning the device on so the voltages at the two ends of the diode will differ.
 - The voltage required to turn on a diode is typically around 0.6 - 0.8 volt for a standard silicon diode and a few volts for a light emitting diode (LED)

Introduction to Diodes

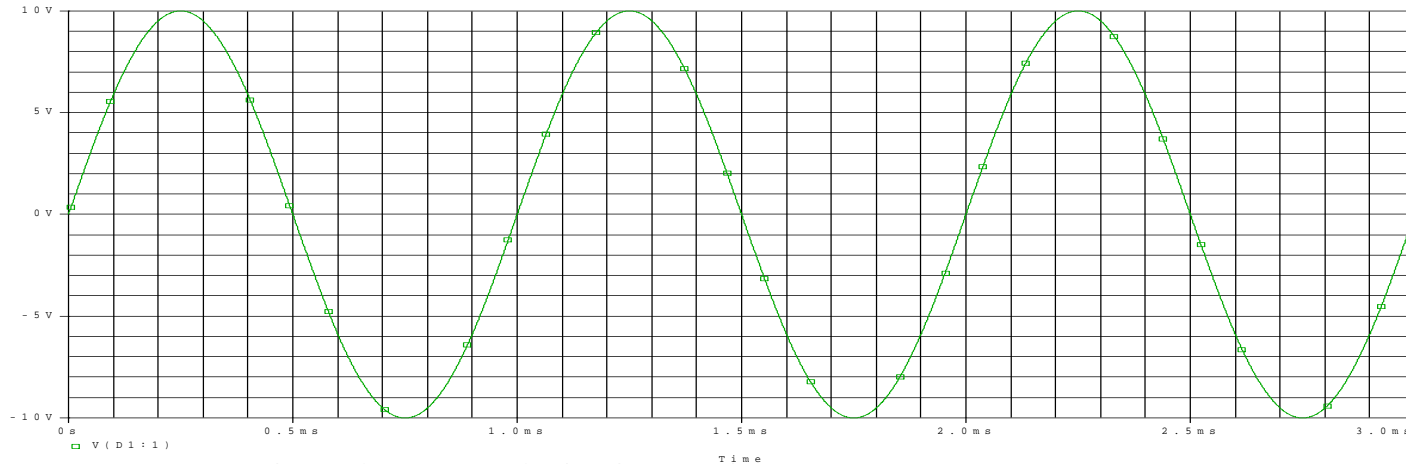

- 10 volt sinusoidal voltage source

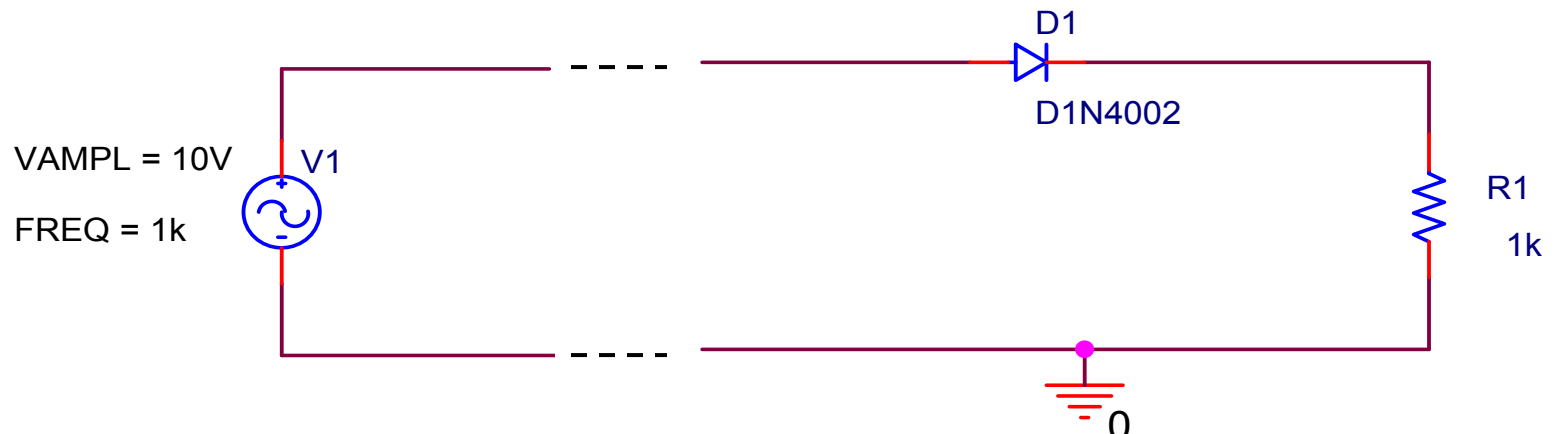

- Connect to a resistive load through a diode

Introduction to Diodes

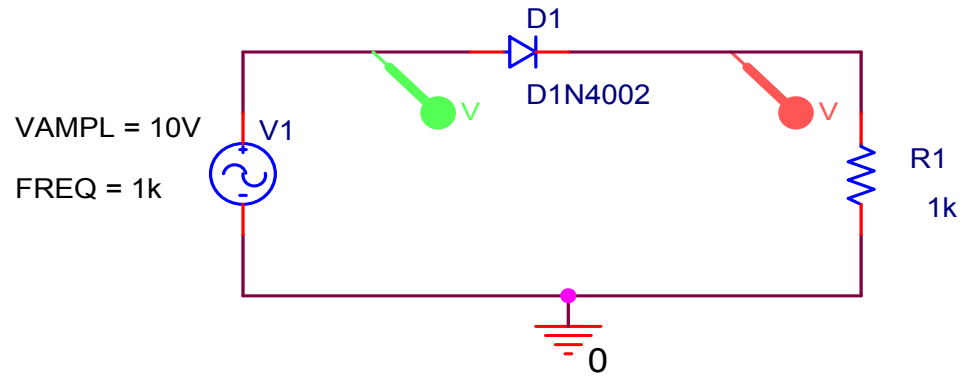

Only positive
current flows

0.
7
V

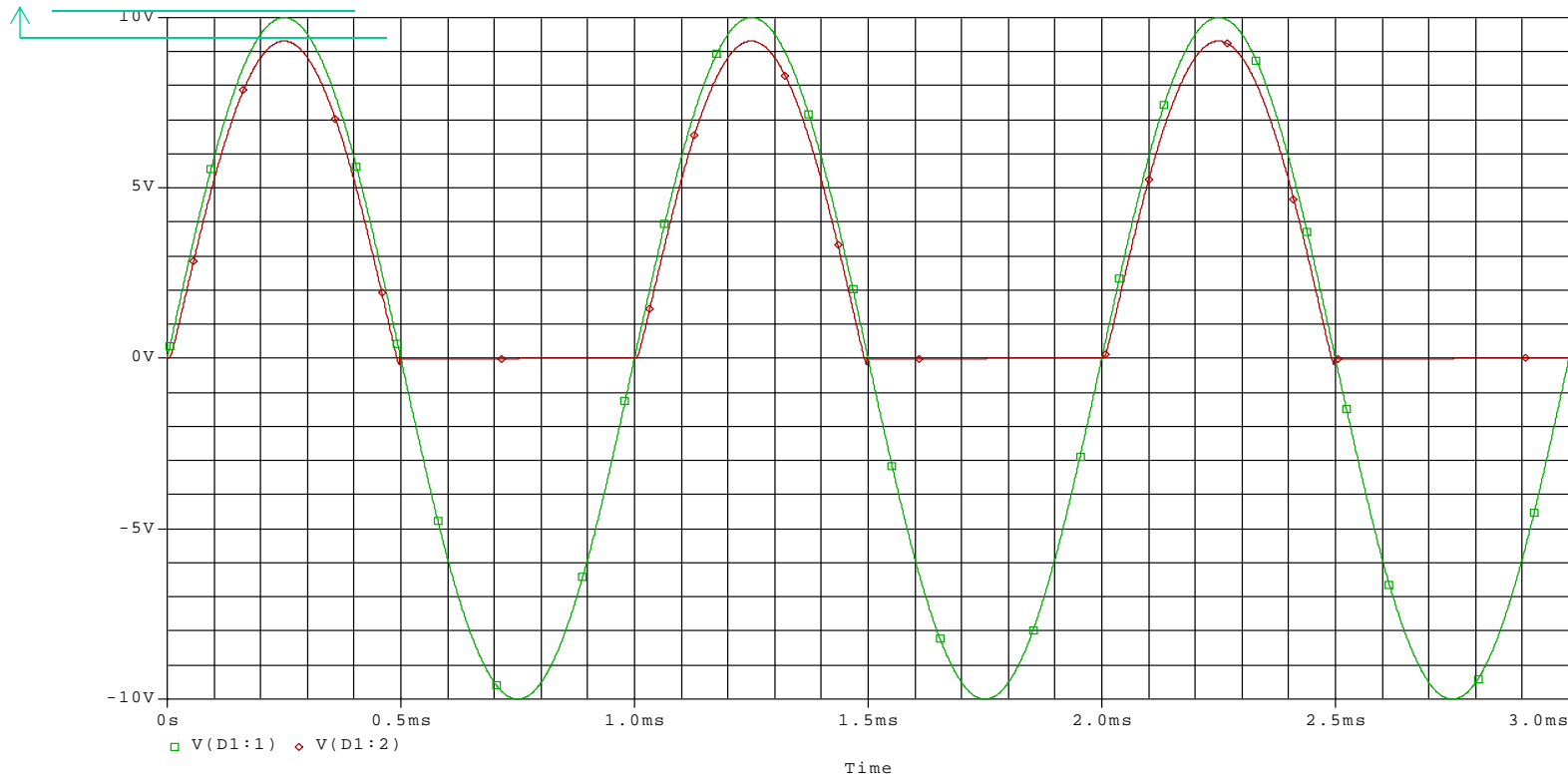



Semiconductor

Variable conductivity

A pure semiconductor is a **poor electrical conductor** as a consequence of having just the right number of electrons to completely fill its [valence bonds](#). Through various techniques (e.g., [doping](#) or [gating](#)), the semiconductor can be modified to have excess of electrons (becoming an ***n*-type semiconductor**) or a deficiency of electrons (becoming a ***p*-type semiconductor**). In both cases, the semiconductor becomes much more conductive (the conductivity can be increased by a factor of one million, or even more). Semiconductor devices exploit this effect to shape electrical current.

Junctions

When doped semiconductors are joined [to metals](#), [to different semiconductors](#), and [to the same semiconductor with different doping](#), the resulting junction often strips the electron excess or deficiency out from the semiconductor near the junction. This [depletion region](#) is [rectifying](#) (only allowing current to flow in one direction), and used to further shape electrical currents in semiconductor devices.

Energetic electrons travel far

Electrons can be excited across the energy [band gap](#) (see *Physics* below) of a semiconductor by various means. These electrons can carry their excess energy over distance scales of microns before dissipating their energy into heat, significantly longer than is possible in metals. This effect is essential to the operation of [bipolar junction transistors](#).

Light energy conversion

Electrons in a semiconductor can absorb light, and subsequently retain the energy from the light for a long enough time to be useful for producing electrical work instead of heat. This principle is used in the [photovoltaic cell](#). Conversely, in certain semiconductors, electrically excited electrons can relax by emitting light instead of producing heat. This is used in the [light emitting diode](#).

Thermal energy conversion

Semiconductors are good materials for [thermoelectric coolers](#) and [thermoelectric generators](#), which convert temperature differences into electrical power and vice versa. [Peltier coolers](#) use semiconductors for this reason.



P type and N type Materials

The semiconductor can be modified to have **excess of electrons** (becoming an **n-type semiconductor**) or a **deficiency of electrons** (becoming a **p-type semiconductor**).

In both cases, the semiconductor **becomes much more conductive** (the conductivity can be increased by a factor of one million, or even more). Semiconductor devices exploit this effect to shape electrical current.

Donor (n type semiconductors)

In semiconductor physics, a **donor** is a [dopant](#) atom that, when added to a [semiconductor](#), can form a [n-type](#) region. For example, when [silicon](#) (Si), having four [valence electrons](#), needs to be doped as an [n-type semiconductor](#), elements from [group V](#) like [phosphorus](#) (P) or [arsenic](#) (As) can be used because they have five valence electrons. A dopant with five valence electrons is also called a pentavalent impurity. Other pentavalent dopants are [antimony](#) (Sb) and [bismuth](#) (Bi). When substituting a Si atom in the [crystal lattice](#), four of the valence electrons of phosphorus form [covalent bonds](#) with the neighbouring Si atoms but the fifth one remains weakly bonded. At [room temperature](#), all the fifth electrons are liberated, can move around the Si crystal and can carry a current and thus act as [charge carriers](#). The initially neutral donor becomes positively charged (ionised).

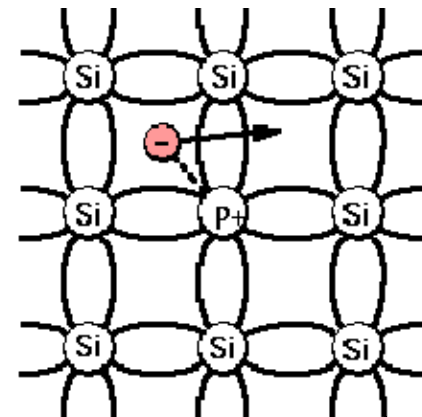

Acceptor (P type semiconductors)

In semiconductor physics, an **acceptor** is a dopant atom that when added to a semiconductor can form a p-type region. For example, when silicon (Si), having four valence electrons, needs to be doped as a p-type semiconductor, elements from group III like boron (B) or aluminium (Al), having three valence electrons, can be used. The latter elements are also called trivalent impurities. Other trivalent dopants include indium (In) and gallium (Ga).

When substituting a Si atom in the crystal lattice, the three valence electrons of boron form covalent bonds with three of the Si neighbours but the bond with the fourth neighbour remains unsatisfied. The unsatisfied bond attracts electrons from the neighbouring bonds. At room temperature, an electron from the neighbouring bond will jump to repair the unsatisfied bond thus leaving a hole (a place where an electron is deficient). The hole will again attract an electron from the neighbouring bond to repair this unsatisfied bond. This chain-like process results in the hole moving around the crystal and able to carry a current thus acting as a charge carrier. The initially electroneutral acceptor becomes negatively charged (ionised).

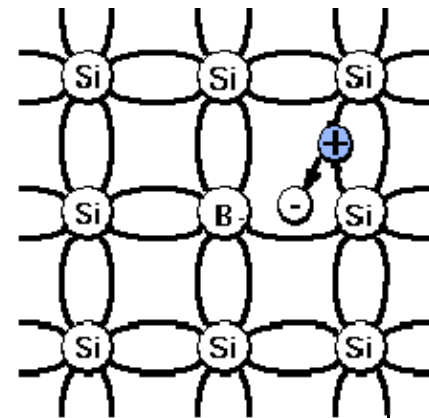

How Diodes Work

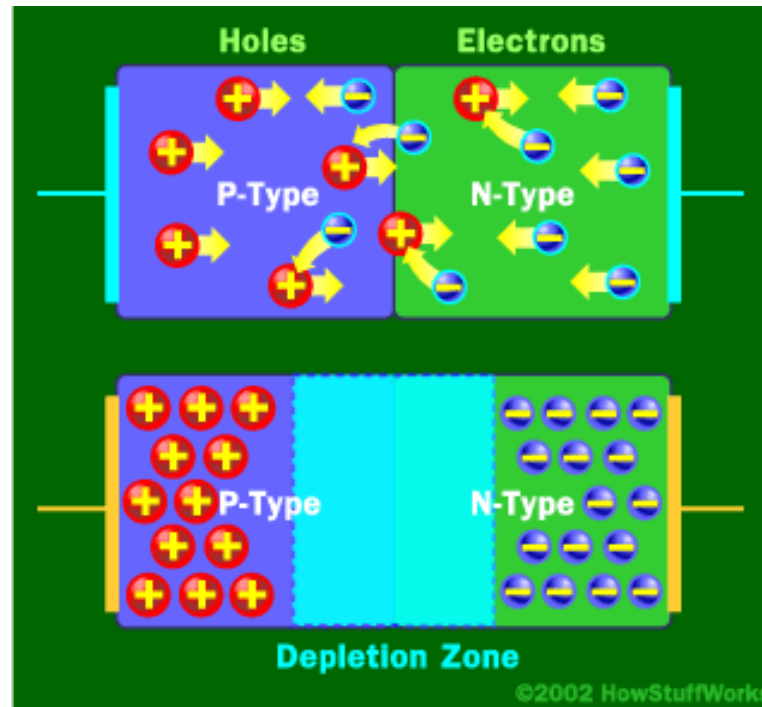

When put two materials together, free electrons from the N-type material fill holes from the P-type material. This creates an insulating layer in the middle of the diode called the depletion zone.

How Diodes Work

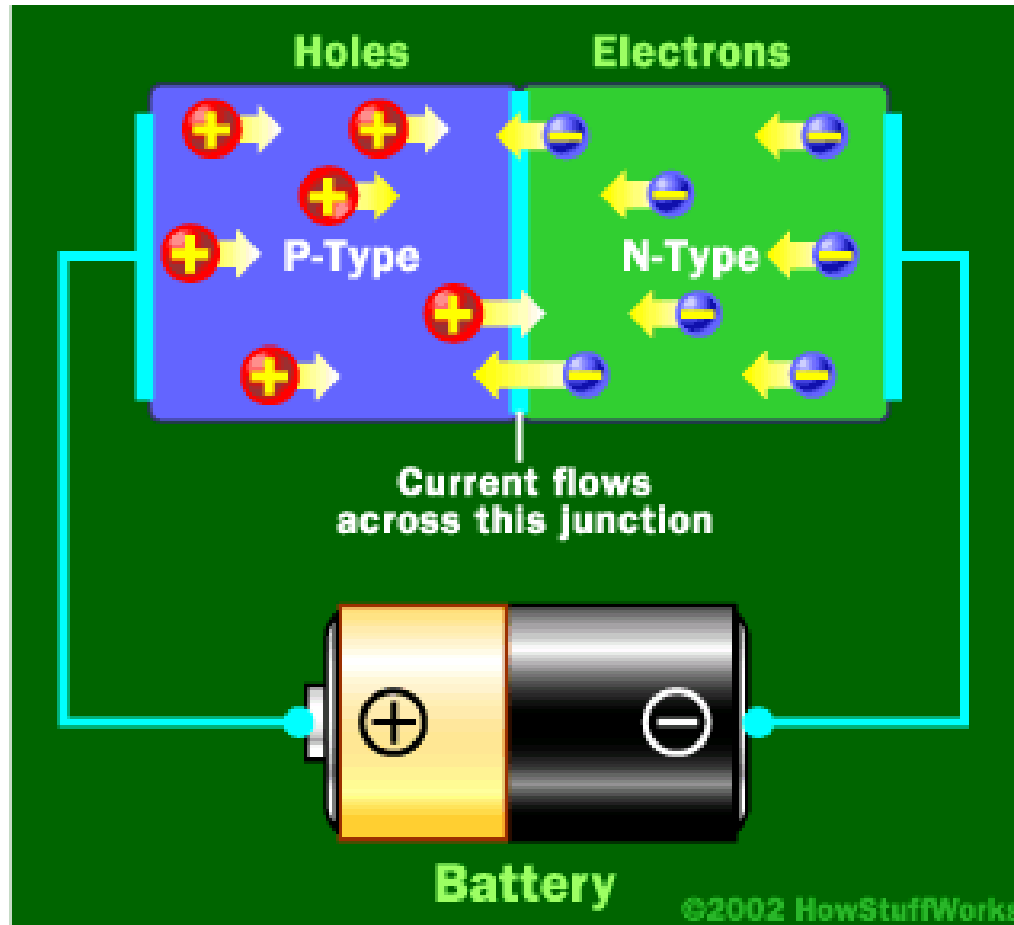
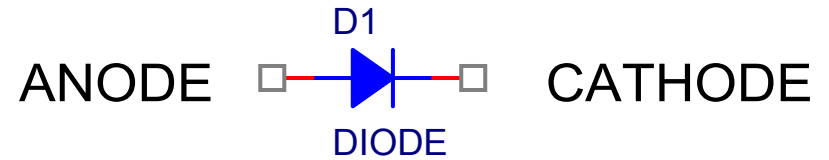

When the negative end of the circuit is hooked up to the N-type layer and the positive end is hooked up to P-type layer, electrons and holes start moving and the depletion zone disappears.

How Diodes Work

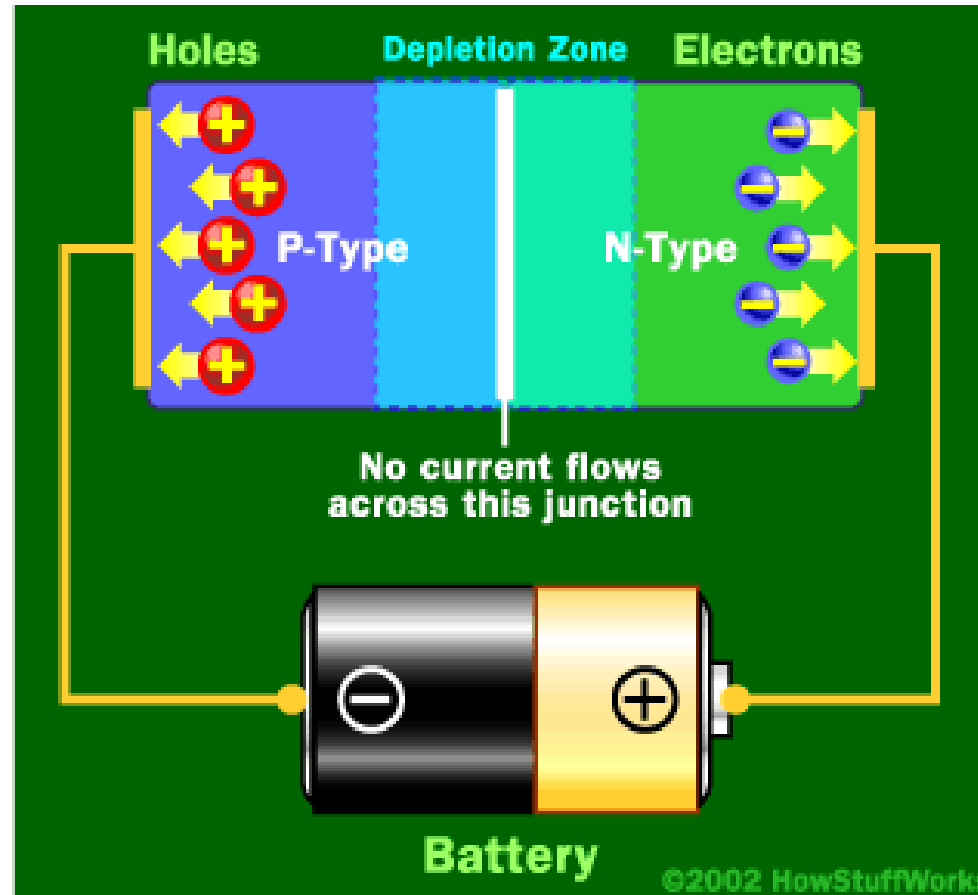
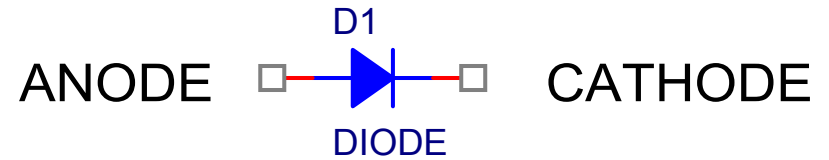

When the positive end of the battery is hooked up to the N-type layer and the negative end is hooked up to the P-type layer, free electrons collect on one end of the diode and holes collect on the other. The depletion zone gets bigger and **no current flows**.

Introduction to Diodes

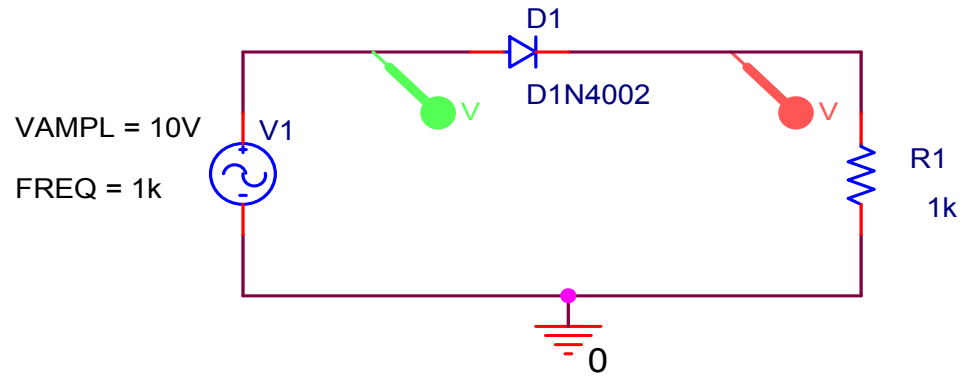

Only positive
current flows

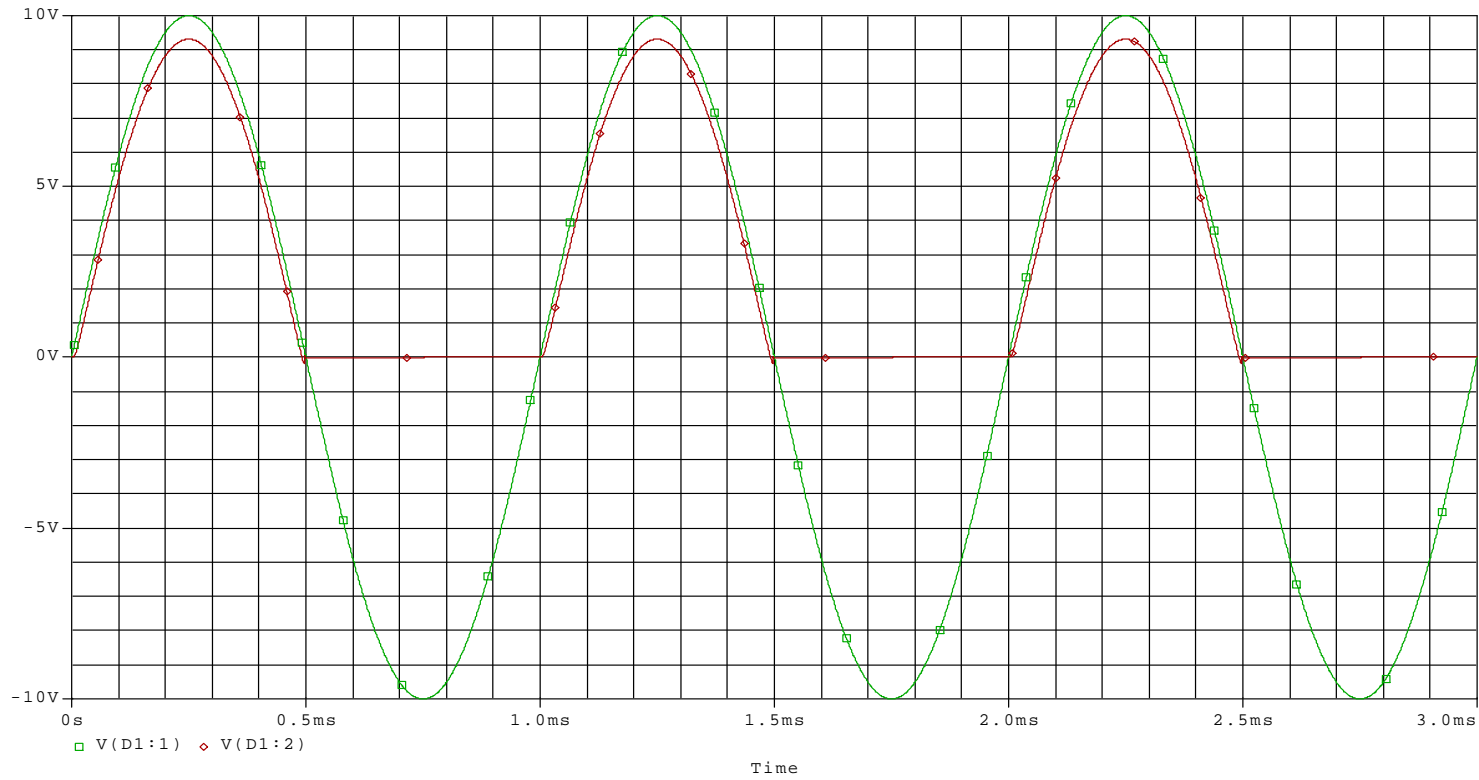

Part A: Diode i-v Characteristic Curves

- What is a i-v characteristic curve?
- i-v curve of an ideal diode
- i-v curve of a real diode

What is an i - v characteristic curve?

- Recall that the i - v relationship for a resistor is given by Ohm's Law: $i = v/R$
- If we plot the voltage across the resistor vs. the current through the resistor, we obtain

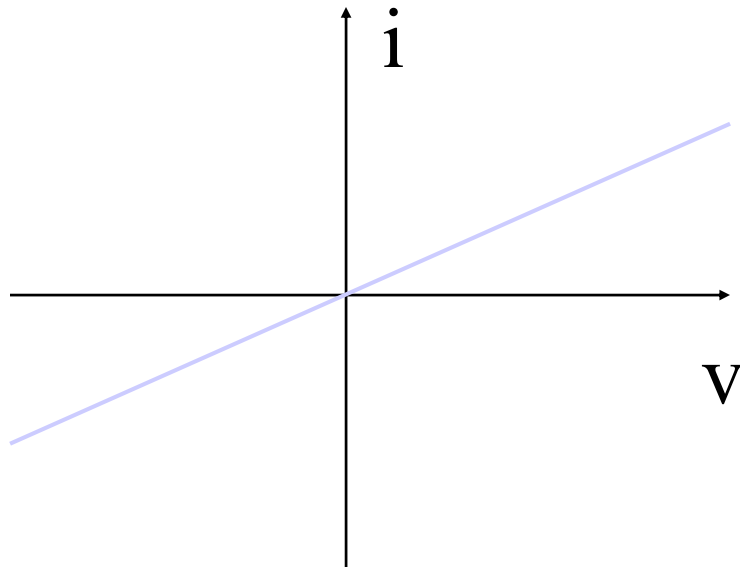

The slope of the straight line is given by $1/R$

What is an i - v characteristic curve?

If we change the axis variables, we can obtain i - v characteristic curves.

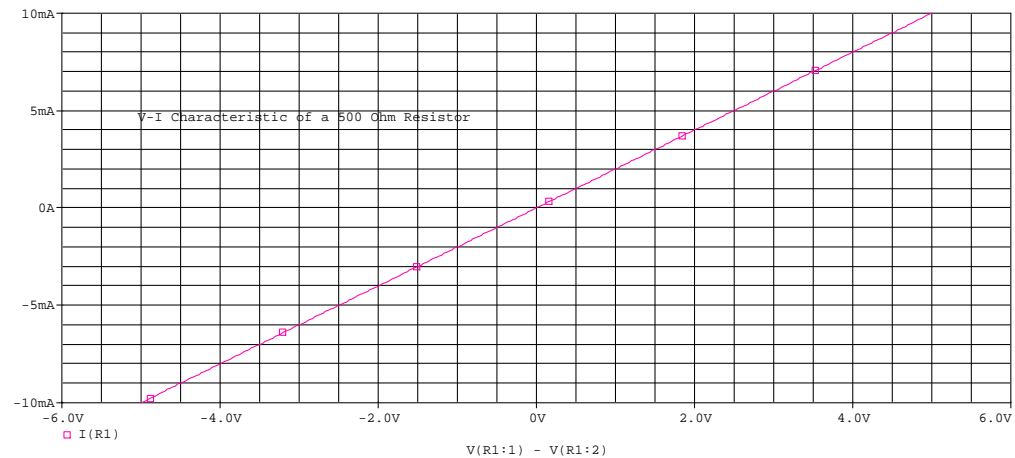
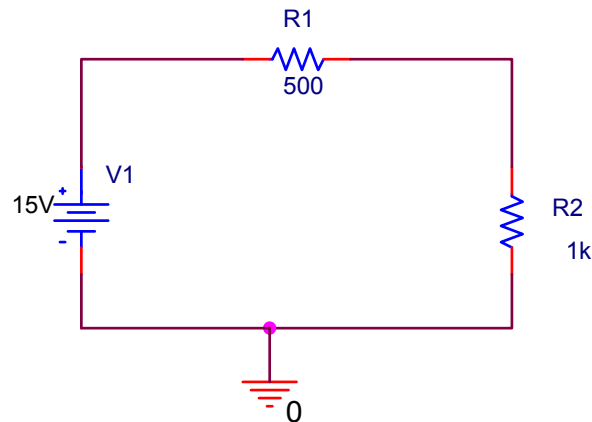

i-v characteristic for an ideal diode

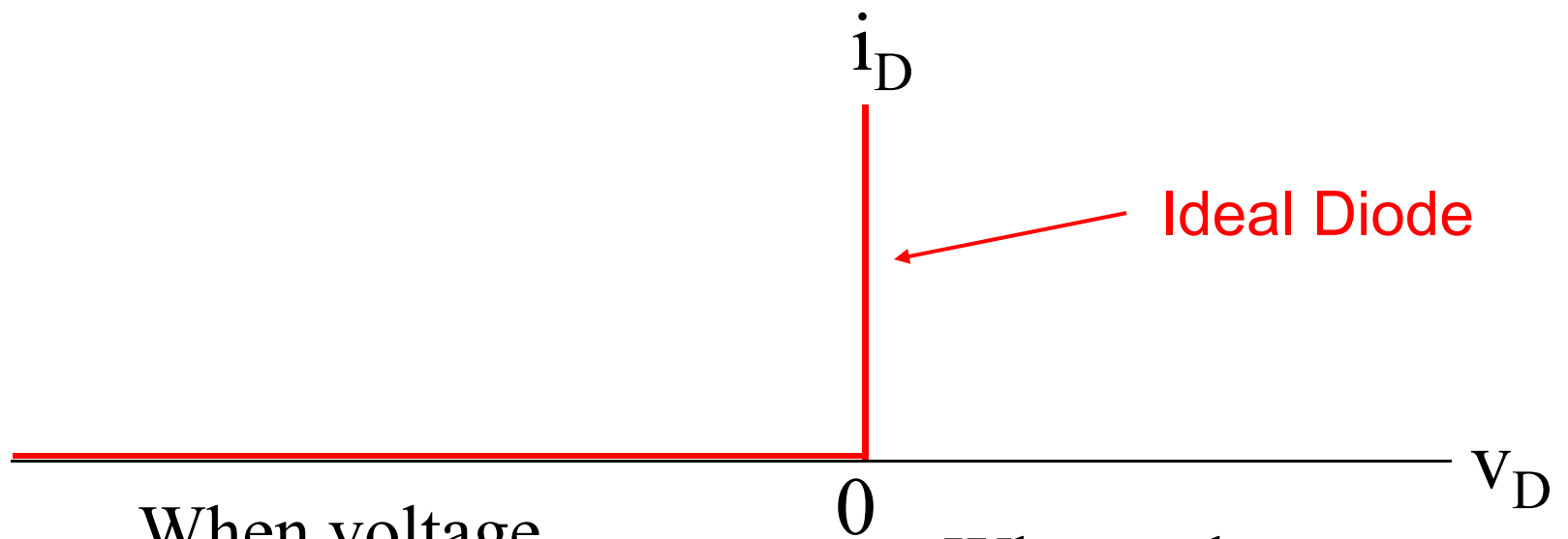

When voltage across the diode is negative, the diode looks like an open circuit.

When voltage across the diode is positive, the diode looks like a short.

i-v characteristic of a real diode

- Real diode is close to ideal

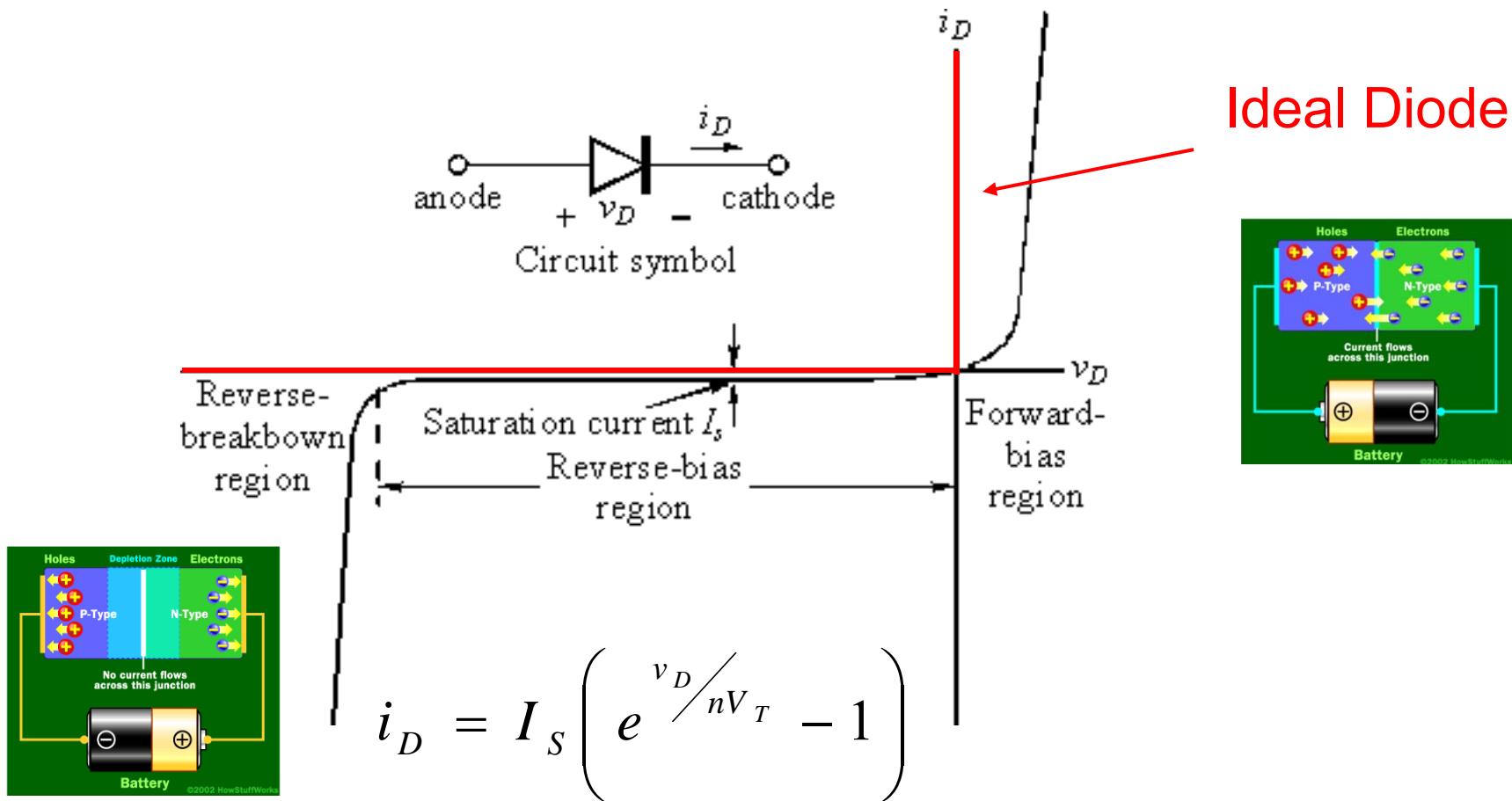

How Diodes Work

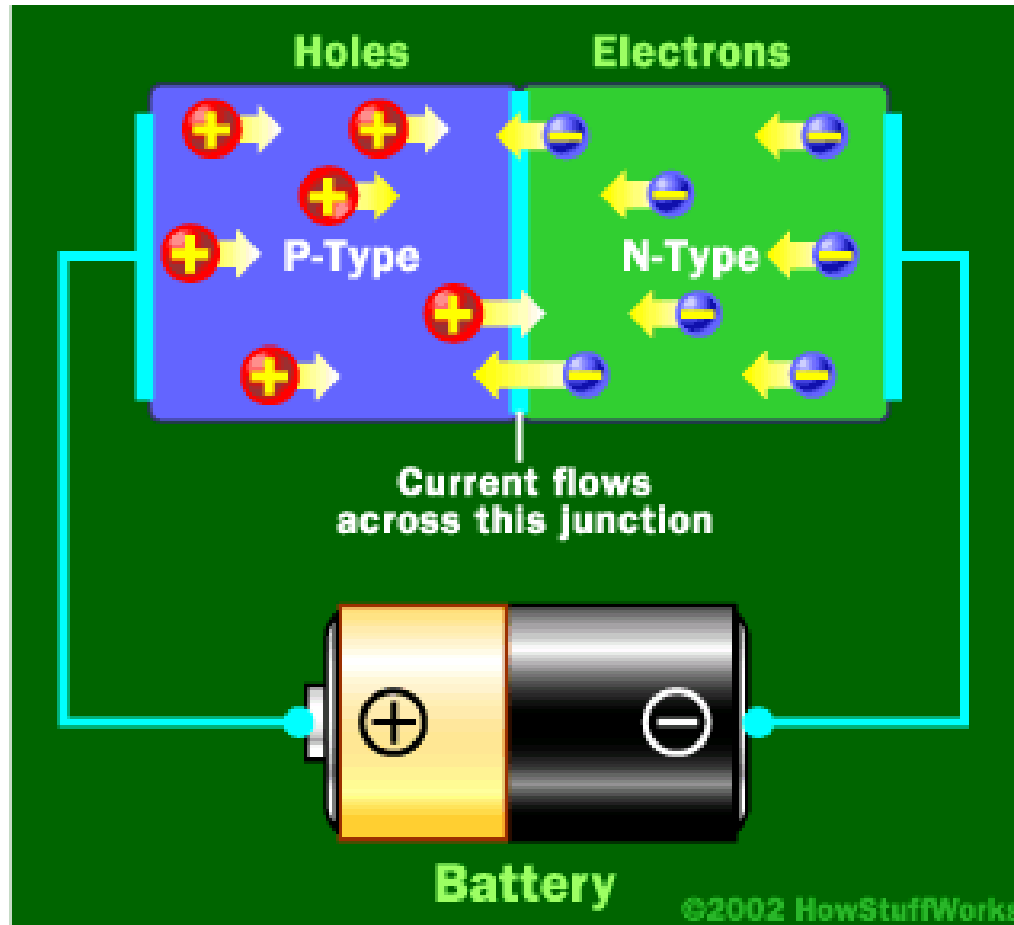
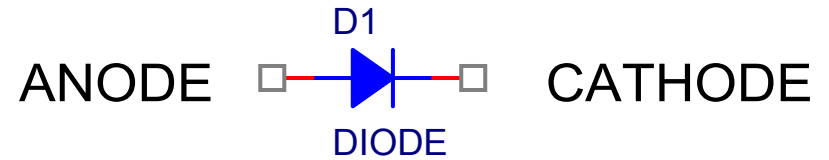

When the negative end of the circuit is hooked up to the N-type layer and the positive end is hooked up to P-type layer, electrons and holes start moving and the depletion zone disappears.

How Diodes Work

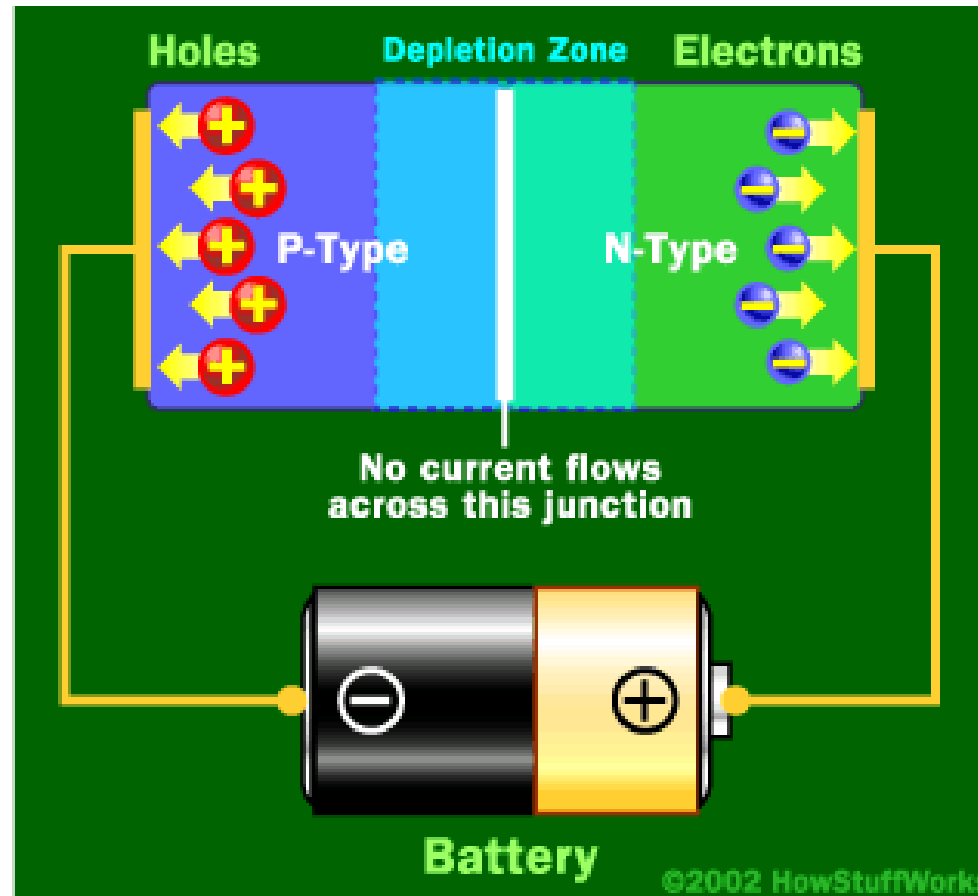
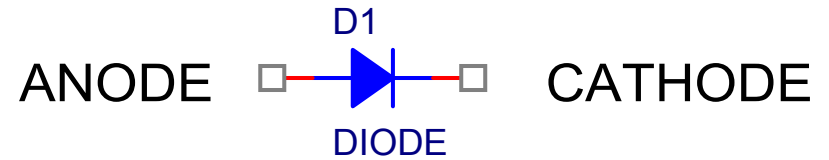

When the positive end of the battery is hooked up to the N-type layer and the negative end is hooked up to the P-type layer, free electrons collect on one end of the diode and holes collect on the other. The depletion zone gets bigger and no current flows.

Real diode characteristics

- A very large current can flow when the diode is forward biased. For power diodes, currents of a few amps can flow with bias voltages of 0.6 to 1.5V. Note that the textbook generally uses 0.6V as the standard value, but 0.7V is more typical for the devices.
- Reverse breakdown voltages can be as low as 50V and as large as 1000V.
- Reverse saturation currents I_s are typically 1nA or less.

The diode equation

- The i_D - v_D relationship (without breakdown) can be written simply as:

$$i_D = I_S \left(e^{v_D / nV_T} - 1 \right)$$

- v_D is the voltage across the diode and i_D is the current through the diode. n and I_S are constants. V_T is a voltage proportional to the temperature, we use 0.0259V.
- Note that for v_D less than zero, the exponential term vanishes and the current i_D is roughly equal to minus the saturation current.
- For v_D greater than zero, the current increases exponentially.

Diode equation

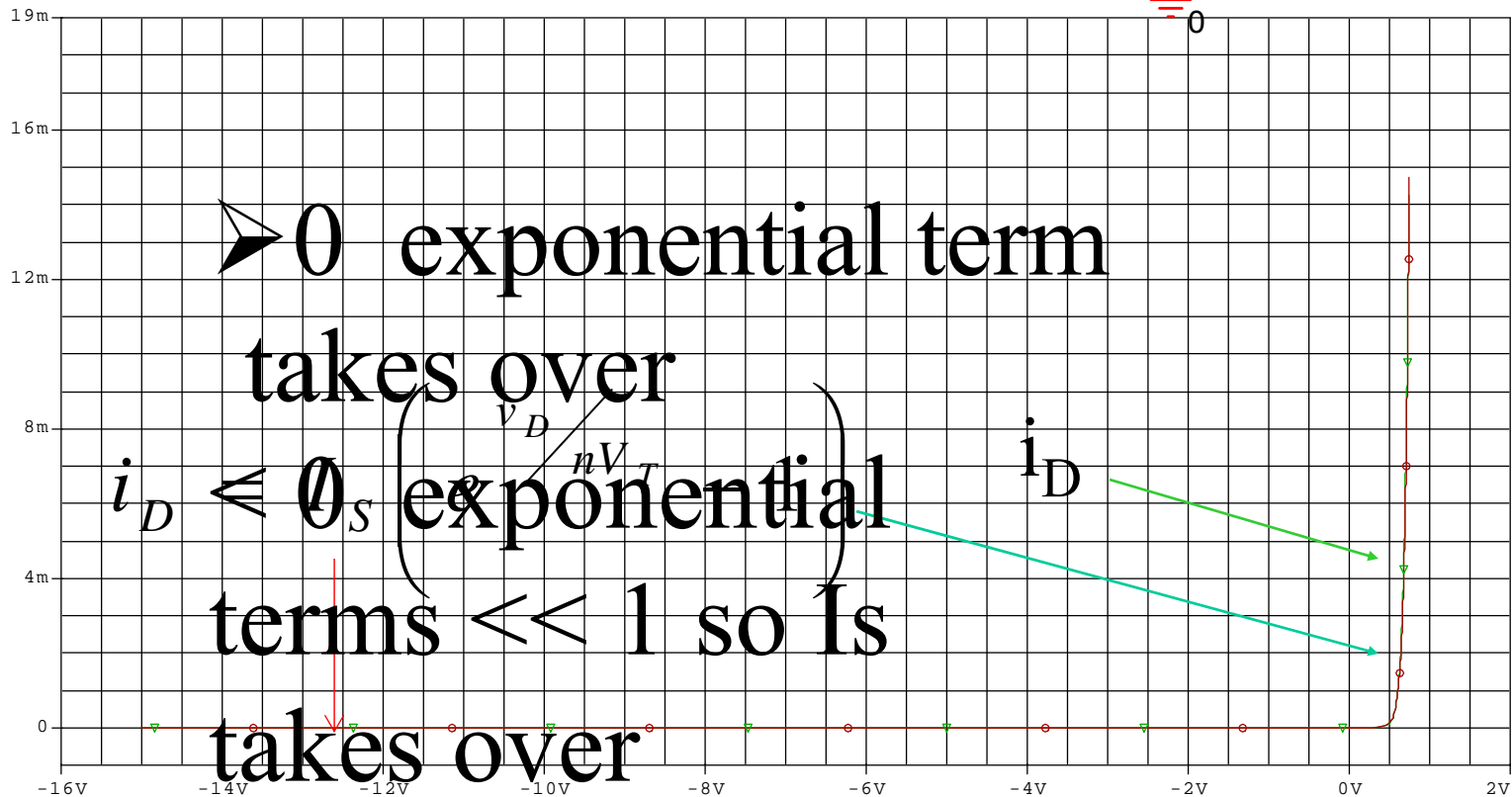
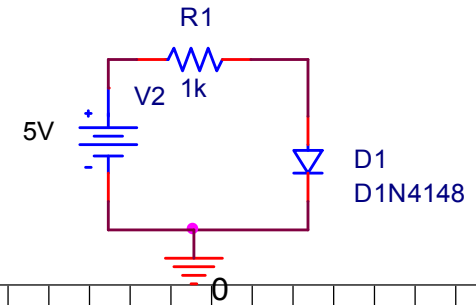

Both the simulated current vs. voltage (green) and the characteristic equation (red) for the diode are plotted.

Light Emitting Diodes

- The Light-Emitting Diode (LED) is a semiconductor pn junction diode that emits visible light or near-infrared radiation when **forward biased**.
- Visible LEDs emit relatively narrow bands of green, yellow, orange, or red light (**tens of nm**). Infrared LEDs emit in one of several bands just beyond red light.

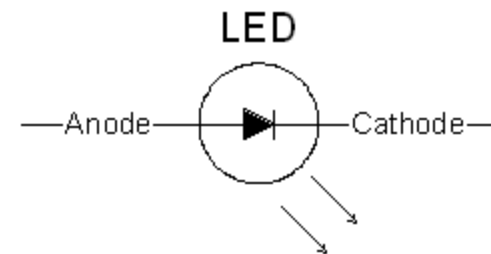
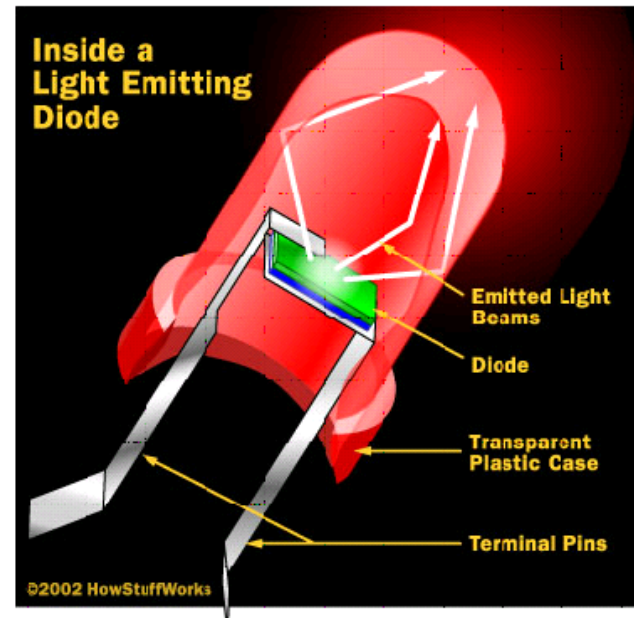

Facts about LEDs

- LEDs switch off and on rapidly, are very rugged and efficient, have a very long lifetime, and are easy to use ($\sim ns$ to μs).
- They are current-dependent sources, and their light output intensity is directly proportional to the forward current through the LED.
- Always operate an LED within its ratings to prevent irreversible damage.
- Use a series resistor (R_s) to limit the current through the LED to a safe value. V_{LED} is the LED voltage drop. It ranges from about **1.3V to about 3.6V**.
- I_{LED} is the specified forward current. (Generally 20mA).

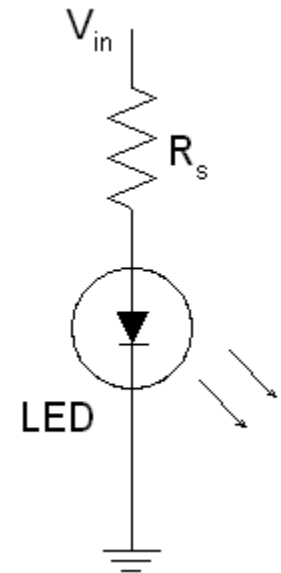

$$R_s = \frac{V_{in} - V_{LED}}{I_{LED}}$$

Approximate LED threshold voltages

Diode	V_{LED}		Diode	V_{LED}
infra-red	1.2		blue	3.6
red	2.2		purple	3.6
yellow	2.2		ultra-violet	3.7
green	3.5		white	3.6

How Light Emitting Diodes Work

by [Tom Harris](#)

[>>Tell a friend about this article!](#)

Rate This Article   [Printable Version](#)  [Reprints](#)

- > Introduction to How Light Emitting Diodes Work
- > [What is a Diode?](#)
- > [How Can a Diode Produce Light?](#)
- > [Lots More Information](#)
- > [What do you think?](#)

Light emitting diodes, commonly called LEDs, are real unsung heroes in the electronics world. They do dozens of different jobs and are found in all kinds of devices. Among other things, they form the numbers on [digital clocks](#), transmit information from [remote controls](#), light up watches and tell you when your appliances are turned on. Collected together, they can form images on a [jumbo television screen](#) or [illuminate a traffic light](#).

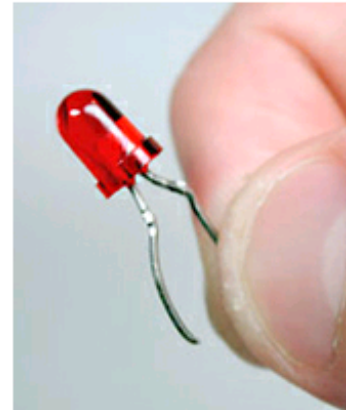

Basically, LEDs are just tiny light bulbs that fit easily into an electrical circuit. But unlike ordinary [incandescent bulbs](#), they don't have a filament that will burn out, and they don't get especially hot. They are illuminated solely by the movement of electrons in a [semiconductor](#) material, and they last just as long as a standard transistor.

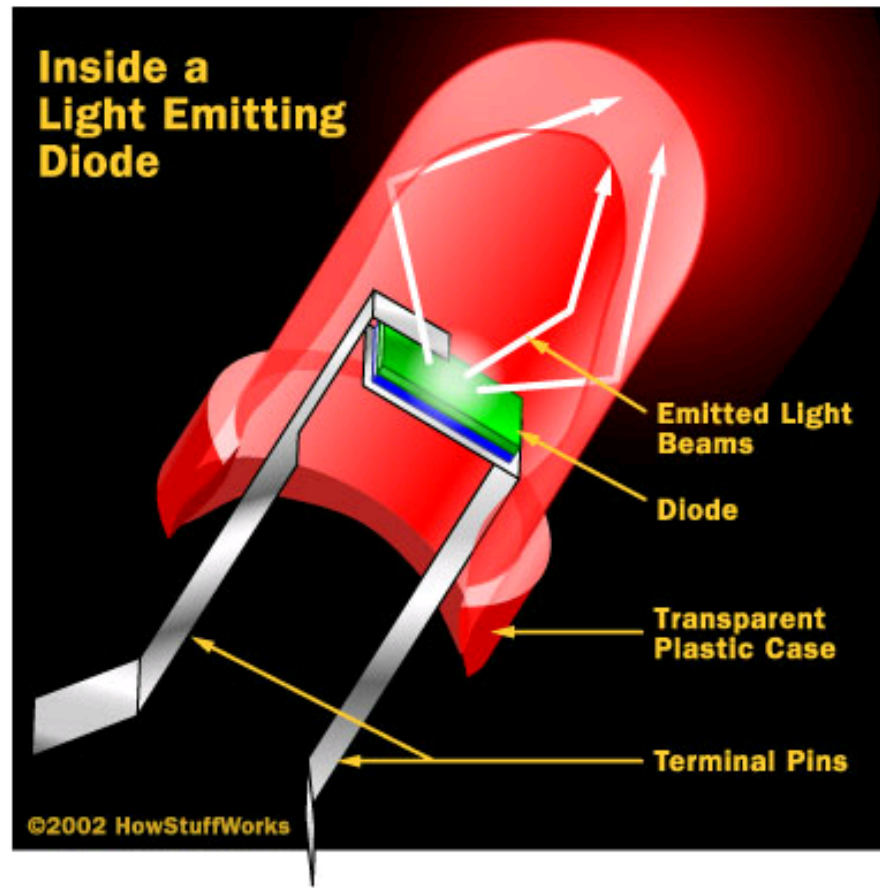

LEDs have several advantages over conventional incandescent lamps. For one thing, they don't have a filament that will burn out, so they last much longer. Additionally, their small plastic bulb makes them a lot more durable. They also fit more easily into modern electronic circuits.

Light Emitting Diode (LED)

The electroluminescent process of LED is to convert input electrical energy into output optical radiation in the visible or infrared (heat) portion of the spectrum, depending on the semiconductor material.

LEDs and laser diodes are very similar devices. In fact, when operating below their threshold current, all laser diodes act as LEDs.

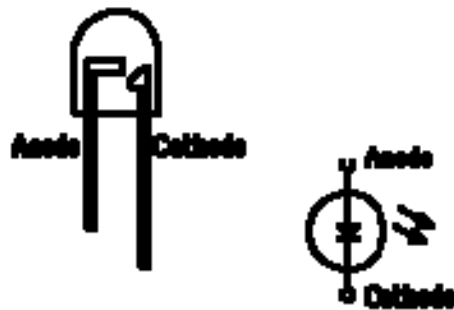

Flat side and long lead indicate cathode.

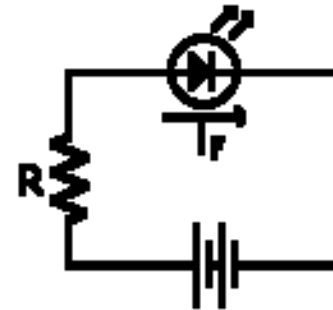

Energy levels

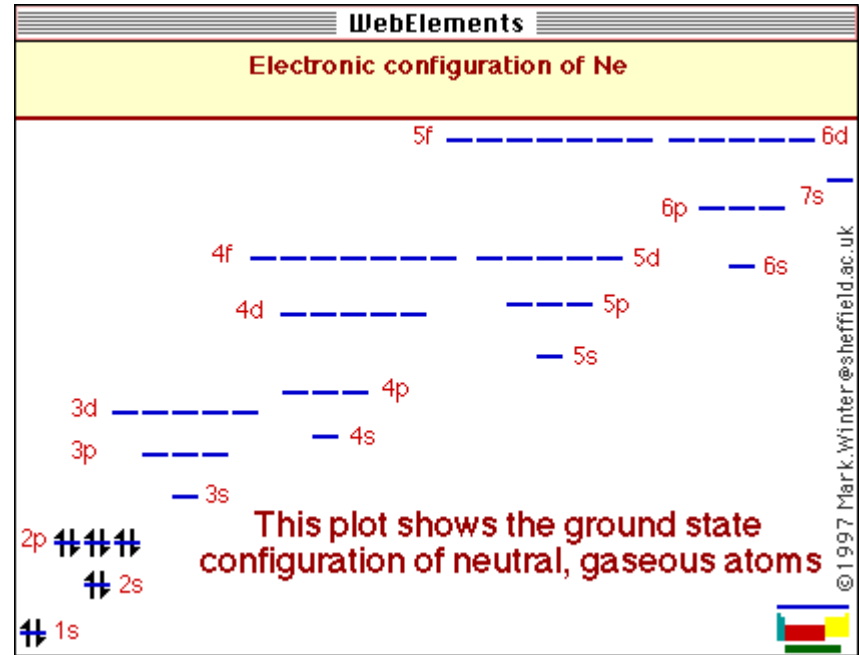
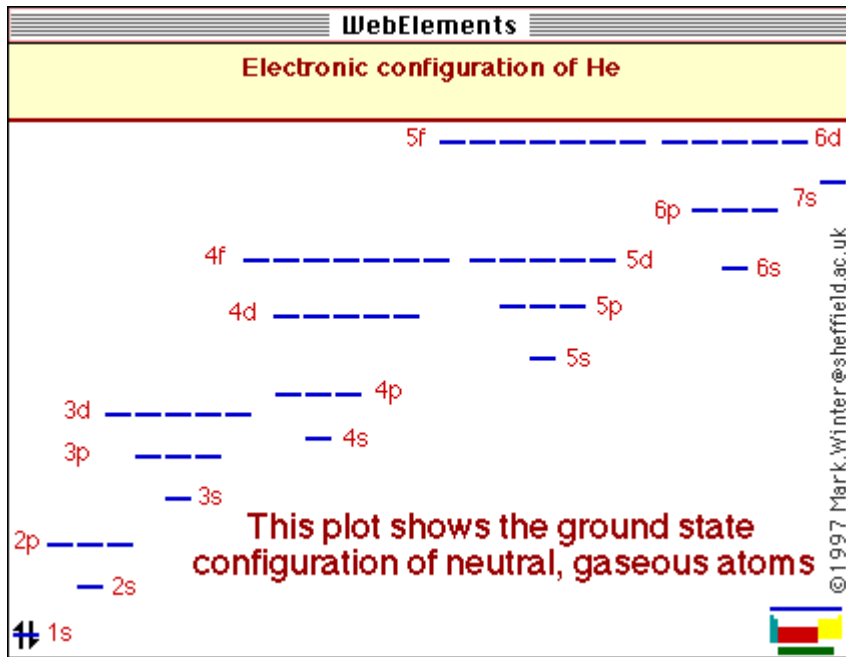

Helium (He) with its two electrons, has filled its s-

Forward Bias

- Forward bias is a voltage applied to the pn junction that REDUCES the electric field at the barrier, Reverse bias INCREASES the electric field at the junction
- When bias is applied the balance between drift and diffusion current is destroyed – net current flow
- In forward bias, drift current decreases very slightly (can assume it stays the same) but diffusion current increases – Net current flow
- In reverse bias opposite occurs with diffusion current decreasing and drift remaining same – Net current flow (this one is very small)

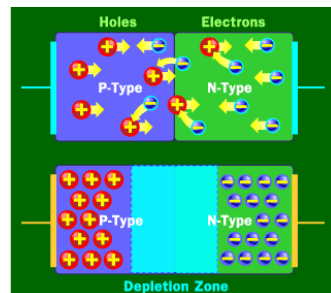
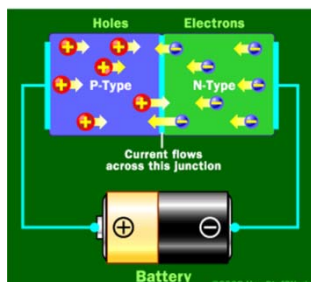
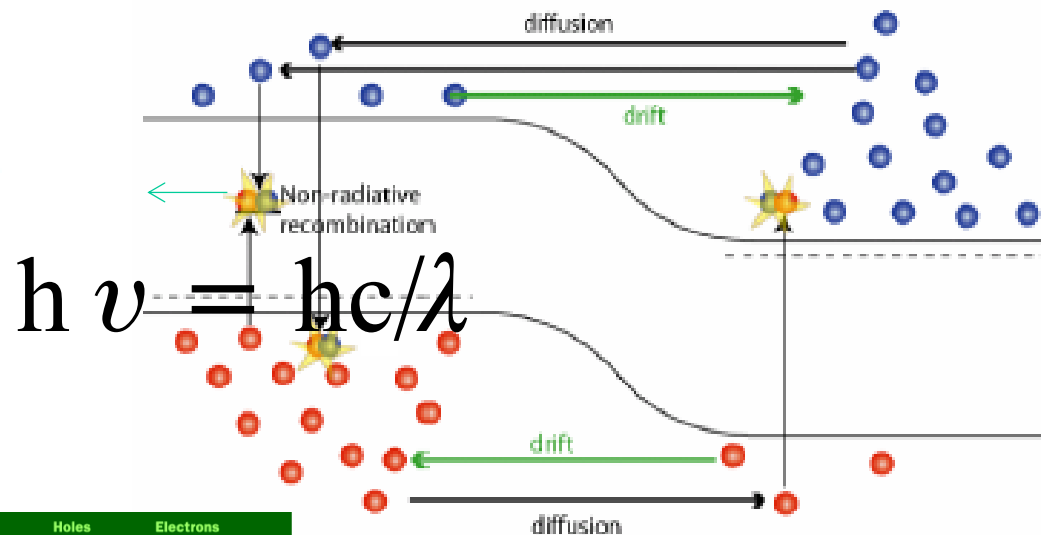

The energy conversion takes place in two stages: first, the energy of carriers in the semiconductor is raised above their equilibrium value by electrical input energy, and second, most of these carriers, after having lived a mean lifetime in the higher energy state, give up their energy as spontaneous emission of photons with energy nearly equal to the

The typical spectral output of a LED might look like:

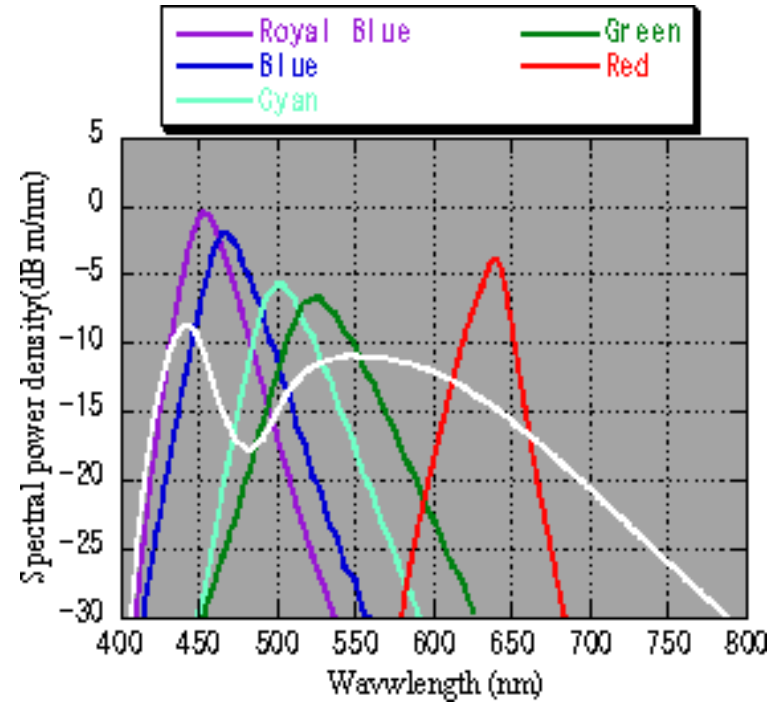

Spectra of different color LEDs

where k =Boltzman's constant= $8.62e-5$ eV/°K, T = temperature (°K) and q = single electron charge = $1.6e-19$ coulombs and I_{d0} a function of energy gap. The latter term means that different

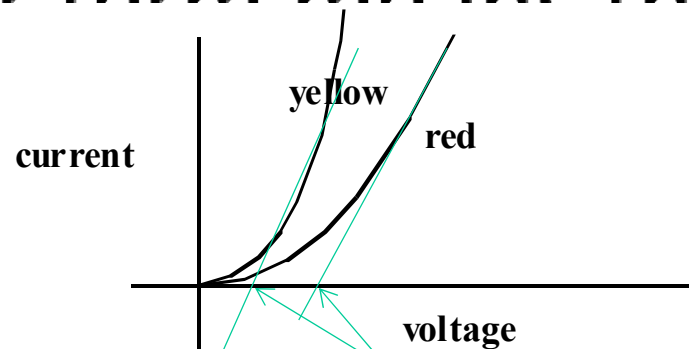

V_{thres}
hold

Approximate LED threshold voltages

Diode	V_{LED}		Diode	V_{LED}
infra-red	1.2		blue	3.6
red	2.2		purple	3.6
yellow	2.2		ultra-violet	3.7
green	3.5		white	3.6

The output power vs. forward current for the LED appears as a linear function. The relation is given as

$$\text{output power} = \eta_o I_{inj} \frac{h\nu}{q}$$

Where η_o is overall device efficiency=extraction efficient x the radiative efficiency x injection efficiency, h is plank constant and ν is frequency of emitting light, q = single electron charge and $I_{inj} = I_d$. All but $I_{inj} = I_d$ are constant. This linear relation should be verified with your experiment

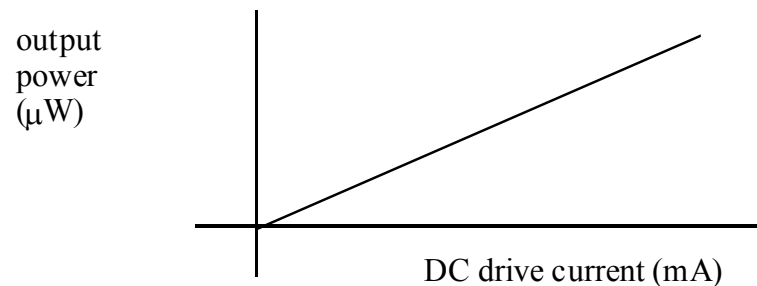

The output power vs. forward current for the LED

LED

There are two basic types of LED structures: edge emitters and surface emitters.

$$P = P_0 \cos\theta$$

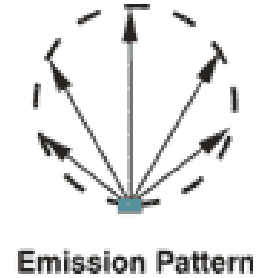
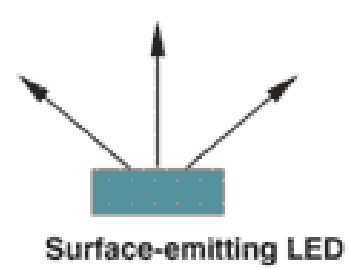
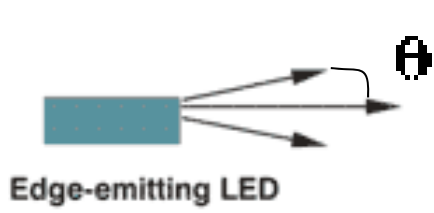

output power is high (emitting spot is very small, typically 30-50 μm)

narrow emission spectra (FWHM is typically about 7% of the central wavelength)

Narrow beam pattern

w.wang

simple structure, are relatively inexpensive, offer low-to-moderate output power levels, and are capable of low-to-moderate operating speeds

output power is as high or higher than the edge-emitting LED, but the emitting area is large, causing poor coupling efficiency to the optical fiber

emit light in all directions

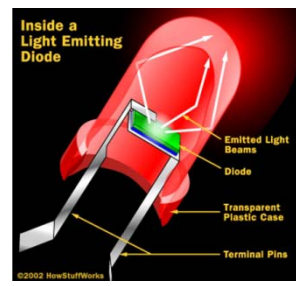

Using the setup as shown in Figure., where the current is provided by the voltage source V is limited by the

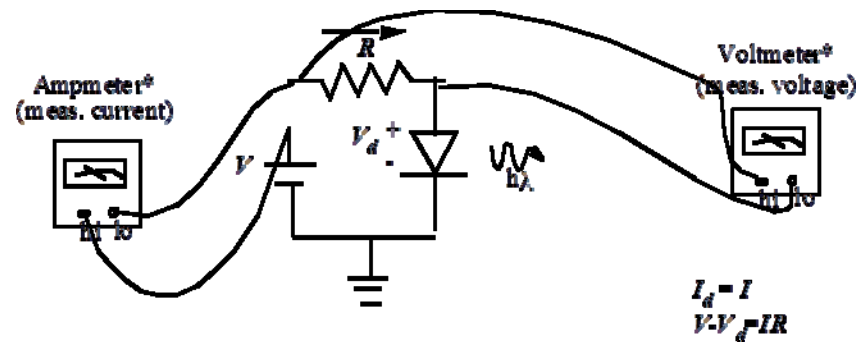

Coherence

For longitudinal or temporal coherence, the coherence length ℓ_c is related to the wavelength λ and the total frequency bandwidth of the laser $\Delta\lambda$ by

$$\ell_c = \frac{\lambda^2}{\Delta\lambda}$$

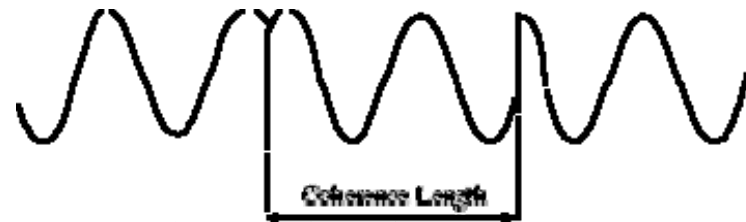

Note: $\Delta\lambda$ is the actual bandwidth of the laser beam given in wavelength units.

For transverse or spatial coherence, the transverse coherence length ℓ_t is related to the laser wavelength λ , the laser source diameter at its origin s , and the distance r the beam has propagated from its origin, by the following relationship.

$$\ell_t = \frac{r\lambda}{s}$$

LASER

LASAER = light amplification by stimulated emission of radiation

Invented dated to 1958 with the publication of the scientific paper, Infrared and Optical Masers, by Arthur L. Schawlow, then a Bell Labs researcher, and Charles H. Townes, a consultant to Bell Labs

Property of Laser Light

- **Nearly** monochromatic: consists of an extremely narrow range of wavelengths
- **Highly** Directional: travel in a single direction within a narrow cone of divergence
- **Highly** Coherence: coherence is the most fundamental property of laser light and distinguishes it from the light from other sources

Laser gain medium

Atoms such as in the red helium-neon (HeNe) laser, the visible and ultraviolet argon ion and helium-cadmium (HeCd) lasers, and the green and yellow copper vapor lasers (CVL)

Molecules such as in the infrared carbon dioxide (CO₂) laser, the ultraviolet excimer lasers such as ArF and KrF, and the pulsed N₂ laser

Liquids such as those involving various organic dye molecules dilute dissolved in various solvent solutions

Dielectric solids such as those involving neodymium atoms doped in YAG or glass to make the crystalline Nd:YAG or Nd:glass lasers

Semiconductor materials such as gallium arsenide or indium phosphide crystals or various mixtures of impurities blended with those and other semiconductor species

Examples of Current Laser system

Type of Laser	$\lambda_{21}(\text{nm})$	$\Delta\lambda_{21}(\text{Hz})$	$\sigma_{21}(\text{cm}^2)$	$\Delta N_{21}(\text{cm}^{-3})$	$g_{21}(\text{cm}^{-1})$	$I_{\text{sat}}(\text{W}/\text{cm}^2)$
HeNe	632.8	2×10^9	3×10^{-13}	7×10^9	2×10^{-3}	6.2
Argon	488.0	2×10^9	2.5×10^{-12}	1×10^{15}	5×10^{-3}	16.3
HeCd	441.6	2×10^9	9×10^{-14}	4×10^{12}	3×10^{-3}	7.1
Copper Vapor	510.5	2×10^9	8×10^{-14}	6×10^{13}	5×10^{-2}	9.0
CO ₂	10,600	6×10^7	3×10^{-18}	5×10^{15}	8×10^{-3}	1.6×10^{-2}
Excimer	248.0	1×10^{13}	2.6×10^{-16}	1×10^{16}	2.6×10^{-2}	3.4×10^5
Dye (Rh6-G)	577	5×10^{13}	2×10^{-16}	2×10^{18}	2.4	3.4×10^9
Ruby	694.3	3×10^{11}	2.5×10^{-20}	4×10^{19}	1.0	3.8×10^7
Nd:YAG	1064.1	1.2×10^{11}	6.5×10^{-19}	3×10^{19}	2.0	1.2×10^7
Ti:Al ₂ O ₃	760	1.5×10^{14}	3.4×10^{-19}	3×10^{18}	1.0	2.0×10^9
Semiconductor	800	1×10^{14}	1×10^{-15}	1×10^{18}	10^3	2.5×10^9

Requirements for a laser

There are three types of processes involving the interaction of light beams with atoms that have electrons residing in various energy levels:

SPONTANEOUS EMISSION

ABSORPTION

STIMULATED EMISSION

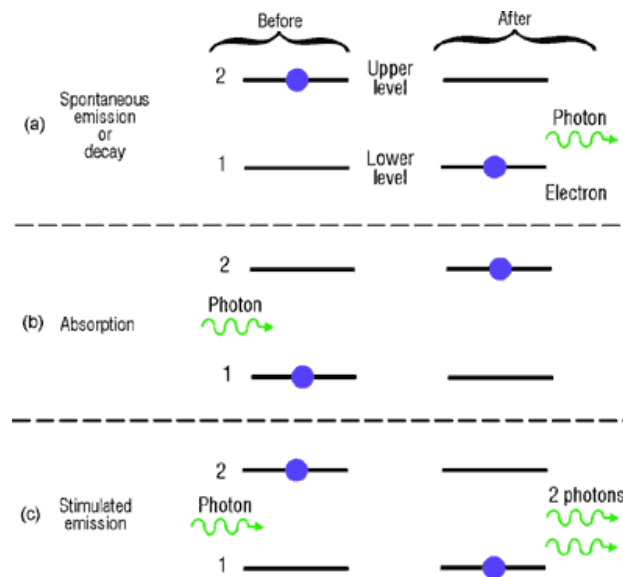

SPONTANEOUS EMISSION

An atom in an excited state is unstable and will release spontaneously its excess energy and return to the ground state. This energy release may occur in a single transition or in a series of transitions that involve intermediate energy levels. For example, an atom in state E_3 could reach the ground state by means of a single transition from E_3 to E_1 , or by two transitions, first from E_3 to E_2 and then from E_2 to E_1 . In any downward atomic transition, an amount of energy equal to the difference in energy content of the two levels must be released by the atom.

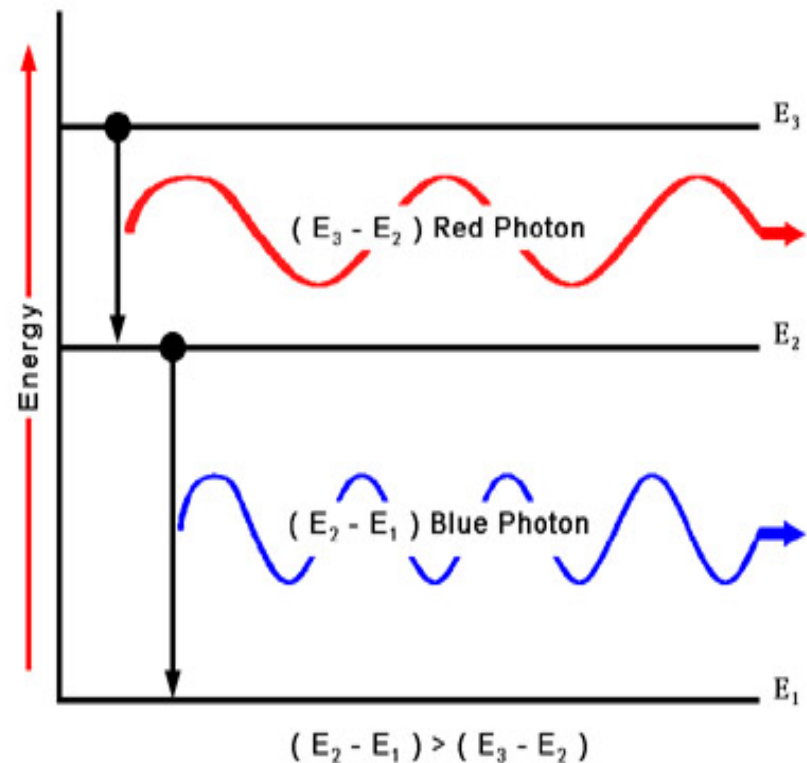

A. Guenther UCONN

Most excited energy levels undergo spontaneous emission. Each level has a specific lifetime τ over which it will remain in that level before decaying to a lower-lying level. That lifetime is determined by the interactions of the electron with the other electrons and nuclei of that atom. Typical lifetimes of electrons residing in specific levels that decay by radiating in the visible portion of the spectrum are of the order of 10–100 nsec. The photon radiated during spontaneous emission has the exact wavelength λ_{21} and frequency ν_{21} corresponding to the difference in energy ΔE_{21} of the two involved energy levels (1 and 2 in this case) according to the relationship

$$\Delta E_{21} = h\nu_{21} = \frac{hc}{\lambda_{21}}$$

in which h is Planck's constant such that $h = 6.63 \times 10^{-34}$ joule-sec and c is the speed of light, $c = 3 \times 10^8$ m/sec.

Because different materials have different energy-level arrangements, they radiate at different wavelengths and thus emit different colors or frequencies of light that are specific to the material.

ABSORPTION

When a large group of atoms is assembled and irradiated with light, most of those atoms are in the ground-state energy level. If the photons of the impinging light have the appropriate energy ΔE_{20} for example, the light will be absorbed according to the following expression for the variation of intensity I with the distance L into the material (known as **Lambert Law**):

$$I = I_0 e^{-\sigma_{20} N_0 L}$$

Where I_0 = intensity of the beam when it first reaches the atoms

σ_{20} = cross section for absorption or emission of those two levels (cm^2),

N_0 = population density of atoms residing in level 0 (atoms/cm^3),

$\sigma_{20} N_0$ = absorption coefficient

w.wang

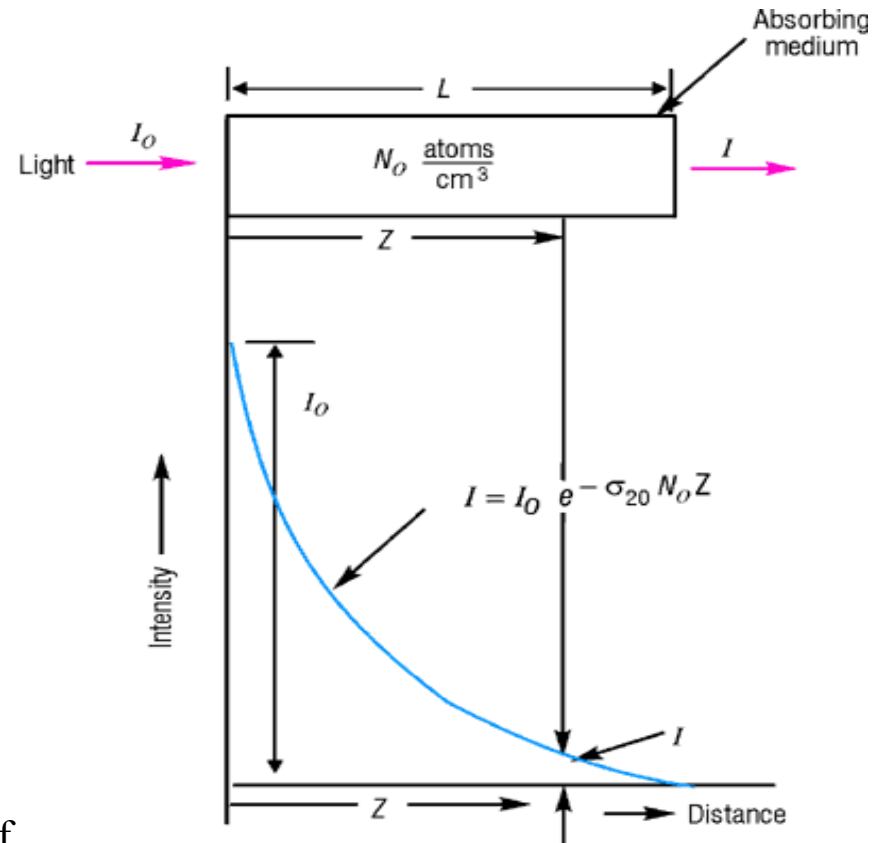

A. Guenther UCONN

Intensity variation versus depth z into an absorbing sample

Stimulated Emission

The third process, shown in Figure c is referred to as *stimulated emission*. It results when an electron is in a higher-lying level, such as level 2, and a photon of light of wavelength λ_{21} collides with the atom. During the collision the photon stimulates the atom to radiate a second photon having exactly the same energy ΔE_{21} as that of the incident photon and traveling in exactly the same direction in order to satisfy the laws of conservation of energy and momentum. Hence, one photon leads to two identical photons, which, in effect, leads to an amplification process. A photon has been gained at the expense of the loss of energy stored within the atom.

w.wang

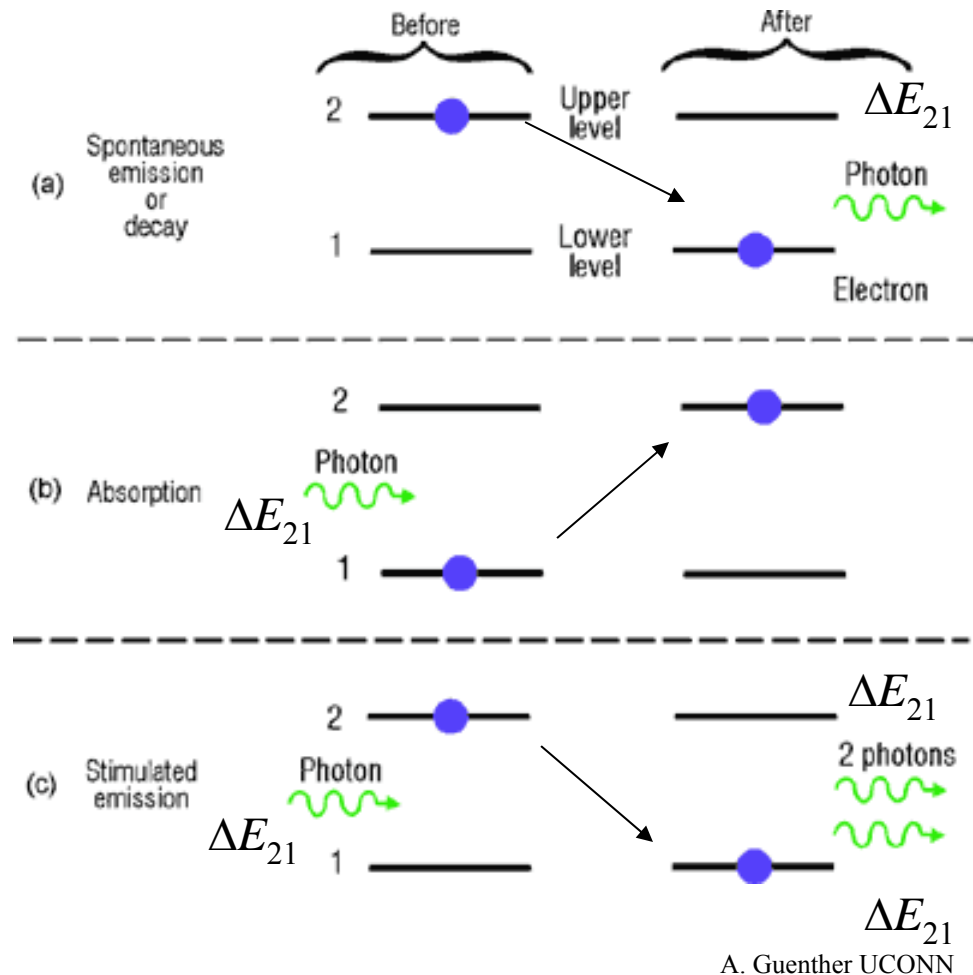

A. Guenther UCONN

Stimulated Emission

Suppose that we were able to “pump” (excite) a significant amount of population of the medium from level 0 to level 2. Also, for the time being let us assume that there is no population in level 1. (This is an unlikely scenario but we will do this as a “thought” experiment for illustrative purposes.) Then again, let us consider having a beam of photons of energy ΔE_{21} and wavelength λ_{21} enter the medium. According to the earlier discussion, and considering the process that can occur is stimulated emission, and we would expect more photons to be generated as the beam progresses. This can be described mathematically in the equation below

$$I = I_0 e^{+\sigma_{21} N_2 L}$$

in which we now have the population density N_2 in the expression along with the appropriate cross section σ_{21} .

POPULATION INVERSION

A **population inversion** exists whenever more atoms are in an excited atomic state than in some lower energy state. The lower state may be the ground state, but in most cases it is an excited state of lower energy. Lasers can produce coherent light by stimulated emission only if a population inversion is present. And a population inversion can be achieved only through external excitation of the atomic population.

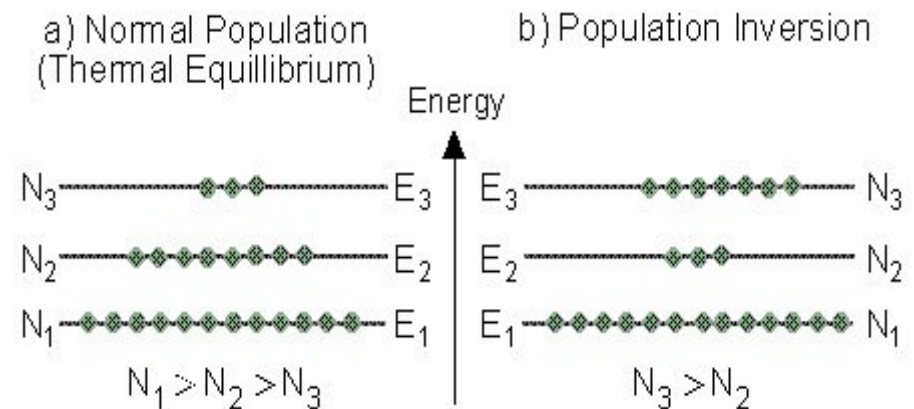

Rami Arieli: "The Laser Adventure" Chapter 2.6 page

POPULATION INVERSION

Now, if population is allowed to be in both level 1 and level 2, both absorption and stimulated emission will occur within the medium and therefore

$$I = I_0 e^{+\sigma_{21}(N_2 - N_1)L}$$

Hence, if more population exists in level 2 than in level 1, N_2 will be greater than N_1 and the exponent of above equation will be positive. The beam will grow and emerge from the medium with a greater intensity than when it entered. In other words, for amplification or gain to occur, the condition must be

$$\frac{N_2}{N_1} > 1$$

Having N_2 be larger than N_1 is known as having a *population inversion*, which is not a normal, naturally occurring relationship.

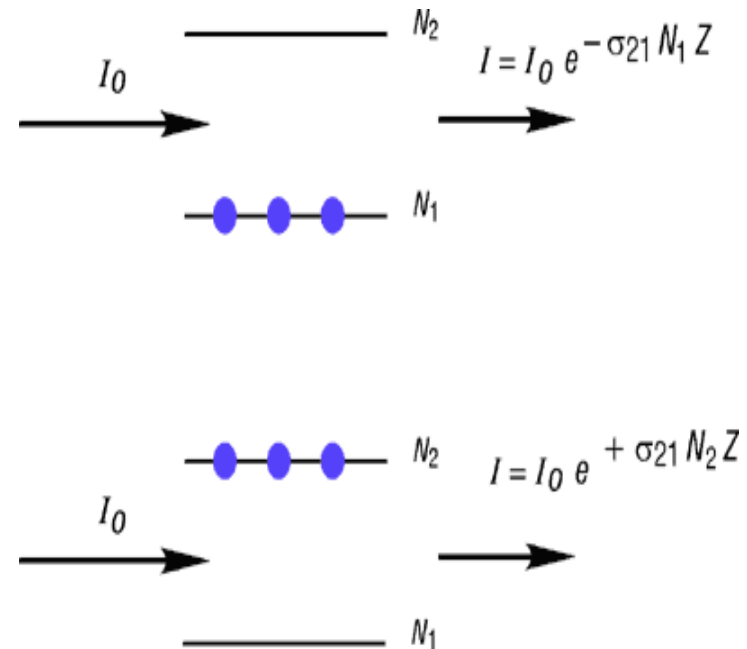

Small-signal-gain coefficient

It is useful to describe the product of σ_{21} and ΔN_{21} as the small-signal-gain coefficient g_{21} or

$$g_{21} = \sigma_{21} \Delta N_{21}$$

$$I = I_0 e^{g_{21} L}$$

By considering the units of both σ_{21} (length²) and ΔN_{21} (1/length³) we can see that g_{21} has the units of 1/length. Hence, if σ_{21} is given in units of cm² and ΔN_{21} is given in units of (1/cm³), g_{21} will be given in (1/cm), more commonly expressed as cm⁻¹. Values of the cross sections σ_{21} and ΔN_{21} , and the small-signal gain g_{21}

Population Inversion in lasing mediums

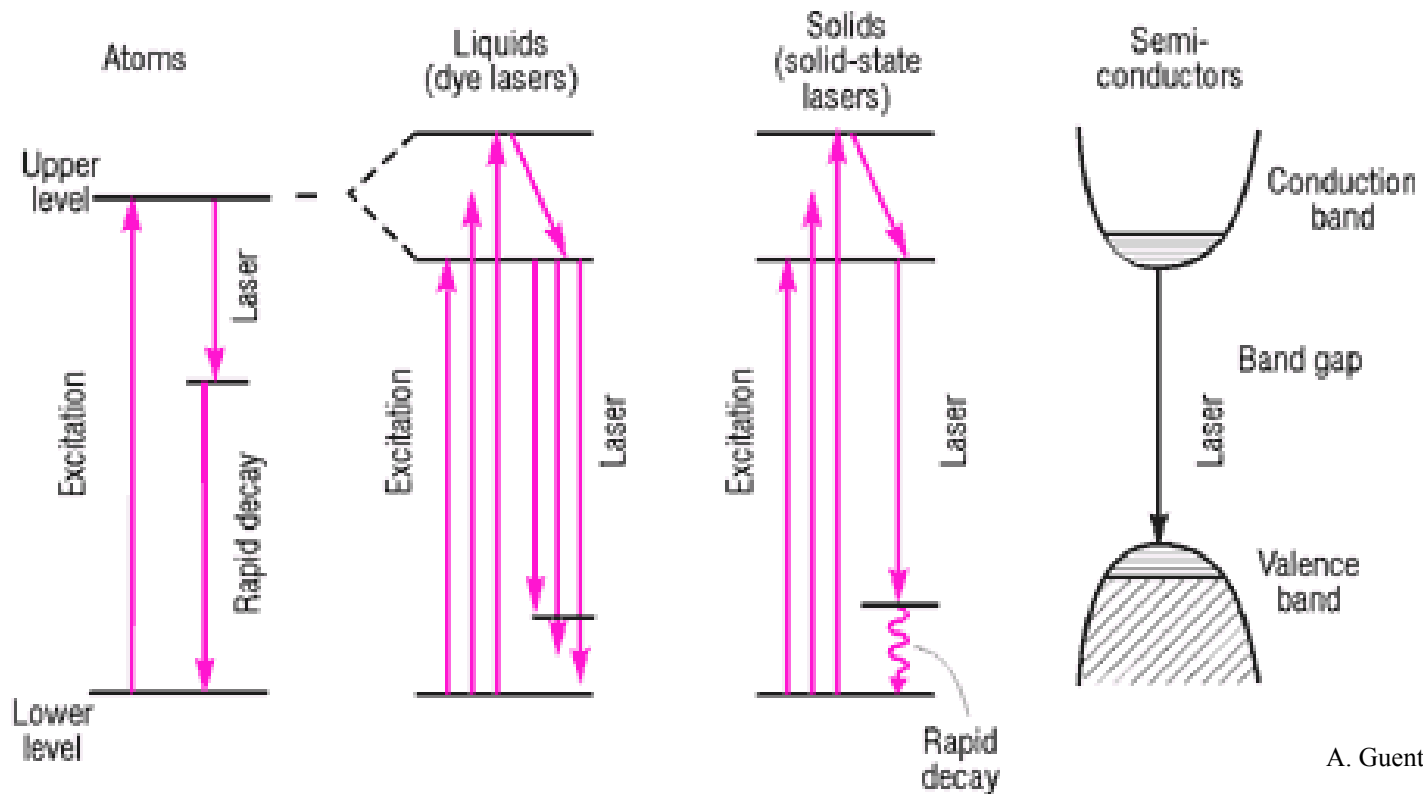

A. Guenther UCONN

Gas Laser

ATOM

- **He-Ne (Helium-Neon)**

Metal Vapor Lasers

- **Cu (Copper) Vapor**
- **Au (Gold) Vapor**

Ionized vapor Lasers

- ***He-Cd (Helium-Cadmium)**

MOLECULE

- **CO₂ (Carbon Dioxide)**
- **N₂ (Nitrogen)**
- **Chemical (HF-DF)**
- **FIR - Far Infrared**
- **Excimer Laser**

ION

- **Ar⁺ (Argon ion)**
- **Kr⁺ (Krypton ion)**

Population Inversion in gas laser

- Applied voltage produces an electric field accelerates the electrons within the gas.
- Excited electrons collide with the gas atoms and excite the atoms to excited energy levels, some of which serve as upper laser levels.
- Lower-lying levels, those to which higher-lying levels can transition, typically decay to the ground state faster than the higher-lying levels, thereby establishing a population inversion between some of the higher and lower levels.
- The laser light then occurs when the higher-lying levels decay to the lower levels while radiating photons at the wavelengths corresponding to the energy separation between the levels.
- In many instances the excitation is a two-step process in which the electrons
 - * first excite a long-lived or metastable (storage) level or they ionize the atom, leaving an ion of that species and another electron. In either case, that level
 - * then transfers its stored energy to the upper laser level via a subsequent collision with the laser species.

HeNe laser

The current pumps the helium atoms to an excited atomic state. The energy of the excited helium atoms is transferred to neon atoms through collisions, and the neon atoms then undergo a transition to a lower energy state that results in lasing.

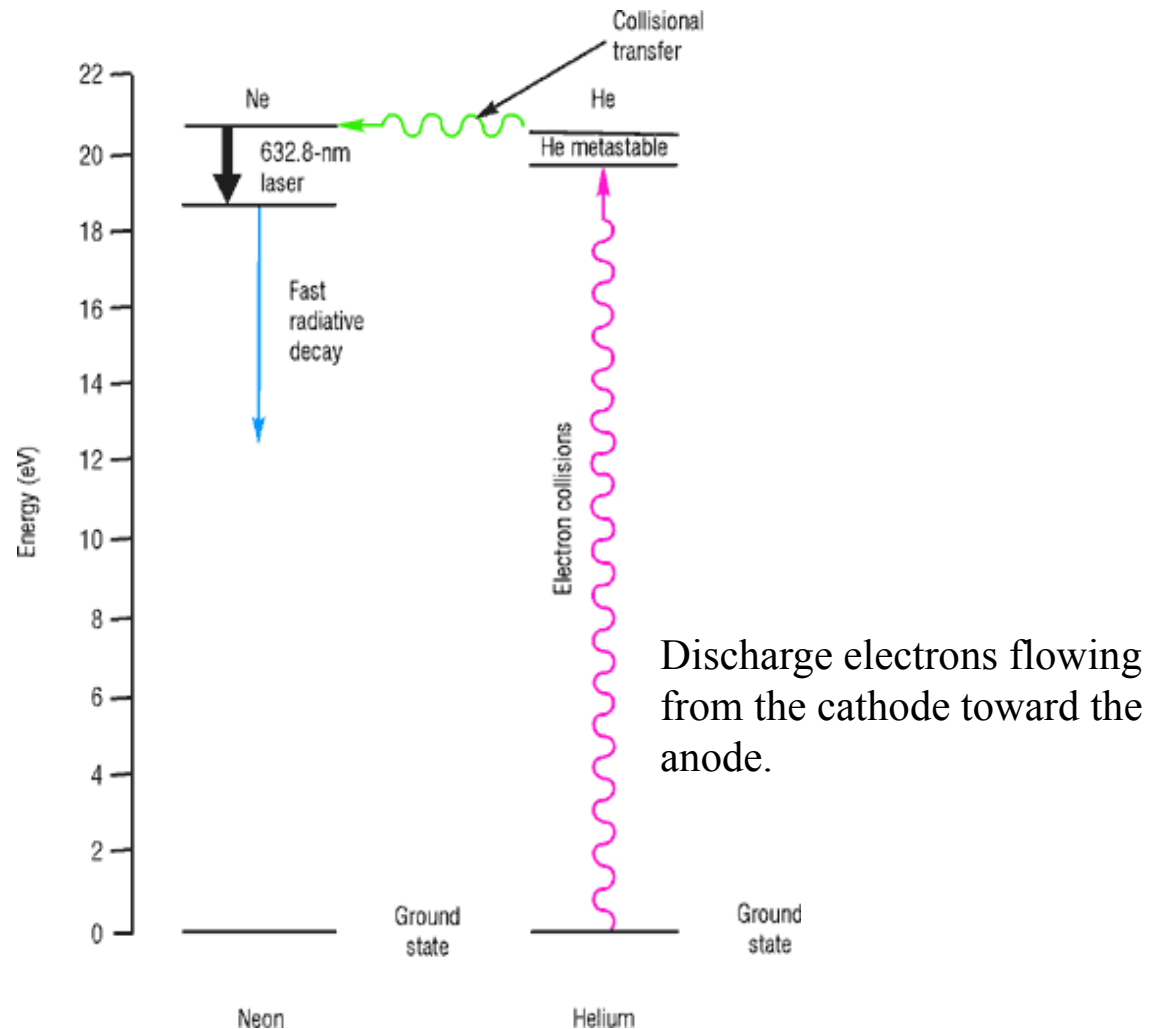

HeNe laser

It was first built in 1961 by Ali Javan. **The active medium is a noble gas Neon (Ne)**, and it is a **4 level laser**. Two **meta-stable energy levels** act as **upper laser levels**. The He-Ne laser have two lower laser levels, so quite a few wavelengths can come out of the transitions between these levels.

The important wavelengths are:

$\lambda_1=0.6328$ [μm] (632.8 [nm]), $\lambda_2=1.152$ [μm], $\lambda_3=3.3913$ [μm], $\lambda_2=0.5435$ [μm]

w.wang

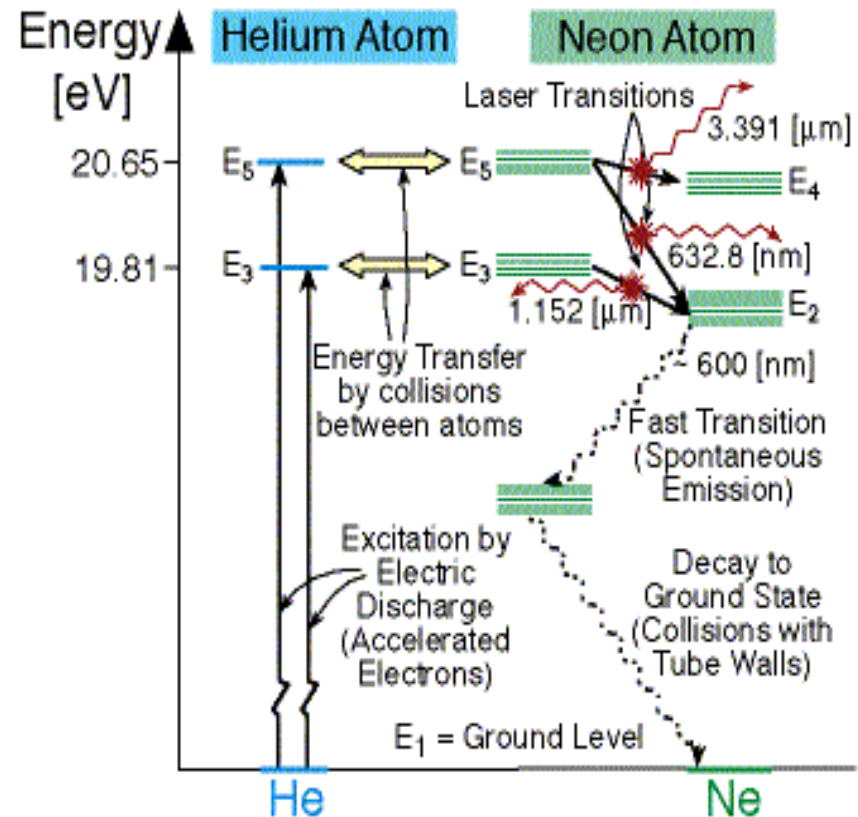

Gas laser

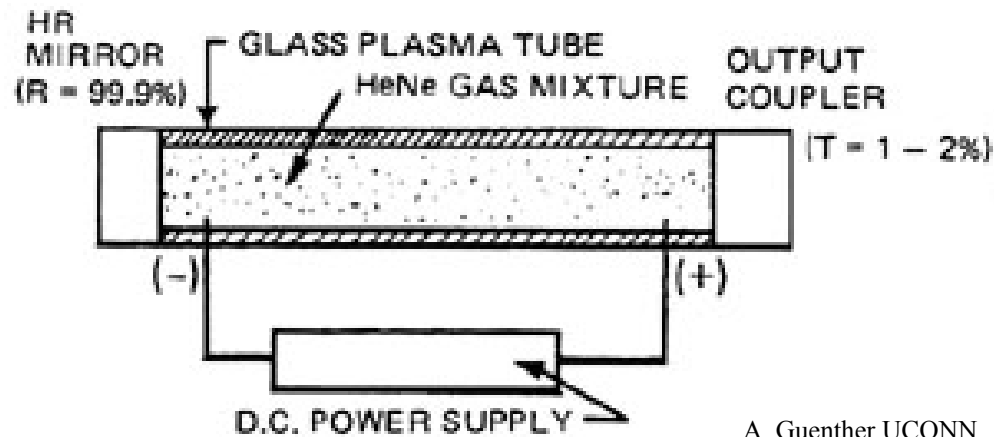

A. Guenther UCONN

One popular type of gas laser contains a mixture of helium (He) and neon (Ne) gases and is illustrated in Figure. The gas mixture is contained at a low pressure within a sealed glass tube called the "plasma tube. The feedback mechanism consists of a pair of mirrors sealed to the ends of the plasma tube. One of these mirrors, the output coupler, transmits 1-2 percent of the light to form a continuous (CW) output beam.

Laser structure

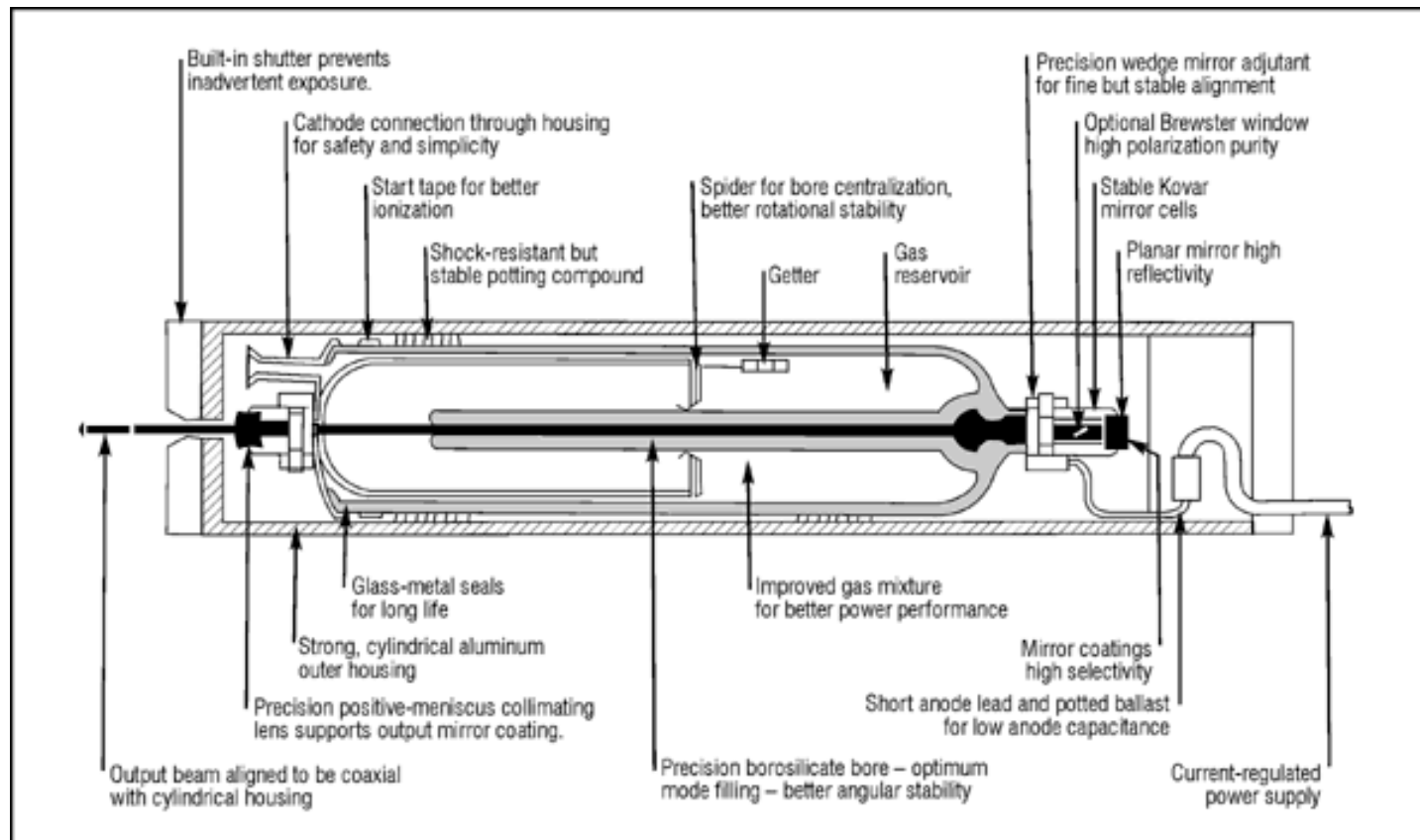

Gain coefficient

For a laser in which the amplifier length has a value of L and the mirrors have identical reflectivities R , with no other losses in the cavity, the threshold condition for the gain coefficient g is given as

$$g = \frac{1}{2L} \ln \frac{1}{R^2}$$

which has dimensions of 1/length. Any value of g higher than above equation will produce a laser beam within the cavity. For a more complex laser cavity in which the mirrors have different reflectivities R_1 and R_2 , and a_1 and a_2 represent other losses within the cavity (beyond the amplifier), the expression for the threshold gain g is given as

$$g = \frac{1}{2L} \ln \left[\frac{1}{R_1 R_2 (1 - a_1)(1 - a_2)} \right] + \alpha$$

The term α represents a potential absorption loss within the amplifier itself, which is present in only a few types of lasers. It is a distributed loss expressed in the same units as g or (1/length). For example, in solid-state lasers it is termed excited state absorption.

Bandwidth of laser gain medium

The bandwidth of the laser gain medium determines the range of wavelengths over which amplification can occur for any specific laser. This bandwidth is expressed in either a wavelength range $\Delta\lambda_G$ or a frequency range $\Delta\nu_G$. These two expressions are related by

$$\Delta\lambda_G = \frac{\lambda^2}{c} \Delta\nu_G$$

in which λ is the laser wavelength and c is the speed of light. The bandwidth of the gain medium is usually determined by the bandwidth over which the spontaneous emission occurs for a given laser transition.

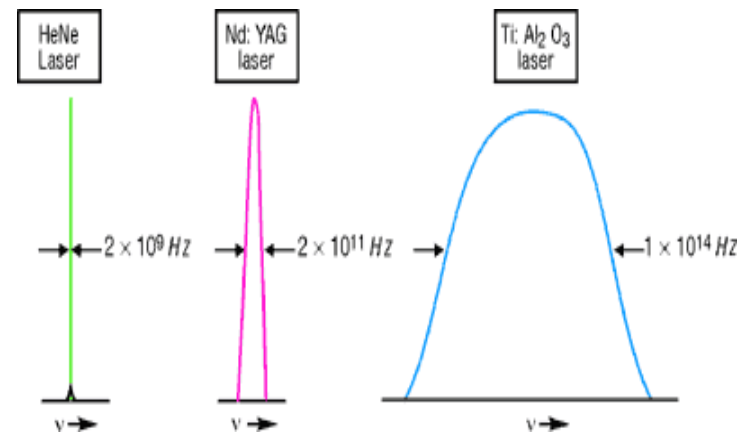

Laser gain bandwidths for the HeNe, Nd:YAG, and Ti:Al₂O₃ lasers

A. Guenther UCONN

Coherence

For longitudinal or temporal coherence, the coherence length ℓ_c is related to the wavelength λ and the total frequency bandwidth of the laser $\Delta\lambda$ by

$$\ell_c = \frac{\lambda^2}{\Delta\lambda}$$

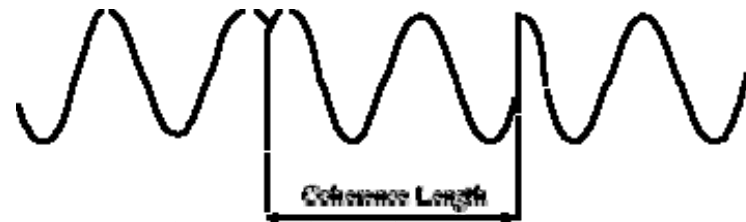

Note: $\Delta\lambda$ is the actual bandwidth of the laser beam given in wavelength units.

For transverse or spatial coherence, the transverse coherence length ℓ_t is related to the laser wavelength λ , the laser source diameter at its origin s , and the distance r the beam has propagated from its origin, by the following relationship.

$$\ell_t = \frac{r\lambda}{s}$$

Argon Ion Laser

The Argon laser was invented in 1964 by **William Bridges** at Hughes. Argon ion laser contains a tube filled with Argon gas which transforms into **plasma** in an excited state.

(**Plasma** is a state of matter in which the electrons are separated from the atoms and molecules, which means that it contains free electrons and ions).

The two main laser transitions are at visible wavelengths:

Blue 0.488 [μm]

green 0.5145 [μm],

but the Argon ion laser emits also in the **UV spectrum:**

0.3511 [μm]

w.wang

0.3638 [μm].

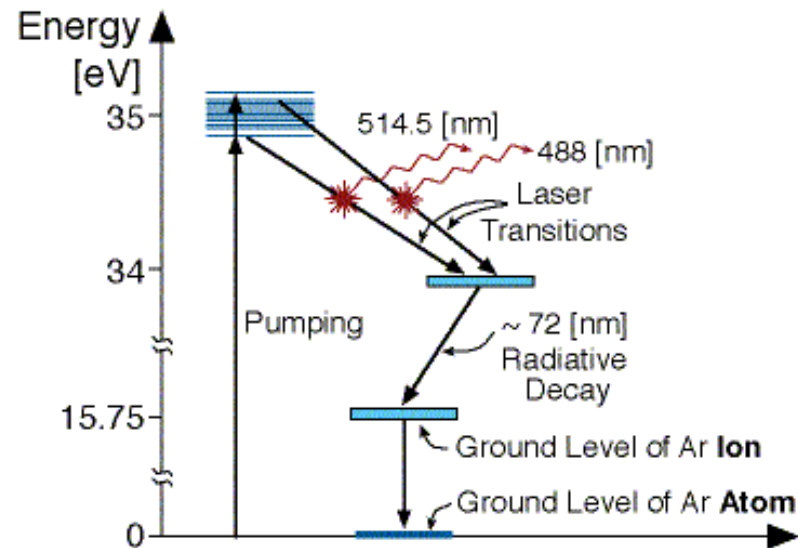

Energy Level Diagram of Ion Argon Laser.

Krypton Laser

The Krypton laser is very similar to the [Argon laser](#), but its efficiency is lower.

This laser has many lines in the visible spectrum, especially in the **yellow to red** part of the spectrum.

The **maximum output power** in each line is about 100 [mW].

The main applications of this laser are in the **art and entertainment** business, to create **fantastic visual effects**.

Nitrogen Laser

The Nitrogen laser was first developed in 1963 and has been sold as a commercial product since 1972.

Laser Action:

The active medium in Nitrogen lasers is Nitrogen gas at pressures of 20 [torr] up to 1 [At].

In some Nitrogen lasers the **gas flows** in the tube, while others have a **sealed tube**. Like most gas lasers, the Nitrogen laser is based on **transitions between vibration energy levels**, and is electrically excited.

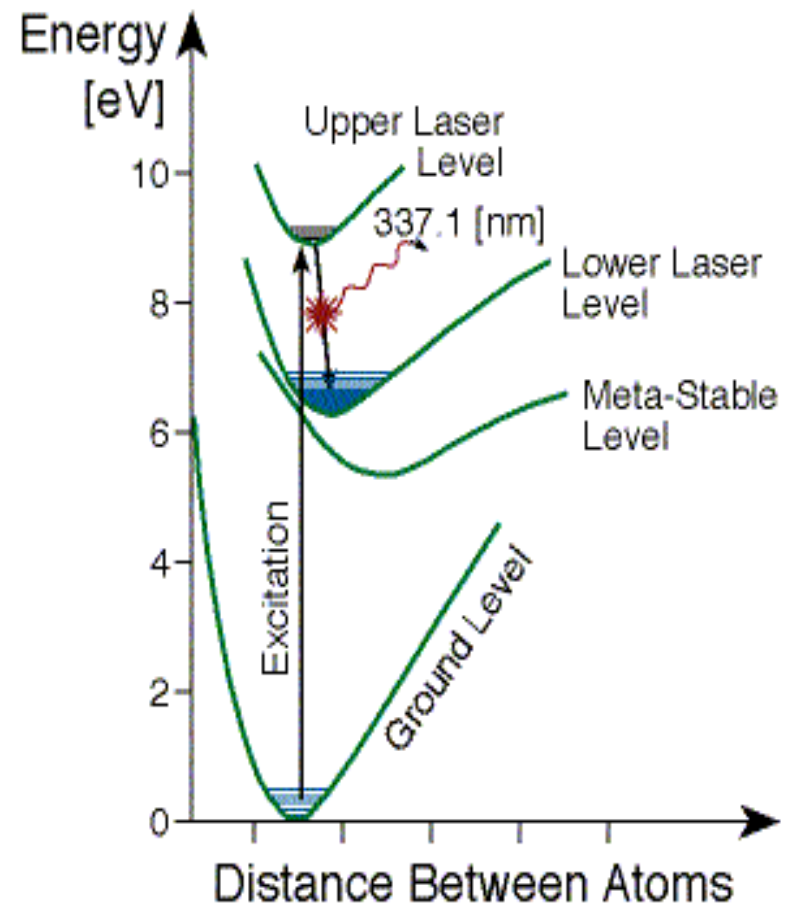

CO₂ laser

Lasing action in a CO₂ molecule was first demonstrated by C. Patel in 1964. He transmitted an electric discharge pulse through pure CO₂ gas in a laser tube, and got a small laser output.

CO₂ is the gas in which the lasing process occurs, but other gas additives to the laser tube improve the total efficiency of the laser.

The standard CO₂ laser includes in the active medium a mixture of CO₂ with N₂ and He. The optimal proportion of these 3 gases in the mixture depends on the laser system and the excitation mechanism. In general, for a continuous wave laser the proportions are:

CO₂:N₂:He - 1:1:8

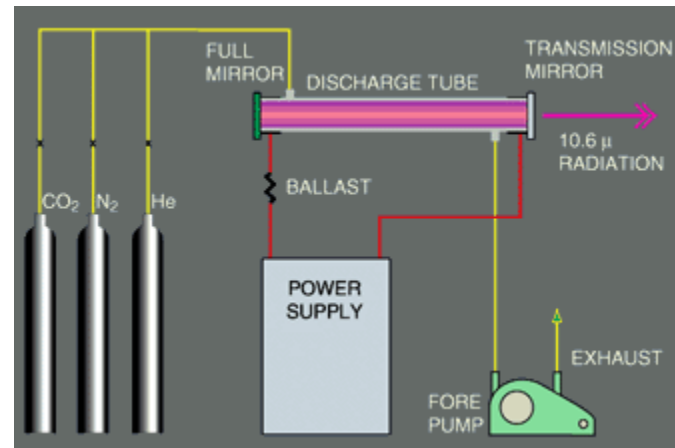

CO₂ laser

CO₂ is a linear molecule, and the three atoms are situated on a straight line with the Carbon atom in the middle. **Three vibrational modes of CO₂ molecule** are illustrated:

1. Symmetric stretch mode (ν_1).
2. Bending mode (ν_2).
3. Asymmetric stretch mode (ν_3).

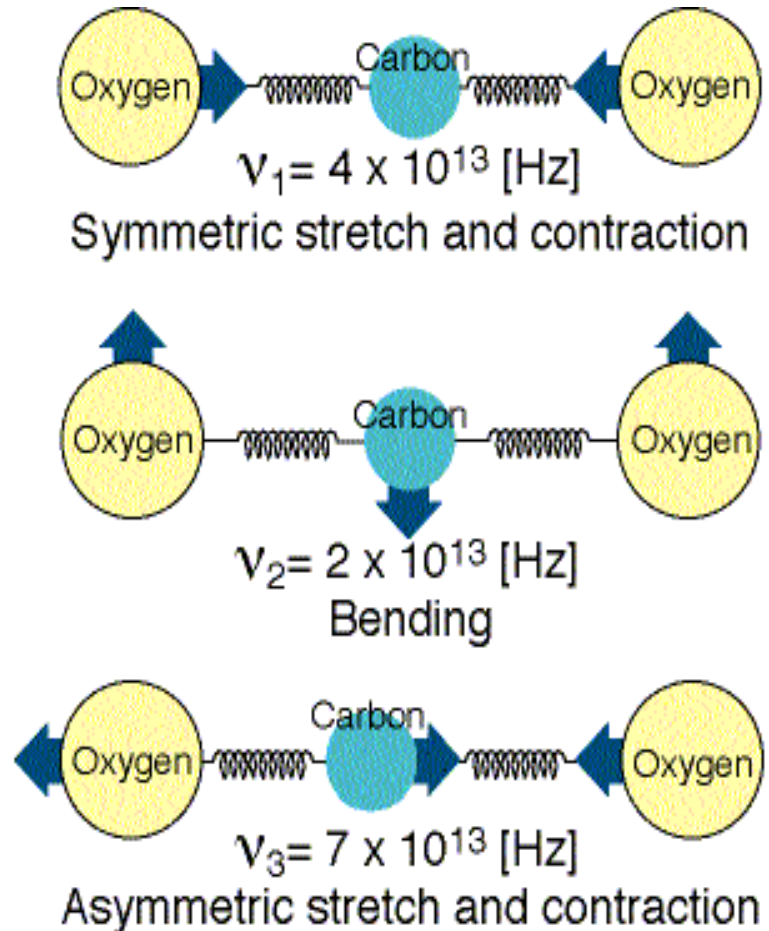

CO2 laser

Transitions between vibrational energy states/levels results in photon emission in the infrared, while transitions between rotational states emit photons in the microwave region.

Necessary mechanisms for operation of the CO2 laser are,

1. Excitation of N2 vibration by electron impact
2. Transfer of vibrational energy from N2 to the nearly resonant ν_3 mode of CO2
3. Laser transition from ν_3 to ν_1 mode.
4. Sharing of population between ν_1 and $2\nu_2$ modes and relaxation within the ν_2 manifold
5. The vibrational energy in the ν_2 manifold converted into translational energy by collisions with He.

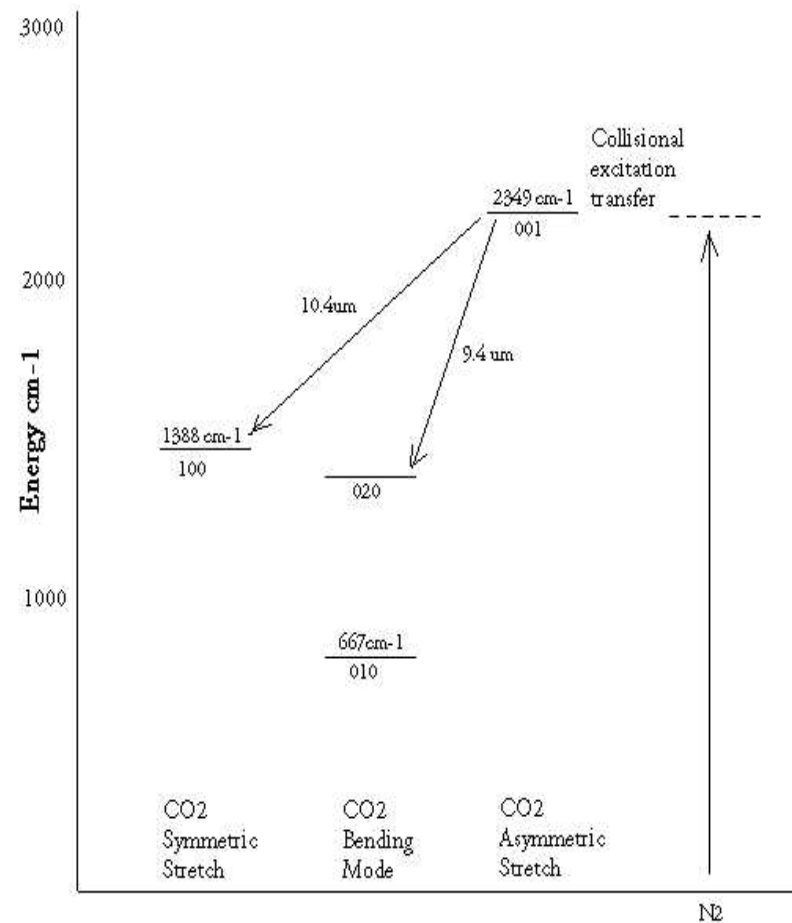

<http://www.phy.davidson.edu/StuHome/sethvc/Laser-Final/co2.htm>

Chemical Laser

The chemical laser is an example of a laser where the **pump energy** comes from a **chemical reaction** between two atoms.

The chemical laser is a member of the family of **Gas Dynamic Lasers:**

Gas dynamic lasers are based on **rapid expansion** of hot, high pressure gas, through nozzles into a near vacuum. This rapid expansion reduce the gas temperature.

As a result, since the transfer of the molecules to the ground state takes more than the time of rapid expansion, we get at low temperature many molecules at excited levels. Thus, "population inversion".

The gas usually flow through the nozzles in a transverse flow (perpendicular to the optical axis of the laser), so many nozzles can operate at the same time, yielding **high power from the laser**.

The first chemical laser, which was operated in the pulsed mode, was developed in 1965 by J. V. V. Kasper, and G. C. Pimental.

The lasing action of the chemical laser is usually based on **vibrational transitions of diatomic molecule**.

Far Infra-Red (FIR) Lasers

Far Infra-Red (FIR) lasers emit radiation in the **Far-Infra-Red spectrum** (wavelength range 12-1000 [μm]).

The wavelength range greater than 100 [μm] is sometimes called **sub-millimeter wave**.

Far Infra-Red (FIR) lasers are gas lasers, and their **lasing action occur between rotational levels of the gas molecules of the active medium**. Usually these transitions are within the same vibrational level.

The active medium in FIR lasers is usually a gas of simple organic molecule such as:



Because of the **very narrow width** of each energy level of these materials, it is inefficient to optically pump them with ordinary light sources.

The best way to achieve **population inversion** in these lasers is to **pump them with another laser** at shorter wavelength. Usually CO_2 laser is used for pumping.

Excimer Laser

There are lasers in which the required conditions for lasing are achieved in exotic ways.

As an example, we shall examine a family of lasers in which the radiation is emitted from a molecule which only exists for a very short time.

This molecule is composed of an atom of **noble gas**: Argon, Krypton or Xenon, and an atom of **halogen**: Fluorine, Chlorine, Bromine or Iodine.

An Excimer is a molecule which has a bound state (existence) only in an excited state.

In the ground state this molecule does not exist, and the atoms are separated.

The excited state exists for a very short time, less than 10 nanoseconds.

The name **Excimer** comes from the combination of the two words: *excited dimer*, which means that the molecule is composed of two atoms, and exists only in an excited state.

(Some scientists consider this molecule to be a complex, and they call the laser "**Exiplex**").

Copper vapor laser (CVL)

This laser was attractive because of its **relative high efficiency (up to 1%) for lasers in the visible spectrum range, and the high pulse power achieved.**

Copper Vapor Laser Structure

Copper vapor laser is a gas laser, build as a tube with windows at both ends. The tube is filled with an inert gas and a small quantity of pure copper.

In order to have **copper vapor**, the metal needs to be at very high temperatures, so the tube is build from Alumina or Zirkonia, which are high temperature resistant materials.

The tube diameter is 10-80 [mm], and it contain Neon gas at a pressure of 25-50 [Torr].

Helium-Cadmium Laser

Helium-Cadmium lasers can be categorized among either:

- Metal vapor lasers - Cadmium is a metal, the lasing action in Helium Cadmium laser occurs between energy levels of **Cadmium ions**, so the lasing medium is ionized metal vapor.
- Ion gas lasers - The properties of Helium-Cadmium laser are similar to those of Helium-Neon laser which is a neutral atom gas laser.

The He-Cd laser is a gas laser, and the metal Cadmium can be transform into the gas phase by heat.

The excitation to the upper laser level of the Cadmium atoms in the gas is similar to the excitation process of the Neon gas in a Helium-Neon laser: Helium atoms are excited by collisions with accelerated electrons, and than they pass their energies to Cadmium atoms by collisions.

Thus, the main application of the He-Cd laser is in the optics laboratory, for fabricating holographic gratings. (UV, 351nm)

Dye Laser

A **dye laser** can be considered as a special device to convert electromagnetic radiation from one wavelength, to another wavelength which can be tuned.

The output of a dye laser is always a **coherent radiation tunable over a specific spectrum region, determined by the Dye material.**

History:

Dye laser was first demonstrated in 1965 at IBM laboratories in the US, by **Peter P. Sorokin and J. R. Lankard.**

They discovered the dye laser action during a fluorescence research of organic dye molecules, which were excited by [Ruby laser](#).

In 1967 scientists discovered the possibility to tune the emitted wavelength, using a grating at the end of the optical cavity

Population inversions in liquids

There are some molecules however, namely organic dye molecules, that do have a sufficiently long lifetime in an upper energy level (of the order of 1–5 nsec) so they can participate in the laser process by being excited to an upper laser level. These molecules also have the ability to radiate the energy from that level rather than lose the energy due to decay by collisions. Those molecules are the dyes that are used to color cloth and other objects that we use in our everyday life

When dissolved in a solvent such as alcohol or water, they can be concentrated in sufficient quantity to be used as a laser gain medium.

When the light is applied to the dye solution, it is absorbed at certain wavelengths by the dye as described by absorption equation, placing the dye molecules in highly excited upper laser levels. A population inversion is then produced between those levels and a very broad range of lower-lying energy levels, thereby allowing the possibility for a *wide range of laser wavelengths* to be produced within the gain medium. Those lower levels are not initially pumped by the light and therefore are sufficiently empty to produce the inversion. Dye lasers thus allow the possibility of wide wavelength *tunability* and have been used extensively in doing a variety of spectroscopic studies in which very specific laser wavelengths are desired.

Population inversions in liquids

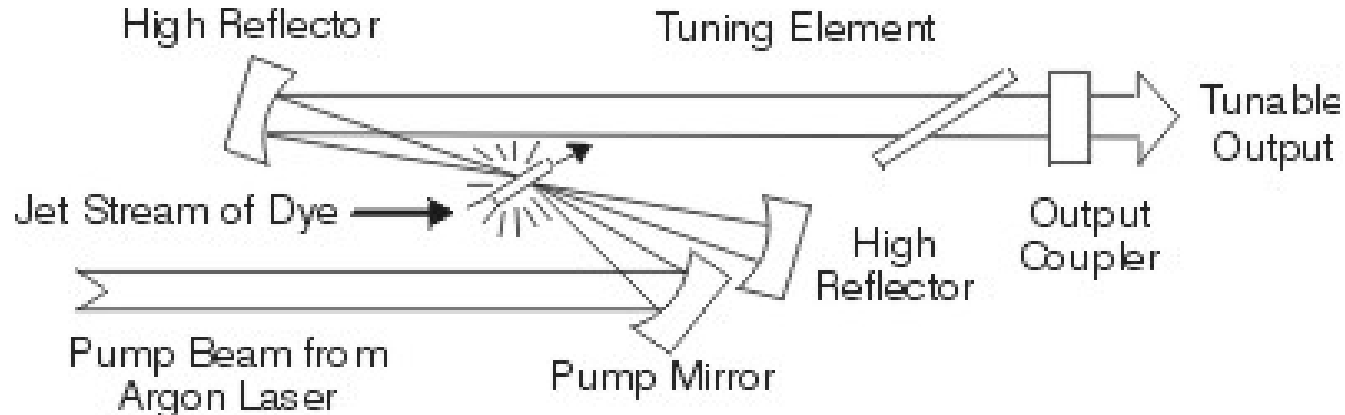

A. Guenther UCONN

The pump source is an argon laser, whose beam is focused to a small spot. The argon laser is a gas laser which emits blue and green light. The dye flows in a high velocity jet with the argon laser beam focused on the jet. The wavelength of the output is adjusted by the tuning element. One of the most important features that dye lasers offer is tunability, that is, the color of the output beam can be varied by adjusting the intercavity tuning element and also by changing the type of dye that is used. The monochromatic output of available dye lasers can be tuned over a broad range, from the ultraviolet, to the near infrared. Liquid dye lasers that can be tuned to any visible wavelength, and to portions of the infrared and ultraviolet, are commercially available in both pulsed and **continuous models**. Dye lasers are chosen for applications, like spectroscopy, in which tunability is important.

Solid State Lasers

Insulator

- **Ruby Laser**
- **Nd-Yag and Nd-Glass Lasers**
- **Color Center Laser**
- **Alexandrite Laser**
- **Ti - Sapphire Laser**

Semiconductor

- **Laser Diodes**

Population inversions in crystalline solids and glasses

As in the case of liquids, when energy levels in solids are excited, typically by irradiating those solids with light, the levels tend to decay much more rapidly via collisions with their surrounding neighbors rather than by radiating their energy in the form of light. In a few cases, however, specific types of atoms are embedded into a transparent host material (such as a specific crystalline solid or a glass) at concentrations of up to 1 part in 100, and the atoms radiate their energy rather than decay by collisions. These specific types of atoms, such as [chromium or neodymium](#), consist of a radiating electron surrounded by a “screen” of other electrons that protect that radiating electron from being bombarded by collisions from neighboring atoms. The consequence is that the atoms can absorb pump light that passes through the transparent host medium and can then subsequently radiate that energy. Gemstones such as rubies fall into that category. Ruby, a desired gemstone and also the material that comprised the gain medium for the first laser, consists of chromium atoms doped into a transparent sapphire (Al_2O_3) host crystal. The color of the ruby crystal is determined by the chromium atoms, which absorb light in the blue and green regions of the spectrum and radiate in the red.

Ruby Laser

Ruby laser was the **first man made laser**, which was build by **Theodore Maiman in 1960**.

Ruby is a synthetic crystal of Aluminum Oxide (Al_2O_3), and is more familiar in daily life as a **precious stone** for jewel.

The chemical structure of Ruby is of **Al_2O_3** (which is called **Sapphire**), with impurity of about 0.05% (by weight) of Chromium Ions (Cr^{+3}).

The active ion is Cr^{+3} , which replace Al atom in the crystal. This ion causes the red color of the crystal. The impurity ion of Cr^{+3} is responsible for the energy levels which participate in the process of lasing.

SOLID CRYSTALLINE AND GLASS LASERS

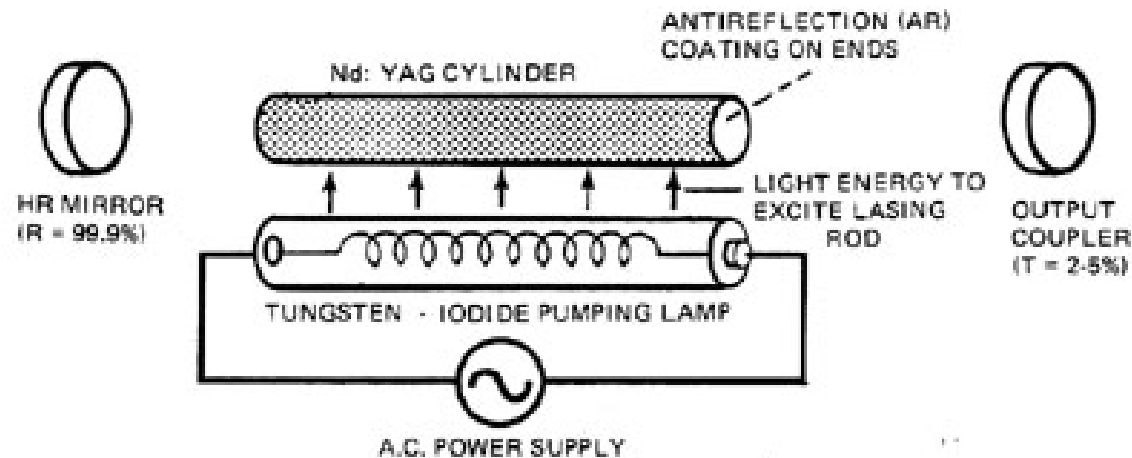

A. Guenther UCONN

The active medium is a cylinder of laser crystal whose ends have been cut parallel and polished. Antireflection coatings have been applied to the rod ends to reduce losses. The excitation mechanism for this particular laser is a tungsten filament lamp attached to an ac power source. Larger models utilize do krypton arc (gas discharge) lamps as pumping sources. Both types of lamps provide continuous optical pumping to the laser crystal. The mirrors of the Nd:YAG (yttrium-aluminum-garnet) laser usually are mounted separately from the active medium as shown, but one of the mirror coatings sometimes is applied directly to one end of the rod.

Pump Sources

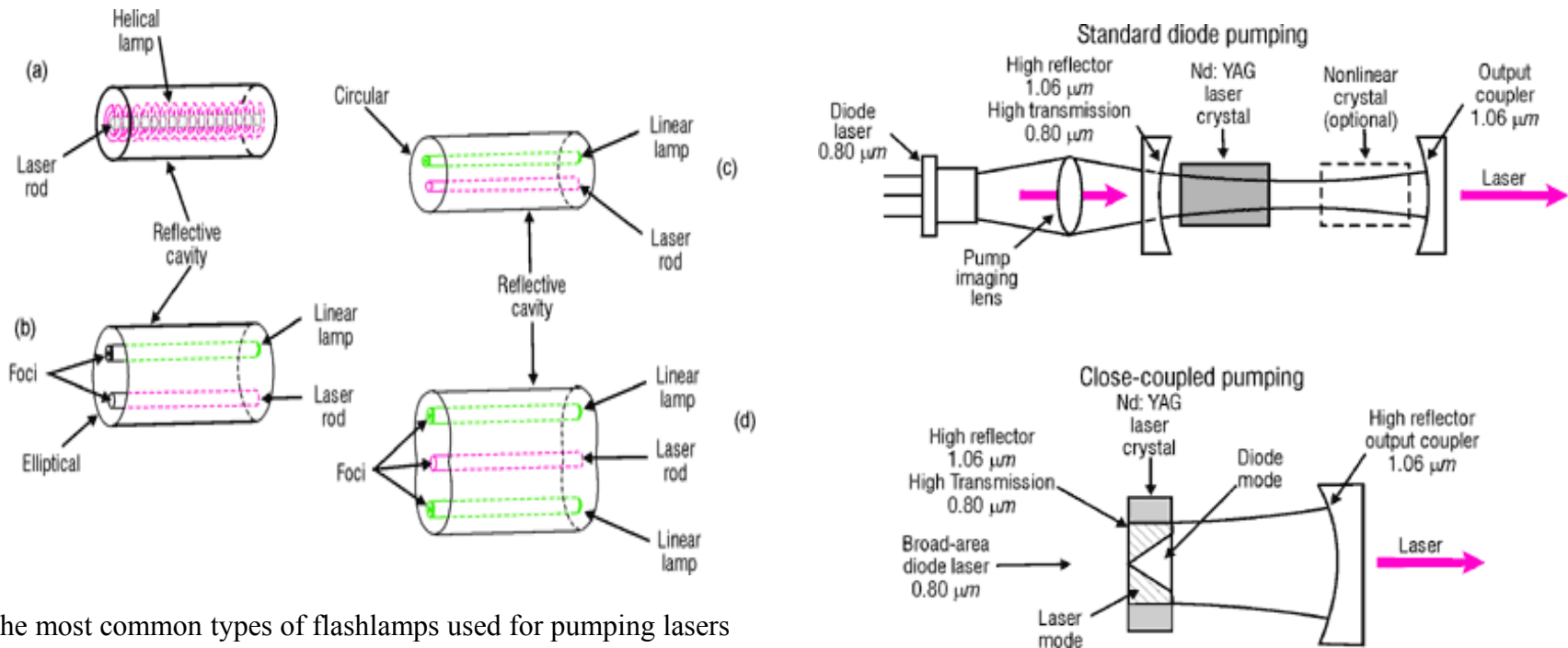

A. Guenther UCONN

The most common types of flashlamps used for pumping lasers are narrow, cylindrical quartz tubes with metal electrodes mounted on the ends, filled with a gaseous species such as xenon that serves as the radiating material within the lamp. Xenon is the most common species because of both its radiating efficiency and its emission of a broad spectrum of wavelengths from which to choose in matching the lamp emission to the pumping absorption bands of the laser.

w.wang

Pumping lasers include the argon ion or doubled Nd:YAG cw lasers for pumping titanium-sapphire lasers, excimer lasers for pumping dye lasers, and gallium arsenide semiconductor lasers for pumping Nd:YAG lasers.

Nd Laser

In Nd laser **Nd⁺³ ions** (as impurities of up to a few percent by weight) are replacing the atoms of the solid host in the active medium.

Three **known solid hosts** are used for Nd-YAG laser where Nd⁺³ ions are added as impurities:

- **Glass.**
- **YAG (Yttrium Aluminum Garnet) Crystal.**
- **YLF (LiYF₄) Crystal.**

The choice between the three possible hosts is according to the intended use of the laser:

- **Glass** is used as the host material when a **pulsed laser** is needed, with each pulse at high power, and the pulse repetition rate is slow.

The active medium of Nd-Glass Laser can be manufactured in a shape of **disk or rod**, with diameters of up to 0.5 meter (!) and length of up to several meters (!). Such dimensions are possible because glass is isotropic material, cheap, and can be easily worked to the right shape.

High percentage (up to about 6%) of Nd ions can be added to glass as impurity.

The **problem** with glass as a host is its **poor thermal conductivity**. Thus cooling the laser when it operates continuously or at high repetition rate is difficult.

- **YAG crystal** is used for **high repetition rate pulses** (more than one pulse per second). In this case a large amount of heat need to be transferred away from the laser, and **the thermal conductivity of the YAG crystal is much higher than that of glass.**

- YAG crystal with the high quality needed for lasers can be made with diameters of 2-15 [mm] and at lengths of 2-30 [cm].

- **The price of a YAG laser rod is high, since growing crystals is a slow and complicated process.**

- The percentage of Nd ions in the YAG host is 1-4% by weight.

Erbium fiber

Fiber lasers were first operated in Nd-doped glass fibers, but the fiber laser of major current interest is the erbium-doped fiber laser operating at 1.4 to 1.6 μm . This fiber laser can be spliced into a normal transmitting optical fiber, and, when optically pumped with a semiconductor laser at either 980 nm or 1.48 μm , it provides amplification to a communication signal that is being transmitted through the fiber. The pump light is fed into the fiber line—with a beam-combining device—thereby merging with the signal. This laser amplifier is especially useful in undersea optical fiber cables transmitting phone and data information between continents.



Erbium Fibre Amplifier
Courtesy E-Bay

Population inversions in semiconductors

Inversions in semiconductors are produced when joining a p -doped semiconductor material with an n -doped semiconductor material in a similar way to that of producing a transistor to create a pn junction. The n -doped material contains an excess of electrons and the p -doped material has an excess of holes (a material with excess positive charge). When a voltage is applied across the junction, with the positive voltage on the p side, the electrons are pulled through the junction toward the positive electrode and the holes are attracted to the negative side, producing an electrical current flow across the junction. The electrons and holes meet within the junction and are attracted to each other because of opposite charges. When they meet, they recombine and emit radiation and also can produce a population inversion. This inversion occurs between energy levels located above and below the semiconductor bandgap, the gap in energy below which the material is transparent. This energy typically corresponds to a wavelength in the infrared, and hence most semiconductors radiate in the infrared and are not transparent in the visible spectral region like glass is. However, semiconductor lasers are under development to operate in the green and blue regions of the spectrum. At very low currents, a population inversion does not occur even though recombination radiation is emitted. In fact, such nonlaser-like emission is the source of radiation from a light-emitting diode (LED). In comparison, to produce a population inversion, a very high current density is applied within the junction region. However, this high current density leads to excessive heat deposition in the material; therefore a significant part of the development of semiconductor lasers involves how to remove the heat, or to make smaller junctions so that less current is required. The material and its corresponding energy bandgap determine the laser wavelength.

Semiconductor Lasers

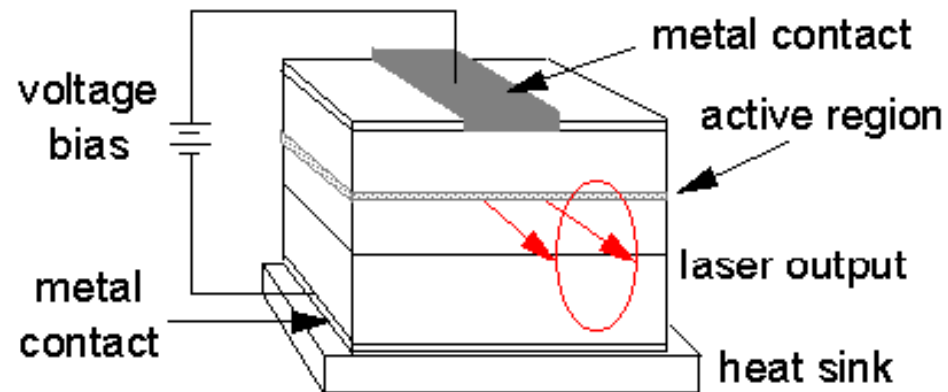

© 1996 B. M. Tissue, www.scimedia.com

Semiconductor lasers are light-emitting diodes within a resonator cavity that is formed either on the surfaces of the diode or externally. An electric current passing through the diode produces light emission when electrons and holes recombine at the p-n junction. Because of the small size of the active medium, the laser output is very divergent and requires special optics to produce a good beam shape. These lasers are used in optical-fiber communications, CD players, and in high-resolution molecular spectroscopy in the near-infrared. Diode laser arrays can replace flashlamps to efficiently pump solid-state lasers. Diode lasers are tunable over a narrow range and different semiconductor materials are used to make lasers at 680, 800, 1300, and 1500 nm.

Semiconductor Lasers

Semiconductor lasers are quite different from conventional lasers. In particular:

- 1.The gain of the laser material is very high and is generated by a population inversion between the conduction and valence bands of the semiconductors. In some sense, a semiconductor laser is a two-state laser system.**
- 2.Since the electromagnetic mode is on the order of the size of the laser device, then the transverse mode of the semiconductor laser is quite different from that of a conventional laser. In particular, the beam is *not Gaussian*, the beam profile tends to be elliptical, and the beam divergence tend to be large.**
- 3.The gain spectrum is quite large (many THz or hundreds of angstroms).**
- 4.The short cavity (several hundred microns) means that the longitudinal mode spacing is much larger than that of a conventional gas or solid state laser (on the order of GHz or angstroms).**

Semiconductor Lasers

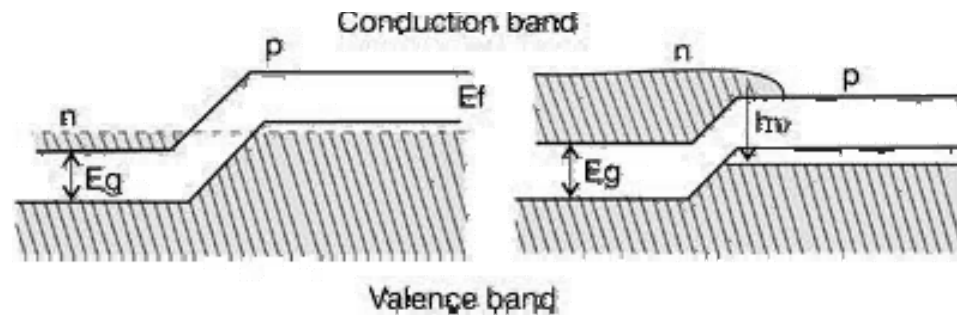

Band structure near a semiconductor p-n junction.
Left: No forward-bias voltage. Right: Forward-bias voltage present

shows the relative populations of the energy bands on both sides of a p-n junction with no voltage applied to the diode. The n-type material contains electrons which behave as the current carriers in its conduction band, whereas the p-type material has holes for carriers in its valence band. When a forward voltage is applied to the diode, the energy levels are caused to shift. Under these conditions there is a significant increase in the concentration of electrons in the conduction band near the junction on the n-side and the concentration of holes in the valence band near the junction on the p-side.

The electrons and holes recombine and energy is given off in the form of photons. The energy of the photon resulting from this recombination is equal to that associated with the energy gap. In light-emitting diodes (LED) this light energy is transmitted out through the sides of the junction region. For the LED, all of the light is created by spontaneous emission due to electron and hole recombination. In semiconductor lasers the junction forms the active medium, and the reflective ends of the laser material provide feedback. Because of this feedback in diode lasers, most of the light is created by stimulated emission.

Simplest (and earliest) type of gallium arsenide laser

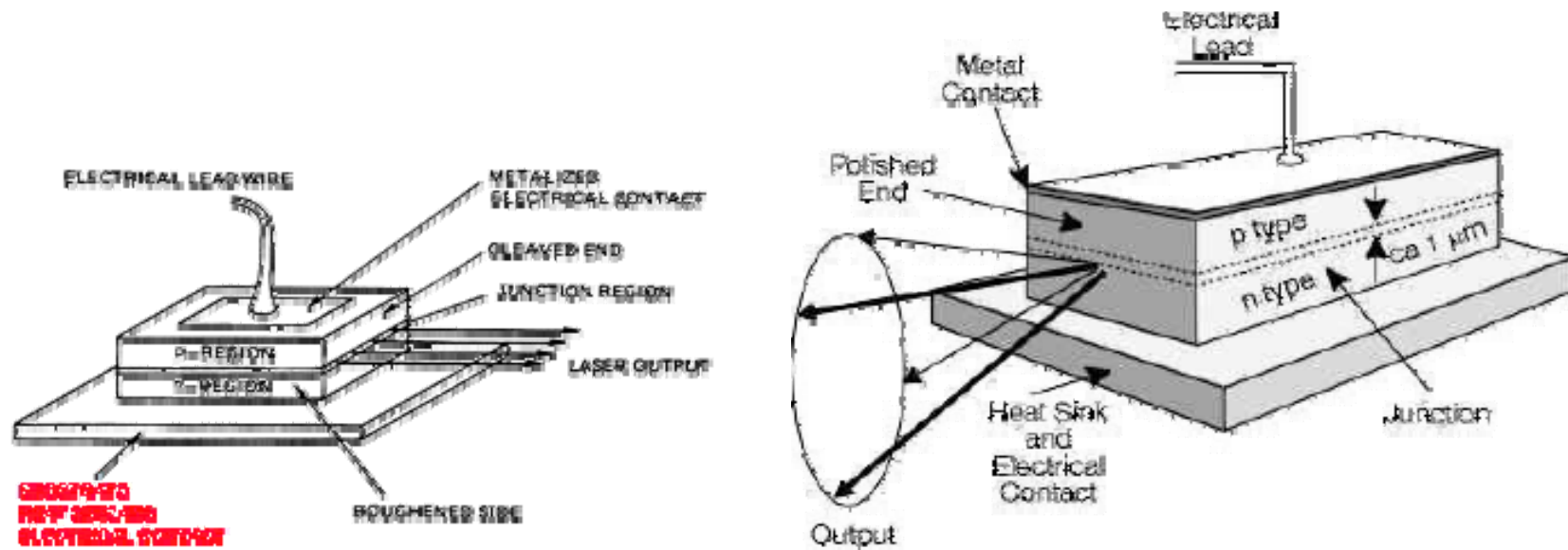

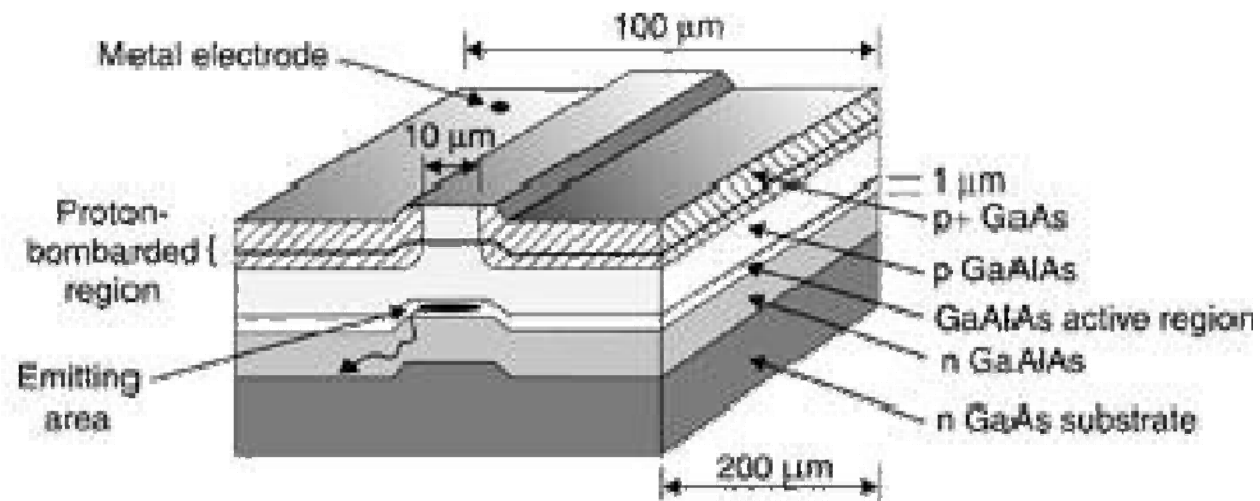

Modern diode lasers are formed of structures that contain several thin layers of material of varying composition.

Homojunction diode lasers

Structure and index of refraction for various types of junction in the aluminum gallium arsenide system.

Top: Homojunction.

Middle: Single heterojunction.

Bottom: Double heterojunction

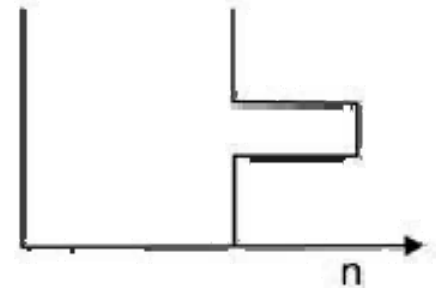
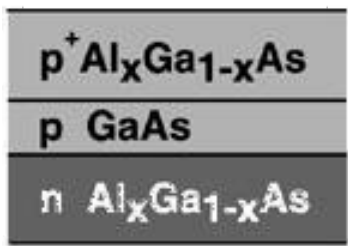
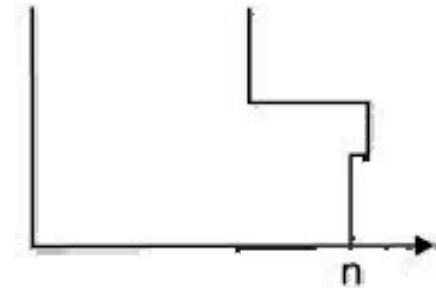
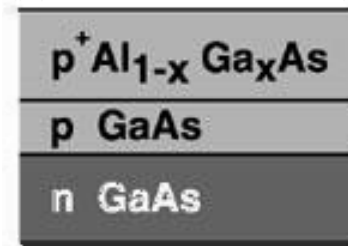
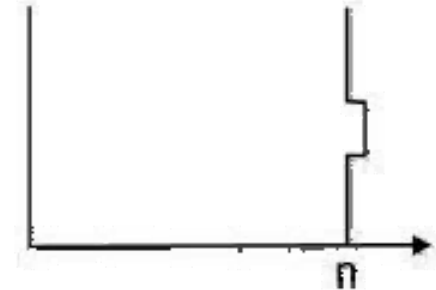

a simplified classification scheme showing some of the major subdivisions of diode lasers and their relationship

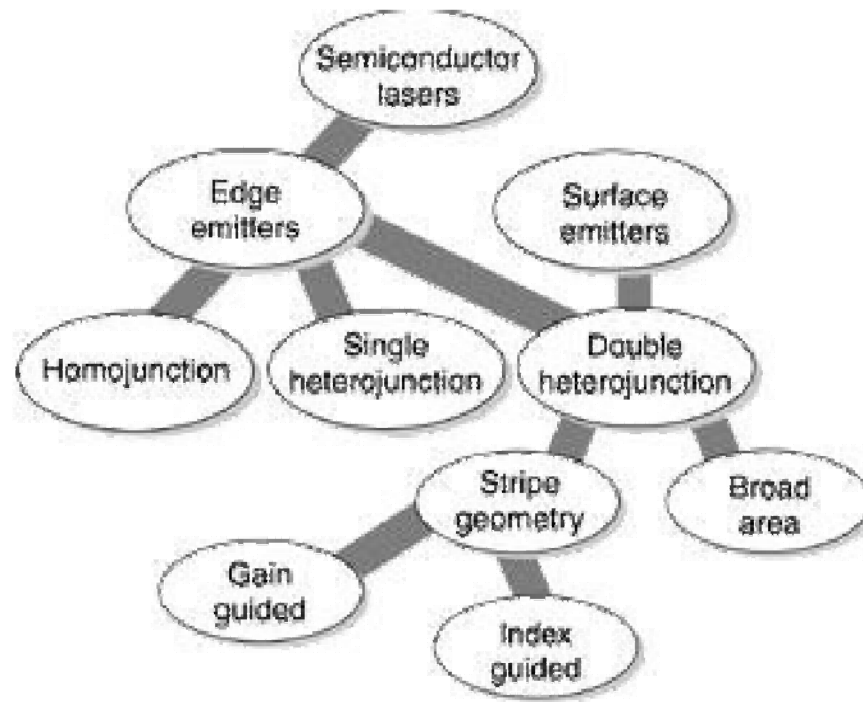

Amplification

A semiconductor laser amplifier is a forward bias heavily doped p-n junction fabricated from a direct gap semiconductor materials. The injected current is sufficiently large to provide optical gain. The gain coefficient $g(\nu)$ of the laser amplifier has a peak value r_p that is approximately proportional to the injected carrier concentration, which in turn, proportional to the injected current density J

$$r_p \sim \alpha(J/J_t - 1), \quad J_t = \Delta n_T e l / \eta_{int} \tau_r$$

Where τ_r = electron-hole recombination lifetime

$\eta_{in} = \tau / \tau_r$ is the internal quantum efficiency

l = thickness of the active region

α = thermal equilibrium absorption coefficient

Δn_T and J_t are injected-carrier concentration and current density just to make the semiconductor transparent.

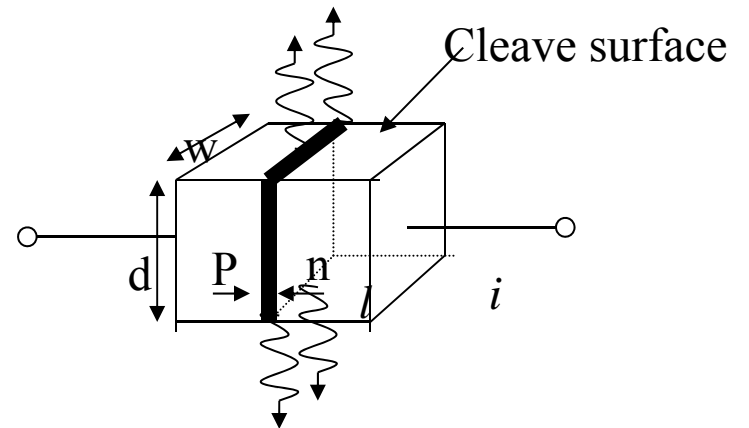

Feedback

The feedback is usually obtained by cleaving the crystal planes normal to the Plane of the junction, or by polishing two parallel surfaces of the crystal. The active region serves as a planar-mirror optical resonator of length d And cross-sectional area lw . The reflectance at the Semiconductor-air interface is

$$R = (n-1/n+1)^2$$

For GaAs, $n=3.6$ and $R=0.32$

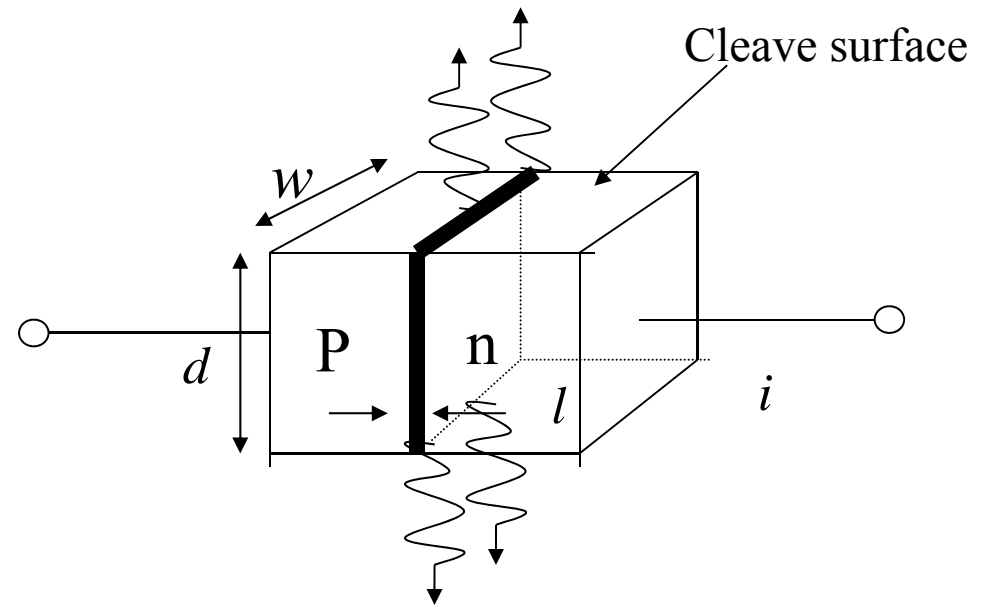

Resonator Losses

The principle source of resonator loss arises from the partial reflection at the surfaces of the crystal. For a resonator of length d the reflection loss coefficient is

$$\alpha_m = \alpha_{m1} + \alpha_{m2} = (1/2d)\ln(1/R_1R_2)$$

If two surfaces have the same reflectance $R_1=R_2=R$, then $\alpha_m = (1/d)\ln(1/R)$.

Include confinement factor Γ which represents the fraction of the optical Energy lying within the active region (l), *the total loss*

$$\alpha_r = 1/\Gamma(\alpha_s + \alpha_m)$$

Where α_s represents other sources of loss including free carrier absorption in and scattering from optical inhomogeneities.

Gain Condition: Laser threshold

The laser oscillation condition is the gain exceed the loss, $r_p > \alpha_r$, as discussed in the earlier section. The threshold gain coefficient is therefore α_r . Set $J = J_t$ and $r_p = \alpha_r$, the threshold injected current density J_t is

$$J_t = J_T(\alpha_r + \alpha)/\alpha \quad \text{or} \quad I = JA$$

Where the transparency current density,

$$J_T = el\Delta n_T/(\eta_i\tau_r) \quad \text{or} \quad i_T = J_T A; A = wd$$

Smaller J_t indicates superior performance, maximize η_i and minimize α_r , minimize transparent injected-carrier concentration Δn_T and l . however, l is reduced beyond a point the α_r increases because the confinement factor Γ

Gain Condition (Laser Threshold)

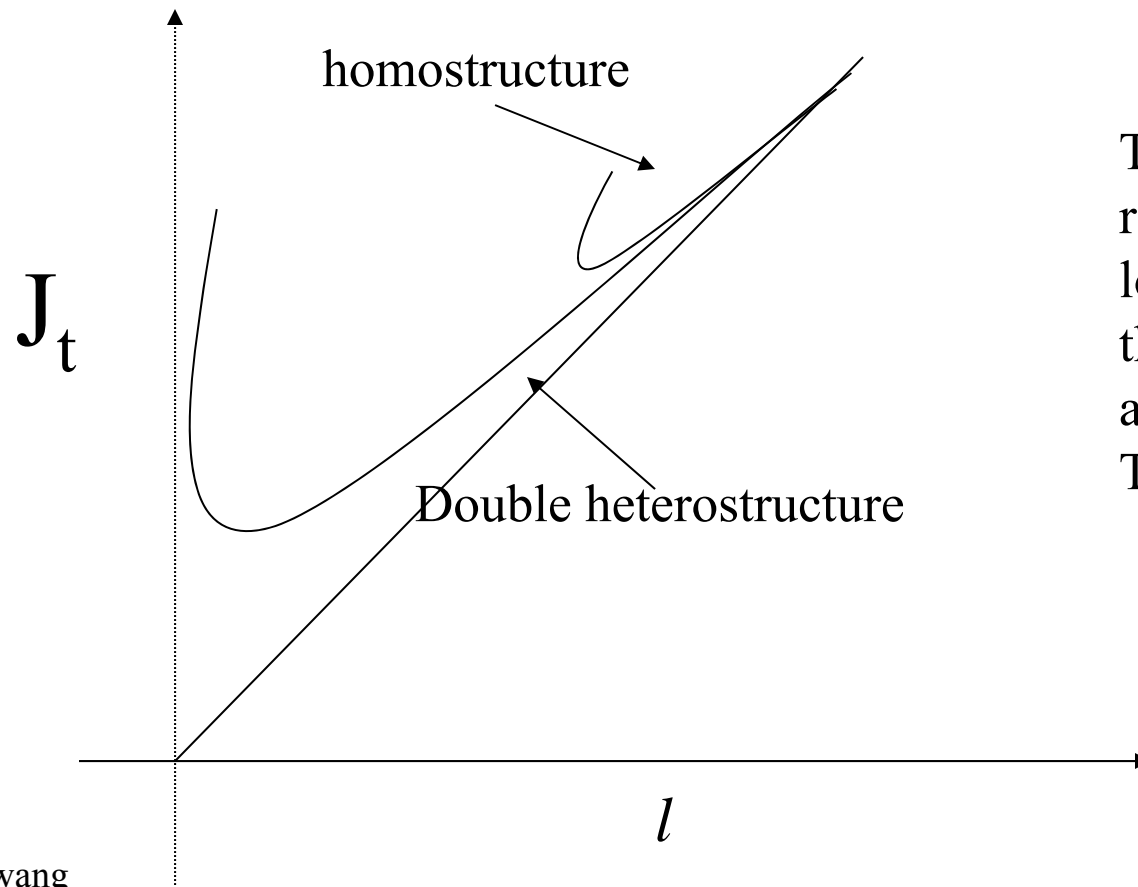

The confinement factor remains near 1 for lower values l because the active layer behaves as an optical waveguide. The result is a lower J_t .

Internal Photon Flux

When laser current density is increased above its threshold value ($J > J_t$), the amplifier peak gain γ_p exceeds loss coefficient α_r . Stimulated emission then outweighs absorption and other Resonator losses so oscillation begin and the photon flux increases

$$\Phi = \eta_{\text{int}} (i - i_t) / e \quad , \quad i > i_t \text{ (steady-state laser internal photon flux)}$$
$$= 0 \quad , \quad i \leq i_t$$

Photons per second generated within the active region

The internal laser power above threshold is simply related to the internal photon flux by $P = h\nu \Phi$
So we have

$$P = 1.24 \eta_{\text{int}} (i - i_t) / \lambda_o$$

Output Flux and Efficiency

The output flux is the product of internal flux and emission efficiency, which is the ratio of the loss associated with the useful light transmitted through the mirrors to the total resonator loss $\eta_e = \alpha_m / \alpha_r = \alpha_{m1} + \alpha_{m2} = [(1/2d)\ln(1/R_1R_2)]/\alpha$

$$\Phi_{out} = \eta_e \eta_{int} (i - i_t) / e$$

The laser output power above threshold is

$$P_{out} = 1.24 \eta_d (i - i_t) / \lambda_o, \quad \eta_d = \eta_e \eta_{in} \text{ (differential quantum efficiency)}$$

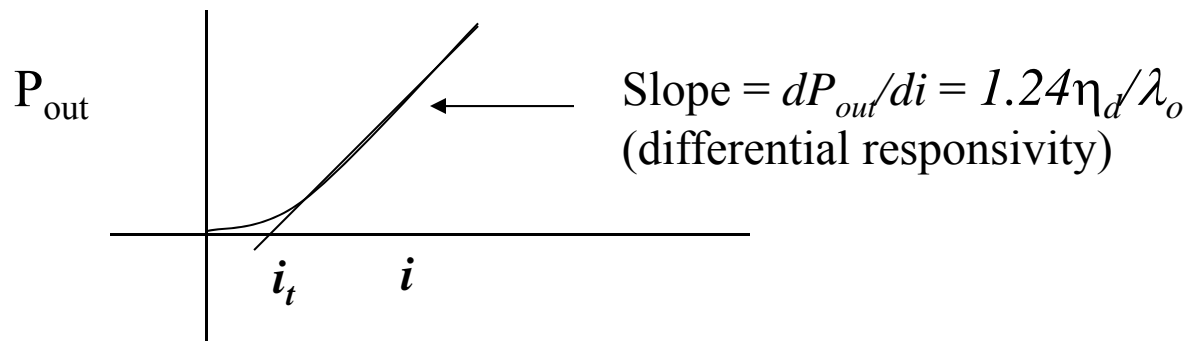

Output Characteristics

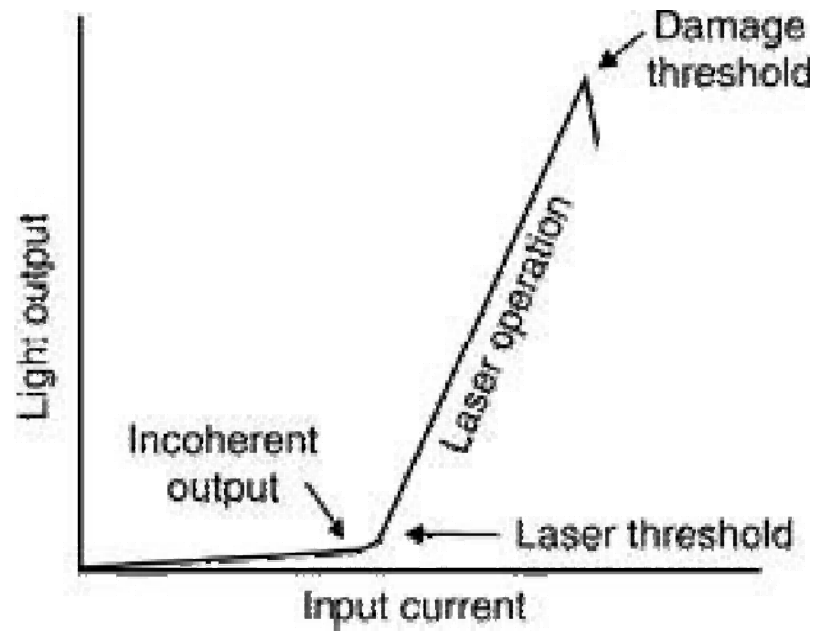

At low values of the input, the device acts as a light-emitting diode (LED), producing a relatively small amount of incoherent light.

At a threshold value, where the population inversion is large enough so that gain by stimulated emission can overcome the losses, the laser threshold is reached. As current increases above the threshold value, the light output increases much more rapidly than in the LED region.

Overall Efficiency

The overall efficiency (Power-conversion efficiency) is defined as the ratio of the emitted laser light power to the power to the electrical input power iV

$$\eta = \eta_d(1-(i_f/I))hv/eV$$

Temperature Dependence of Laser Output

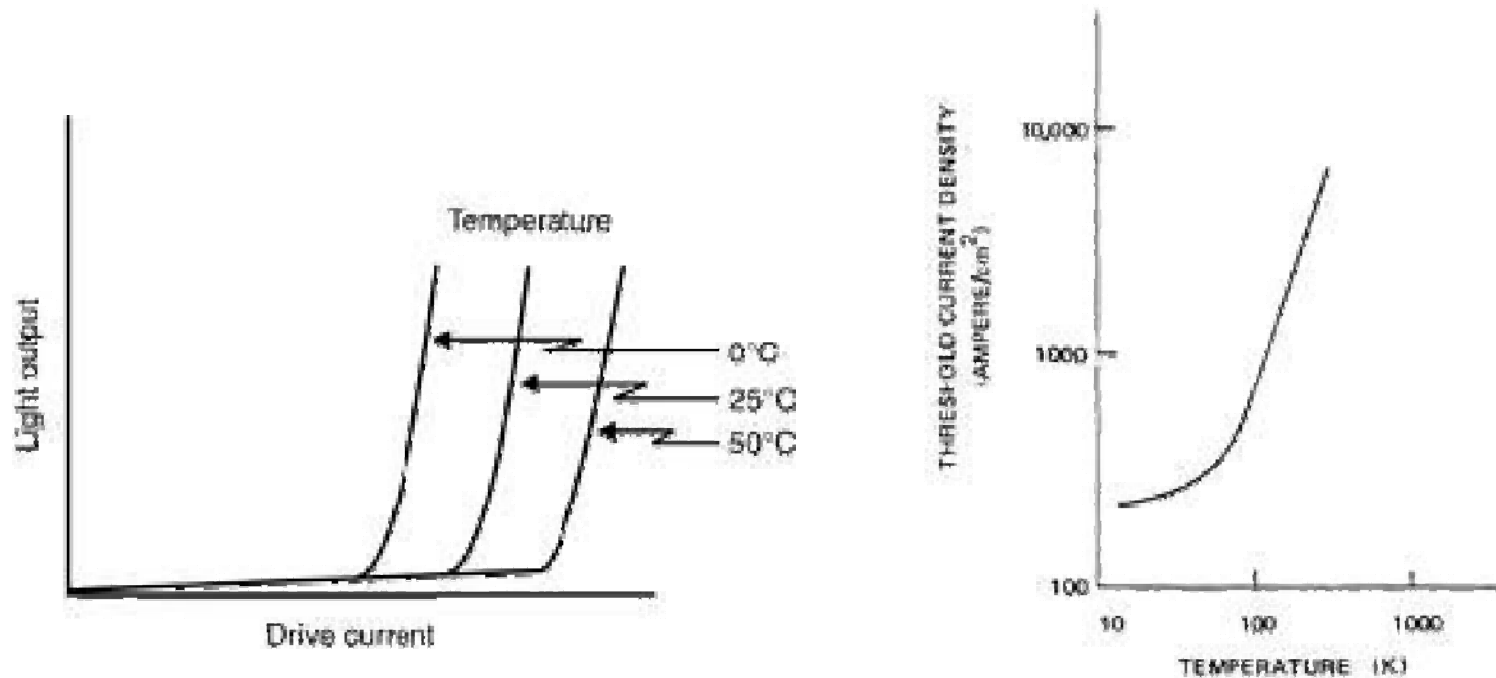

a) Schematic sketch of the output of a typical laser diode as a function of drive current for three different operating temperatures. b) Temperature dependence of threshold current.

w.wang

Wavelength as a function of Temperature

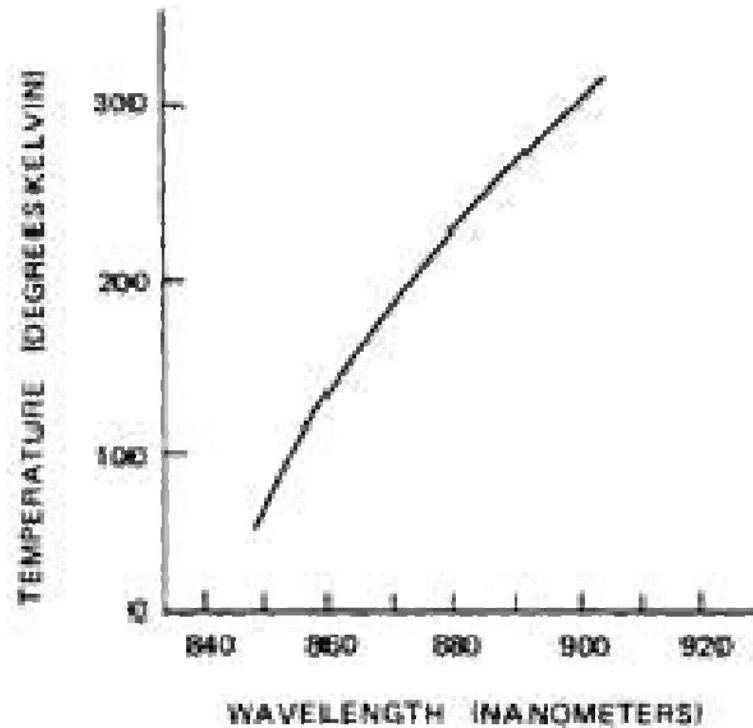

Gallium arsenide lasers emit radiation in the near infrared portion of the spectrum. The exact wavelength depends on the temperature at which the laser is operated.

Cooling of Laser Diodes

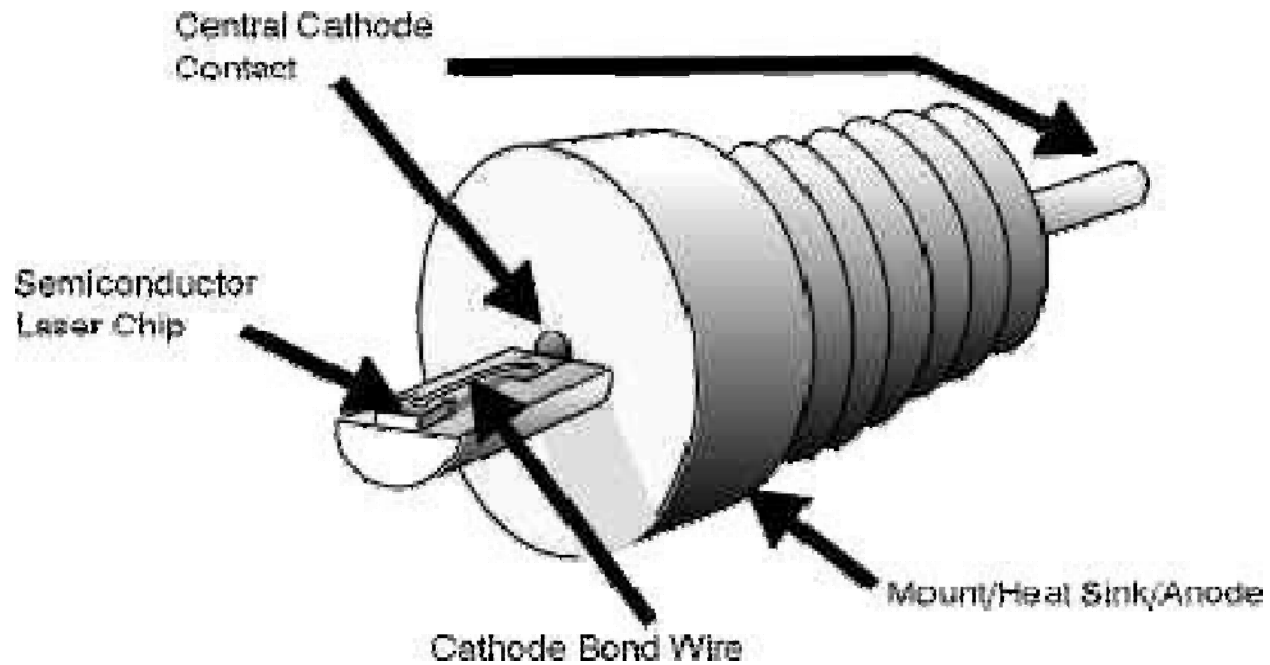

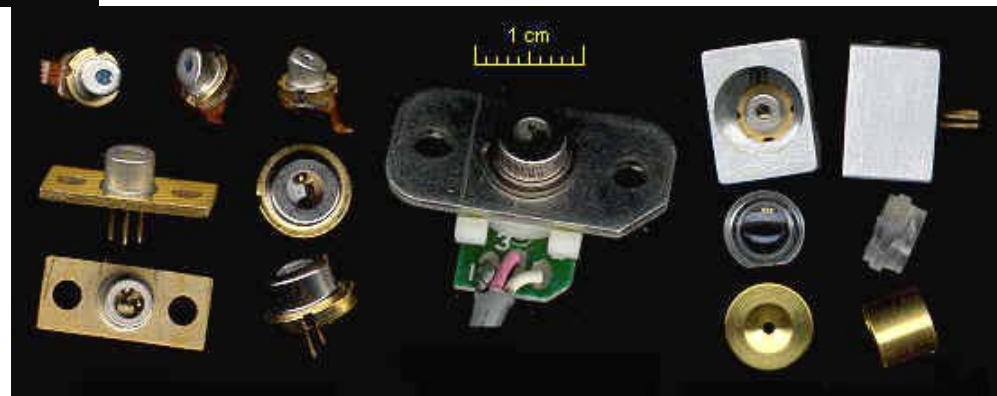
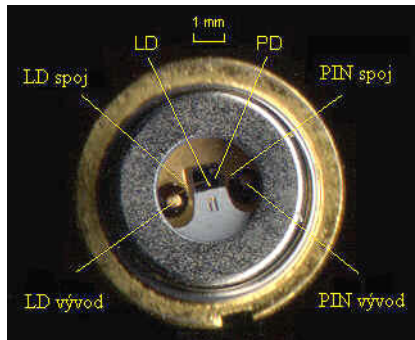

Infineon Technologies, Agilent Technologies, Hitachi, Intelite, Laser Components Instrument Group, Alcatel, Furukawa Electrics, Mitsubishi

Spectral Characteristics

The spectral distribution is governed by three factors

1. Spectral width B within which the active medium small signal gain is greater the loss coefficient α_r
2. Homogeneous and inhomogeneous nature of the line-broadening mechanism
3. Resonant modes $\nu_f = C / 2nd$

Spectral Characteristics

When the threshold current density is exceeded, the emission spectrum narrows dramatically and the intensity of the emission increases considerably. Figure shows the emission spectrum of a laser diode below and also above threshold. At higher currents the linewidth of the laser output decreases.

The width of the spectral band represented by the spontaneous emission is much greater than that of the stimulated emission. However, stimulated emission produced by the laser is still much broader than that of conventional gas and crystalline lasers. It is of the order of two or three nanometers, as compared to a typical spectral width around 10^{-3} nanometers for a HeNe laser.

The emission spectrum is relatively complex and typically contains a number of longitudinal modes of the optical cavity. The spacing between longitudinal modes is relatively large, because of the short length of the optical cavity. However, the relatively large spectral width of the GaAs laser allows several modes to be present.

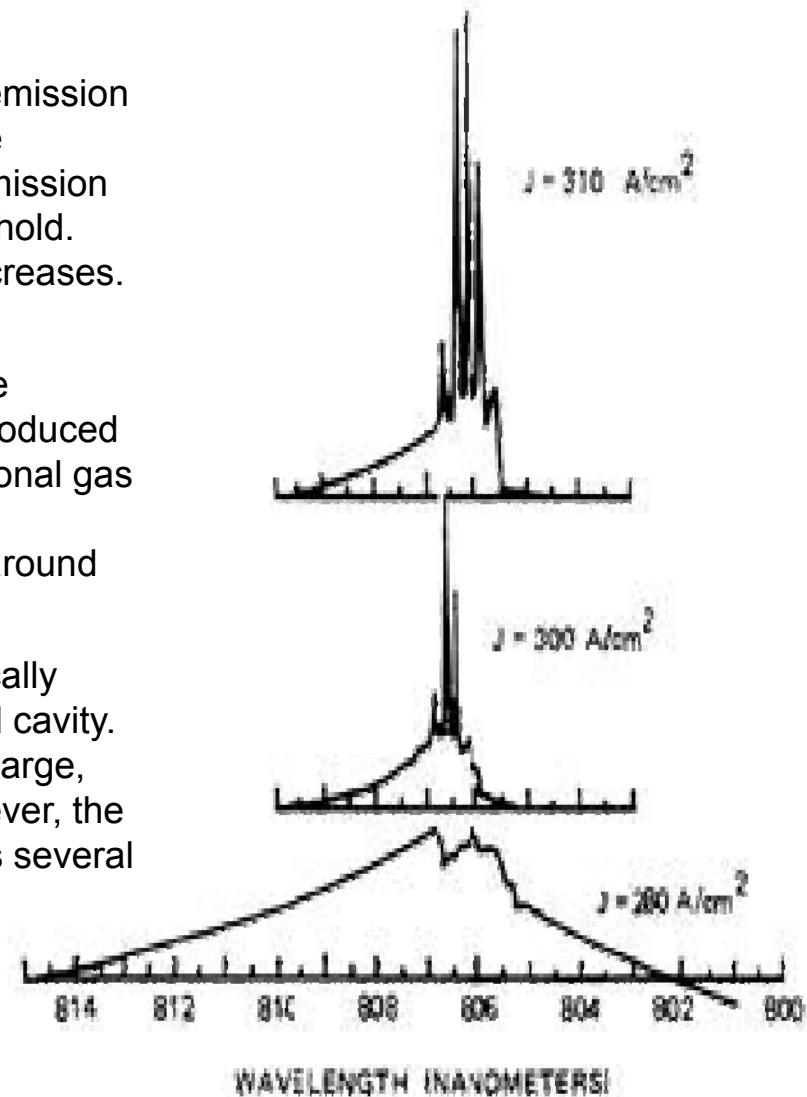

Far-Field Radiation Pattern

A laser diode with an active dimension l and w emits Light with far field angular divergence $\sim \lambda_0/l$ in the Plane perpendicular to the junction and λ_0/w in the Plane parallel to the junction.

Assume Gaussian beam of diameter $2W_0$, the divergence angle is $\theta = (2\pi)(\lambda_0/2W_0)$

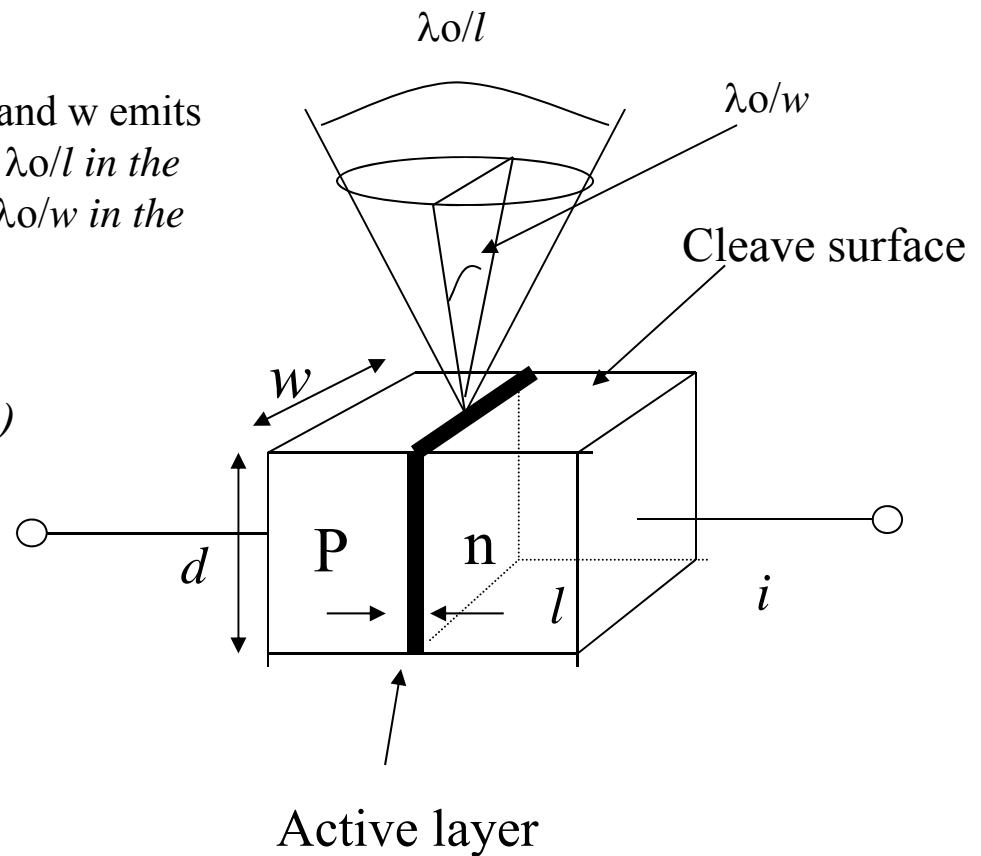

Spatial Characteristics

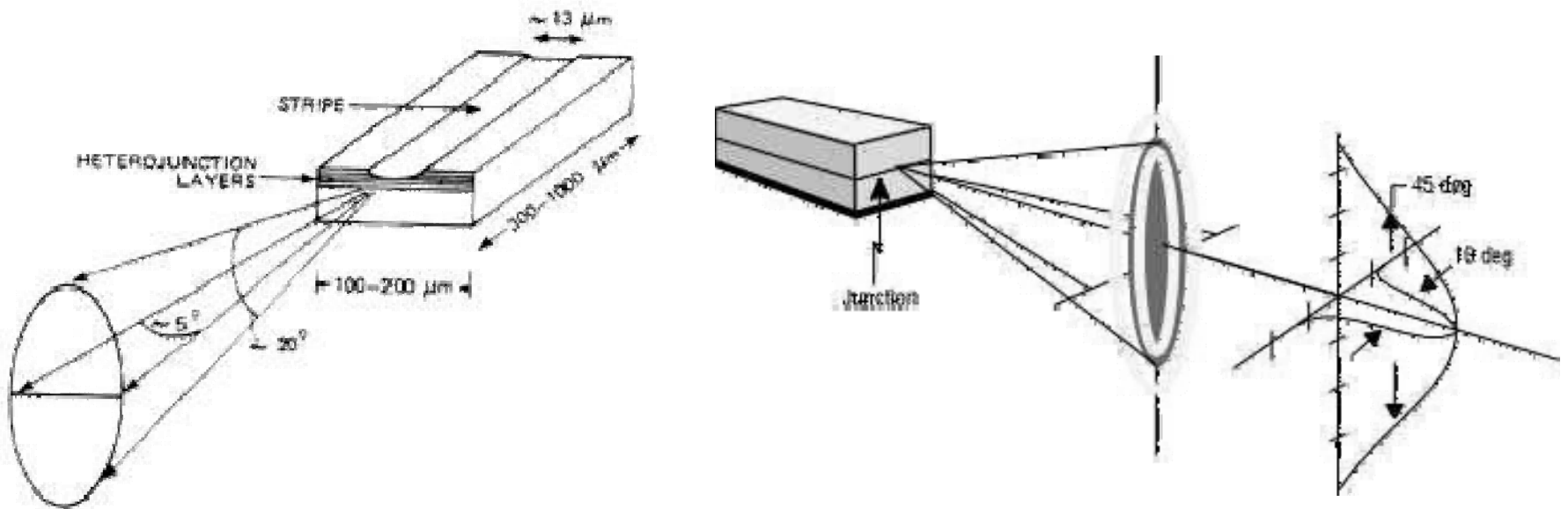

A semiconductor laser typically has an elliptical spatial profile

The profile is caused by diffraction. Light is emitted through the aperture defined by the small junction. Diffraction through the narrow dimensions of the junction causes the beam to spread into a broader angle than is observed with other types of lasers.

Laser Lifetime

Two different types of failure mechanisms have been identified in gallium arsenide lasers. One is a catastrophic decrease in the power output. This catastrophic damage may occur within a single pulse of the laser, and it is associated with damage of the end surfaces of the laser. The damage is produced by the light output of the laser itself. Tiny cracks or grooves in the junction are produced. To avoid this type of damage, peak power output of the laser must be limited.

There is also a gradual increase in power, which is manifested by increasing threshold current. This damage is produced by the current flowing through the junction. This is a complex phenomenon that is complicated by random variations in the laser life. To extend the life of the laser diode, current density through the junction should be limited.

Other Types of Semiconductor Lasers

Material	Wavelength (μm)	Material	Wavelength (μm)
ZnS	0.33	GaAs	0.84-0.95
ZnO	0.37	InP	0.91
Gan	0.40	GaSb	1.55
ZnSe	0.46	InAs	3.1
CdS	0.49	Te	3.72
ZnTe	0.53	PbS	4.3
GaSe	0.59	InSb	5.2
CdSe	0.675	PbTe	6.5
CdTe	0.785	PbSe	8.5

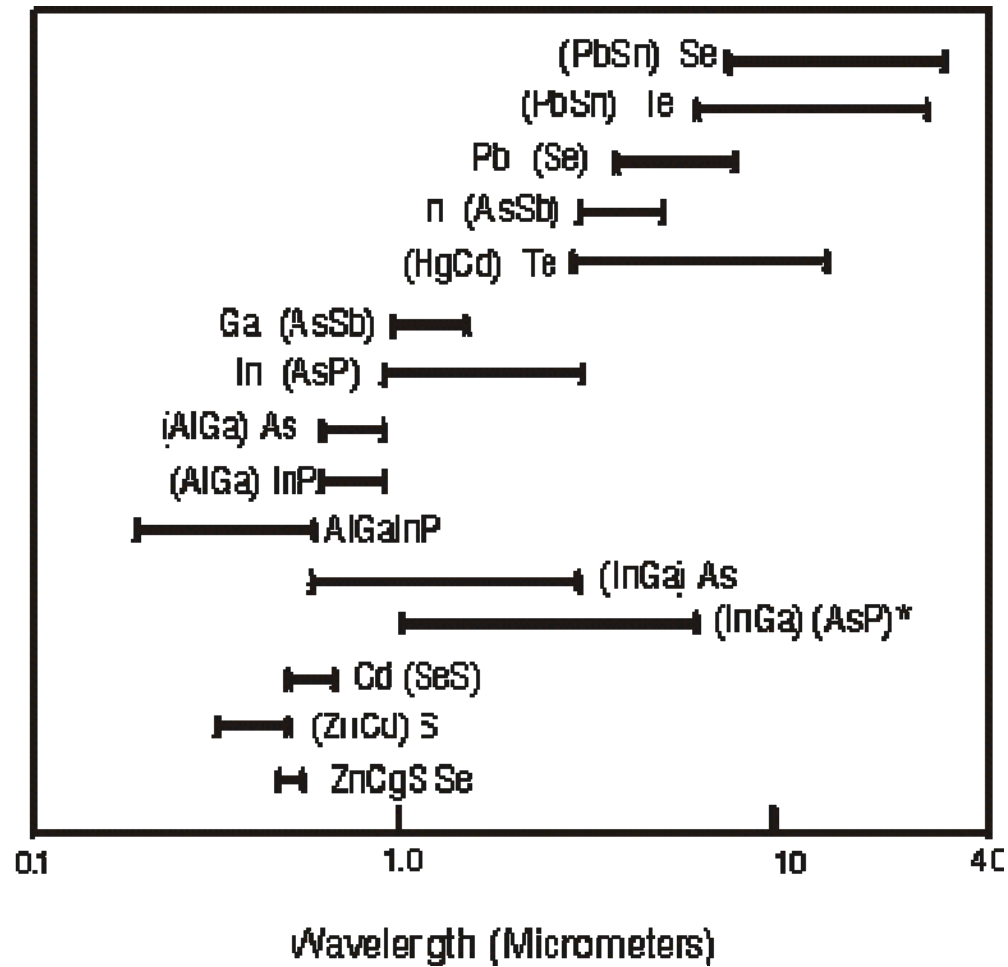

Wavelength ranges covered by a number of semiconductor lasers of mixed composition
w.wang

Distributed-feedback (DFB) laser

Grating limits emission to one frequency.

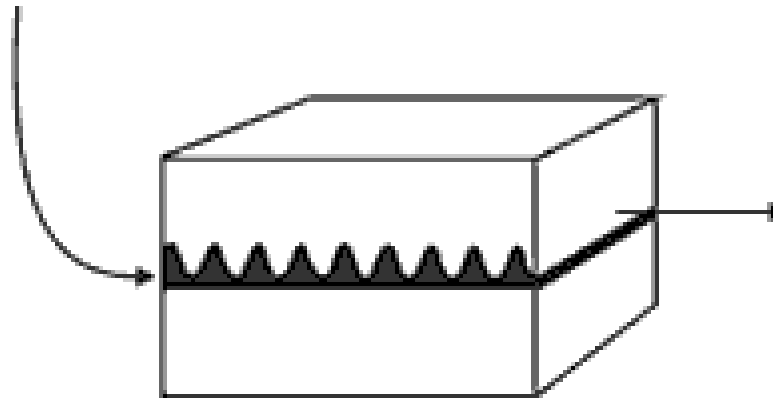

With introduction of a corrugated structure into the cavity of the laser, only light of a very specific wavelength is diffracted and allowed to oscillate.

Packaging

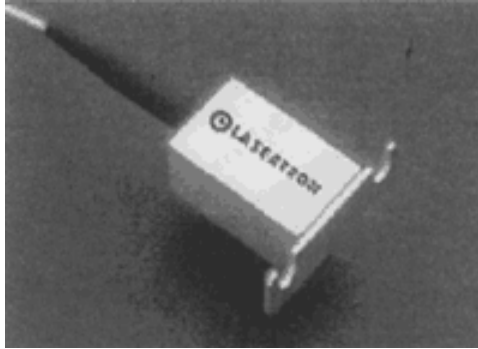

14-pin DIL package (Courtesy of Lasertron)

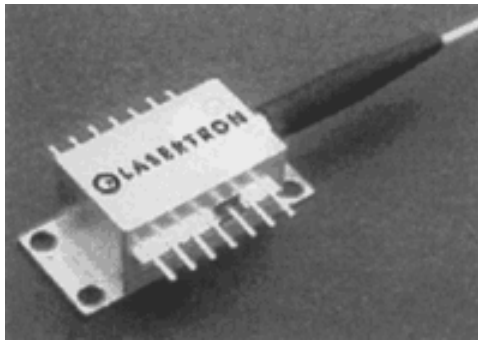

1550-nm DFB laser in butterfly package (Courtesy of Lasertron)

Laser fiber coupling

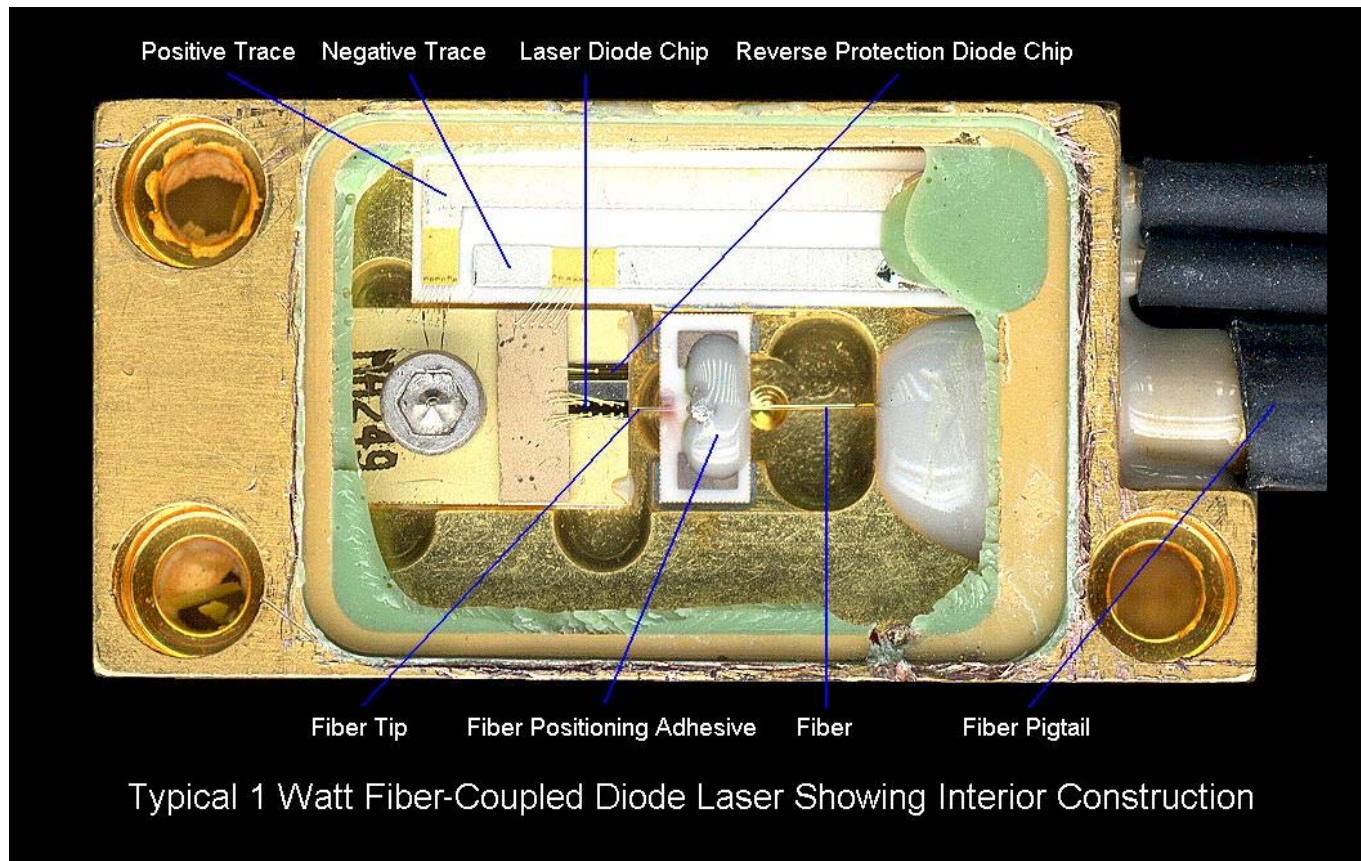

Laser applications

Industrial applications: engraving, cutting, scribing, drilling, tooling, welding, etc.

Medical applications: cutting, soldering, correct vision
**diagnostics of cancer cells using fluorescence,
and photo dynamic therapy , remove unwanted tissue,
photothermal, etc.**

Micromachining: 3-D micromachining, etching, engraving, etc.

Characteristics of Several Industrial Lasers

LASER	POWER RANGE (W)	WAVE-LENGTH (m)	TYPICAL INDUSTRIAL APPLICATIONS
CO ₂ – Flowing Gas (Continuous Wave and Pulsed)	500 – 45,000	10.6	Cutting, welding, cladding, free forming, and hardening
CO ₂ – Sealed (Pulsed)	10 – 1,000	10.6	Micro-welding, cutting, scribing, and drilling
Nd:YAG (Continuous Wave)	1,000 – 5,000	1.06	Welding, cutting, cladding, and hardening
Nd:YAG (Pulsed)	10 – 2,000	0.53 - 1.06	Micro-welding, cutting, drilling, scribing, and marking
Nd:YAG –Diode Pumped (Pulsed)	10 - 500	1.06	Cutting, drilling, scribing, marking, and micro-machining.
Excimer (Pulsed)	0.001 - 400	0.157 – 0.351	Micro-machining, marking, and photolithography

w.wang

"Laser Applications and Processing in Precision Manufacturing" was help at the EOC on December 7, 2000

Laser Wavelengths

- **Each type of laser has a characteristic wavelength of the output beam**
- **The particular wavelength of the laser has several ramifications on processing:**
 - **lower wavelengths, typically, have better absorption in metallic materials**
 - **however, lower wavelengths also allow the transmission through fiber optics**
 - **lower wavelengths also provide smaller focused spots**

Beam Delivery Systems for Laser Processing

Hard Optic Delivery (CO₂, Nd:YAG, and Excimer Lasers)

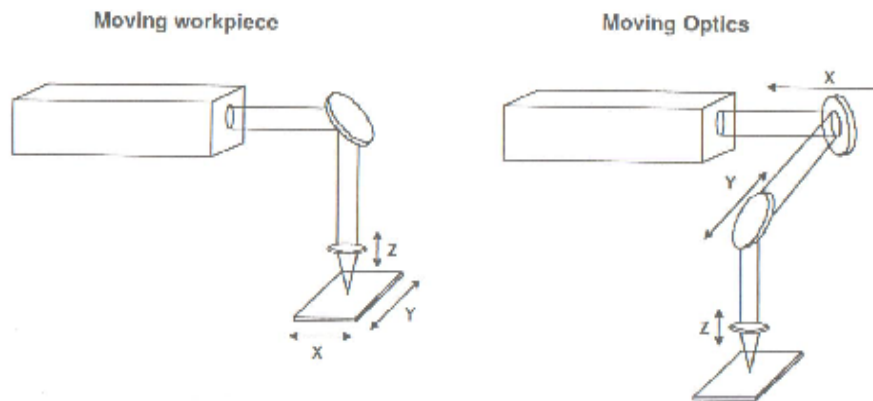

- Mirrors must be properly aligned and clean
- Can be used with practically any wavelength
- Hard optical systems are fairly reliable

Fiber Optic Delivery (Primarily Nd:YAG Lasers)

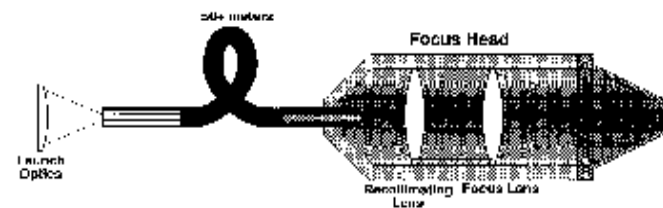

- Versatile delivery to workstation
- No practical fiber materials for use with CO₂ lasers (10.6 μm radiation)
- Requires high fiber bend radius (approx. 0.2 m) to prevent leakage
- Destroys coherency of beam, resulting in larger focal spot

w.wang

"Laser Applications and Processing in Precision Manufacturing" was help at the EOC on December 7, 2000

There are major performance differences between Nd:YAG and CO2 lasers. One reason is that Nd:YAG light is emitted at a wavelength of 1.06 microns in the near infrared, while CO2 light is emitted at 10.6 microns. The material interactions at these wavelengths differ. Most organics don't absorb 1 micron light very well, while they absorb 10 micron light. So, non-metal processing is generally a CO2 application. Metals are more reflective at 10 microns than at 1 micron, so CO2 lasers only weld effectively in the "keyhole" mode, where the irradiance is high enough to generate a vapor channel in the workpiece. Once you get into keyhole mode, the high average power of CO2 lasers makes high speed welding possible. For small spot welds, Nd:YAG lasers are far more controllable.

Also, since there are a lot more Nd atoms in a YAG rod than there are CO2 atoms in laser gas, Nd:YAG lasers can deliver much higher peak powers than CO2 lasers. This makes them better for drilling. Conversely, since it's hard to cool a solid rod, Nd:YAG lasers have problems with high average powers. You can build a CO2 laser with very high power; Convergent has commercial 45 kW units, and much bigger ones have been built.

Components of a Laser Processing System

- The application of lasers in industry cover a wide range of processes (to name a few):

- welding, brazing, and soldering,
- cutting and drilling
- scribing and marking
- micro-maching
- near net shape processing

- Typically, a particular laser is chosen to optimize the process

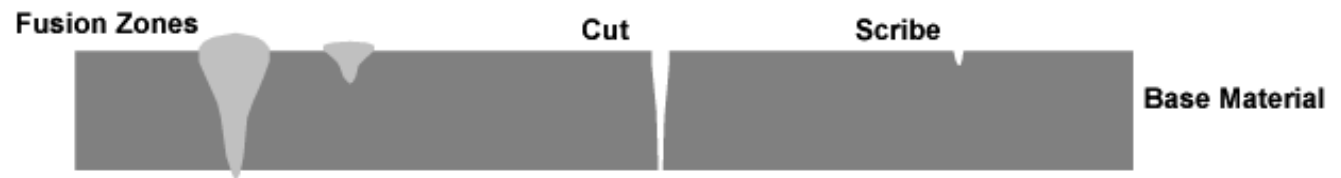
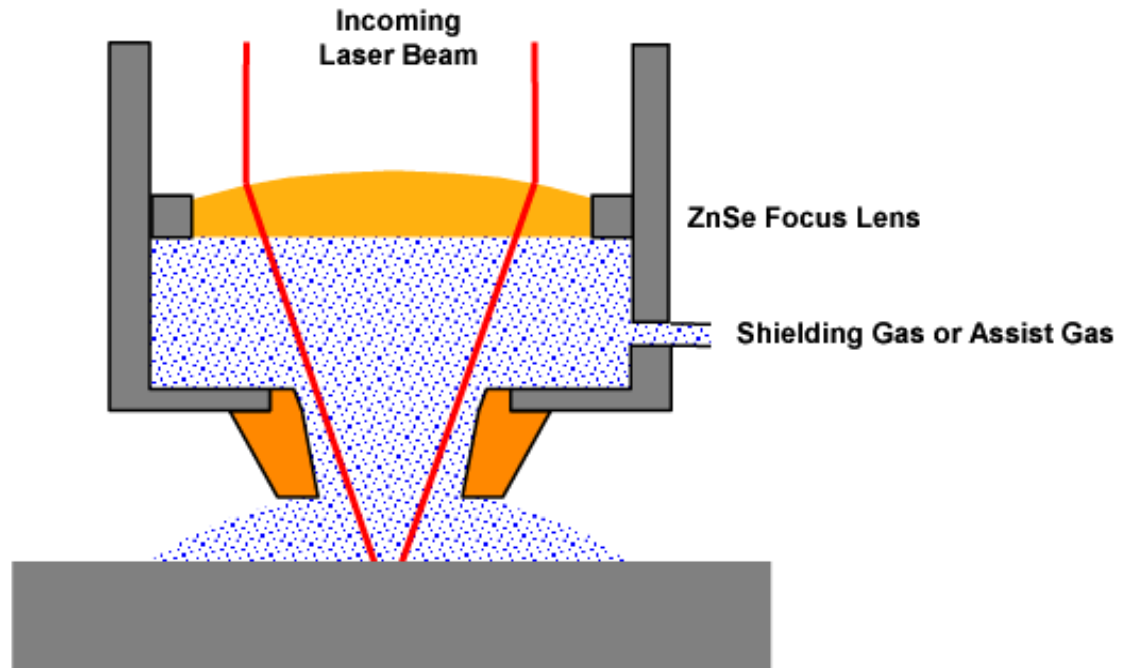

w.wang

"Laser Applications and Processing in Precision Manufacturing" was help at the EOC on December 7, 2000

Examples of Laser Cutting with a Pulsed CO₂ Laser



w.wang

Photo courtesy of PRC Laser

Precision Soldering of Electronic Components Using a Nd:YAG Laser

Laser Soldered Component

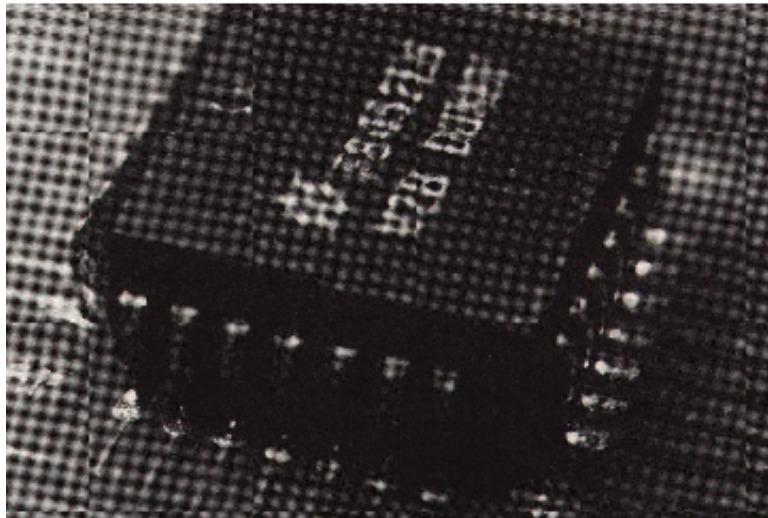

Laser Soldered Joint Showing Wetting



Micro-machining with Excimer Laser and Image Projection

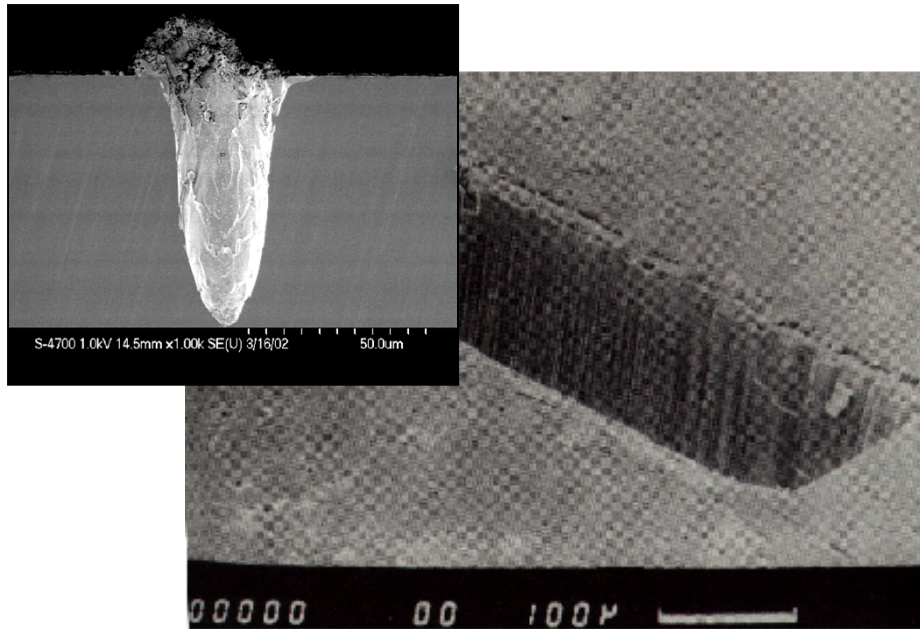

100 μm wide slot in borosilicate glass using image projection and 20X demagnification and excimer laser (ArF at 193 nm)

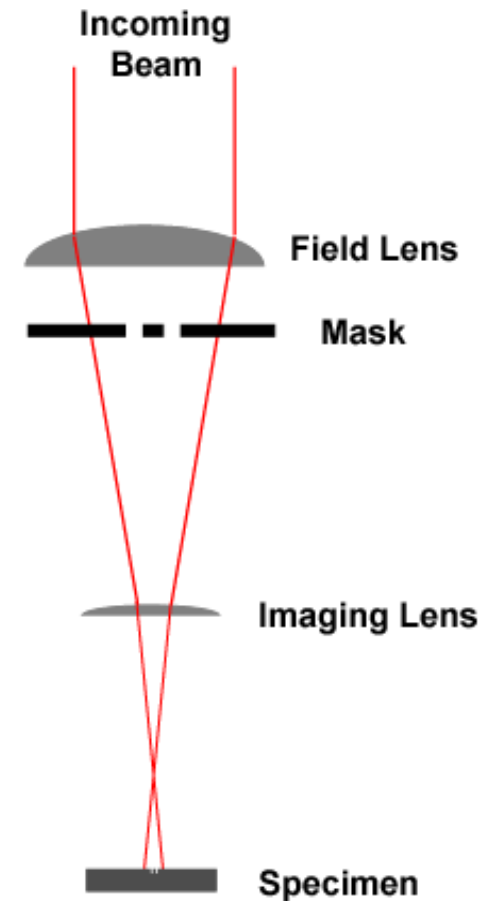

w.wang

"Laser Applications and Processing in Precision Manufacturing" was help at the EOC on December 7, 2000

Lasers in General Surgery

Almost every medical surgery in which a removal of tissue is required, or a cut needs to be made, can be done with a laser. In general, the results using lasers are better than the results using a surgical knife.

- When a **bleeding need to be stopped**, a Nd-YAG laser can be used. Its radiation enters deep into the tissue, and heats and coagulates a large area.
- When a **clean cut** need to be done, an Excimer laser is used.
- A more **general cutting tool** is the CO₂ laser.

Lasers in Dentistry

Dental soft tissue treatment applications are similar to those of other soft tissue in the body, and are common for many years.

- In case of **gum surgery**, with the laser most of the patients suffer less postoperative pain.
- Almost no bleeding.
- No stitches required.

Dental hard tissue treatment is new, and only in May 1997 the **FDA (Federal Drug Administration)** approved the Er-YAG laser for use on the hard tissue (teeth) in humans.

Examples of Laser used in Dentistry

Argon: laser teeth whitening

Dual Wavelength Surgical Argon: teeth whitening; soft tissue surgeries, such as gingivoplasty, frenectomy and biopsy; composite curing, which reinforces and strengthens the tooth

Nd:YAG: soft tissue surgery, such as gingivoplasty, frenectomy, gingivectomy, bacteria reduction when treating gum disease

Er:YAG: removal of tooth decay/cavities while also decontaminating the area, frenectomy, crown lengthening

Perio Diode: gum treatment and soft tissue surgery, such as gingivoplasty

Low Level Laser Therapy (LLLT): biophotomodulation, treats canker sores, herpes, sore jaws, helps relieve post-op discomfort and promotes post-op healing

Diagnodent Laser: early detection of cavities

Lasers for eye treatment

Soldering Detached Retina

As a result of mechanical shock, the retina inside the eye can be torn, and detached from the tissue it is connected to

The electromagnetic radiation from the laser heats the detached retina, and as a result the damaged blood vessels around the retina are closed and solder to place.

Because of the **focusing effect of the eye**, small amount of laser power is needed to solder the detached retina.

Excimer laser

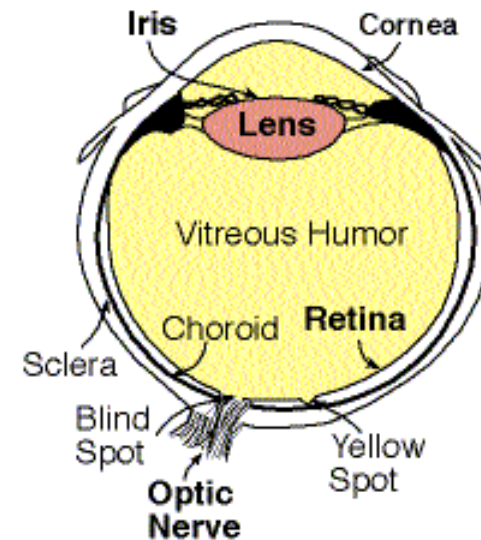

Rami Arieli: "The Laser Adventure" Chapter 9.2.1 Eye page 1

Lasers in Diagnostic Medicine, and in combination with Drugs

Diagnostics of cancer cells using Fluorescence, and Photo Dynamic Therapy (PDT)

One of the biggest problems in medicine today is to find a **cure for cancer**.

There are **many treatments for cancer to destroy the cancer cells**, such as:

- Disectomy of the infected organ.
- Radioactive irradiation.
- Heat treatment.

Types of Lasers

Although there are several different kinds of lasers, only three kinds have gained wide use in medicine:

Carbon dioxide (CO₂) laser—This type of laser can remove thin layers from the skin's surface without penetrating the deeper layers. This technique is particularly useful in treating tumors that have not spread deep into the skin and certain [precancerous](#) conditions. As an alternative to traditional scalpel [surgery](#), the CO₂ laser is also able to cut the skin. The laser is used in this way to remove skin cancers.

Neodymium:[yttrium](#)-aluminum-garnet (Nd:YAG) laser—Light from this laser can penetrate deeper into tissue than light from the other types of lasers, and it can cause [blood](#) to clot quickly. It can be carried through optical [fibers](#) to less accessible parts of the body. This type of laser is sometimes used to treat throat cancers.

Argon laser—This laser can pass through only [superficial](#) layers of tissue and is therefore useful in dermatology and in eye surgery. It also is used with light-sensitive dyes to treat tumors in a procedure known as [photodynamic therapy](#) (PDT).

Soft lasers

Most of the medical laser applications were until recently based on the **thermal effects** caused by the electromagnetic radiation which was absorbed in the biological tissue.

In the last few years, some new applications are using low power **lasers with output power less than 1 Watt.**

Some of the effects of these low power levels on the biological tissue is not thermal, and in effect **the mechanism of interaction is not yet clear.**

It is sometimes referred to as **Biostimulation**, which does not explain a lot.

Lasers in Dermatology

Among these defects are:

- **Pigmented skin, Abnormal skin growth, Blemishes.**

- **Tattoos.** Today, with the wide variety of lasers in use, tattoos can almost completely be erased from the skin. Different wavelengths are used to remove different ink colors from the skin. The specific laser wavelength is **selectively absorbed by the specific color, without damage to surrounding cells.** Usually the treatment is made in a number of treatments. After each treatment checking what was left in the damaged skin. (Ruby and Nd: YAG laser)

A nice Web site about the laser tattoo removal is at **Beckman Laser Institute and Medical Clinic:**

<http://www.bli.uci.edu/clinic/tattoos.html>

- **Carcinomas and malignancies.**

Rami Arieli: "The Laser Adventure" Chapter 9.2.1 Dermatology page 1

This is an example of a laser system for hair removal procedures.

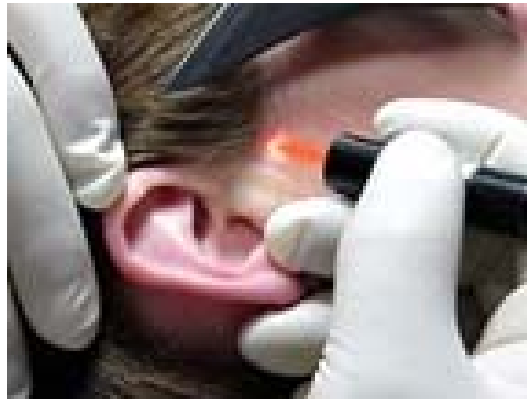

Emitting wavelength	<i>(810 ± 10) nm</i>	Classification: IIIb
Output power	<i>User-adjustable 0 to 15 Joules</i>	Designation: OEM
Generation modes	<i>CW</i>	Manufacturer: LaserTec, UK
Beam characteristic	<i>Semiconductor Diode</i>	Warranty: 1 Year
Pulse duration	<i>Manual Adjust</i>	Emission Indicator: Yes
Weight	<i>1.2 kg max</i>	Key Lock: Yes
Optics	<i>Pinpoint 2mm</i>	Beam Shutter: No
Dimensions	<i>10 x 19 x 7.5 inches</i>	21CFR 1040, IEC 825-1:1993: No

Diode laser arrays

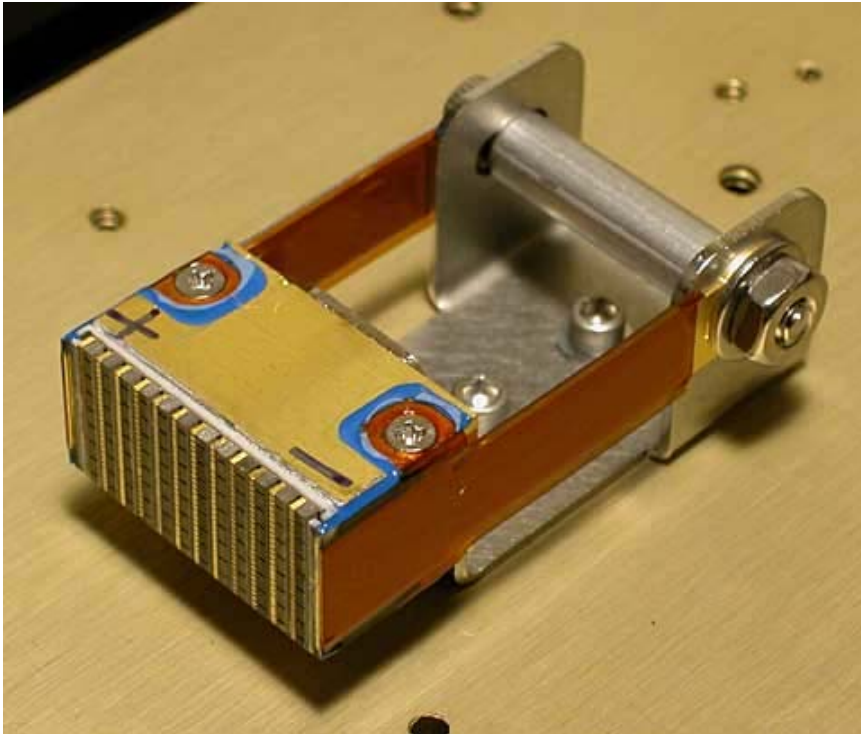

Courtesy E-Bay

Specifications

- Emitting Dimensions: 10 x 17.2mm
- CW Output Power: 240W
- Threshold Current: 7A
- Operating Current: 25A typ, 30A max
- Operating Voltage: 22.8V typ, 25.8V max
- Series Resistance: 0.19 ohm
- Beam Divergence: 35 x 10 degrees
- Peak Wavelength: 803nm
- Spectral Width: 3nm typ, 4nm max

Cooling Requirements

- Flow: 1.5 LPM
- Pressure: 15 PSI
- Water Temperature: 25C
- DI Water not required
- <20um particle filter required

laser diode bar array made by Spectra Diode Labs (SDL). This is model 3474-MB. It consists of 12 20W diode bars in a 10 x 20mm G stack package producing an amazing 240W with an energy density of $120\text{W}/\text{cm}^2$.

A diode laser bar

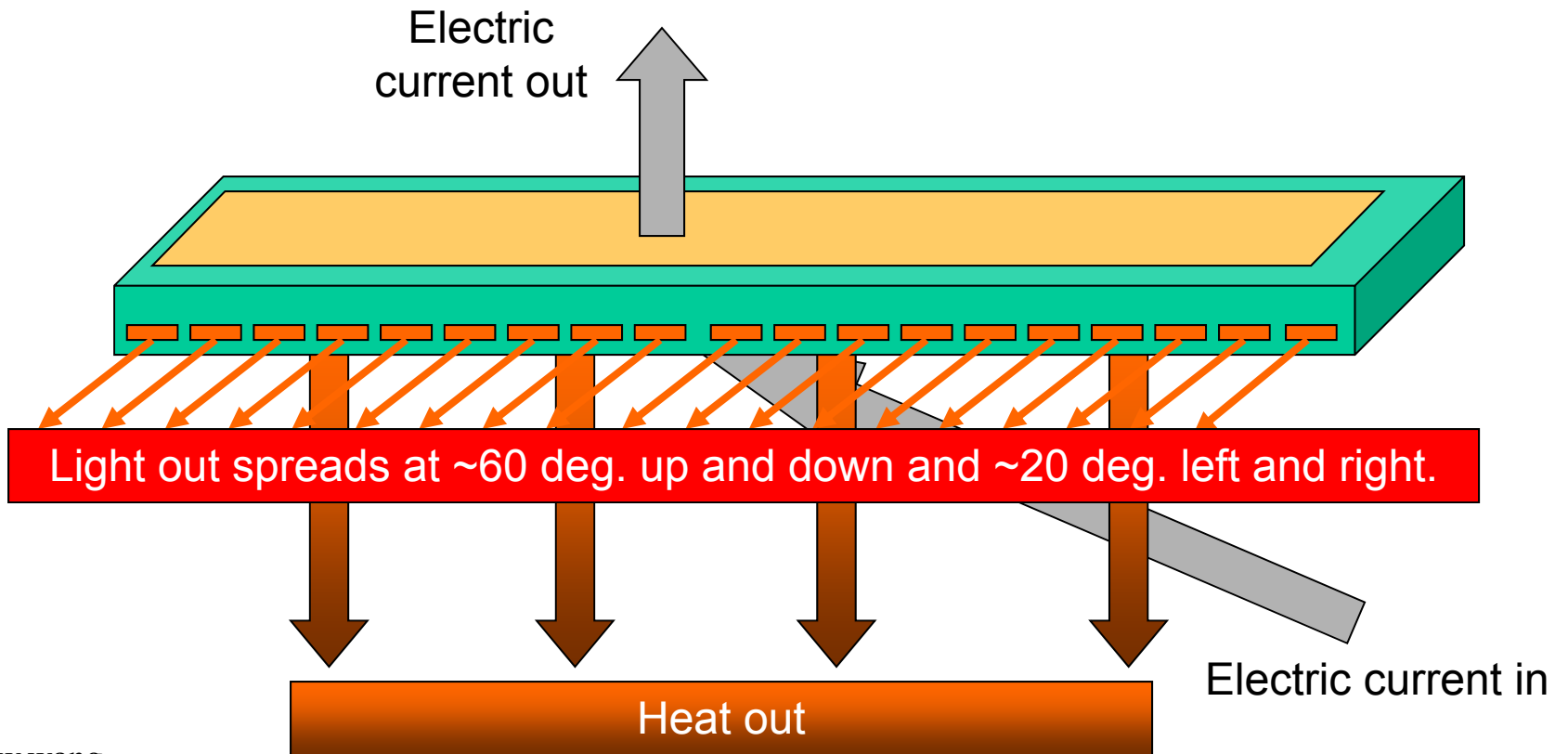

A diode laser array pumped solid state laser

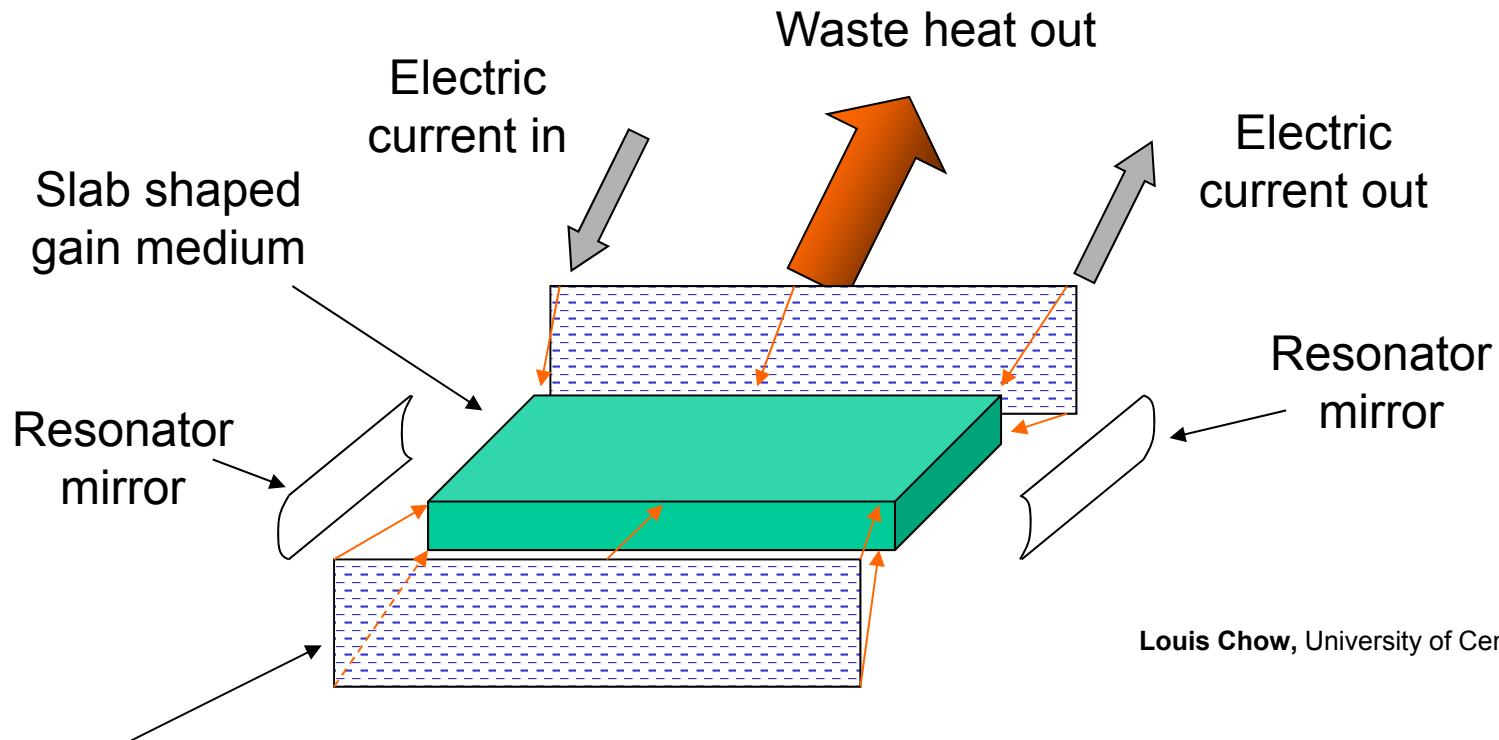

Louis Chow, University of Central Florida

Diode laser arrays (2) with beam control prisms
w.wang pumping a slab laser through both mid sized edges

Fiber Optic Sources

Two basic light sources are used for fiber optics: lasers and light-emitting diodes (LED). Each device has its own advantages and disadvantages as listed in Table

Characteristic	LED	Laser
Output power	Lower	Higher
Spectral width	Wider	Narrower
Numerical aperture	Larger	Smaller
Speed	Slower	Faster
Cost	Less	More
Ease of operation	Easier	More difficult

Output Power	Linearly proportional to drive current	Proportional to current above the threshold
Current	Drive Current: 50 to 100 mA Peak	Threshold Current: 5 to 40 mA
Coupled Power	Moderate	High
Speed	Slower	Faster
Output Pattern	Higher	Lower
Bandwidth	Moderate	High
Wavelengths Available	0.66 to 1.65 μm	0.78 to 1.65 μm
Spectral Width	Wider (40-190 nm FWHM)	Narrower (0.00001 nm to 10 nm FWHM)
Fiber Type	Multimode Only	SM, MM
Ease of Use	Easier	Harder
Lifetime	Longer	Long
Cost	Low (\$5-\$300)	High (\$100-\$10,000)

w.wang

w.wang