

PHYS 575

Autumn 2015

# Radiation and Radiation Detectors

Course home page:

<http://depts.washington.edu/phycert/radcert/575website/>

**5: cross sections, attenuation; calorimetry;  
counting statistics; statistics for analysis**

R. Jeffrey Wilkes

Department of Physics

B305 Physics-Astronomy Building

206-543-4232

[wilkes@u.washington.edu](mailto:wilkes@u.washington.edu)

# Course calendar

week	date	day	topic	text
1	10/1/15	Thurs	Introduction, review of basics, radioactivity, units for radiation and dosimetry	Ch. 1, notes
2	10/6/15	Tues	Radioactive sources; decay processes;	Ch. 1, notes
3	10/13/15	Tues	Photomultiplier tubes and scintillation counters; Counting statistics	Chs. 3, 8, 9 (I-V)
3	10/15/15	Thurs	<b>LAB: Room B248</b> Scopes, fast pulses; PMTs and scintillation counters; standard electronics modules	Chs. 4, 9, 16, 17
4	10/20/15	Tues	Overview of charged particle detectors	Ch. 4
4	10/22/15	Thurs	<b>LAB: Room B248</b> Coincidence techniques; nanosec time measurement, energy from pulse area	Chs. 17, 18
5	10/27/15	Tues	Interaction of charged particles and photons with matter; counting statistics; gas detectors; <b>Proposal for term paper must be emailed to JW by today</b>	Chs. 2, 3; Chs. 5, 6, 7
6	11/3/15	Tues	ionization chambers; solid-state detectors	Chs. 11, 12, 13
7	11/10/15	Tues	Detecting neutral particles; Data acquisition methods	Ch. 14, 15, 18
8	11/17/15	Tues	Cherenkov detectors; Case studies: neutrino detectors (IceCube), atmospheric Cherenkov, triggering Cherenkov	Ch. 19, notes
9	11/24/15	Tues	Case studies: classic detectors (cloud and bubble chambers, nuclear emulsion), high energy accelerators, Fermi LAT	Ch. 19, notes
10	12/1/15	Tues	Finish case studies; begin student presentations	Notes
11	12/8/15	Tues	Student presentations	-
11	12/10/15	Thurs	Student presentations	

Tonight →

# Announcements

- All but 2 have sent me proposed topics
- Presentation dates: Tues Dec 1, Tues Dec 8, and Thurs Dec 10
  - See class web page for link to signup sheet
- **NEW** [Schedule and signup table](#) for term project presentations. This is a Google spreadsheet in the UW Google Docs filespace; log in with your UW NetID username and password (NOT your personal Google username) for access. Sign in to the slot you want, then exit, and let me know you did so by email.

I will arbitrarily assign slots for those not signed up by November 29

As of today:

PHYS 575 Au-15: Report Presentations			
Please send me your presentation ppt/pdf (or URL) at least 1 hour before class on your date			
Day	Time	Name	Topic
12/1/2015	7:00 PM	Per Provencher	Low Background Laboratories
	7:20 PM	Rick McGann	Neutron Generation and Effects on Materials and Electronics
	7:40 PM	Chris Provencher	Bremsstrahlung
	8:00 PM		
12/8/2015	8:20 PM		
	6:40 PM	Diana Thompson	NORM
	7:00 PM		
	7:20 PM		
	7:40 PM		
12/10/2015	8:00 PM		
	8:20 PM		
	6:40 PM		
	7:00 PM	Farrah Tan	QCD
	7:20 PM	Nicolas Michel-Hart	microXRF
	7:40 PM		
	8:00 PM		
	8:20 PM		

# Colloquium of interest

- See [sharepoint.washington.edu/phys/newsevents/Pages/View-Event.aspx?eid=4702](http://sharepoint.washington.edu/phys/newsevents/Pages/View-Event.aspx?eid=4702)
  - **Any week:** Go to Physics Dept home page, click on *events, events / this week* ; every Monday there is a general-interest colloquium open to the public, in A-102

Watch the talk

Watch a [video](#) of the talk.

## Story of Miharu in response to the Fukushima Daiichi nuclear power plant accident: The Miso Project

Takeshi Koike (Tohoku University)

Physics Colloquium

Date: Monday, November 02, 2015 4:00 PM

Location: PAA A-102

Small town near Fukushima (post-tsunami nuclear reactor disaster in March, 2011) took steps to protect its citizens, independent of central government: distributed sodium-iodide pills, dosimeters for school children.

J. Radiol. Prot. 34 (2014) 675

T Koike *et al*

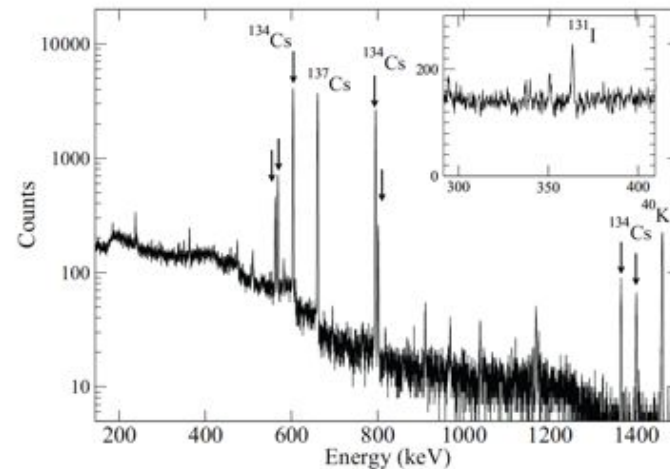

**Figure 9.** Energy spectrum of one of the soil samples in Miharu taken by an HPGe detector on 24 May 2011. Energy peaks with pointed arrows correspond to those of  $^{134}\text{Cs}$ . The inset expands a region around the 364.5 keV peak of  $^{131}\text{I}$ .

Last time

# Chi-squared distribution

$$\chi^2 \equiv \sum_{i=1}^N \frac{(x_i - \mu)^2}{\sigma^2}, \text{ sum of deviations squared, in units of } \sigma^2$$

$$p(\chi^2; \nu) = \frac{1}{2^{\nu/2} \Gamma(\nu/2)} (\chi^2)^{\nu/2-1} \exp(-\chi^2/2)$$

=  $\chi^2$  PDF for  $\nu$  degrees of freedom

$\nu$  = number of *independent* variables in sum

Example: if we average  $N$  data points to estimate  $\mu$ ,  $\nu=N-1$

- Chisq distribution is
  - Monotone decreasing for  $\nu \leq 2$
  - Peaks at  $\nu-2$  for  $\nu > 2$
  - Has mean= $\nu$ ,  $\sigma^2=2\nu$  and  $\rightarrow N(\nu, 2\nu)$  for  $\nu \rightarrow \infty$

Integral distribution:  $P(\chi^2_\alpha; \nu) = \int_0^{\chi^2_\alpha} p(\chi^2; \nu) d\chi^2 = 1 - \alpha$

So  $\chi^2 > \chi^2_\alpha$  occurs with probability =  $\alpha$

Use to test for  $N(\mu, \sigma^2)$  behavior:

Example: test hypothesis that  $\{x_i\}$  come from  $N(\mu, \sigma^2)$

Then we should have  $\chi^2 \equiv \sum_{i=1}^N \frac{(x_i - \bar{x})^2}{\sigma^2} \leq \chi^2_\alpha (\nu = N - 1)$

to have *confidence level*  $\alpha$  in our hypothesis

Rule of thumb: for  $\nu \geq 10$ ,  $\chi^2_{0.5} \equiv \nu \rightarrow \frac{\chi^2}{\nu} \approx 1$  is 50% probable

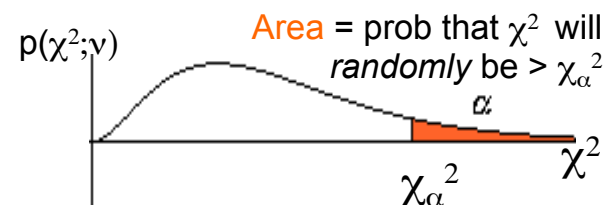
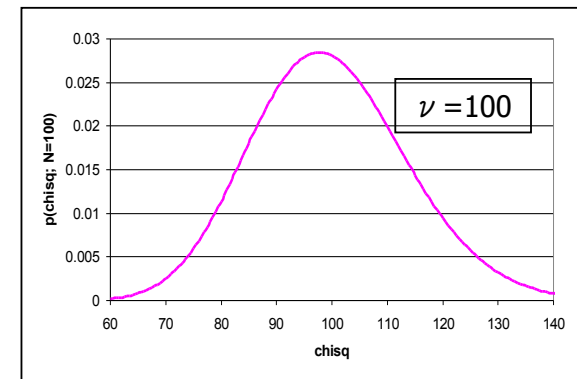
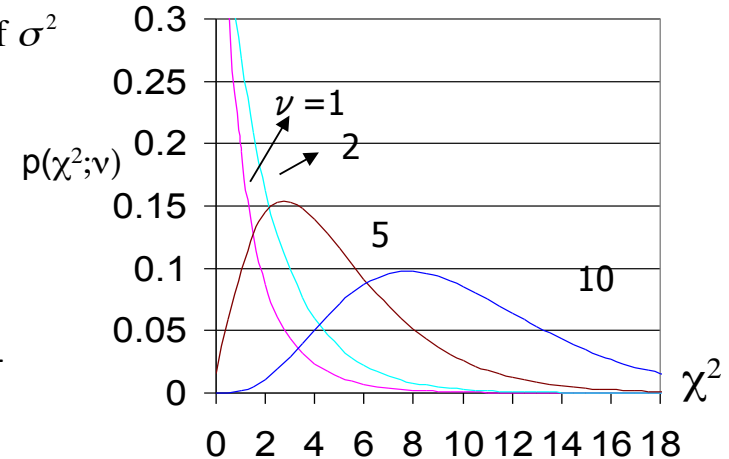

## Example: counting statistics and limits of detectability

- How can we tell if a **significant** signal exists in the presence of **background**?

$N_T$  = number of counts observed in time  $T$ ,

$N_B$  = background counts (measured in a separate run, with **no source**),

then  $N_T = N_S + N_B$  where  $N_S$  = **true** signal counts

Case where  $N_S \gg N_B$  is trivial, but **what if  $N_S \sim N_B$** ?

Assume  $T$  is long enough so all count values are “not small” ( $>5$ )

Then we expect  $N$ 's to be Gaussian-distributed, with  $\sigma = \sqrt{N}$

$$N_S = N_T - N_B, \text{ so } \sigma_S^2 = \sigma_T^2 + \sigma_B^2$$

– Suppose there is **no real activity** present, so  $N_S$  really = 0

- $\sigma_T^2 = \sigma_B^2$  so  $\sigma_S^2 = 2\sigma_B^2$  or  $\sigma_S = \sqrt{2N_B}$

So we expect  $N_S$  to be drawn from a Gaussian centered on 0 with width  $\sigma_S = \sqrt{2N_B}$

Then we should **reject** hypothesis that there is no activity present if

$N_T > L_C$  = “cut level” for decision

What should  $L_C$  be?

# Cuts and significance level decisions

We set  $L_C$  by deciding on a *significance level* = acceptable probability for being fooled by a random fluctuation (“**Type 1 error**”, false-positive rate)

If we want, eg, <5% probability of false positive result, we must set  $L_C$  at the 5% tail of Gaussian distribution.

Separate issue: rejecting hypothesis when it is actually true (“**Type 2 error**”, miss rate, false-alarm rate) – more later

**1000 experiments with mean count 0  
and standard deviation 3.5**

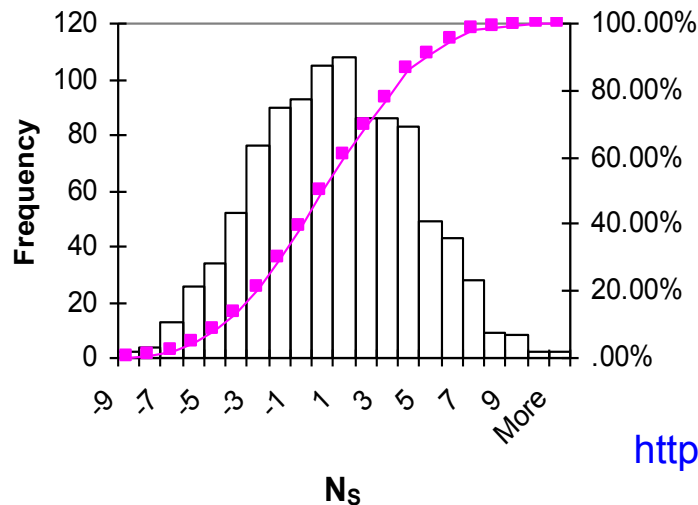

**Harder case:** Suppose real activity is present, but **below background level**, so  $N_S$  actually  $> 0$  (but  $\ll N_B$ )  
 $N_T$  is larger than  $N_B$ , but by very little!

- For a provocative look at statistical dilemma posed by low-signal experiments, see talk by Gary Feldman at

<http://www.hepl.harvard.edu/~feldman/Journeys.pdf>

# Gas ionization detectors

- Gaseous ionization detectors have many applications in nuclear / particle physics experiments
  - Charged particles leave **ionization trail** in a gas volume
    - Ion-electron pairs produced by charged particle collisions with atomic e's
    - Electrons are collected on an anode wire (and/or ions on cathode)
    - **Random process** with mean free path between collisions given by  $\lambda=1/(N_e\sigma_e)$ , where  $\sigma_e$  = collision cross-section per electron and  $N_e$  = e density
    - The mean number of collisions per unit length is  $L/\lambda$
    - Original electrons may be accelerated by E field and cascade before collection: **gas amplification**
- Gas detectors can provide precise measurements of spatial coordinates on charged particle tracks
  - Low density gas causes little scattering
  - Coordinate measurements of less than 0.1 mm are possible
  - Detection efficiencies ( $N_{\text{tracks detected}}/N_{\text{actual}}$ ) 99% or better are possible



# Categories of gas ionization detectors

Classify by **gas amplification factor**, which depends on voltage gradient used

- **Ionization detectors**
  - Relatively **low E field** between electrodes – **does not multiply electrons**
  - Useful in high-rate applications (eg, beam monitors) where signal is large, or for precision measurements (eg, calibrations)
  - Output charge is **direct measure of ionization** deposited
    - Directly related to particle properties (charge, mass, speed)
    - Useful for calibration or particle identification, but small signals
- **Proportional counters**
  - Moderate voltage accelerates electrons, **small electron amplification factor**
    - output signal remains **proportional to** original ionization deposited
  - High efficiency - small signals, but very fast output and recovery
- **Geiger counters**
  - High voltage accelerates e's, causes cascades → gas breakdown, spark path
    - **Binary signal**: yes or no – properties of original track are lost in avalanche
  - High efficiency, big fat signal – but long recovery time for gas (dead-time)

## Gas counters: 3 zones

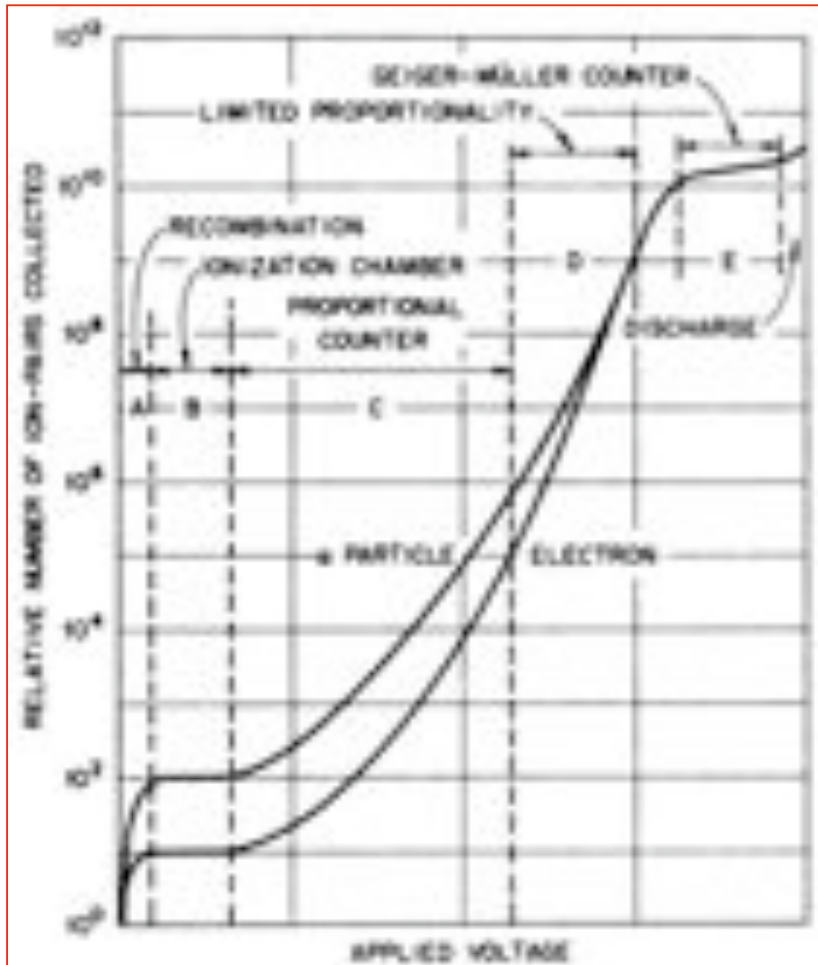

1. Ionization : low V, no multiplication
2. Proportional: linear behavior, signal proportional to original ionization
3. Geiger: breakdown, signal unrelated to original ionization

## Ionization created by charged particle in a gas

- Assume: Encounters with gas atoms are random, and characterized by mean free path (mfp)  $\lambda = \text{avg distance between collisions}$
- Avg **number of collisions** along path length  $x$ :  $\langle n \rangle = x/\lambda$
- Collision probability is **Poisson process**: exponential distribution
  - $P(x)$  = probability of **not** having a collision in distance  $x$
  - $w dx$  = probability of **having** a collision between  $x$  and  $x+dx$
  - So probability of **not** interacting between  $x$  and  $x+dx$  is  $P(x+dx) = P(x)[1 - wdx]$  {P of surviving  $x$ }{P of surviving  $dx$ }
  - So  $dP/dx = -wP$
  - Applying some calculus we get  $P(x) = C\exp(-wx)$ , where  $C=1$
  - Note that probability of collision between  $x$  and  $x+dx$  **after no collisions in distance  $x$**  is  $\exp(-wx)dx$ 
    - Mean distance between collisions  $\lambda = 1/w$
    - From definition of a cross section,  $w=N\sigma \rightarrow \lambda = 1/N\sigma$

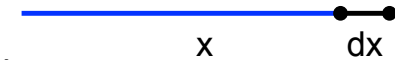

# Ionization Mechanisms

- *Primary ionization* caused by detected particle
- *Secondary ionization* due to
  - Ionization electron colliding with neighboring atoms  
 $e^-A \rightarrow e^-A^+e^-$ , . . . .
  - Intermediate excited states  $A^*$  of atom in a gas molecule
    - $e^-A \rightarrow e^-A^*$ , followed by  $A^*B \rightarrow AB^+e^-$
  - Ionization caused by UV photons emitted when excited states relax, eg  
 $A^* \rightarrow A + \gamma$
- Mean energy to create an ion-electron pair is  $\sim 20\text{-}30$  eV
  - Examples: Ar   CO<sub>2</sub>   Air   H<sub>2</sub>O   {Ar(99.6%) + C<sub>2</sub>H<sub>6</sub>(0.4%), Ar-ethane}
  - 26eV   33   35   30                   20

# Electron yields

- The number of collisions,  $k$ , in a distance  $L$  is **Poisson distributed** with frequency distribution  
$$P(L/\lambda, k) = (1/k!)(L/\lambda)^k \exp(-L/\lambda)$$
  - The probability of **at least one** ionizing collision is  $1 - \exp(-L/\lambda)$
  - Yield of ionizing collisions for **minimum ionizing particles** (m.i.p.) are shown in the table below

	Encounters/cm	$t_{99}$ (mm)	Free electrons/cm
He	5	9.2	16
Ne	12	3.8	42
Ar	25	1.8	103
Xe	46	1.0	340
CH <sub>4</sub>	27	1.7	62
CO <sub>2</sub>	35	1.3	107
C <sub>2</sub> H <sub>6</sub>	43	1.1	113

*Gases at STP,  $t_{99}$  is thickness of gas layer for 99% efficiency, and last column gives average number of free electrons produced by a m.i.p.*

# Ionization chamber applications

- Air Ionization Dosimeters

- quartz-fiber electroscopes

Lauritsen pocket dosimeter (c. 1937)



- One of the earliest radiation detectors: measure ionization in air by **rate of discharge** of sensitive electroscopes
- Wulf Electroscopie (c. 1900)

## Fluke 451 Ion chamber survey meter

349 cc air volume

ionization Chamber wall:

246 mg/cm<sup>2</sup> thick phenolic

Chamber window:

6.6 mg/cm<sup>2</sup> Mylar

Measures Alphas above 7.5 MeV,

Beta above 100 keV, and

Gamma above 7 keV



Wulf's  
electroscope.  
Drawing by  
Wulf.

Physikalische  
Zeitschrift  
10 (1909) 152

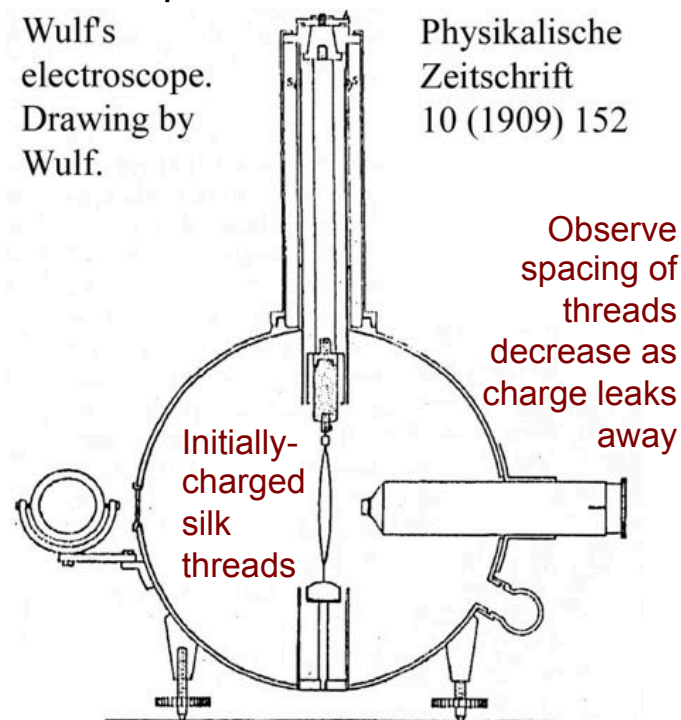

# Re-enacting discovery of cosmic rays, JW in balloon with Greg Snow (U. Nebraska) as anchorman (July 8, 2001, Snowmass, CO)

Austrian physicist Victor Hess  
on his 1912 balloon flight to study  
radiation vs altitude  
(= discovery of cosmic rays)



Ready to fly!  
(JW in Hess-like  
garb courtesy of  
UW Drama  
School)



UW Physics  
Shop-built  
Replica of  
Hess' Wulf  
Electroscope



- Cosmic ray rates measured with portable Geiger counters
- Same effects observed by Victor Hess
- See FermiNews, July 27, 2001

### Snowmass Balloon Flight 2001

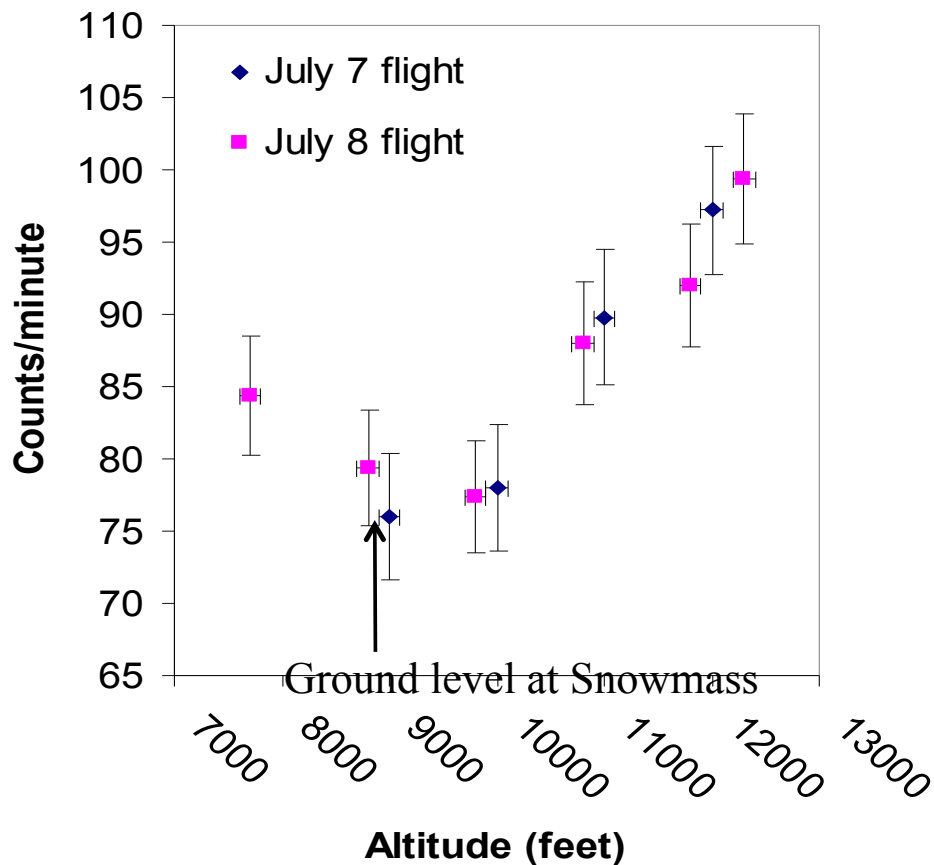

Post-flight show'n'tell at *Physics on the Mall* (thank to Leon Lederman for warming up the crowd...)





# Ionization practicalities

- Most collisions (65-80% depending on the gas) produce **only one (primary) electron** per collision
  - **Increasing** the gas pressure will **decrease** the mfp and increase the probability of more than one electron in a given path length
- Fortunately there is **secondary ionization**
  - some gas mixtures have large yields
- In an electric field  $E$ , electrons will **drift** in the gas volume with drift velocity given by  $u = \mu E$ , where  $\mu$  is the mobility
  - Drift velocities depend on many factors
    - gas mixture,  $E$  field strength, and gas pressure
    - Drift velocities in the 10 to 80  $\mu\text{m}/\text{ns}$  range are used, with 50  $\mu\text{m}/\text{ns}$  typical
  - If a magnetic field is present, there is an additional Lorentz force that results in the drifting electron following a **helical path**
  - If  $E$  is strong enough,  $e^-$ 's may not only drift but be **accelerated**
    - **Energetic electrons can cause secondary ionization: avalanche**
    - Note: **avalanche** = result of multiple stages of secondary ionization; **cascade** or shower = term for bremsstrahlung/pair production process

# Detector designs

- Detectors such as proportional tubes usually consist of an enclosed gas volume, a small diameter anode wire that has high tensile strength (must be under tension to keep straight!), and a cathode plane
  - Typical anode diameters range from 10-100  $\mu\text{m}$ , with gold plated Tungsten wire being the popular choice (why gold plated?)
  - Charged particles traversing the gas volume of these detectors leave free electrons along their trajectory
    - E field causes the ions to drift towards the anode wire
    - As they approach the wire the electric field strength increases as  $1/r$ , increasing acceleration of e's  $\rightarrow$  avalanche of secondary ionization
    - UV photons are produced as the avalanche develops; these can spread throughout the volume of the chamber causing undesirable ionization (in wrong places)
    - A quenching gas (usually organic molecules that have a large photo-absorption cross section) added to the gas will absorb most of these photons.
- Gas gains of  $10^4$  to  $10^5$  and occasionally higher are typical

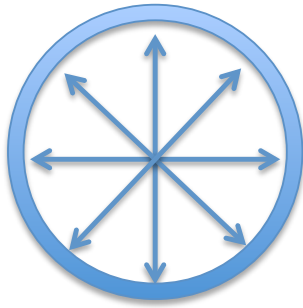

High E field near center  
wire = high voltage  
gradient: acceleration  
near wire

# Proportional counters

Avalanches for individual ionization sites do not merge to form a breakdown path

Output current is proportional to original ionization

Possible to deduce track direction (proportional chambers)

Creation of discrete avalanches in a proportional counter

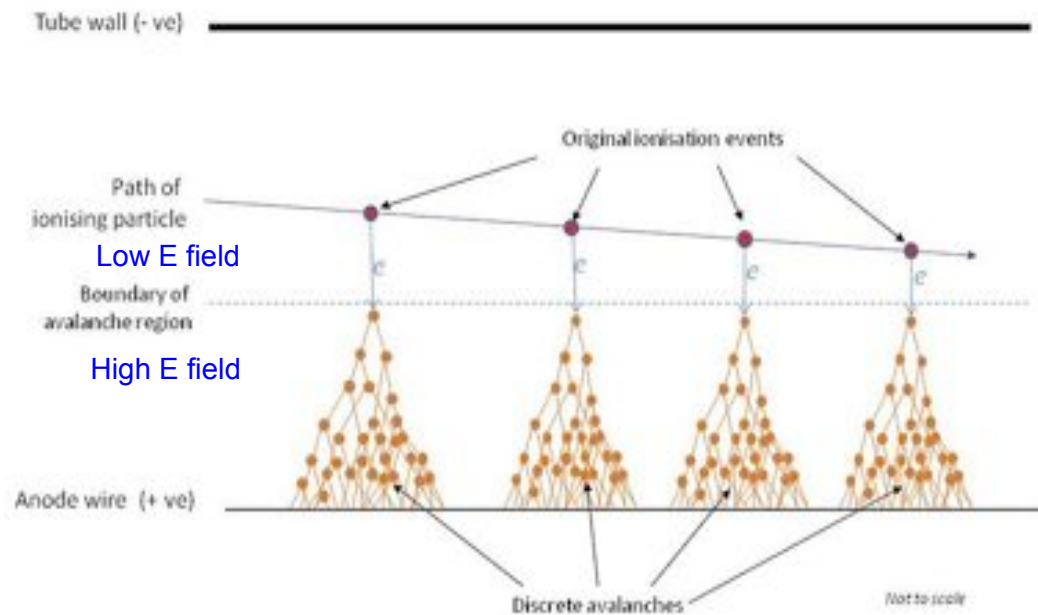

# Proportional mode detector varieties

- Proportional **tubes**
  - **Single wire** in a cylindrical conducting tube
    - Cheap and easy to make; often sealed permanent gas content
  - Gives one coordinate, plus arrival time and signal size
  - Arrange many tubes in **arrays** to form a detector layer
- Multiwire proportional chambers (**MWPCs**)
  - Array of wires with common cathode planes
  - Requires careful, precise construction, and typically needs continuous or refreshed gas supply
  - Data acquisition and analysis usually simpler (single container with carefully controlled relative wire positions)
- **Drift chambers**
  - One or only a few wires for a large volume: coordinate of track is calculated from time between trigger and collected charge signal
  - depends on uniformity of electron drift velocity

# Proportional counters

An array of proportional drift tube counters:  
each tube gives track position to 10s of microns  
([ATLAS experiment at CERN](#))



- Multi-Wire Proportional Counter – MWPC

- anode wires equally spaced at few mm  
spatial resolution of few  $\times 100\mu\text{m}$
- operated in proportional region
- each anode acts as independent counter  
measure many particles simultaneously

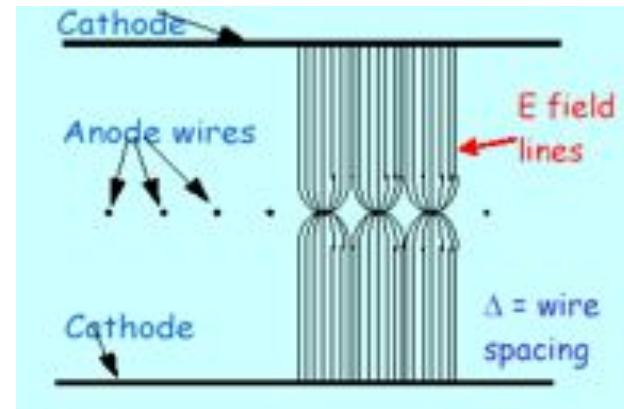

- Signal **proportional** to number of electrons collected, hence MWPC
- Measure signal amplitude on each wire and form a weighted sum-  
*center of gravity method*
  - Wire Position relative to external chamber coordinates is determined during fabrication, requires great care
    - Non uniformly spaced wires lead to E-field distortions
    - Coordinate measurement precision depends on accurate reference to external chamber coordinates
  - 3D track position determined unambiguously using 3 planes oriented so x, y, and u (ambiguity resolver for 90 deg stereo) coordinates are measured for each track

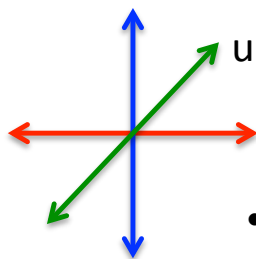

# MWPC Electric fields

- Uniform weak field (constant  $dV/dx$ , low E) far from wires
- Concentrated radial E field near wires - Rapid acceleration
- Volume with heavy ionization limited

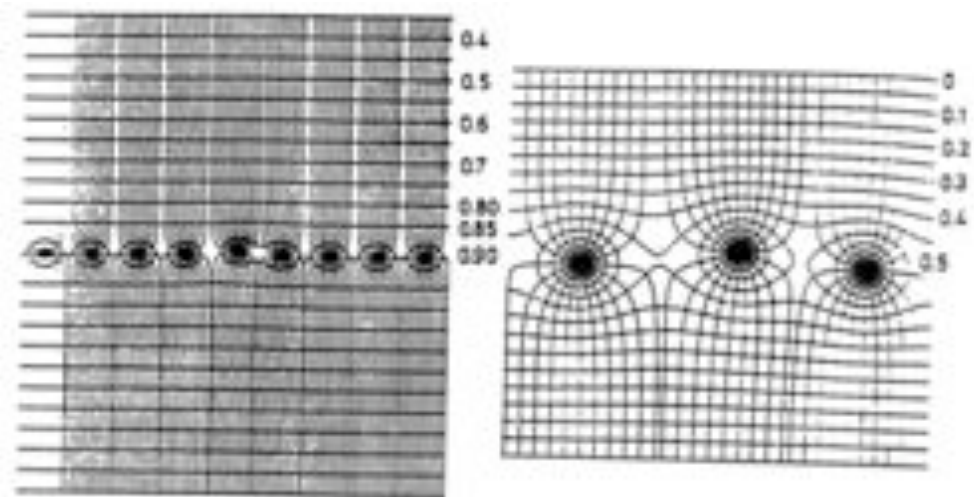
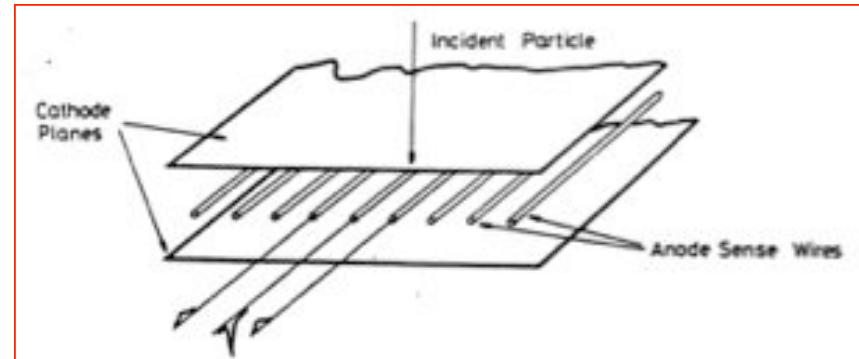

# Avalanche formation in gas detectors

- The **avalanche** near the wire develops with the electrons at the head (nearer to the wire) and the positive ions trailing behind
  - Massive ions move more slowly and drift in the opposite direction
  - Spread of electrons in the direction of the wire results from diffusion and electrostatic repulsion of the electrons
- Avalanche multiplication is characterized by **First Townsend coefficient** given by  $\alpha = 1/\lambda =$  number of ionizing collisions per unit path length.
  - For  $n$  electrons within linear distance  $dx$  there will be  $dn = n\alpha dx$  new electrons generated
  - In a distance  $x$  we get  $n = n_0 \exp(\alpha x)$  electrons where  $n_0$  is original number of electrons: **positive** exponential !
- Avalanches **merge** to form ionized path between electrodes = spark channel (same as lightning)



# Avalanche formation

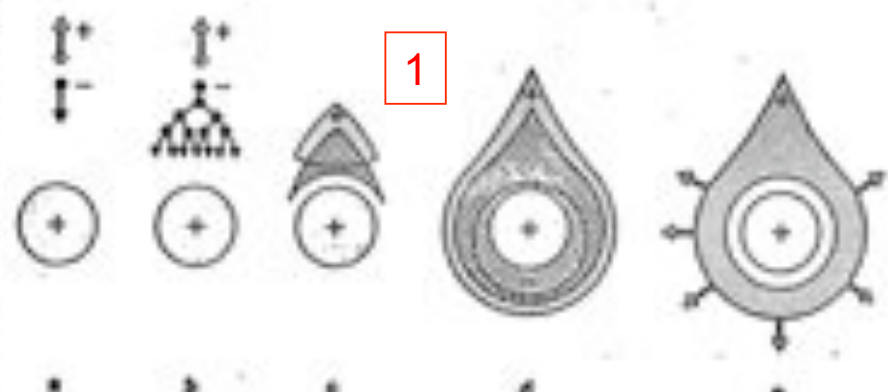
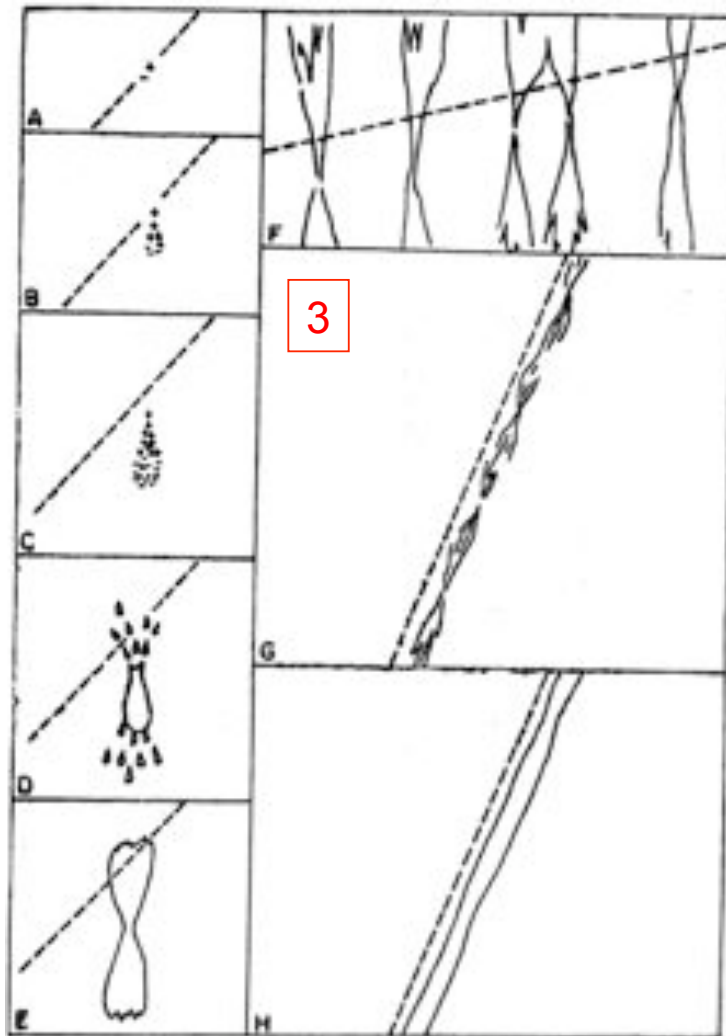

49 Time development of an avalanche in a proportional counter<sup>(49)</sup>. A single primary electron proceeds towards the anode, in regions of increasingly high fields, experiencing ionizing collisions; due to the lateral diffusion, a drop-like avalanche, surrounding the wire, develops. Electrons are collected in a very short time (1 ns or so) and a cloud of positive ions is left, slowly migrating towards the cathode.

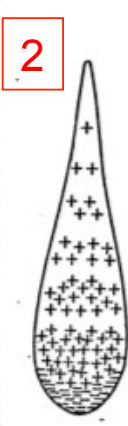

1. Near anode wire in a proportional counter
  2. Free floating ions in a spark chamber drift toward anode
  3. Development of spark channel
- spark chamber = geiger mode gas chamber used to visualize tracks (use cameras to record paths)

Fig.2 The Evolution of a Spark Channel

# Drift chamber detectors

- Cylindrical Drift Tube – a simple and effective device
  - Consists of a hollow conducting cylinder with a coaxial, tensioned wire of radius  $r = a$

**Gauss' law**  $\int \mathbf{E} \cdot \mathbf{n} \cdot d\mathbf{S} = q/\epsilon_0$   
 $E(r) = q/2\pi\epsilon_0 r = -d\phi/dr$   
solve for  $q$ , with  $\phi(b) = 0$   
 $\phi(r) = V_0 - (q/2\pi\epsilon_0)\ln(r/a)$

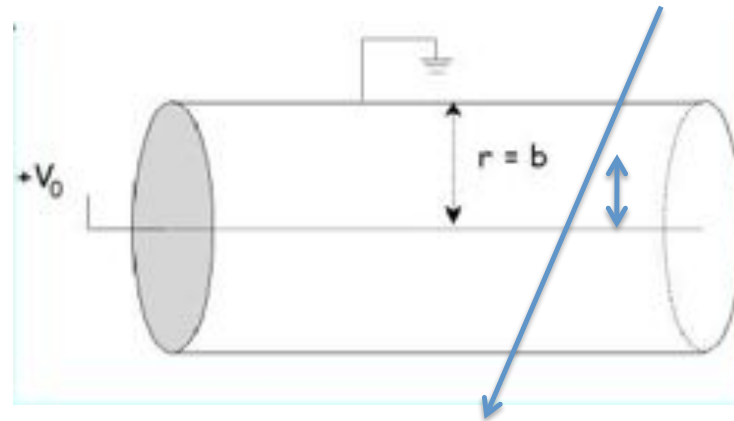

- Because of the drift field is proportional to  $1/r$ , the drift velocity will not be constant as the electron drifts towards the wire
  - **Isochrones**, equal time surfaces, are concentric with wire but unequally spaced
- Only 1 data channel needed per tube
  - Pulse **timing** gives **coordinate**, pulse area gives ionization of track
- Many variants of this typical design are possible
  - Can add field shaping electrodes or wires to alter the field lines so that the drift field is uniform and the isochrones are uniformly spaced

# Drift tubes and chambers

- Goal: uniform field in drift region, high field gradient near anode
- Different strategies possible to achieve this
- Choose gas mix to provide desired drift velocity
  - Usually: noble gas as base, with additives to tweak properties

Drift velocity vs E in:

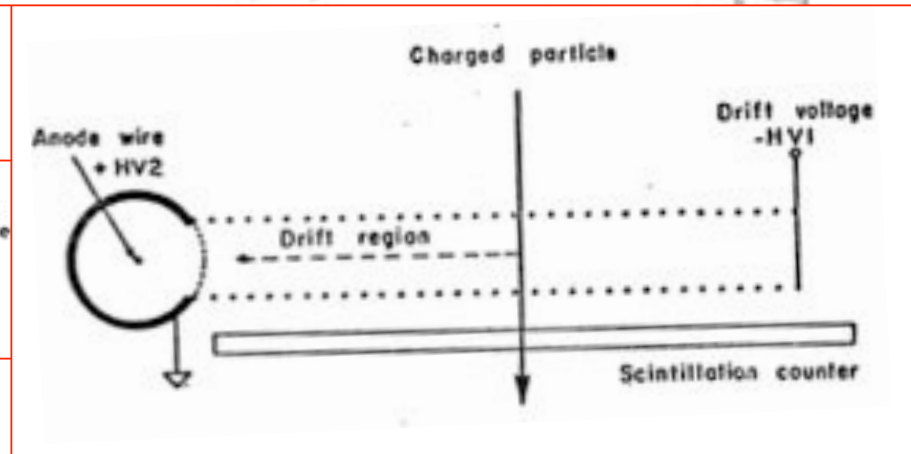
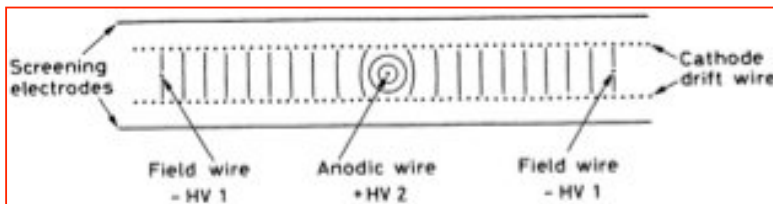
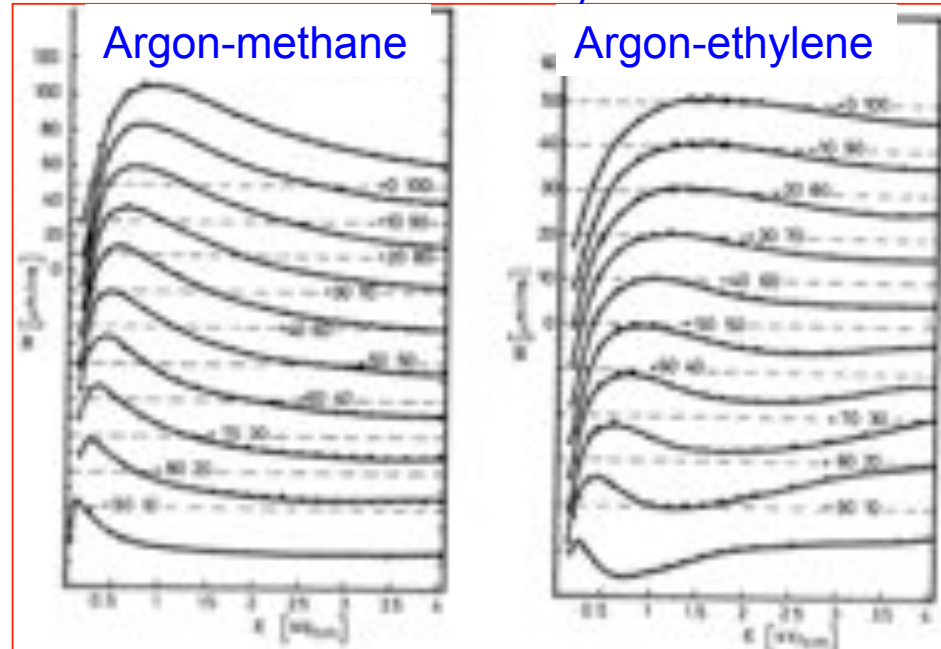

# Multichannel Drift Chambers

- Anode and field shaping electrodes designed to give an electric field configuration to insure constant drift velocity
  - Time from passage of charged particle through to avalanche on wire gives distance ( $\Delta t = t_{avl} - t_0 = d/v$ )
  - External trigger, usually with scintillating counters (plastic) defines  $t_0$
- Very precise measurements, less than 100  $\mu\text{m}$  for drift distances of a few centimeter
  - High accuracy usually requires frequent calibration of drift time in the course of data taking
- Very large systems are possible

# UW-built Muon Drift Tubes for ATLAS

- The ATLAS muon drift tubes are operated at 3 bar absolute pressure with an Ar/CO<sub>2</sub> 93:7 gas mixture.
  - see <http://ieeexplore.ieee.org/iel5/9356/29714/01352083.pdf> for details
- 30,000 tubes assembled @ UW
- Need to work >10 years with no maintenance!

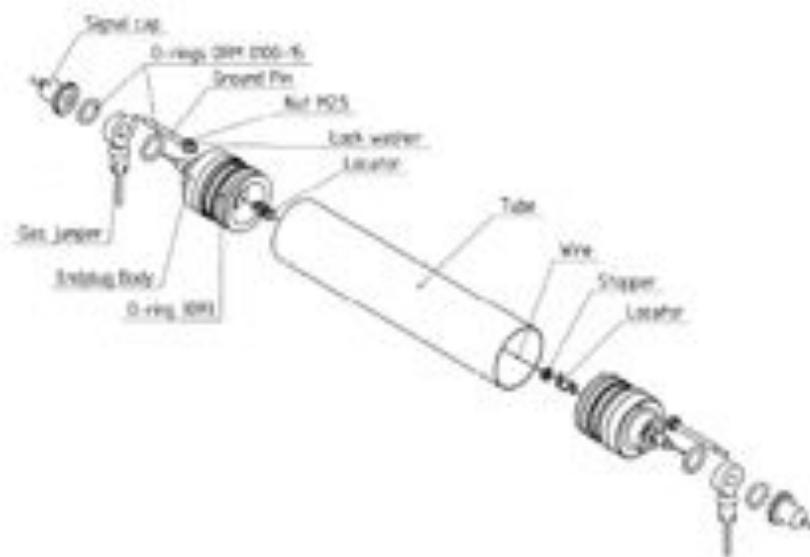
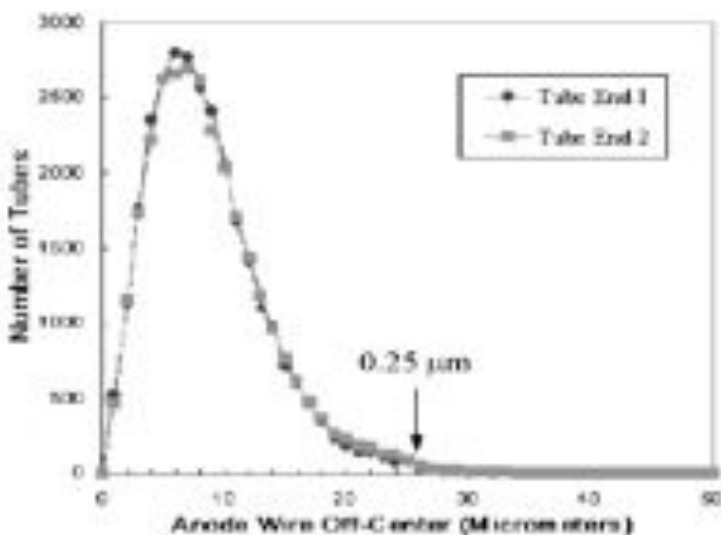
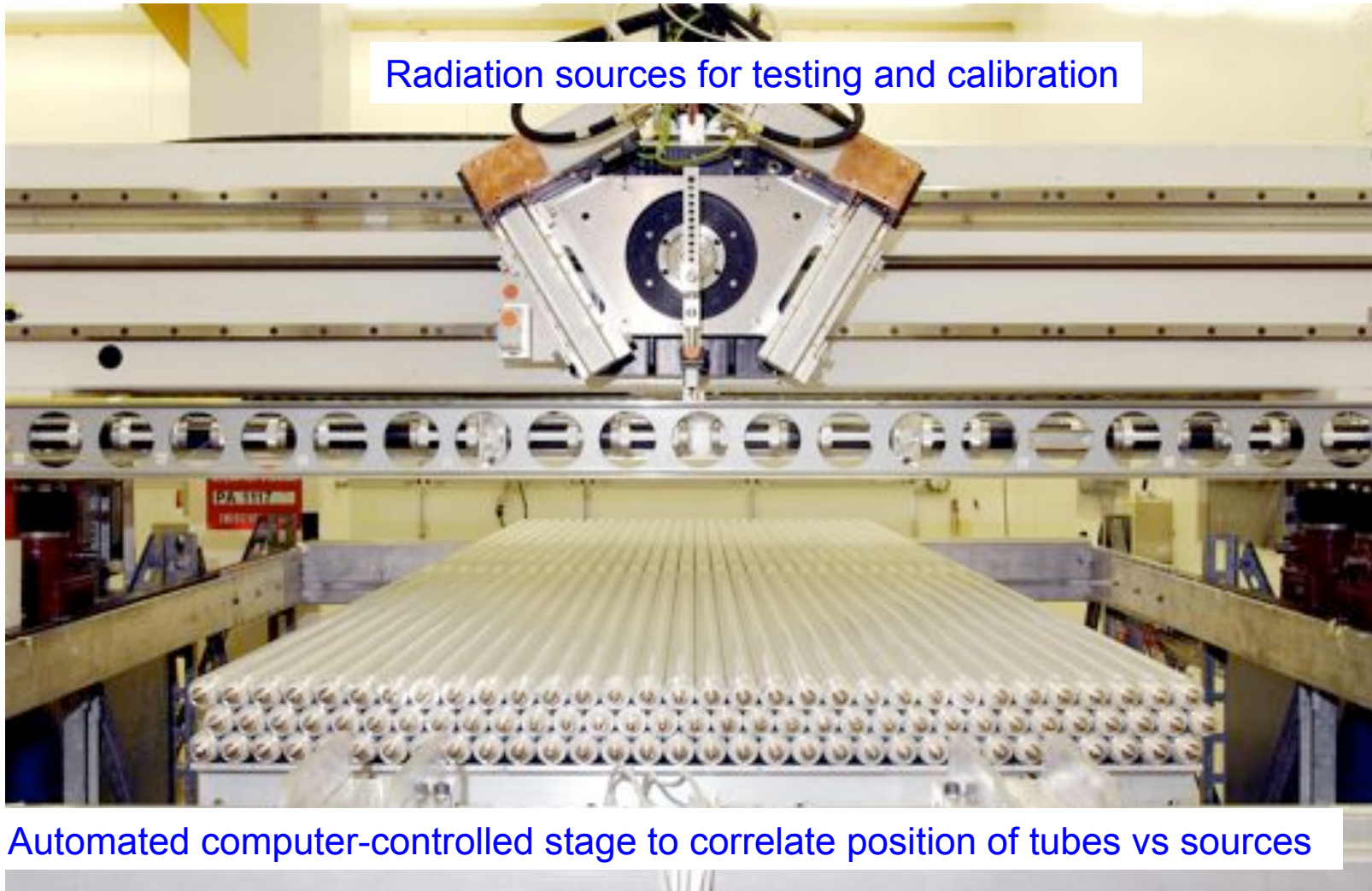

Fig. 1. Components of an ATLAS precision drift tube.

# Testing and QC of assembled chambers





# Installation in ATLAS detector at LHC

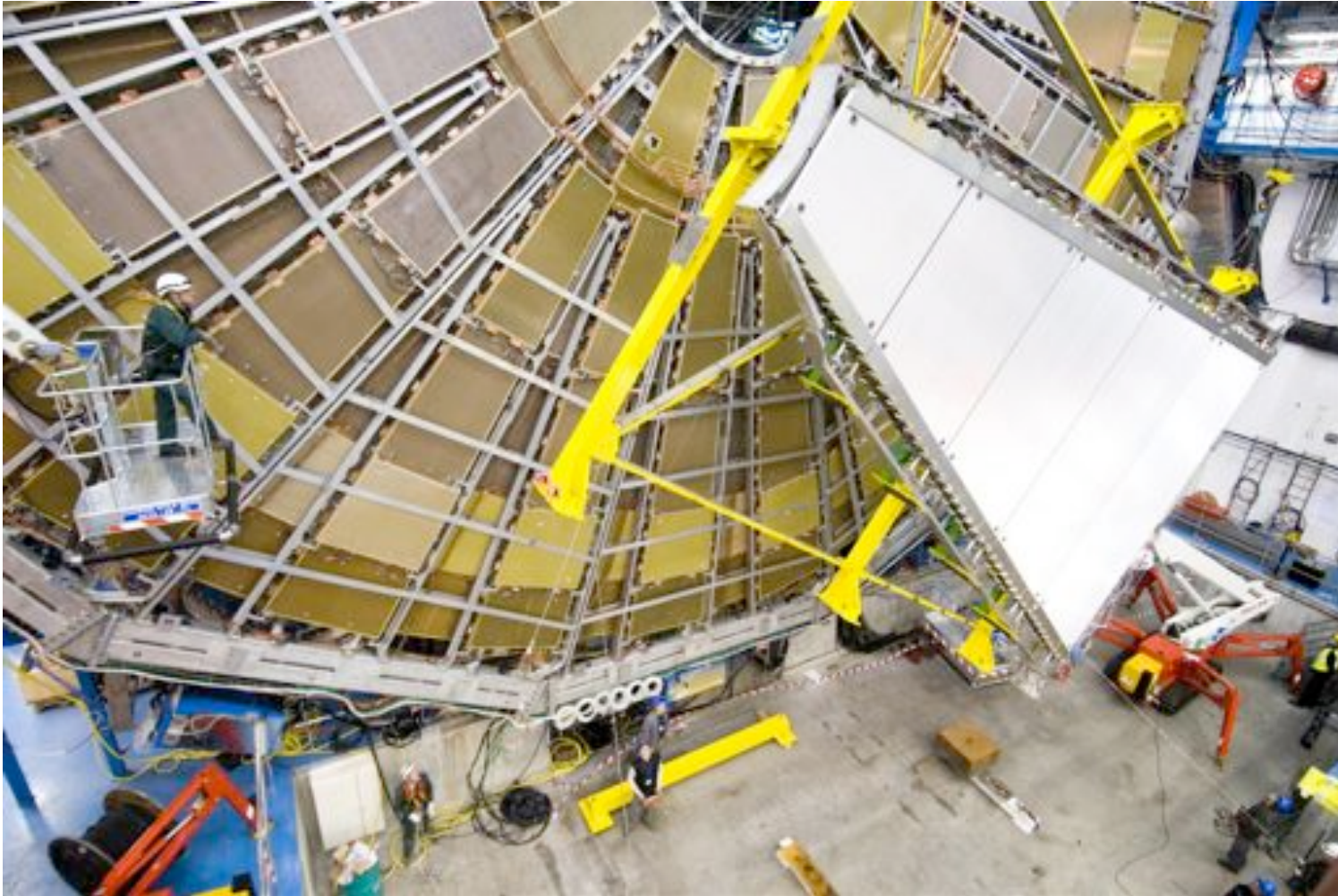

# Time projection chamber

- 3D 'imaging' tracker based on drift chamber principle
  - Arrays of charge collection electrodes provide **image** of track's ionization trail in 2 dimensions
  - Measurement in 3<sup>rd</sup> dimension (distance of track from electrode array plane) comes from drift time
- **Liquid argon** chambers
  - MPCs and TPCs typically use noble gas such as Ar, He, Xe
    - Avalanches do not cause chemical reactions
    - Usually doped with traces of organic gases (complex molecules) to fine-tune drift and gas amplification properties
  - **Liquid** Ar works even better: denser, not too expensive, easier to handle than LHe, and even has slightly lower ionization work function value,  $\sim 20$  eV/e



# Time projection chambers

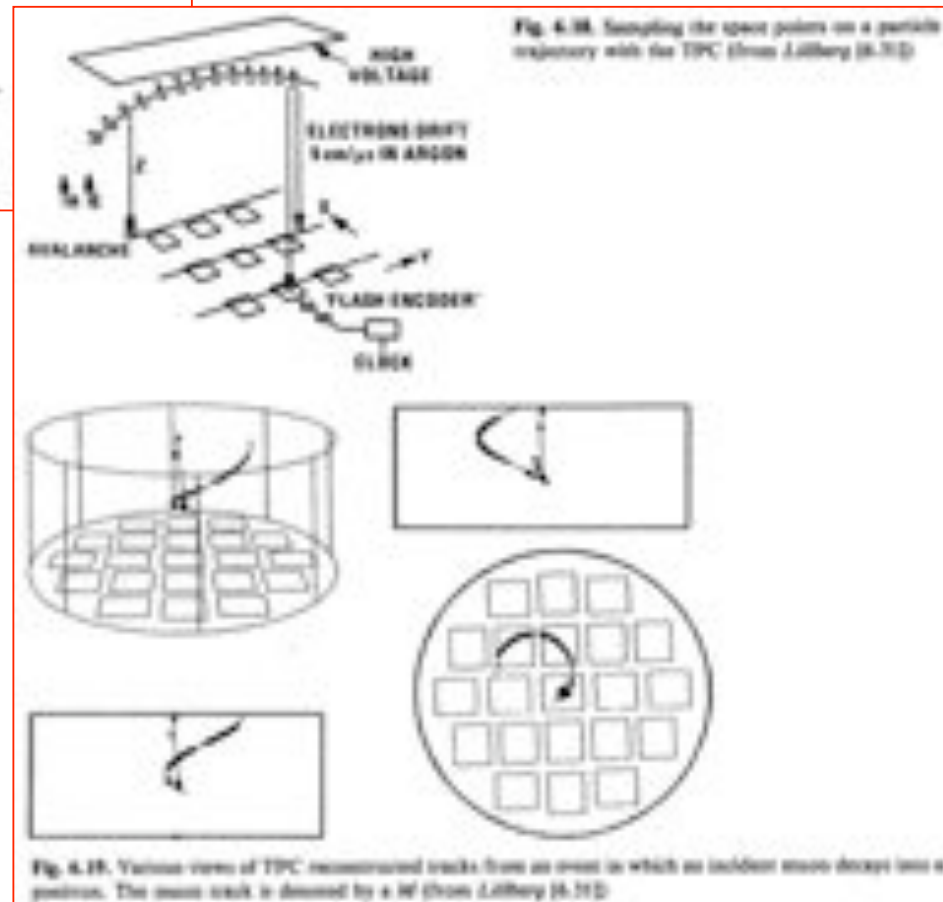
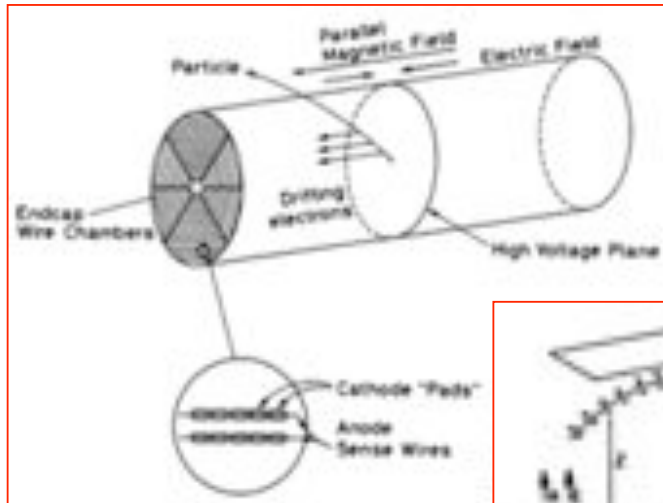

## Images from TPCs: 1st detected neutrino interaction in T2K

- Scintillator bar hits shown – TPC track images = tracks in between bars
  - Interaction occurred upstream, in another detector

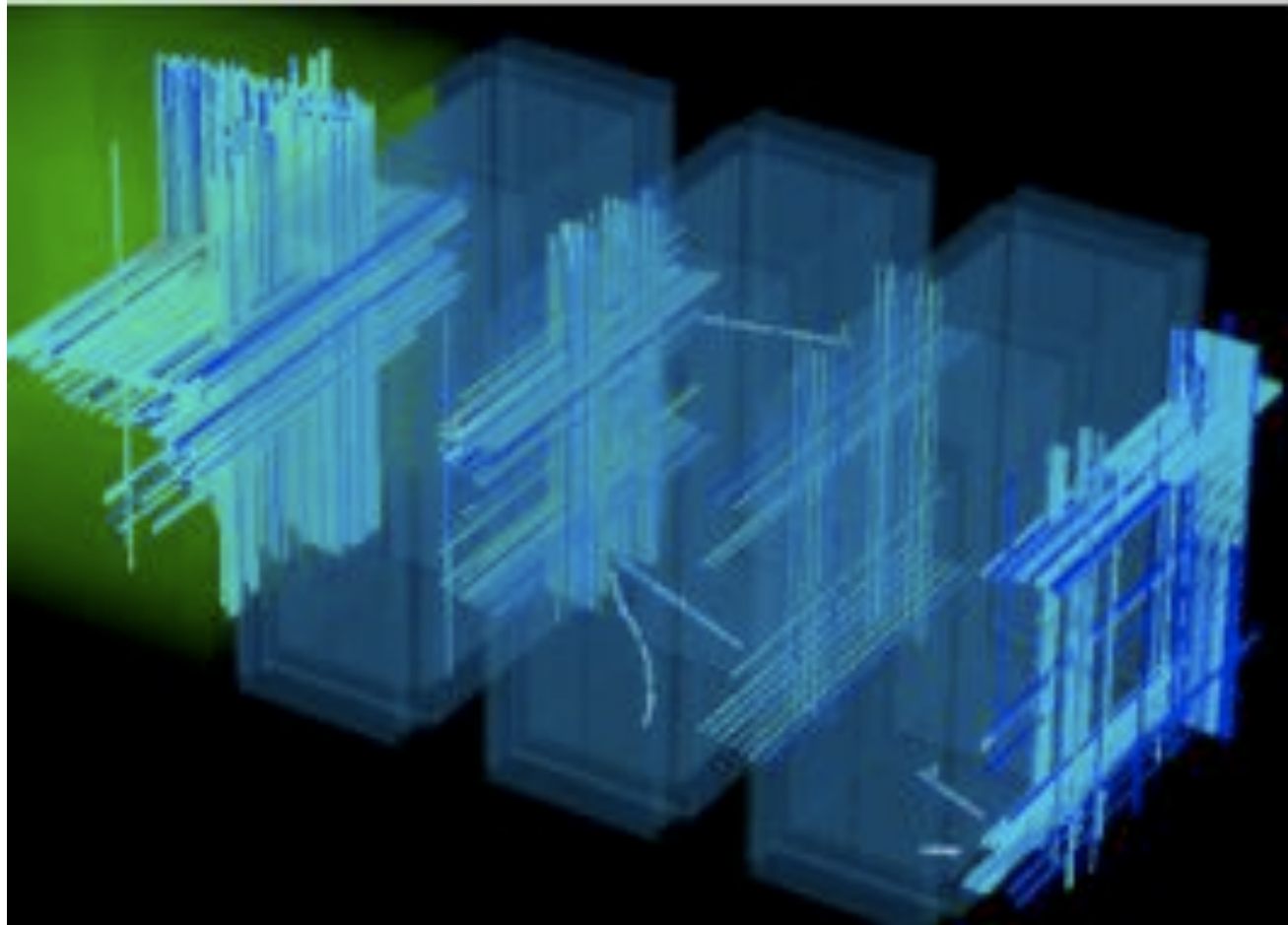

## Getting 2 coordinates with one MWPC layer

### Cathode strip chamber (CSC)

Used in ATLAS detector at LHC

- Usual array of anode wires gives particle's x coordinate
- Cathode plane divided into strips of width  $\sim 5.6$  mm in y direction
  - Find y coordinate by interpolating charge on 3  $\sim$  5 adjacent strips
  - Measure  $Q_1, Q_2, Q_3 \dots$  with 150:1 SNR to get  $\sim 60$  micron precision.
  - Position accuracy unaffected by *gas gain* or *drift time* variations.
  - Accurate *intercalibration* of adjacent channels essential.

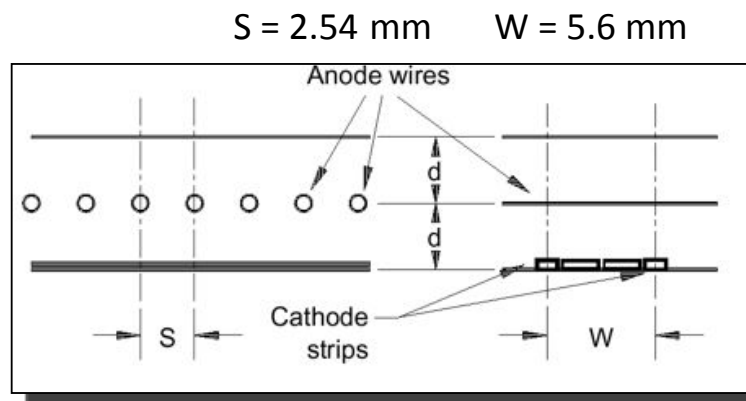
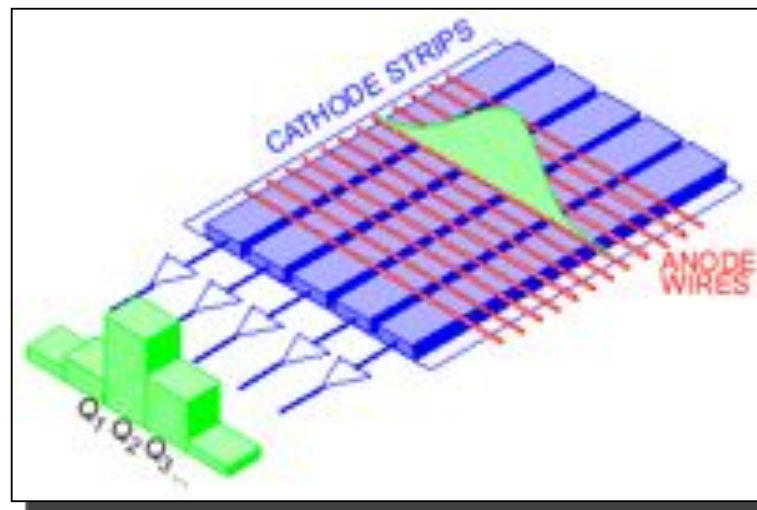

# Geiger counters

- Geiger mode: high enough E field to cause breakdown (arc) for small ionization deposit
  - Breakdown mode: longer recovery time
  - No info on ionization, direction

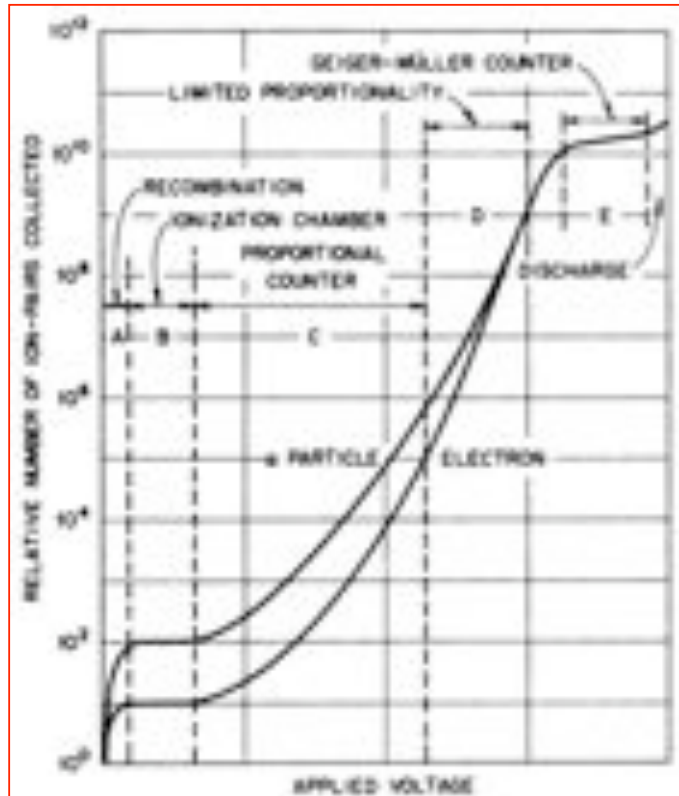
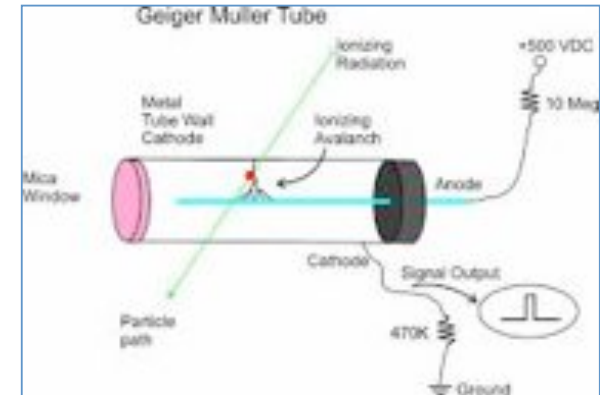

# Geiger-Müller tubes in detectors

- Rossi, Occhialini and Blackett (1933):
  - arrays of geiger tubes with Rossi's new invention (vacuum-tube coincidence unit)
  - layers of geiger tubes to trigger a cloud chamber

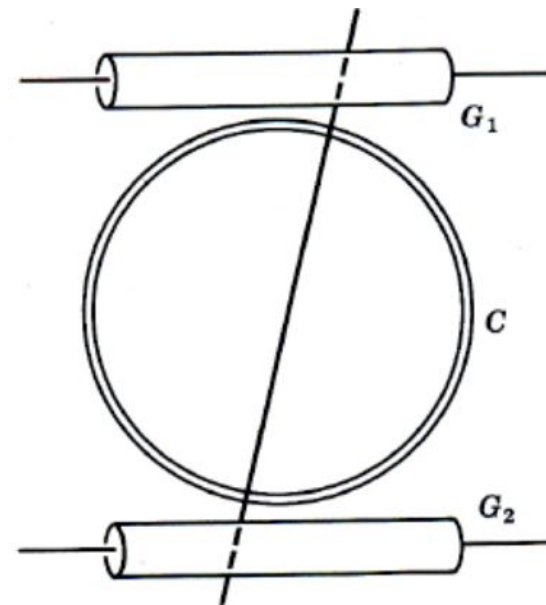
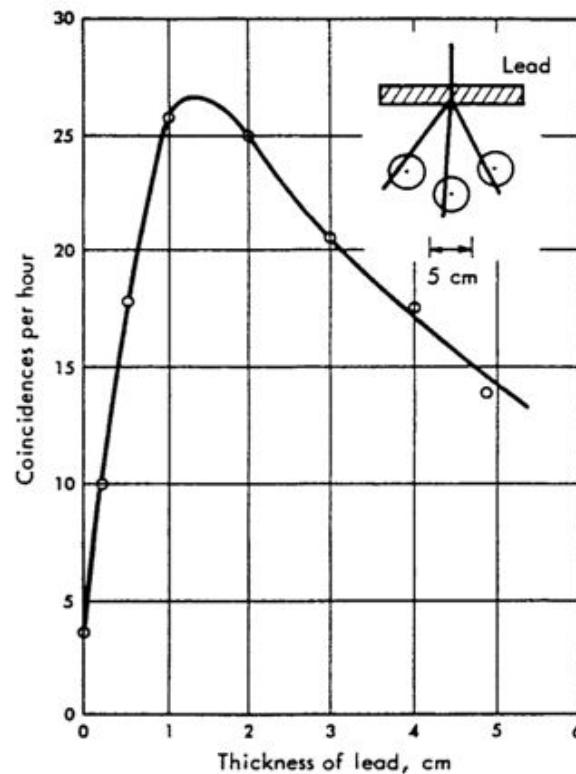

Fig. 3. Data obtained by Rossi in 1933. The inset shows a schematic diagram of a shower event that triggers multiple Geiger tubes in coincidence.

# Semiconductor detectors: Basic physics

- Recall:
  - In solids, where atoms are not widely separated, energy levels  $\rightarrow$  bands
    - Conductors have empty levels in valence band = states for electrons to move into
    - Insulators have filled valence bands = immobile electrons
    - Semiconductors have small gap to higher (conduction) band
  - Impurities alter intrinsic material behavior
    - Donor impurities have weakly bound electrons  $\rightarrow$  n-type semiconductor
    - Acceptor impurities have “holes” in valence band  $\rightarrow$  p-type semiconductor
  - p-n junctions
    - Electrons and holes near junction create a region with electric field

electrons from n-region diffuse into holes in p-region.

Resulting field causes drift of electrons, balancing out the gradient.

n-region develops + charge at interface  $\rightarrow$  lowered electron energy levels relative to p-region with excess – charge. In between= depletion zone.

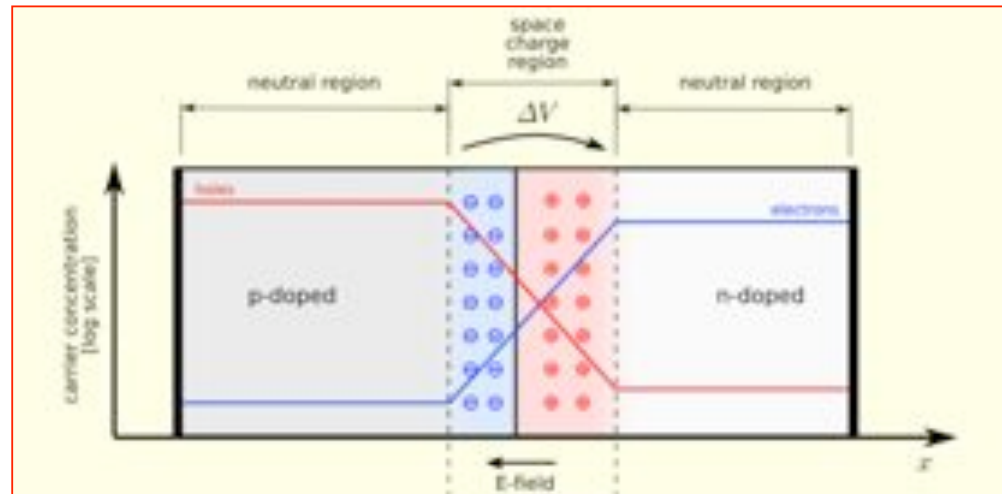

# Physics of semiconductor detectors

- Intrinsic (undoped) semiconductor
    - Supply E to jump band gap
  - Doped p-n junction: E field gradient = V
    - Add external V (bias)
  - **Forward** bias = +V to p side
    - Reduces potential barrier
    - $e^-$  s flow from n side to p, holes flow from p to n
    - (Conventional current I flows from p to n)
  - Depletion region = good detector
    - Charge created there is quickly swept out
    - Fast pulse signal
  - **Reverse** bias = - V to p side
    - Increases depletion-zone width
    - Reduces capacitance
- Good features for use as radiation detector

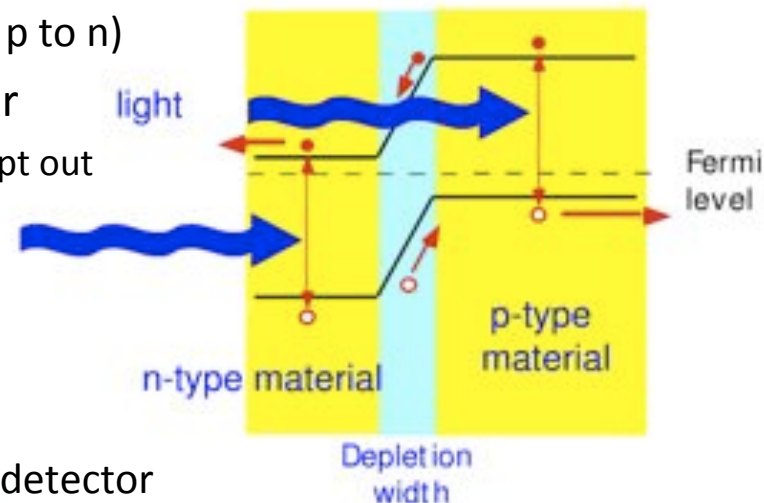
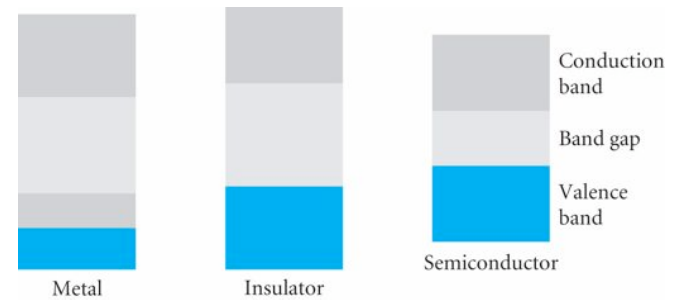



# Si strip detectors for ATLAS inner tracker at CERN

- strips 0.075mm apart
- path of the particle measured to  $\sim 0.02\text{mm}$
- 6 million channels total

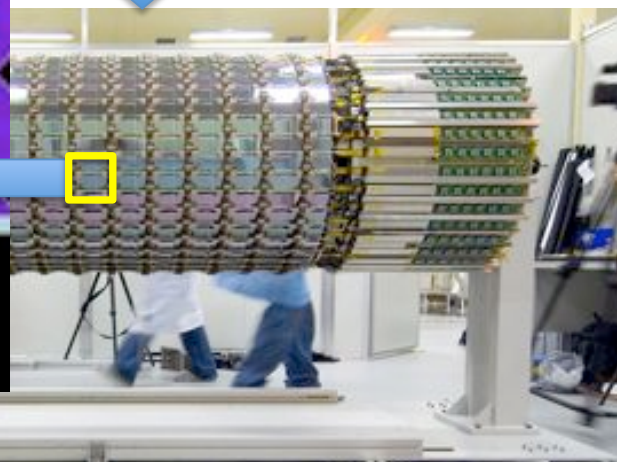
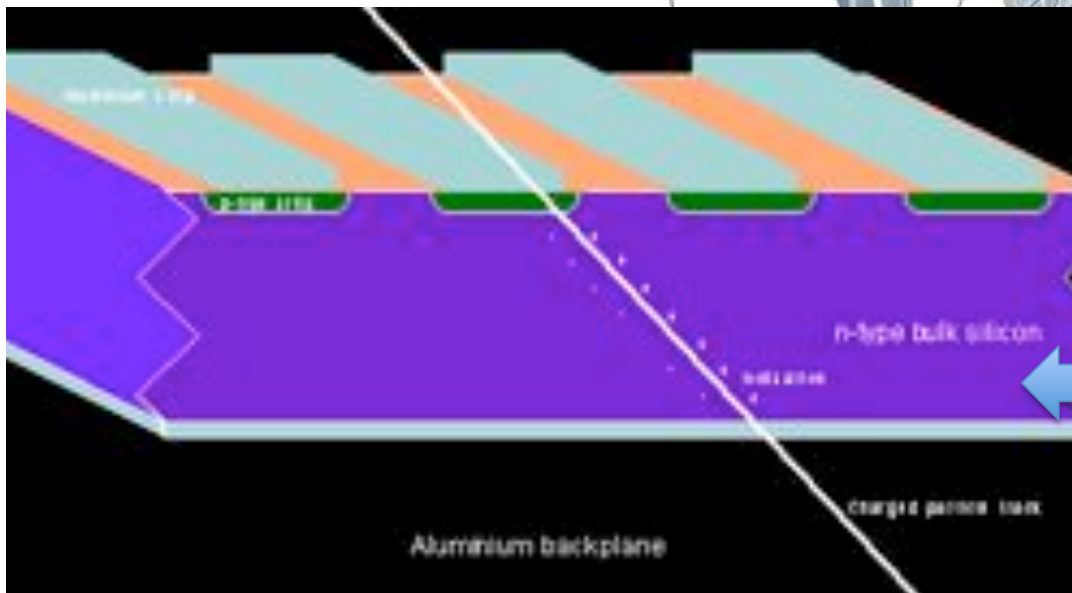
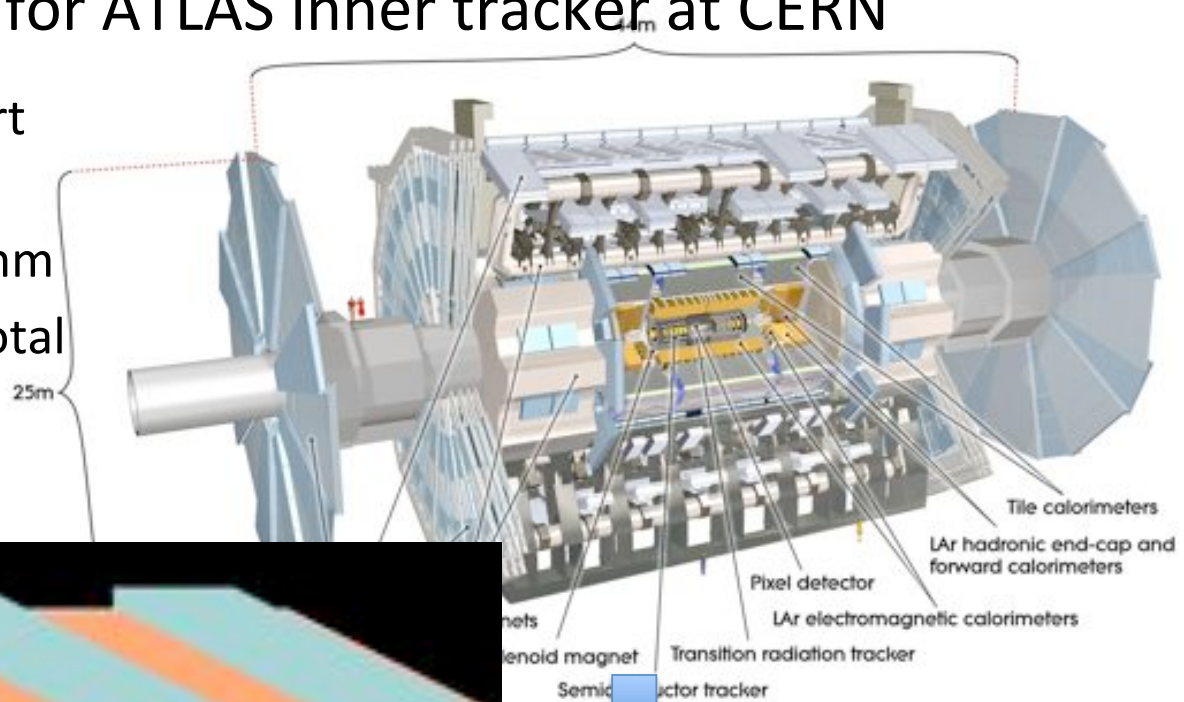



## Examples of solid-state detector applications

- Si detectors for astrophysical antiparticle cosmic-ray detection
  - Large lithium-loaded wafers to increase cross-section for capture process
  - Target and detector combined
  - Prototype wafer: 10cm dia x 2mm thick

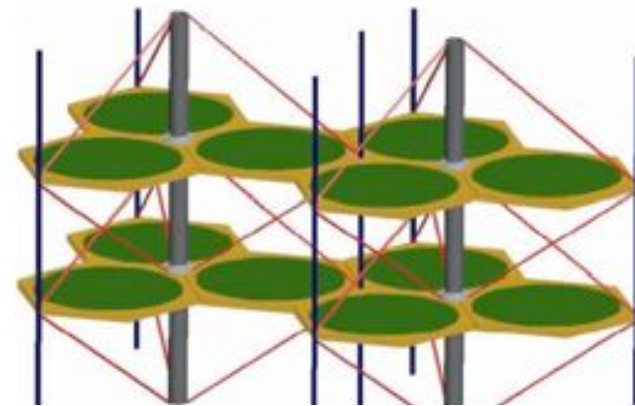
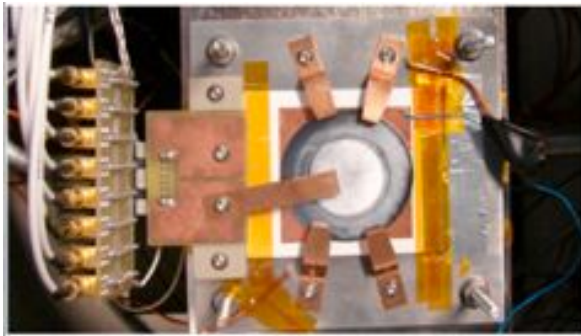

Prototype array for balloon flight

## More SSDs

- CZT (Cadmium-Zinc-Telluride) = high-resolution SSD

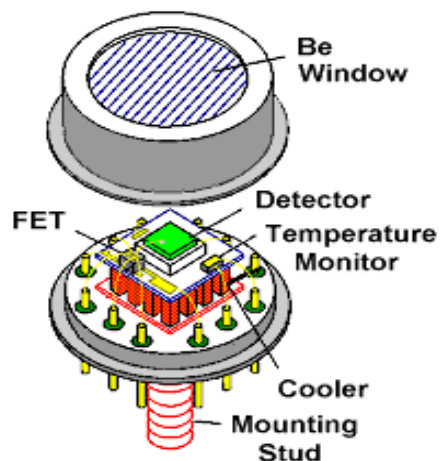

Application: metallurgical analysis of bronze in knee of Benvenuto Cellini's statue of *Perseus*, to ensure proper restoration.

- The bronze alloy was found to be composed of CU + tin ( $\sim 3.6\%$ ), lead ( $\sim 6\%$ ), antimony ( $\sim 1\%$ ), iron ( $< 1\%$ ) and silver ( $< 1\%$ ).

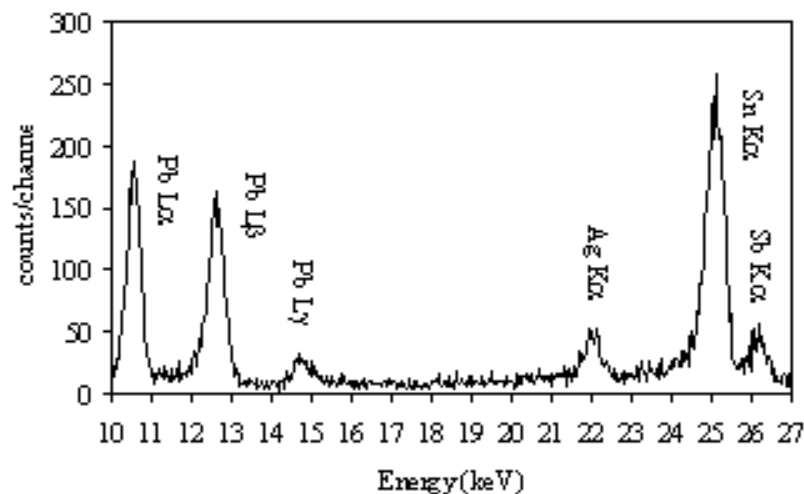

# MPPC (Multi-Pixel Photon Counter)

New Hamamatsu device:

- Multiple APD (avalanche photodiode) pixels operated in Geiger mode.
- Sum the output from APD pixels.
- Allows counting single photons, or detection of multiple photons.

# High gain: 10<sup>5</sup> to 10<sup>6</sup>

# Room temperature operation

# Low bias (below 100 V) operation

# Insensitive to magnetic fields

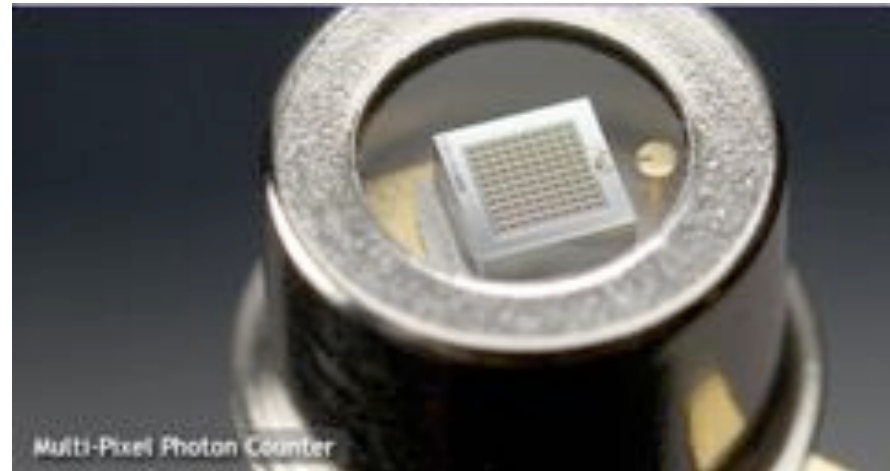
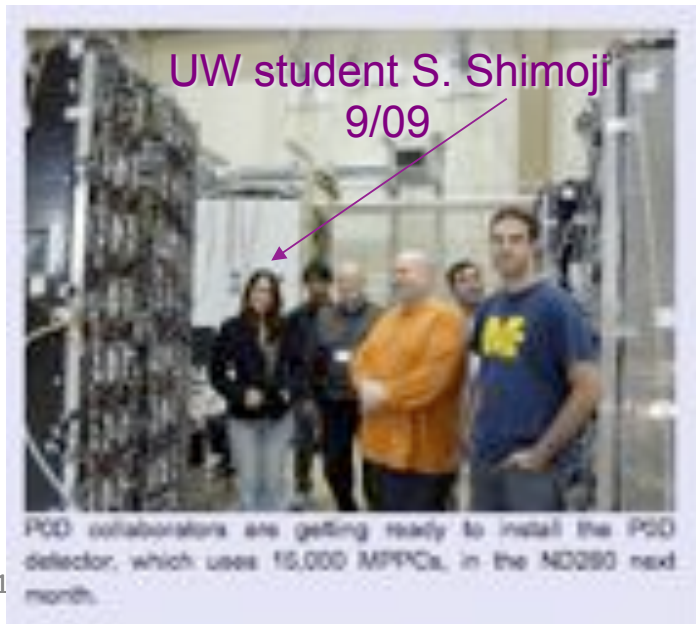

64 channels (optical fibers from scintillator bars), mounted on 8x8 array of MPPCs

Photos: Hamamatsu Photonics

# CCDs (charge-coupled devices)

CCDs → large number of pixels + fast readout

- 1980s technology, now highly optimized
- Array of photodiodes
  - Captures image photons
  - Photoelectrons shifted out by rows
- Shift registers
  - Serial readout to transfer register
  - Serial readout from transfer register
    - Passive pixel: One pixel at a time goes through single output amplifier
    - Active pixel: each pixel has amplifier built-in
- Can't detect single photons

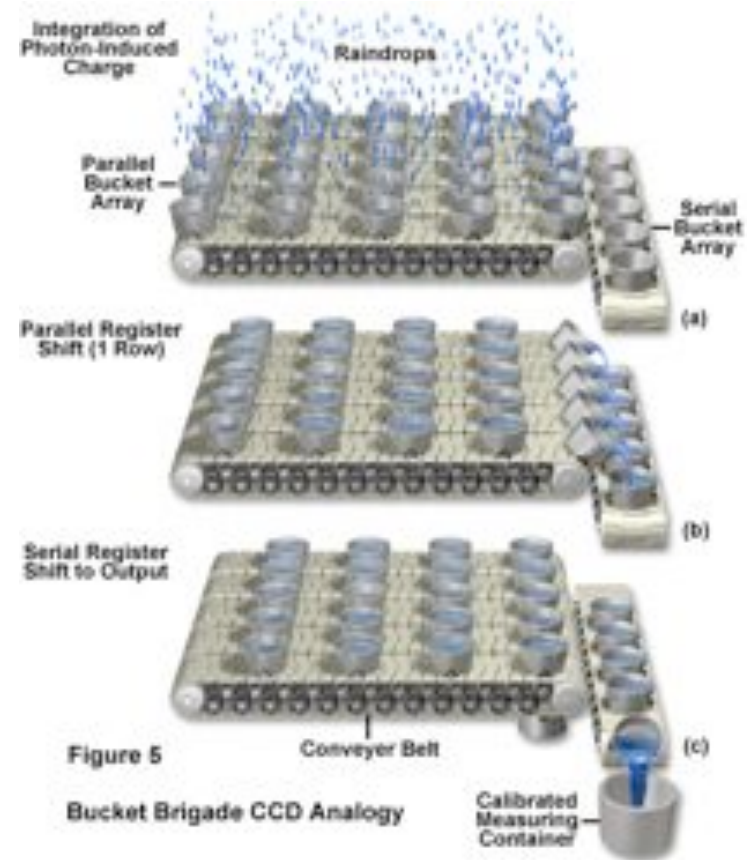

# Electron-multiplying CCDs (EMCCD)

- EMCCDs include higher potential drop multiplication registers
  - Physical electron multiplication bypasses amplifier noise
    - Shot noise unavoidable
  - Single-photon sensitivity
  - Slower than CCD due to extra register

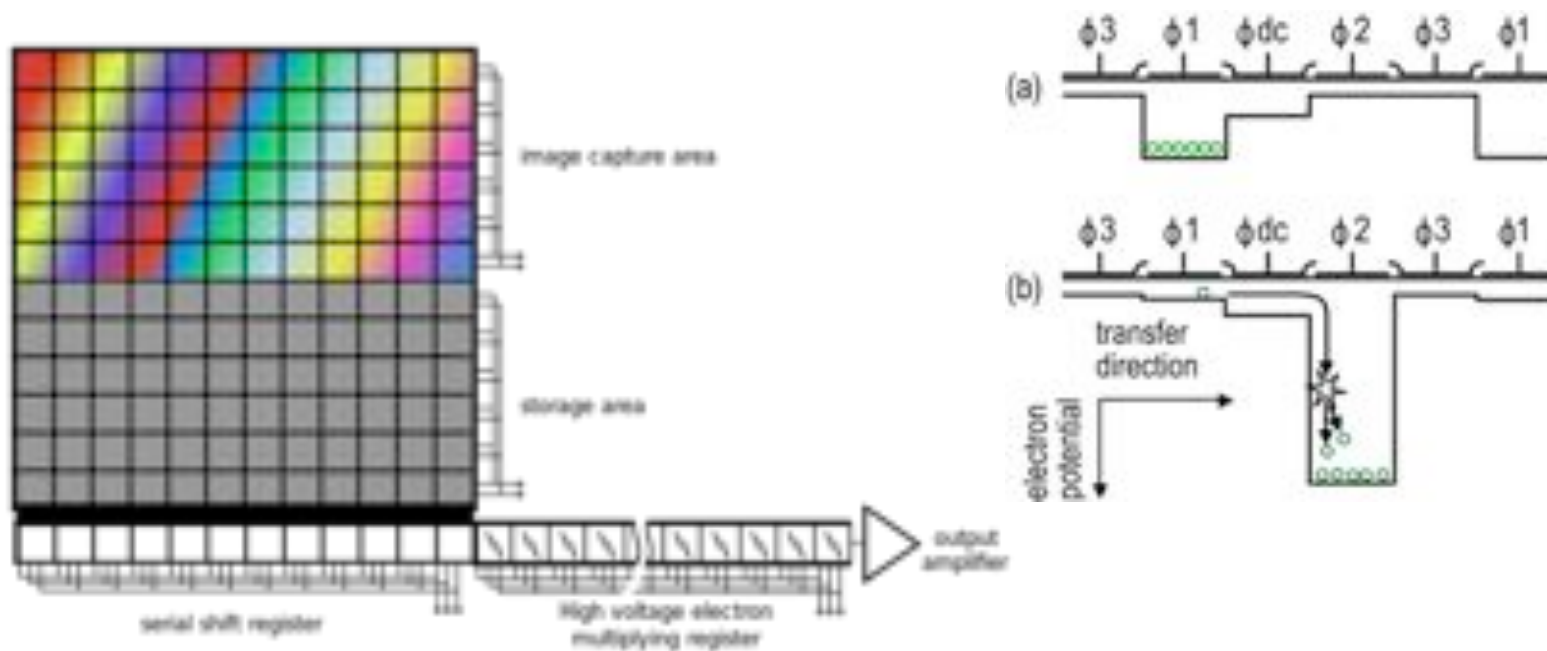



# Solid-State Detectors

- Use reverse-biased p-n junction to collect charge from ionization
- Si and Ge have much higher  $dE/dx$  than scintillator or gas detectors
  - Larger signals with sharper resolution in E
  - High stopping power:

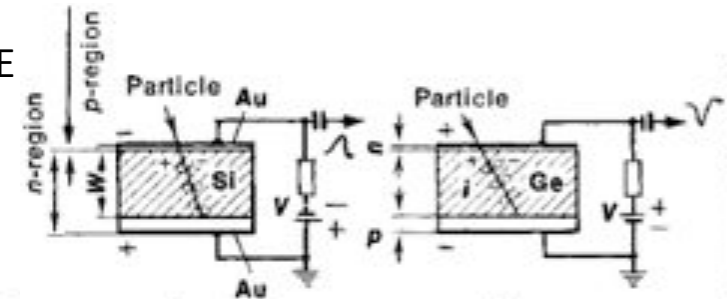
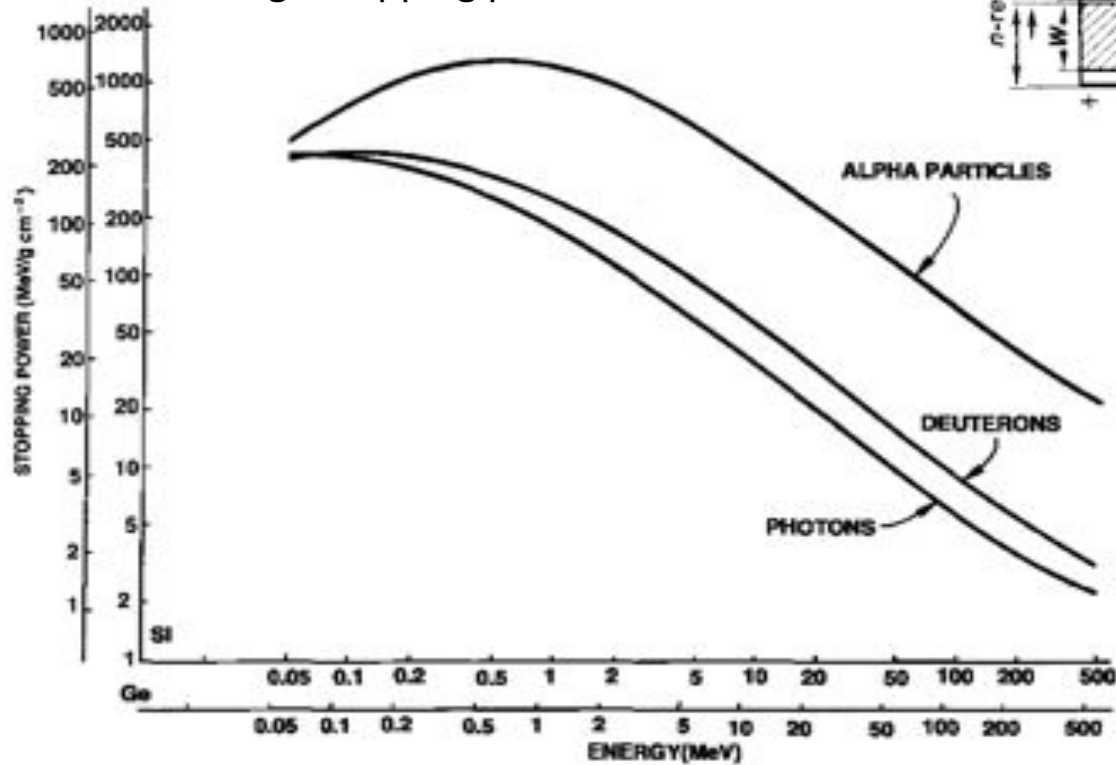

## Ge and Si

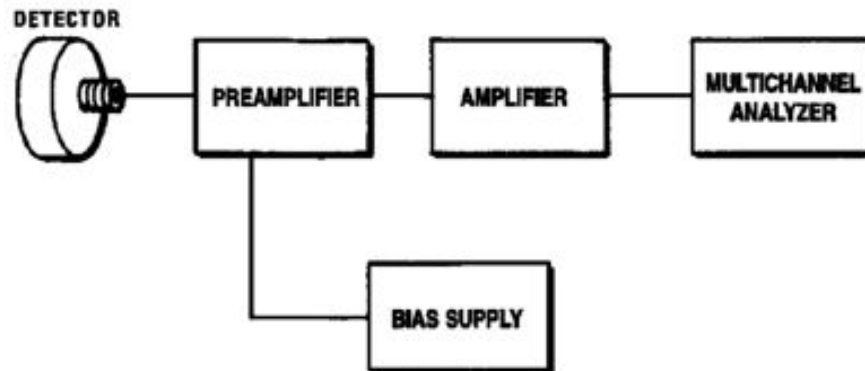

- Noise is limitation:
- Ge must be operated at liquid nitrogen temperatures
- Si may be used with Peltier cooling
- Low noise amplifiers needed
  - Built in FET preamp

Si Strip detector for x-rays

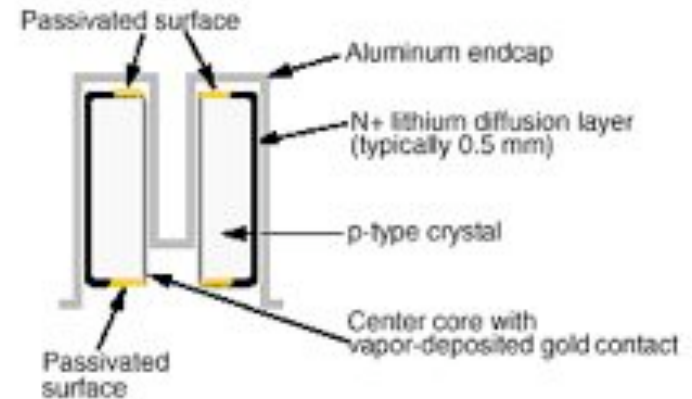

Ge detector with well for small samples

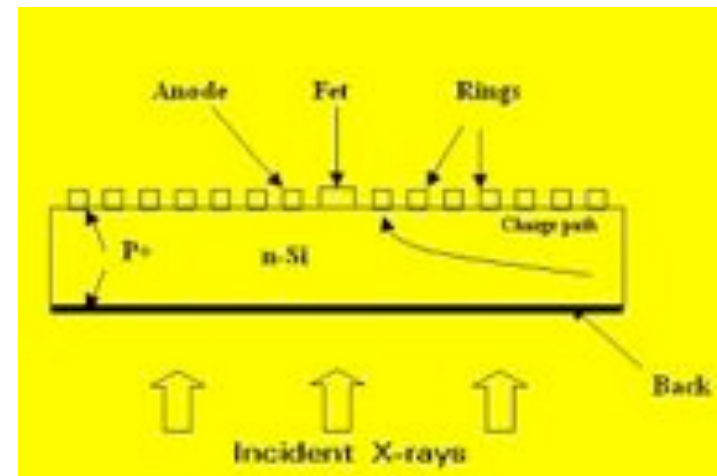



# Higher resolution of SSDs

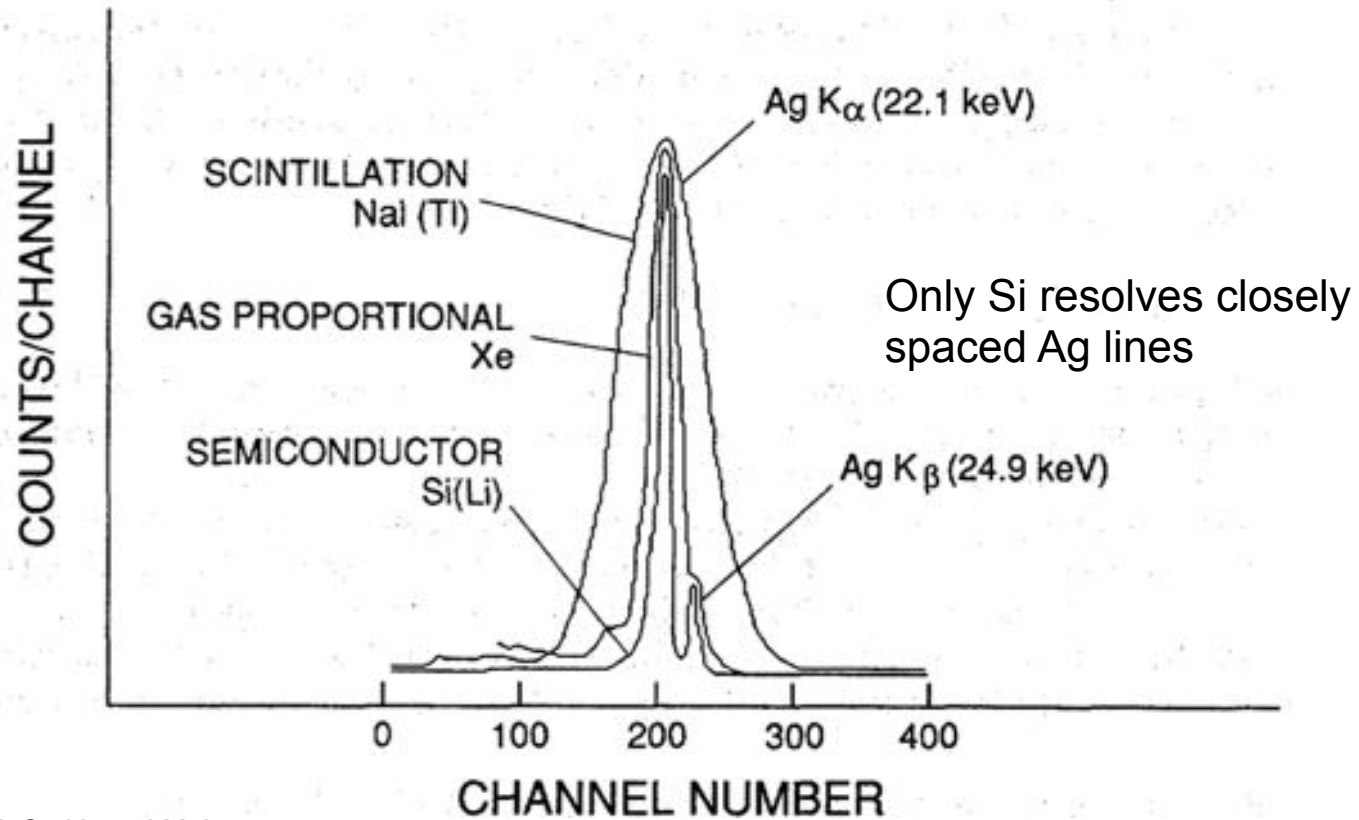

From: H. Smith and M. Lucas,  
*Gamma ray detectors*

# Deterioration of germanium detector with neutron exposure

