

Design and Construction of a Field Test Site to Evaluate the Effectiveness of a Compost Amended Bioswale for Removing Metals from Highway Stormwater Runoff

WA-RD 724.1

Mark W. Maurer

March 2009

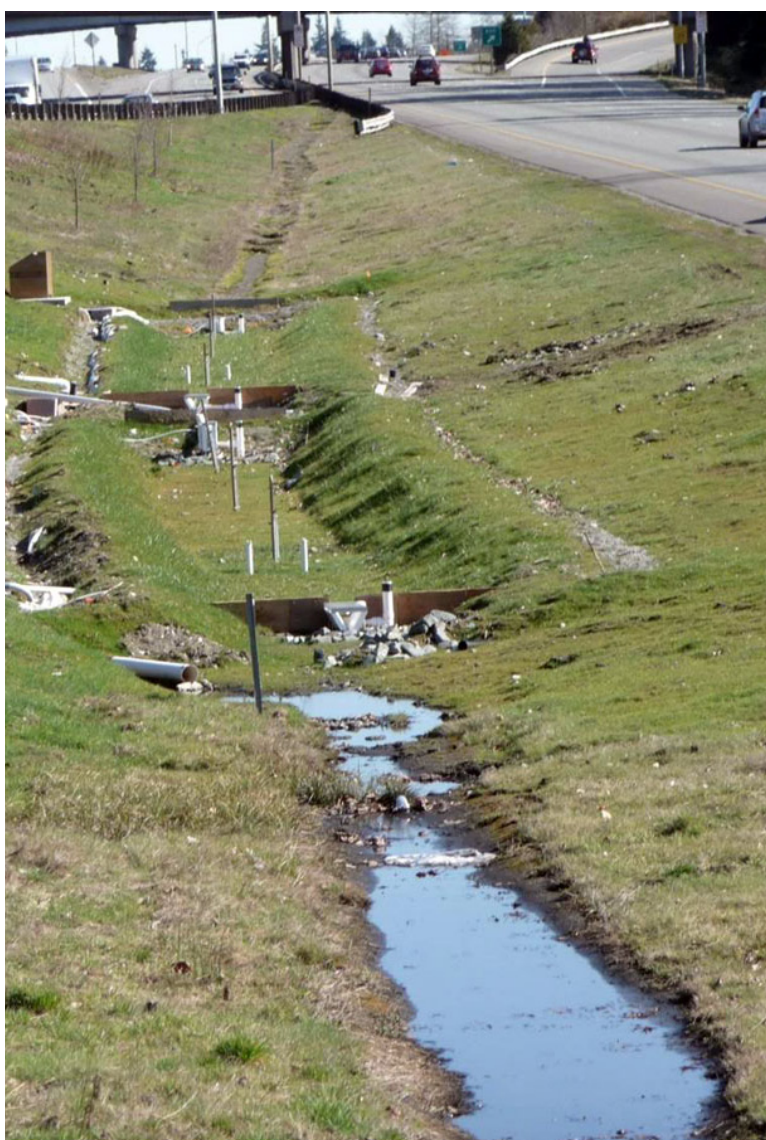

Design and Construction of a Field Test Site to Evaluate the Effectiveness
of a Compost Amended Bioswale for Removing Metals from Highway
Stormwater Runoff

Mark W. Maurer

A thesis
submitted in partial fulfillment of the
requirements for the degree of

Master of Science

University of Washington

2009

Program Authorized to Offer Degree
Civil and Environmental Engineering

University of Washington
Graduate School

This is to certify that I have examined this copy of a master's thesis by

Mark W. Maurer

and have found that it is complete and satisfactory in all respects,
and that any and all revisions required by the final
examining committee have been made.

Committee Members:

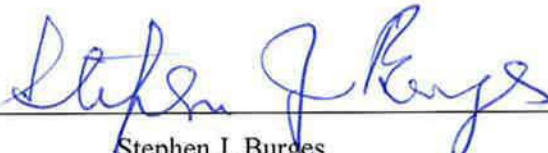

Stephen J. Burges



Michael T. Brett

Date: 13 March, 2009

TECHNICAL REPORT STANDARD TITLE PAGE

1. REPORT NO. WA-RD 724.1	2. GOVERNMENT ACCESSION NO.	3. RECIPIENTS CATALOG NO	
4. TITLE AND SUBTITLE Design and Construction of a Field Test Site to Evaluate the Effectiveness of a Compost Amended Bioswale for Removing Metals from Highway Stormwater Runoff	5. REPORT DATE March 13, 2009		6. PERFORMING ORGANIZATION CODE
	8. PERFORMING ORGANIZATION REPORT NO.		
7. AUTHOR(S) Mark Maurer	10. WORK UNIT NO.		
9. PERFORMING ORGANIZATION NAME AND ADDRESS HQ Design Office, Highway Runoff Section 310 Maple Park Ave, MS 47329 Olympia, WA 98504-7329	11. CONTRACT OR GRANT NO.		
	13. TYPE OF REPORT AND PERIOD COVERED		
12. SPONSORING AGENCY NAME AND ADDRESS	14. SPONSORING AGENCY CODE		
	15. SUPPLEMENTARY NOTES This study was conducted in cooperation with the U.S. Department of Transportation, Federal Highway Administration.		
16. ABSTRACT Stormwater from impervious surfaces generally has to be treated by one or more best management practices (BMP) before being discharged into streams or rivers. Compost use for treating stormwater has increased in recent years as trials show that compost amended soils and compost blankets prevent erosion and improve water quality. Most of the trials to date have focused on applications where the stormwater sheet flows across a compost amended area or into a retention basin amended with compost. These types of installations are applicable to many locations, but there is a need for an end-of-pipe treatment that can handle concentrated flows. This is particularly true in roadway projects that are linear in nature and cut across land features and go from cut to fill sections frequently. Bioswales are an approved BMP to remove nutrients from stormwater and are widely used in highway construction to move and treat stormwater. However, bioswales are not currently approved for dissolved metal removal from stormwater. Compost amended soils have shown an increased capacity to remove dissolved metals from stormwater. This research will evaluate the effectiveness of a compost amended bioswale to remove dissolved metals from highway runoff. This thesis details the steps necessary for the site selection, design, and implementation of a stormwater BMP field test.			
17. KEY WORDS Stormwater, bioswale, compost, water quality, monitoring		18. DISTRIBUTION STATEMENT	
19. SECURITY CLASSIF. (of this report) None	20. SECURITY CLASSIF. (of this page) None	21. NO. OF PAGES 70	22. PRICE

In presenting this thesis in partial fulfillment of the requirements for a Master's degree at the University of Washington, I agree that the Library shall make its copies freely available for inspection. I further agree that extensive copying of this thesis is allowable only for scholarly purposes consistent with "fair use" as prescribed by the U.S. Copyright law. Any other reproduction for any purposes or by any means shall not be allowed without my written permission.

Signature Man W. Spence

Date 3/10/09

University of Washington

Abstract

Design and Construction of a Field Test Site to Evaluate the Effectiveness of a Compost Amended Bioswale for Removing Metals from Highway Stormwater Runoff

Mark W. Maurer

Chair of Supervisory Committee:
Professor Stephen J. Burges
Civil and Environmental Engineering

Stormwater from impervious surfaces generally has to be treated by one or more best management practices (BMP) before being discharged into streams or rivers. Compost use for treating stormwater has increased in recent years as trials show that compost amended soils and compost blankets prevent erosion and improve water quality. Most of the trials to date have focused on applications where the stormwater sheet flows across a compost amended area or into a retention basin amended with compost. These types of installations are applicable to many locations, but there is a need for an end-of-pipe treatment that can handle concentrated flows. This is particularly true in roadway projects that are linear in nature and cut across land features and go from cut to fill sections frequently. Bioswales are an approved BMP to remove nutrients from stormwater and are widely used in highway construction to move and treat stormwater. However, bioswales are not currently approved for dissolved metal removal from stormwater. Compost amended soils have shown an increased capacity to remove dissolved metals from stormwater. This research will evaluate the effectiveness of a compost amended bioswale to remove dissolved metals from highway runoff. This thesis details the steps necessary for the site selection, design, and implementation of a stormwater BMP field test.

Table of Contents

List of Figures	iii
List of Tables	iv
Introduction	1
Literature Review	2
Study Design	4
Site Selection	4
1. Initial Criteria	4
2. Initial criteria vs. final criteria	8
Site Analysis	10
Design and Construction of Bioswales and Monitoring System	10
Washington State Dept. of Ecology Requirements	15
Methodology	16
Soil Testing – Determination of bulk density	16
Vegetation monitoring	17
Measuring water contributing area	17
Measuring runoff inflow and swale outflow	18
Precipitation	19
Equipment calibration	19
Water quality testing	21
Site Preparation and Equipment Installation	22
Initial Vegetation	30
Observations supporting the Need for French Drains and Drains for Pit Rain Gauges	31
Monitoring Schedule	32

Budget and Costs.....	33
Summary and Conclusions.....	34
Bibliography.....	37
Appendix A – Rain gauge calibration data.....	38
Appendix B – Methods, detection limits, and quality objectives for water quality testing.....	40
Quality Assurance, Quality Control	43
Water quality sampling methods	46
Water Quality Sampling Procedures	48
Appendix C – Seed and fertilizer specifications	51
Appendix D – Soil profile information	52
Appendix E – Additional construction photos	54

List of Figures

Figure 1. State Route 518 Project vicinity map	9
Figure 2. Layout of project site elements.	11
Figure 3. Site features. Photo source WSDOT Photogrammetry, date taken 3/24/2005	12
Figure 4. Crest gauge.....	14
Figure 5. TB3 (left) and ISCO (right) rain gauges installed in housing in pits	15
Figure 6. Soil corer used for taking soil bulk density samples - source ICT International.....	16
Figure 7. Water poured on the shoulder of SR 518 to determine the contributing area	17
Figure 8. Water flow across the travel lanes from north to south towards curb	18
Figure 9. Instrument box on pad.....	18
Figure 10. TB3 “tipping bucket” rain gauge calibration	20
Figure 11. Excavator used to do site preparation	22
Figure 12. WSDOT employee finishing concrete pad for instrument box	22
Figure 13. French drain trench	24
Figure 14. Instrument box detail and bioswale section	25
Figure 15. Bioswale plan and detail	26
Figure 16. Curb cut and inlet pipe	27
Figure 17. Pea gravel being placed in French drain by an aggregate delivery truck.....	27
Figure 18. Compost blower truck (top) and steel pin showing final compost depth	28
Figure 20. Vegetation on bioswale 1 (left) and bioswale 2 (right) (January 4, 2009)	30
Figure 19. Bioswale 2 (left) and bioswale 1 (right).....	30
Figure 21. Water seeping from sides of ISCO pit.....	31
Figure 22. Bioswale site before construction began.....	54
Figure 23. Bioswale preliminary layout	54
Figure 24. Excavator removing asphalt lining in ditch.....	55
Figure 25. Wood box for TB3 pit rain gauge	56
Figure 26. WSDOT workers installing pipe and plastic sheeting in French drain	56
Figure 27. Bioswale 1 with dam at bottom end and French drains	57
Figure 28. Bioswales ready for compost (bioswale 1) and seeding.....	57
Figure 29. Bioswale with compost blanket installed.....	58
Figure 30. Hydroseeding Bioswale 1 with trailer mounted nozzle.....	58
Figure 31. Hydroseeding Bioswale 2 with hose	59
Figure 32. Hydroseed mixture cover detail September 15, 2008	60
Figure 33. Vegetation establishment in Bioswale 1	60
Figure 34. Parshall flume at inlet to bioswale 2	61
Figure 35. Parshall flume at outlet of bioswale 1	61
Figure 36. Swales with all equipment in place (March 6, 2009).....	62

List of Tables

Table 1. Budget and costs for bioswale installation and 1st year of monitoring	33
Table 2. Hydrologic Services TB3 rain gauge calibration.....	38
Table 3. ISCO rain gauge #2 calibration	39
Table 4. Methods and detection limits for water quality testing.	40
Table 5. Method and quality objectives for water quality data.	42
Table 6. Typical programming parameters for automated samplers.	49
Table 7. WSDOT erosion control seed mix.....	51
Table 8. Soil profile properties for SR 518 site. Soil profile was done on 6/12/2008.....	52
Table 9. Soil description:	52

Introduction

The Washington State Department of Transportation (WSDOT) has responsibility for more than 7000 miles of highways across the state, most with limited right-of-way space. The U.S. Environmental Protection Agency (EPA) through implementation of its National Pollution Discharge Elimination System (NPDES) requires WSDOT to capture and treat stormwater runoff from roads and the right of way before releasing it to receiving water bodies. Runoff from highways contains numerous harmful pollutants including hydrocarbons; heavy metals, such as lead, copper, and zinc; and suspended solids (WSDOT, 2008) .

WSDOT has limited options for meeting end-of-pipe enhanced treatment for stormwater runoff from highways. Recent changes to the NPDES permit that WSDOT operates under have made finding effective end-of-pipe treatments more urgent. Under NPDES I, WSDOT had to provide treatment that removed heavy metals from highway runoff if the average daily traffic counts (ADT) exceeded 10,000 vehicles per day. Under the new permit, NPDES II, the ADT has dropped to 5,000 vehicles a day. This means that there are many more miles of roadway for which WSDOT will need to implement highway runoff water quality mitigation measures to be in compliance with NPDES.

One potentially effective mitigation measure is to divert highway runoff through a compost amended bioswale located in the right of way before discharge from the WSDOT maintained property. This report describes the design and construction of a test site for evaluating the effectiveness of a compost amended bioswale for removing NPDES designated pollutants.

Literature Review

Many studies have shown that compost amended soil removes metals and other pollutants from contaminated water (Barrett et al. 2004; Glanville et al. 2004; Hsieh and Davis 2005; Pitt 1996; Sun and Davis 2007; Yu et al. 2001). However, many of these studies were at sites where the stormwater infiltrated into the soil such as at bioretention ponds, bioinfiltration areas (also known as rain gardens), or side slopes. Yu, et al (2001) studied grass lined swales and concludes that the effectiveness of swales as a best management practice (BMP) is “highly dependent on design characteristics such as length, longitudinal slope, and the presence of check dams.” Filtration by vegetation, settling of particulates, and infiltration into the subsurface zone are the primary mechanisms for pollutant removal (Yu et al. 2001). Barrett, et. al. (2004), found that vegetated filter strips designed to convey highway runoff were effective in removing pollutants from stormwater. The vegetated swales reduced the pollutant mass transport to receiving waters by more than 85% for Total Suspended Solids (TSS), 68-93% for turbidity, chemical-oxygen demand, zinc, and iron, and 36-61% for total organic carbon, nitrate, and total Kjendahl nitrogen (TKN), total phosphorus and lead. Grassy swales without compost were used. Rushton (2001) found that swales reduced average runoff pollutant amounts by 30% in a parking lot setting in Florida.

Mazer, et. al. (2001) report that the abundance of vegetation does not correlate well with pollutant removal in bioswales; hydraulic retention times and flow depth are better indicators of the effectiveness of bioswales to remove pollutant. They indicate that the longitudinal slope of bioswales should be between 0.5 and 2%(Mazer et al. 2001)

Compost added to soil provides organic matter that adds adsorption sites (Rushton 2001; Sun and Davis 2007) and lowers soil bulk density(Pouyat et al. 2002). Organic matter improves soil structure and provides conditions conducive to healthy soil microbes (Rushton 2001). Glanville, et al. (2004), reported significantly greater infiltration capacity on highway embankments where compost blankets had been applied. Persyn, et. al. (2007) found that compost blankets increased the plant mass of planted species while controlling the establishment of weeds on highway slopes. Faucette, et al. (2006), reported that soils receiving compost blankets averaged 2.7 times more vegetation cover than “hydroseed” treatments alone. Because plant cover, soil structure, and water infiltration rates are all enhanced by compost

applications and these factors also play a key role in pollution removal from stormwater, applying a compost blanket to swales ought to increase their pollution removal capabilities.

The available research shows that short lengths (about 30 m) of compost blankets reduce pollutant loading of stormwater runoff. Since most of these studies were done on sites with sheet flow, questions still remain about concentrated flows in swales. For much of the WSDOT system, storms are often of long duration and low intensity. Yu, et. al. (2001) suggest that swales can be highly effective for pollutant removal in this type of situation.

For a compost amended bioswale to be deemed a satisfactory Best Management Practice (BMP) for enhanced treatment of highway runoff by the Washington State Department of Ecology (WSDOE), it must “provide a higher rate of removal of dissolved metals than Basic Treatment facilities.” (O'Brien 2005) The WSDOE *Guidance for Evaluating Emerging Stormwater Treatment Technologies, Technology Assessment Protocol – Ecology (TAPE)* assumes that the facility is treating stormwater “with dissolved copper ranging from 0.003 to 0.02 mg/L and dissolved zinc ranging from 0.02 to 0.3 mg/L”. It further assumes that enhanced treatment is a 50% reduction in dissolved metals over basic treatment with “ $P \leq 0.10$ that influent does not equal effluent”. (Hoppin 2002)

Study Design

Site Selection

Resources were available to construct two highway right-of-way bioswales, one with compost and one without (control), and to monitor them for their effectiveness for removing pollutants from highway runoff particularly metals and fuel and combustion related products. For logistical reasons a single site where this could be accomplished was desirable. The site needed to be representative of worst case factors such as low water infiltration rates into soil and high traffic counts and the best case in terms of safety. To complicate matters, the research site would need to be visited by other than WSDOT staff for installation and maintenance of the equipment. To meet these requirements, the following minimum criteria were developed to screen potential sites.

- Safe access to the site for field personnel
- Sufficient hydraulic controls at the BMP inlet and outlet for flow monitoring
- Soils with low infiltration characteristics
- Medium to high (greater than 5,000) average daily traffic (ADT) counts
- Clear delineation of drainage area that supplies water to the BMP
- Security of sampling equipment at the site
- Topography, and
- Time to establish the site

1. Initial Criteria

Site investigation

Site investigation began with discussions with WSDOT Environmental Services Office and Hydraulics Unit staff and staff from Herrera Environmental (Herrera). Herrera staff were consulted because they are currently under contract with WSDOT to monitor the performance of water quality BMP's and they maintain a database of bioswales along WSDOT roads.

WSOT has many existing unamended bioswales along its roadways so retrofitting bioswales could be a cost effective means to increase stormwater runoff treatment.

Safety

Safe access to the site, worker safety, and vehicle recovery zones are of paramount importance in any WSDOT project. Working alongside high speed traffic is dangerous; safe access to the site by vehicles was a prerequisite. To be as safe as possible, the site needed good visibility from the road so that workers could safely pull off from and reenter the highway. The site approach sight distance had to be long enough for approaching vehicles to allow trucks pulling heavy equipment enough space to get up to speed before entering into traffic. The shoulder had to be wide enough to allow large vehicles to pull entirely off the road and out of traffic. Shoulder closures would be permitted for construction and maintenance with appropriate signs and traffic control measures; however, lane closures were not an option.

Once the vehicles were on the site, worker safety took precedence. The site needed to be big enough to allow for workers to be off the road shoulder when working. The site right of way had to be wide enough to allow any test equipment to be outside the “vehicle recovery zone”. The vehicle recovery zone is the area outside the travel lanes that is free from obstructions that could cause damage to errant vehicles. The intent of the recovery zone is to give drivers of errant vehicles an off pavement area where they can recover control of the vehicle and bring it to a safe stop. The boxes for the data gathering instrumentation would constitute “obstructions” and thus had to be located out of the recovery zone. It was also highly desirable that the constructed bioswales could not be damaged by an errant vehicle. The width of the recovery zone varies by average daily traffic, posted speed limit, and the geometry of the side slopes; thus potential sites had to be analyzed on a case by case basis.

Traffic control is a major safety component, and expense, of any WSDOT project or operation. The amount of traffic control needed depends on the ADT, speed of the traffic, the amount of intrusion into the roadway, and the length of time needed for the work. Generally the less the project intrudes into the roadway and the shorter the time, the less traffic control that needs to be done. Therefore, a wider area to pull vehicles off the road is desirable.

Highway Runoff Supply

Sufficiently large and clearly identifiable pavement runoff contributing domains are needed to supply runoff to two receiving bioswales. The minimum dimensions of the bioswales required supply from a paved surface contributing area of approximately 5000 ft² or larger. This became one of the hardest criteria to meet successfully and the site requirements for hydrologic monitoring became one of the most limiting factors.

Roadway geometry, superelevations, and the road crown's influence on directing water movement across the pavement were investigated carefully to determine which section of roadway was actually contributing to the site. Because this project was to test end-of-pipe treatments, it was important to find a site where water was delivered directly from the roadway and had not been pretreated in any way. The best way to do this is to have a section of roadway that has a curb to channel the water to pipe inlets. Curbs can be cut to direct flow to the treatment site and inlets can be blocked temporarily for the duration of the research project. By cutting curbs at predetermined spots, the contributing area can be defined. Non-curbed sections were investigated, but it is more difficult and expensive to build curbs, so a curbed section was preferable.

In several past WSDOT studies the findings were ambiguous because water in addition to that from the paved area was delivered to treatment zones. In some cases it was overland flow and in others it was ground water inflow that skewed the results. Thus it was imperative that the bioswales be isolated from any other inputs (excluding direct precipitation), not only from the roadway, but from side slopes and other drainages.

Soils

The right of way soils were required to have very low infiltration rates. The reason for this restriction was that if a compost amended bioswale was placed above a low infiltration soil and it was effective, it would be effective in more permeable soils as well. Soils with a United States Department of Agriculture (USDA) hydrologic soil rating of C or D were preferred.

Topography

WSDOE requirements specify minimum water retention times in bioswales used for pollutant removal. These requirements are incorporated directly in the WSDOT Highway Runoff Manual. The topography of the site is important because the maximum allowed slope of bioswales is 5% and the maximum velocity of the water is 1 foot per second (WSDOT 2008). In addition, a minimum hydraulic retention time (HRT) of 9 minutes and a minimum swale length of 100 feet are required. These requirements and recommendations of Mazer et al (2005) that right of ways where bioswale slopes of 2% could be constructed were preferred. For ease of construction and to minimize earthwork, it was desirable to have the existing slope be a close to the final slope as possible. The site had to be at least 250 feet long to accommodate two 100 feet long swales and the room needed to install the flumes and pipes required for flow rate measurement and water quality sampling.

Traffic

Average daily traffic (ADT) is one of the many measures that WSDOT uses to characterize its roads. Stormwater treatment levels are also tied to ADT insofar as the treatment levels are more stringent with higher traffic counts because, in most cases, the higher the ADT the higher the pollutant loading will be. Sites that had ADT counts of over 10,000 vehicles per day were desirable; sites with higher ADTs involve more traffic control because of safety issues. Consequently sites on busier highways such as Interstate 5 were not considered.

Time Line

Since it would take up to three years to gather sufficient data to satisfy WSDOE requirements to demonstrate the effectiveness of the proposed mitigation measure, it is imperative that the site not be disturbed by planned future projects. The three year timeline is a minimum. It is preferable to have a site with no future projects planned so that the bioswales could be kept in place and monitoring could be resumed in later years if needed to determine how performance changes over time.

2. Initial criteria vs. final criteria

Many potential sites along State Route (SR) 18 were investigated. There were several sites that initially seemed likely candidates, but all but two failed to meet the site selection criteria.

WSDOT maintenance staff members were contacted to obtain additional information about the sites. They pointed out that the sites had a very free draining soil which was not apparent from the initial field review. The maintenance staff suggested some locations that they knew of with tight soils that might also fit our criteria. The sites were along SR 518 and SR 167. These highways were well suited for the study because they had adequate right-of-way in most cases and the ADT counts were low enough that excessive traffic control measures would not have to be used.

Locations in the vicinity of mile post 8.47 on SR 167 and mile post 1.29 on SR 518 were investigated. The site on SR 167 appeared promising at first because it was relatively flat. However, this section of the highway did not have curbs so the water sheet flowed directly into the existing swales. Also the site was surrounded by wetlands and there was some concern that there might be some intrusion from groundwater into the swales that would affect the results.

The site on SR 518 that the maintenance staff recommended is in the median at mile post 1.29. The site is large and relatively safe and the soils were mapped as Alderwood soils on the King County soils map. The site had broad asphalt lined ditches that the maintenance staff had considered removing and turning into grass lined ditches. This site was examined in considerable detail and ultimately chosen. A general location map is provided in Figure 1.

The layout of the anticipated site elements including the drainage areas, bioswales, instrumentation, and recovery zone is shown in Figure 2. The bioswales would be placed in the median which was about 80 feet wide and there was a guard rail on the uphill side (west-bound lanes). The highway on the uphill side drained toward the median and there was curbing under the guard rail. The curbing channeled the runoff into inlets that drained via metal pipes into the existing asphalt lined ditch in the median. By plugging the inlets and pipes and cutting the curbs, highway runoff could be controlled and easily routed from the road to the planned bioswales.

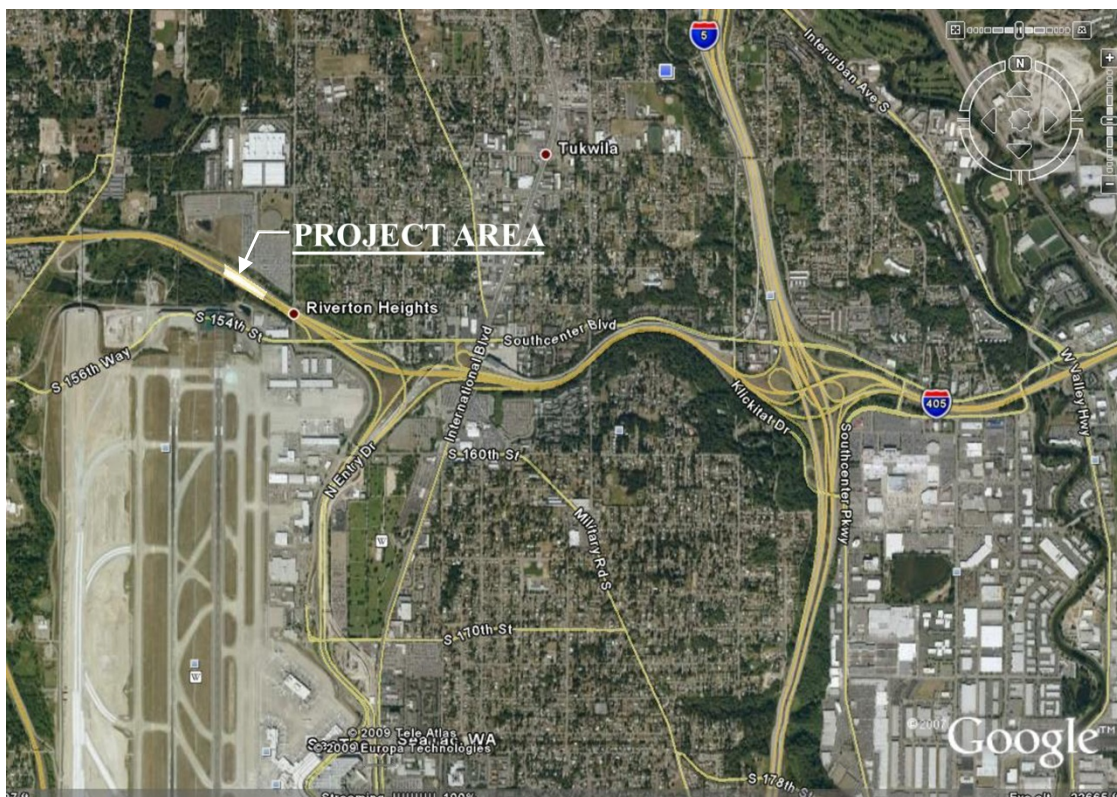

Figure 1. State Route 518 Project vicinity map

Another advantage of this site was the availability of electrical power. Vandalism and theft are always concerns for these types of projects because of the expensive equipment needed for the data collection. This location, because of its more urban setting compared to sites on SR 18 or SR 167, has light standards and a lighted sign bridge adjacent to the site. The availability of electricity meant that it could be used to charge the batteries to run the equipment rather than using solar panels. Solar panels are particularly prone to vandalism and theft because they cannot be enclosed in strong boxes like the other instruments.

The closest the bioswales would be to the edge of the road shoulder is 26 feet (east bound lanes). The shoulder on the median side of the roadway is 12 feet wide, thus the closest the bioswales would be to the travel lanes is 38 feet. There was space on the uphill side of the bioswales to install the instrument boxes. Thus the instrument boxes would be at least 53 feet from the east bound travel lane and not constitute an “obstruction” for errant eastbound vehicles; this is well outside the designed “recovery zone” for this section of roadway.

Site Analysis

The SR 518 site appeared to meet all spatial, safety, and slope criteria, so a more detailed analysis of the site was undertaken. A soil pit was dug to characterize the soil. A hand auger was used to test the soil at 10 foot intervals along the axis of the planned bioswales. The auger was drilled into the soil until it reached a layer that it could not penetrate. Soil was pulled to the surface with the auger and examined visually. The soil that was pulled up with the auger looked similar to that taken from the soil pit. The soils are dense with a basal till horizon from 8 inches to 24 inches below the surface. See Appendix D and Table 8 for soil profile information.

The longitudinal slopes in the zone where the two 100 feet long bioswales were to be constructed ranged from about 2 to 6 %. The bioswales would be constructed to replace the asphalt lined ditch and they could be constructed with minimal regrading and disturbance of the site

Design and Construction of Bioswales and Monitoring System

The site is located at mile post 1.29 on State Route 518 in the city of SeaTac in King County Washington (Figure 1, and Figure 2). According to the WSDOT Data Office, the average daily traffic for this section is 27,600 vehicles per day in the west bound lanes. Figure 3 shows to scale a plan view of the actual facilities.

The test facility contains two bioswales, each 100 feet long by 6.5 feet wide, on WSDOT right of way. The bioinfiltration swales were designed according to Section 5-2.2.3 of the WSDOT Highway Runoff Manual (HRM). Both bioinfiltration swales were constructed using native soils. Bioswale 1 included a three inch deep compost blanket. The compost conformed to WSDOT Standard Specification 9-14.4(8) for coarse compost and was obtained from Cedar Grove Composting, Maple Valley, WA. Bioswale 2 serves as a control.

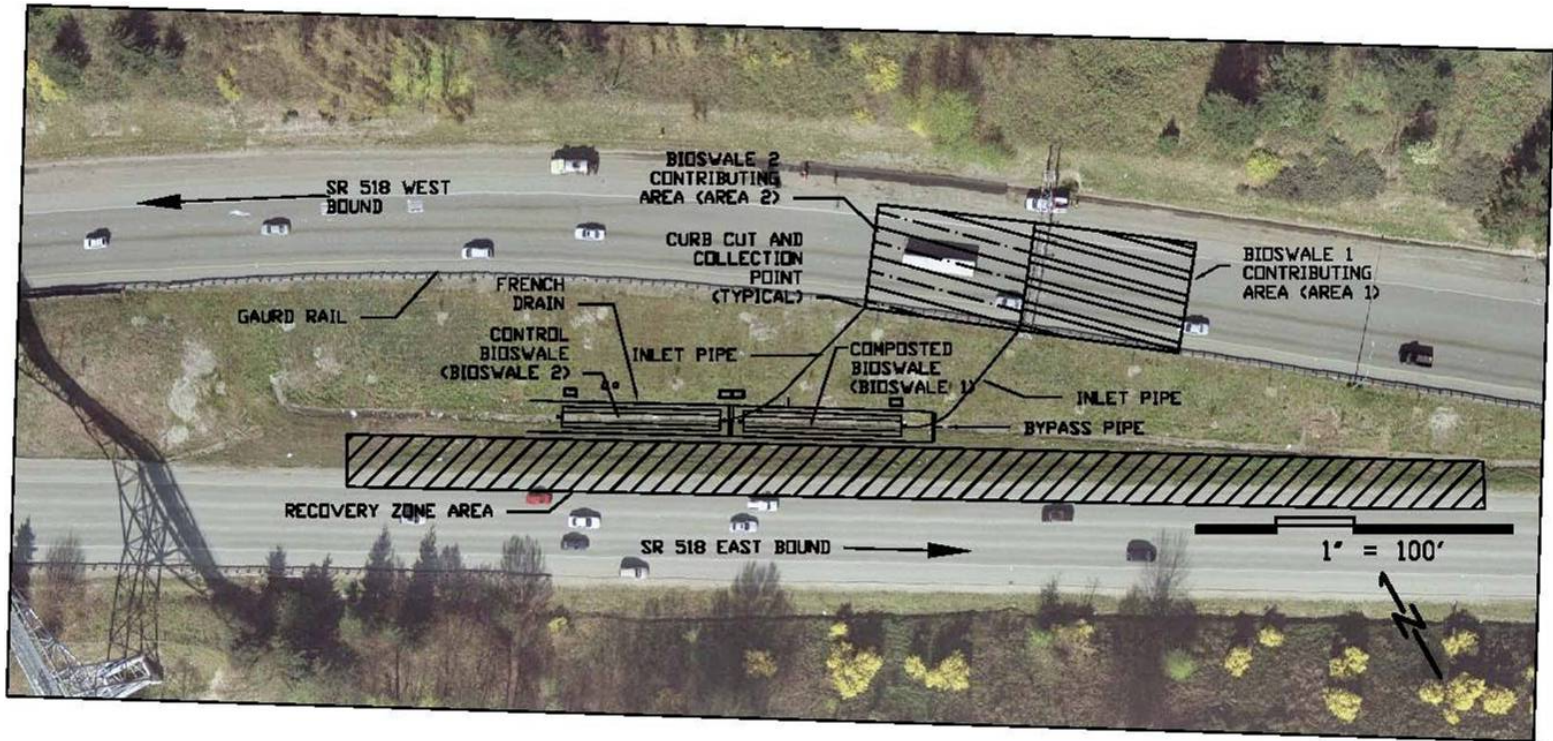

Figure 2. Layout of project site elements. (See Figure 3, Figure 14, and Figure 15 for more detail.) Map source WSDOT Photogrammetry, photo taken 3/24/2005

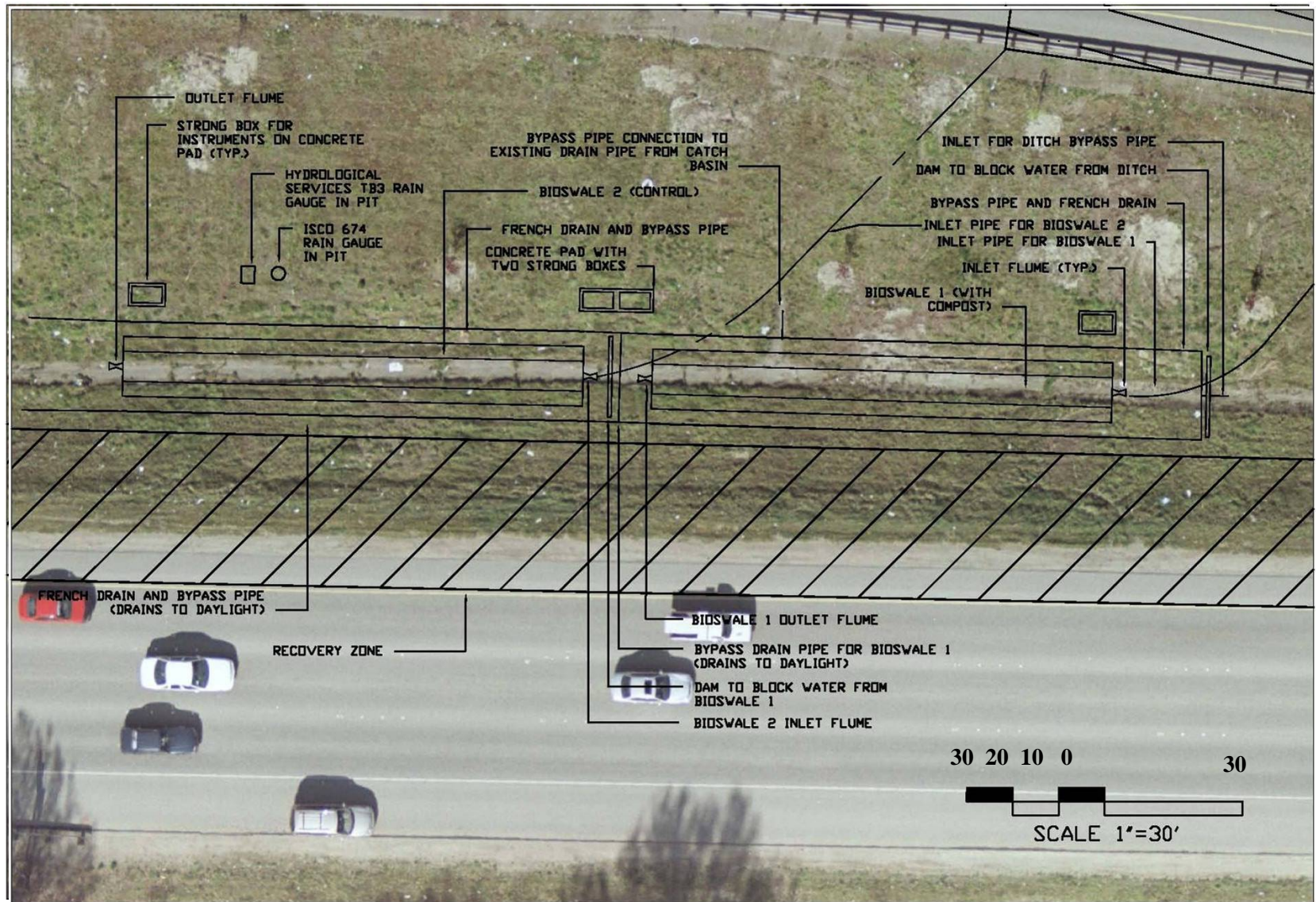

Figure 3. Site features. Photo source WSDOT Photogrammetry, date taken 3/24/2005

Both bioswales were hydroseeded with a WSDOT erosion control seed mix that consists of *Festuca rubra L.ssp. rubra* (creeping red fescue), *Alopecurus pratensis L.* (meadow foxtail), *Trifolium repens L.* (white dutch clover), and *Agrostis castellana* (Highland colonial bentgrass) at a rate of 8 pounds per 1000 square feet (see Appendix C). Fertilizer was added to the hydroseed mix for the control section at a rate of 3 pounds per 1000 square feet (see Appendix C). The compost section did not receive additional fertilizer in the hydroseed mix.

Stormwater runoff from the westbound lanes is captured at a curb cut and piped to the inlet of the swales via 4 inch PVC pipes. The contributing area consists of 100 feet of three 12 feet wide travel lanes, and two 10 feet wide shoulders, for a total of approximately 5600 square feet for each swale. Area 1, shown in Figure 2, is the contributing area for bioswale 1 and Area 2 in Figure 2 is the contributing area for bioswale 2.

Three-inch (throat dimension) Parshall flumes and Druck 1830 pressure transducers at the inlet of the swale are used to determine the quantity of water entering the swale. ISCO automatic samplers located at the inlet will obtain water quality samples at predetermined times throughout the storm when the flow is large enough.

Three water level “crest gauges” per swale are used to determine the maximum depth of flow in the swale per storm and to determine if the maximum depth is consistent along the length of the swale. The crest gauges are tubes with cork dust and an inlet in the bottom. As the water rises in the gauge the cork dust floats on top and leaves a ring on the inside at the maximum depth. After each storm the gauges will be read and the peak water level noted. A small amount of water is used to wash the dust down to reset the gauge (See Figure 4).

Two piezometers permit manual sampling of near-surface groundwater immediately below each swale. These were placed about two-thirds of the way down the swale at depths of one foot and two feet. The purpose of these wells is to quantify movement of pollutants into the subsurface.

One-inch (throat dimension) Parshall flumes and Druck 1830 pressure transducers placed at the end of the swale are used to measure the outflow flux. An ISCO automatic sampler will obtain water quality samples from the outflow flume. The flow rate data will be used to determine the



Figure 4. Crest gauge

water mass balance for each swale. The water quality samples will be used in conjunction with the flow rate data to determine the pollutant mass balance for the bioswale

Three rain gauges are used to determine the rainfall amount on the site. Two gauges are placed in pits flush to the surface of the ground and the third is mounted on a pole 6 feet above ground. Two of the gauges, one in a pit and one on the pole, are ISCO Model 674 and the second pit gauge is a Hydrological Services TB3. Campbell Scientific CR 1000 dataloggers are used to gather data from the transducers and the rain gauges.

The TB3 rain gauge is housed in a treated lumber box that allows room for the rain gauge and an accumulating bucket that is used to check the volume of water that passes through the tipping bucket gauge (Figure 5). The ISCO rain gauge is housed in a well-drained plastic 5 gallon bucket. Both rain gauges have leveling bubbles incorporated into the instrument bodies. The TB3 is mounted on 3 stainless steel rods set in concrete and the ISCO rain gauge is bolted to the bottom of the bucket. The bucket sits on a concrete pad at the bottom of the pit. Native soil is used to backfill around both housing units. A frame covered with home heating furnace air filter fabric is used to prevent water from splashing into the rain gauges. Both pits have a drain pipe leading from the bottom of the pit to a down gradient French drain to facilitate drainage.



Figure 5. TB3 (left) and ISCO (right) rain gauges installed in housing in pits

The bioswales are isolated from surface and groundwater flows from the rest of the site by French drains. Other water from the ditch above the site and from inlets from the highway is routed around the bioswales by solid drain pipes.

Washington State Dept. of Ecology Requirements

The test methods and handling procedures are based on requirements necessary to meet the Guidance for Evaluating Emerging Stormwater Treatment Technologies, Technology Assessment Protocol - Ecology (TAPE) protocol. The Washington State Department of Ecology (WSDOE) is the agency charged with administering the Clean Water Act in Washington State and has approval authority over new stormwater treatment methods. Following the TAPE guidelines will allow WSDOE to assess this project for acceptance as a best management practice (BMP) for treating highway stormwater runoff.

A Quality Assurance Project Plan prepared by the author has been filed with WSDOE and is awaiting approval. The plan details all the design, sampling, and testing parameters of the research project. Full details for methods, detection limits, and quality objectives for water quality testing; Quality Control and Quality Assurance; and water quality sampling procedures are provided in Appendix B – Methods, detection limits, and quality objectives for water quality testing.

Methodology

Soil Testing – Determination of bulk density

An in-situ soil bulk density test was performed on the Bw2 and C soil horizons (Table 9). A soil impact corer was used to remove a sample from the Bw2 horizon. The impact corer is held perpendicular to a soil horizon and a weighted hammer is used to drive the corer into the soil. The corer is made up of an outer solid ring with a sharp edge. Inside the outer ring are 5 brass rings that slip out of the outer ring. The inner rings hold the soil. The three rings on the end of the core are removed and the soil is struck off across the faces of the two inner rings. (Figure 6) The soil from the two middle rings was placed in a sample bag and marked for further processing.



Figure 6. Soil corer used for taking soil bulk density samples - source ICT International

The soil in the C horizon was too hard to use the soil corer so an alternative method was used to determine bulk density. In this case the bottom of the pit was made as level and free of loose soil as possible. Next a small hole was dug in the bottom of the pit and all the soil from the hole was carefully collected and placed in a sample bag. Next a sheet of thin plastic that would easily conform to the contours of the hole was

placed over and in the hole. A 1000 ml graduated cylinder was filled to 1000 ml and water was carefully poured into the hole until the water filled the plastic lined hole. The volume of water remaining in the graduated cylinder was recorded. The in-situ volume of the soil that had been removed was determined by subtracting the volume of water remaining in the graduated cylinder from 1000 ml.

Both soil samples were taken to the WSDOT Materials Lab in Tumwater where they were oven dried for 24 hours at 70° C. After drying the samples were weighed and the bulk density

was determined by dividing the weight by the volume. The bulk density of the soil was 116 lbs ft⁻³ (1859 kg m⁻³) for the Bw2 horizon and 105 lbs ft⁻³ (1679 kg m⁻³) for the C horizon.

Vegetation monitoring

The vegetation in both bioswales will be monitored to determine if there are differences between the two treatments and how the vegetation changes over time. Vegetation-soil “plugs” will be taken from each bioswale to determine above ground biomass, below ground biomass, and total biomass. A systemic random method will be used to determine the location of the plugs in each bioswale (Nature Conservancy, 1999)

In addition to the biomass sampling, photo plots will also be established to record the changes in the vegetation over time. Vegetation sampling will occur at 6, 9, and 12 months and yearly after that through the duration of the monitoring program.

Measuring water

contributing area

Determining the paved area that contributes water to the bioswales was critical to the design of the bioswales and the study design. The site investigation team examined the grades on the site to determine what part of the roadway was draining to the curb. This was a crude way to describe the drainage area at best so

the as-built plans for the roadway were located at the WSDOT plan archives. Upon studying these files it appeared that the grading plan on the sheets did not match the site.

A simple test was undertaken to determine which way the water flowed on the road. Water was poured on the shoulder to see which way it would flow. (Figure 7) It immediately flowed south



Figure 7. Water poured on the shoulder of SR 518 to determine the contributing area



Figure 8. Water flow across the travel lanes from north to south towards curb

across the shoulder and toward the travel lanes. Water was slowly added to the stream and it continued to flow across the travel lanes toward the curb on the south side of the highway. (Figure 8) This test was repeated at the beginning and the end of each contributing area with the same results in each case.

Measuring runoff inflow and swale outflow

Each monitoring station is equipped with an ISCO automated sampler that is housed in a vandal-resistant and waterproof metal enclosure (Figure 9). Flow rates are measured by routing the water through flumes at the inflow and outflow of each bioswale. Water depth is measured with pressure transducers located in stilling wells at each flume.



Figure 9. Instrument box on pad

Power to the automated samplers and flow-measurement devices is maintained by a rechargeable battery that is connected to the highway lighting system. The batteries will be recharged whenever the lighting system is

operating.

The automated samplers at each monitoring station are programmed to log readings from the flow-measurement devices at 5-minute intervals over the duration of each storm that is targeted for sampling. After each storm, data from the automated samplers will be uploaded in the field using a laptop computer or remotely using the “Raven Cell” links. Automated field data will be downloaded to a computer network in the consultant’s offices where it will be stored and managed using the ISCO Flowlink software program. These data will be backed up to a secure location daily. As necessary, these data will also be exported to other software programs (e.g., Microsoft® Excel, Microsoft® Access, SPSS®, and/or Statistica®) to facilitate analyses and reporting.

Precipitation

Three rain gauges have been installed near the bioinfiltration swales. Two rain gauges were installed at ground level in pits and the third on a pole at a height of 6 feet. Accumulated water from one pit gauge (TB3) will be collected to check against the indicated rain depth yielded by the counted tips from the gauge “tipping bucket”. These rain gauges are interfaced with the automated samplers at each station. The automated samplers are programmed to log tips from the rain gauges throughout the duration of each storm that is targeted for sampling. Data will be uploaded and stored as detailed in the previous section.

Equipment calibration

All three rain gauges were calibrated using a Hydrological Services TB320 Mariott Tube Field Calibration Device, (Figure 10). The TB320 delivered a known quantity of water at a steady rate to the rain gauge. A Hobo ® event counter recorded the number of “tipping bucket” tips that occurred during the test. The calibration was repeated at least five times for each flow rate. The Hydrological Services TB3 rain gauge was calibrated at equivalent rain rates of 50 and 100 mm h⁻¹ and the ISCO gauges were calibrated at flows of 4.7, 5.1, and 19.2 mm h⁻¹. Calibration details are given in Appendix A.

Each of the “Druck” pressure transducers was calibrated for precision and bias using the following procedure:

Test 1 – Vary water levels

- Place the transducer into a 2 feet tall graduated measuring cylinder
- Fill cylinder with 1 foot of water
- Seal cylinder tightly to reduce or eliminate evaporation (leave a small hole for pressure equilibrium)
- Zero the transducers
- Run the test for 48 hours taking readings at 5 minute intervals
- Repeat test at 1.5 feet depth without rezeroing the transducers between tests

Test 2 – Colder Temperatures

The test for colder temperatures was done in the same manner as Test 1 except that the cylinders were stored in a refrigerator for the duration of the test.

The 48 hour test interval was chosen because in most cases the maximum length of



Figure 10. TB3 “tipping bucket” rain gauge calibration with a Hydrological Services TB320 Field Calibration device and a Hobo event recorder

storms that would be monitored is less than 48 hours. Transducer calibration was performed by the consultant's staff.

Water quality testing

The laboratory analysis of collected water quality samples will be performed according to methods that are approved by the U.S. Environmental Protection Agency (EPA) (APHA et al. 1992; U.S. EPA 1983, 1984). These methods provide reporting limits that are less than the state and federal regulatory criteria or guidelines and will allow direct comparison of the analytical results with these criteria. The preservation methods, analytical methods, reporting limits, and sample holding times are presented in Table 4 and Table 5, located in Appendix B.

Samples for analyses that require filtration (i.e., dissolved copper and dissolved zinc) will be delivered to the laboratory within 24 hours of the collection time of the last aliquot. Upon their receipt, laboratory personnel will immediately filter and preserve the samples.

The laboratories identified for this project are certified by WADOE for the targeted parameters in this study and participate in audits and inter-laboratory studies by WADOE and the EPA. These performance and system audits have verified the adequacy of laboratory standard operating procedures, which include preventive maintenance and data reduction procedures.

The laboratory will report the analytical results within 30 days of receipt of the samples. The laboratory will provide sample and quality control data (e.g., laboratory blanks, matrix spikes, laboratory duplicates, and laboratory control samples) in standardized reports that are suitable for evaluating the project data. The reports will also include a case narrative summarizing any problems encountered in the analyses.

Site Preparation and Equipment Installation

The bioinfiltration swales were constructed in late summer 2008. Monitoring will begin in April 2009 when the vegetation in the bioswales is sufficiently established to prevent erosion and all equipment is installed and operational. Monitoring will continue until sufficient samples are acquired to meet the WADOE TAPE protocol.

The site was constructed by WSDOT maintenance crews under the supervision of the author. Construction began by laying out the bioswales and equipment pads to make sure everything



Figure 11. Excavator used to do site preparation

would fit on the site. After the layout was complete, equipment was brought in to prepare the site. A John Deere D50 excavator with a 6.5' wide blade was used to prepare the pads for the equipment, dig the trenches, and construct the bioswales (Figure 11). A laser level was used to control the slope of the bioswales.



Figure 12. WSDOT employee finishing concrete pad for instrument box

Portland cement concrete pads were installed for the equipment boxes. Two inch conduit was installed in the pads to allow electrical wiring, cables, and tubing to enter through the bottom of the equipment boxes. (Figure 12) Two conduits were installed per box.

Later, the boxes were

installed by the consultant's staff and bolted to the pads. The bolts were installed through the bottom of the boxes so that they could only be unbolted from inside the box and thus prevent theft when the boxes were locked. (Theft from WSDOT field sites is a major problem. One of the boxes was stolen before the locks were installed. Another box was stolen after the locks were installed. The thieves drilled out the lock to open the box.)

The asphalt lining the existing ditch (see Appendix D, Figure 24) was removed and hauled away to a WSDOT maintenance area. The slope of the site exceeded the design finish slope of the bioswales necessitating moving some of the soil had from the upper part to the lower part of the swale.

The design cross-section and centerline level of the swale was checked every 5 feet using a laser level and a rod. Small irregularities were fixed by hand work with shovels, garden rakes, and asphalt rakes. The 3H:1V side slopes were created after the bottom of the swale was positioned correctly. This was done roughly at first by using the excavator with a wide, smooth (no teeth) bucket. Hand tools were used to finish the work. Both the bottom of the swale and the side slopes were compacted by pressing the flat back of the bucket perpendicular to the surface. In addition, the bottom of the swale was compacted by the excavator treads.

The trenches for the French drain and pipes from the curb cuts to the bioswales were made with the excavator using a narrow bucket. The trenches for the French drain were dug, at a minimum, to the top of the basal till layer, or two feet, whichever was deeper. The trenches for the pipes and electrical conduit were a minimum of 2 feet deep to meet local building codes for minimum cover for electrical conduit. (Figure 13)

The trenches for the French drains were lined with plastic on the bottom and bioswale (inside) sides. The top of the plastic was draped over the mounded soil from the trench excavation on the bioswale side of the trench and covered with additional soil to hold it in place (Figure 13). Conduit for electrical pipe, a 4 inch diameter perforated pipe, and a 6 inch diameter solid drain pipe was placed in the trenches on the instrument side of the bioswale and a 4 inch diameter perforated pipe and a 6 inch diameter solid drain pipe were placed on the opposite side of the bioswales (Figure 13).



Figure 13. French drain trench with plastic sheet lining, perforated (black) and soild pipe (light), and electrical conduit installed

water that may be generated by the non-test road section.

The plastic sheeting was placed in the trench to keep any surface or subsurface water from moving into the bioswales other than what is delivered by the inlet pipes or rain falling directly onto the bioswale. The perforated pipe intercepts and carries away any surface or subsurface flows that accumulate in the French drain. The solid drain pipe collects any water from the ditch upslope of the bioswale and any water that is delivered to the site from the existing metal pipes connected to the drain inlets on the roadway. In this way the bioswale is isolated from any ground water or surface

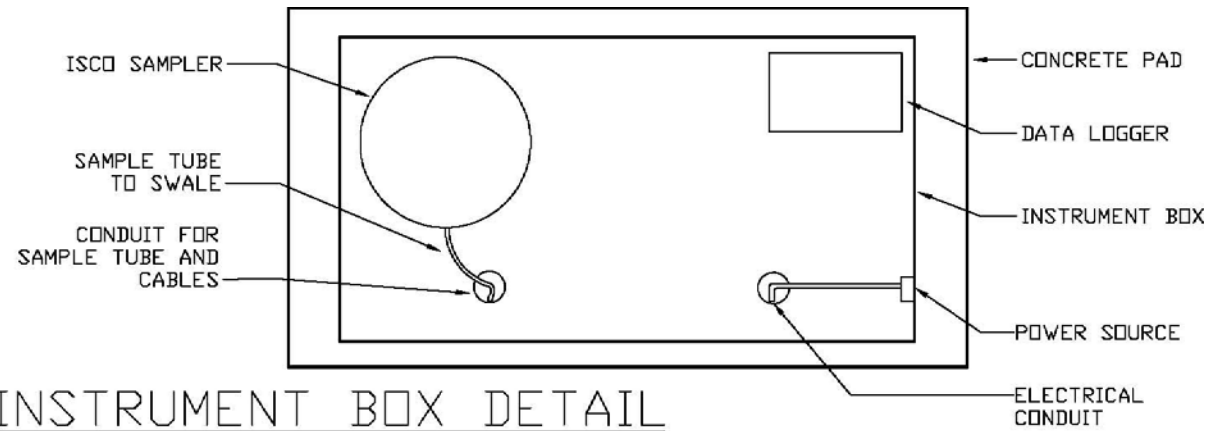

INSTRUMENT BOX DETAIL

NOT TO SCALE

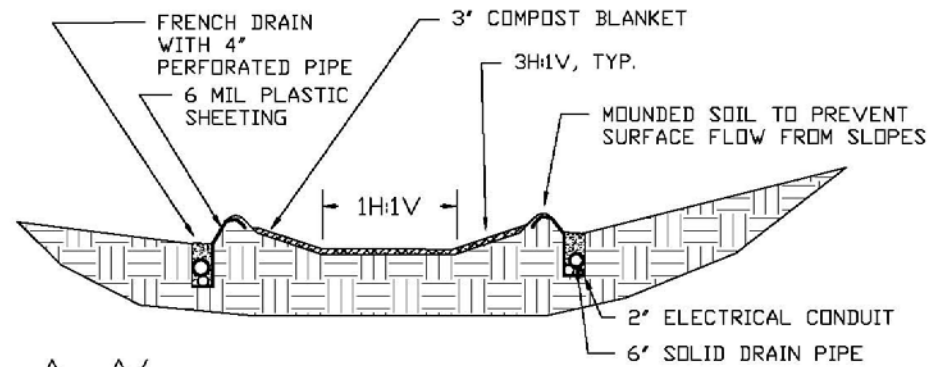

SECTION A-A'

NOT TO SCALE

Figure 14. Instrument box detail and bioswale section

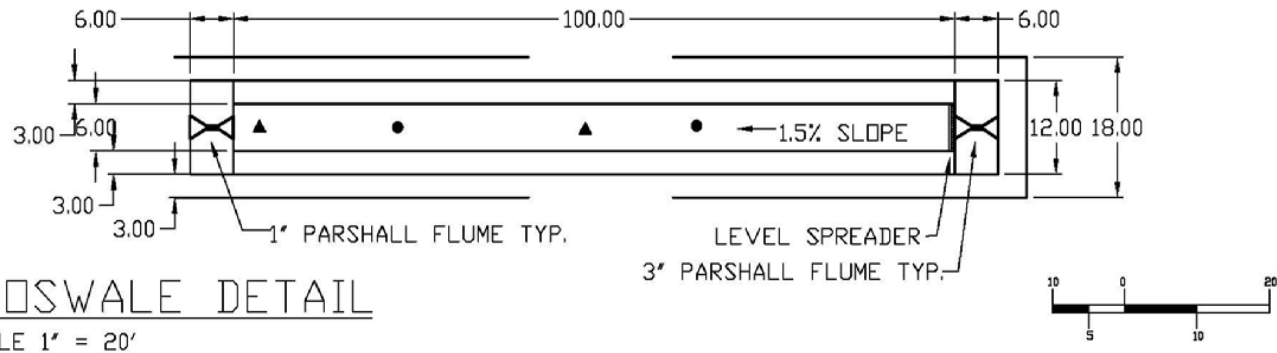
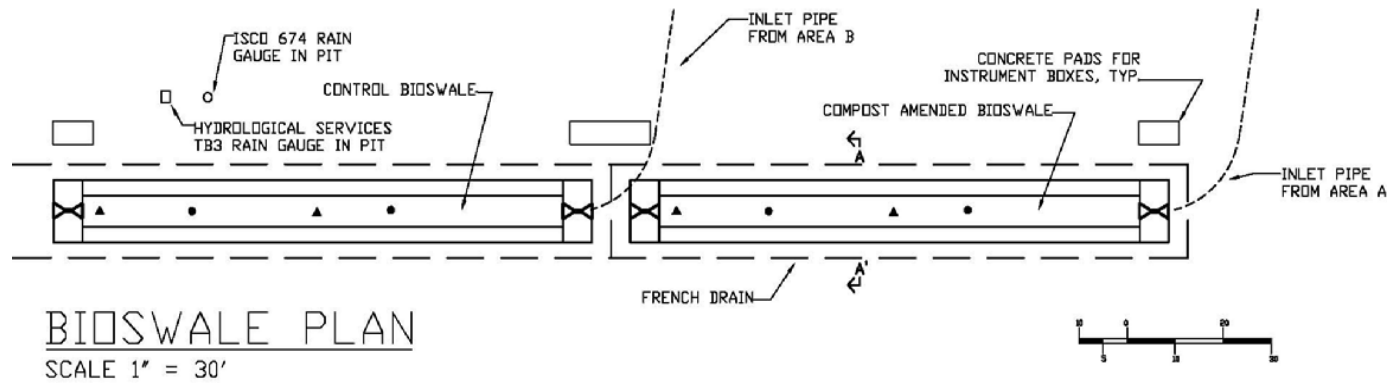

- LEGEND
- ▲ PIEZOMETER
 - CREST GAUGE
 - ⌞ FLUME

Figure 15. Bioswale plan and detail

The curb on the south side of SR 518 was cut in two places to create an inlet for the water to flow into each of the two pipes that feed the bioswales. A concrete pad was made behind the curb cut and a 4 inch diameter solid “schedule40” PVC pipe was embedded flush with the bottom of the pad. A concrete curb was built on the pad to funnel water to the pipe. Each pipe



Figure 16. Curb cut and inlet pipe with temporary cap removed and flow blocking sandbags in place

was fitted with a removable cap and sandbags placed in front of the inlet to prevent water from flowing into the pipe until the site was ready to receive the stormwater flows. The existing catch basins were covered and the sandbags and cap removed on March 15, 2009 when the bioswales were ready to receive water (Figure 16).

Permeable “pea gravel” fill was supplied to the trenches using an aggregate delivery truck with a conveyor belt to place the gravel (Figure 17). An alternative option was to bring the gravel in with dump trucks and place the gravel with a front end loader. This truck placed the pea gravel



Figure 17. Pea gravel being placed in French drain by an aggregate delivery truck

from the shoulder of the road and eliminated any need for repeated trips across the site with the loader.

When the earthwork, French drains, and inlet pipe installation were completed a 3 inch deep blanket of compost was applied to the bottom and side slopes of the upper bioswale (bioswale 1). The compost was placed using a blower truck that also delivered the compost to the site. Steel pins with white markings were placed in the bottom of the bioswale to mark the three inch depth (Figure 18).

After compost placement the site was hydroseeded with a standard WSDOT erosion control seed mix (Appendix B) at a rate of 8 pounds per 1000 square feet. Fertilizer was not added to the hydroseed mix used on the composted bioswale (bioswale 1). Fertilizer was added to the hydroseed mix (Appendix B) at a rate of 3 pounds per 1000 square feet for the “control” bioswale (bioswale 2).

WSDOT electricians installed wiring needed to charge the batteries. This entailed tapping into the power at the sign bridge and installing a transformer to step the power down from 240 volts to 120 volts and then running wires from the transformer to the instrument boxes and installing receptacles.

Herrera Environmental was hired to install the monitoring equipment including the instrument boxes, flumes, pressure transducers, auto-samplers, data-loggers, and the above ground rain gauge. This work was carried out from September 2008 until February 2009. Final installation was delayed by the long lead time needed to obtain the



Figure 18. Compost blower truck (top) and steel pin showing final compost depth

flumes and due to weather.

Additional construction photos are provided in Appendix E.

Initial Vegetation

The vegetation establishment on the two bioswales is noticeably different. Figure 19 shows the control bioswale and the composted bioswale side by side. The vegetation on the composted bioswale is denser and taller than the control (Figure 20). It is clear from these photos that the vegetation establishment has been enhanced by the addition of compost.



Figure 19. Bioswale 2 (left) and bioswale 1 (right)



Figure 20. Vegetation on bioswale 1 (left) and bioswale 2 (right) (January 4, 2009)

Observations supporting the Need for French Drains and Drains for Pit Rain Gauges

While digging the hole for one of the pit rain gauges water was observed seeping from the sidewalls of the hole and collecting on the bottom of the pit. The seepage is evident Figure 21.

While the rate of seepage was difficult to determine, the level in the bottom of the pit rose approximately one inch in less than 30 minutes. The photo was taken on January 4, 2009. The rain gauge at the Seatac airport (0.6 miles away) reported 0.58 inches of rain in the preceding 24 hours that ended at 11:53 GMT (0353 hours local time) January 5, 2009. Previous to that the Seatac rain gauge reported 0.04 inches of rain in the 24 hours preceding 11:53 GMT on January 3, 2009.

This seepage is instructive in two ways. First it shows the need to place a drain in the pit to avoid water build up that could back into the rain gauge, but more importantly, it shows why the French drain is important around the bioswale to keep the water

from seeping from the hillside into the bioswale. Unknown subsurface flow contributions were anticipated during the design phase of the work because of this problem in other research and BMP monitoring sites.



Figure 21. Water seeping from sides of ISCO pit

Monitoring Schedule

Initial test monitoring will start in April 2009. Thereafter monitoring will be conducted on a water year basis beginning in October and continuing through September of the following year. The results of the monitoring will be summarized in annual report that will present the data collected during each water year (October 1 through September 30).

Budget and Costs

The budget for the bioswale installation and monitoring is shown in Table 1. The “state force work” includes the site preparation, supplies (pipe, concrete, pea gravel, electrical conduit, wire, seed, fertilizer, and mulch) and labor costs. Instruments and installation, monitoring and lab analysis, quality assurance/quality control, project management and administration are items provided by the consultant.

Table 1. Budget and costs for bioswale installation and 1st year of monitoring

Cost	Item
\$26,000	Instruments and installation
\$51,000	Monitoring and lab analysis (one year, 12 storms)
\$9,000	Quality Assurance/Quality Control
\$8,000	Project Management and Administration
\$25,000	State force work (site preparation and supplies)
\$119,000	Total for installation and one year’s monitoring

Costs do not include design time, site selection, and equipment calibration performed by the author. It is anticipated that an additional 2 to 3 years of monitoring will be required to obtain enough data to satisfy the WSDOE TAPE requirements. This amount of monitoring will add approximately \$100,000 to the total cost.

Because of the cost, WSDOT cannot afford to install additional bioswales at this time. However, if the composted bioswale is successful in removing dissolved metals to meet the “enhanced treatment” criteria, WADOE will likely allow WSDOT to install and monitor additional sites as a part of regular construction projects. In this way WSDOT will be able to gather more data on this system in different locations around the state with just the additional cost of monitoring and reporting.

Summary and Conclusions

Designing and instrumenting a test site to determine the effectiveness of an experimental highway runoff stormwater Best Management Practice (BMP) is a complex undertaking. From site selection through site design and installation there are many challenges that must be understood and resolved. For this new BMP a bioswale site with a basal till layer was required because of its low infiltration rate. Worker safety was paramount because WSDOT and consultant staff will be on site many times over the life of the project. An additional requirement was that the vehicle traffic count had to be above 7,500 cars per day.

It is crucial to understand Washington State contracting laws and policies before undertaking any project of this kind. In this case the proposed method of identifying and hiring the consultants to do the monitoring was questioned just before construction was to begin. Because of this the monitoring portion of the project had to be put out for competitive bids. Even though the process was fast tracked it added more than one month to the time for ordering monitoring equipment for the site. This time lag pushed out the installation of the equipment into the fall which is normally the start of the rainiest time of the year and delayed the start of monitoring by several months.

A project of this type, especially for a state agency, requires considerable coordination. Four WSDOT offices were involved including the Design Office, Environmental Services Office, Research Office, and the Northwest Region Area 4 Maintenance Office. In addition, the Department of Ecology's Water Quality Division was consulted for design guidance and legal and testing requirements. Close coordination was also required with the consultants who tested and installed some of the instrumentation.

As with any construction project there are contractors and suppliers to coordinate so that the project flows smoothly. Since WSDOT maintenance staff did the bulk of the site preparation, there was no general contractor. That meant that purchasing materials, ordering and coordinating the delivery of commodities such as concrete, gravel, and compost had to be done as the project progressed.

The original plan was to do the site work in August of 2008 so that the consultant's staff could install the monitoring equipment before the water year began in October. As the autumn progressed the weather became much more of an obstacle to completion than any other factor.

There were several large rain storms as well as a cold snap and accompanying snows over several days that stopped work on the project. Pushing the work into the autumn was problematic in another way as well, the staff who were installing the equipment were needed at other sites that were being monitored to repair and program equipment and collect samples. This pushed the planned commencement of monitoring from the autumn of 2008 to the spring of 2009. Whenever possible, construction of these types of facilities should be scheduled to take place starting in June or July to allow for time overruns.

Time lags due for procuring equipment need to be taken into account. The project schedule assumed that the equipment would be delivered within 4 weeks of ordering. However, some of the equipment took over 8 weeks from ordering to arrive. Rather than relying on past experience, determine the time needed to manufacture and ship the equipment when preparing the schedule.

Calibration of the monitoring equipment, flumes, transducers, and rain gauges, is time consuming but critical to the success of any monitoring project. Until this project WSDOT had not required consultants to calibrate the equipment installed on monitoring or research projects. Prior to this project the equipment manufacturer's certification of accuracy was all that was required. The results of the calibrations done during this study show that there is variability from the manufacturer's specifications and calibrating the equipment is critical for accurate data collection and analysis. Because of this it is recommended that WSDOT develop protocols for monitoring and research to ensure that proper equipment calibration is done.

Designing, installing, and operating a research site is complex and expensive. It is critical that the collected data will stand up to rigorous peer examination. It is also important that the data be accurate because of the potential environmental and financial impacts. In addition to developing the protocols listed above, WSDOT should consider staff training in the calibration, installation, and operation of environmental monitoring equipment. This should be done regardless of whether the monitoring work is done by WSDOT staff or others; because, even if the work is done by others, WSDOT still needs qualified staff to inspect the work and the results to determine if it is being done correctly.

This project provided training for the maintenance staff who worked on the site preparation. This required a high level of supervision by the author and because it was the first project of its

kind it took longer than anticipated to complete the work. The direct involvement of maintenance staff provided an opportunity for them to learn about the function and importance of the environmental BMP's that they maintain.

Monitoring of stormwater BMP's is required under the Municipal NPDES Phase II permit issued to WSDOT by WADOE. It is also a requirement to assess the effectiveness of new BMP's as this project is designed to do. WADOE uses the data derived from the monitoring done by WSDOT and others to determine the effectiveness of stormwater BMP's and set standards; therefore it is imperative that the data forwarded to WADOE be as error free as possible. The attention to detail that is given to the statistical analysis of environmental data should be extended to the equipment that is collecting the data as well.

Bibliography

- Barrett, M., Lantin, A., and Austrheim-Smith, S. (2004). "Storm water pollutant removal in roadside vegetated buffer strips." *Highway Facility Design 2004; Including 2004 Thomas B. Deen Distinguished Lecture*, 129-140.
- Glanville, T. D., Persyn, R. A., Richard, T. L., Laflen, J. M., and Dixon, P. M. (2004). "Environmental effects of applying composted organics to new highway embankments: Part 2. Water quality." *Transactions of the Asae*, 47(2), 471-478.
- Hoppin, M. (2002). "Guidance for Evaluating Emerging Stormwater Treatment Technologies, Technology Assessment Protocol - Ecology (TAPE)." w. S. D. o. Ecology, ed., Washington State, Olympia.
- Hsieh, C. H., and Davis, A. P. (2005). "Evaluation and optimization of bioretention media for treatment of urban storm water runoff." *Journal of Environmental Engineering-Asce*, 131(11), 1521-1531.
- Mazer, G., Booth, D., and Ewing, K. (2001). "Limitations to vegetation establishment and growth in biofiltration swales." *Ecological Engineering*, 17(4), 429-443.
- O'Brien, E., Lisa Austin, Stan Ciuba. (2005). "2005 Stormwater Management Manual for Western Washington: Volume V -- Runoff Treatment BMPs." W. S. D. o. Ecology, ed., Washington State, Olympia, 2580.
- Pitt, R. L., J. Harrison, R. Henry, C. and Xue, D. (1996). "Infiltration through Disturbed Urban Soils and Compost-Amended Soil Effects on Runoff Quality and Quantity."
- Pouyat, R., Groffman, P., Yesilonis, I., and Hernandez, L. (2002). "Soil carbon pools and fluxes in urban ecosystems." *Environmental Pollution*, 116, S107-S118.
- Rushton, B. T. (2001). "Low-impact parking lot design reduces runoff and pollutant loads." *Journal of Water Resources Planning and Management-Asce*, 127(3), 172-179.
- Sun, X. L., and Davis, A. P. (2007). "Heavy metal fates in laboratory bioretention systems." *Chemosphere*, 66(9), 1601-1609.
- Washington_State_Department_of_Transportation. (June). "Highway Runoff Manual." D. o. Transportation, ed., Olympia.
- WSDOT, W. S. D. o. T. (2008). "Highway Runoff Manual." D. o. Transportation, ed., Olympia.
- Yu, S. L., Kuo, J. T., Fassman, E. A., and Pan, H. (2001). "Field test of grassed-swale performance in removing runoff pollution." *Journal of Water Resources Planning and Management-Asce*, 127(3), 168-171.

Appendix A - Rain gauge calibration data

Table 2. Hydrologic Services TB3 rain gauge calibration

Calibration of Hydrologic Services TB3 Rain Gauge -- Serial Number - 00-539

Tube Used sjb-1

Date	Start Time	Nozzle mm/hr	Relative Tips	Cum Vol ml	Depth per tip Mm	Depth per tip Inches	Tips per inch
9/21/2008			5				
9/21/2008	6:24	50	112				
9/21/2008	7:00	50	218				
9/21/2008	7:29	50	326				
9/21/2008	9:29	50	431				
9/21/2008	10:11	50	539				
Tips			534	3272	0.195	0.0077	130.2
			0				
9/21/2008	13:00	100	105				
9/21/2008	13:14	100	211				
9/21/2008	13:34	100	317				
9/21/2008	13:50	100	423				
9/21/2008	14:17	100	528				
Tips			528	3275	0.197	0.0078	128.6

Notes

200 mm TB3: Collected or delivered rain Volume(ml)*.03183 = rain depth (mm)

Depth = Mariott Volume * 0.03183

Area = 31416 square mm

Depth / Mariott volume (approximately 655 ml) = 20.8 mm

Calibrated Volume SJB - 1 :

655ml

Manufacturer's rating = 0.2 mm/tip

Table 3. ISCO rain gauge #2 calibration

Calibration of ISCO 647 #3 -- Serial Number - 203DO1008

Calibration Tube Used sjb-2

Operator: MM

Date	Start	Nozzle	Cum	Cum	Depth	Depth	Tips
	Time	mm/hr	Tips	Vol ml	per tip	Per tip	per
					mm	inches	inch
			16				
10/12/2008	11:34	5.1	82				
10/12/2008	14:50	5.1	151				
10/12/2008	15:18	5.1	222				
10/13/2008	15:44	5.1	294				
10/16/2008	16:14	5.1	354				
	Tips		338	3279.5	0.297	0.0117	85.6

Notes

203 mm ISCO 647: Collected or delivered rain Volume(ml)*.03059 = rain depth (mm)

Depth = Mariott Volume * 0.03059

Area = 32685 square mm

Depth / Mariott volume (approximately 655 ml) = 20.0 mm

Calibrated Volume SJB - 1 :

656.7ml

The manufacturer's rating for this device is 100 tips per inch, or 0.01 inches per tip. The low number of tips per inch indicates that friction has increased dramatically in this gauge and it is no longer usable in its present state. The rain gauge was pulled from service and replaced with another rain gauge.

Appendix B – Methods, detection limits, and quality objectives for water quality testing

The material presented in Appendix B is taken from the Quality Assurance Project Plan prepared by the author for submittal to WSDOE.

Table 4. Methods and detection limits for water quality testing.

Parameter	Analytical Method	Method Number ^a	Sample Holding Time ^b	Field Preservation	Laboratory Preservation	Reporting Limit/Resolution	Units
Hardness	Titrimetric	SM18 2340C	6 months	Cool, 4°C	Cool, 4°C, HNO ₃ to pH < 2	2.0	mg/L
Total suspended solids	Gravimetric	EPA 160.2	7 days	Cool, 4°C	Cool, 4°C	1.0	mg/L
Total phosphorus	Colorimetric	EPA 365.1	28 days	Cool, 4°C	Cool, 4°C, H ₂ SO ₄ to pH < 2	0.02	mg/L
Soluble reactive phosphorus	Colorimetric	EPA 365.1	filtration: 15 min. analysis: 48 hours	Cool, 4°C	Filter	.001	mg/L
Total Kjeldahl nitrogen	Microbe Kjeldahl	EPA 355.1	28 days	Cool, 4°C	Cool, 4°C, H ₂ SO ₄ to pH < 2	0.2	mg/L
Nitrate+nitrite nitrogen	Colorimetric	EPA 355.3	48 hours	Cool, 4°C	Cool, 4°C, H ₂ SO ₄ to pH < 2	.010	mg/L
Copper, dissolved	ICP-MS	EPA 200.8	filtration: 15 min. analysis: 6 months	Cool, 4°C	Cool, 4°C, HNO ₃ to pH < 2 after filtration ^d	0.1	ug/L

Table 4, Methods and detection limits for water quality testing.

Parameter	Analytical Method	Method Number ^a	Sample Holding Time ^b	Field Preservation	Laboratory Preservation	Reporting Limit/Resolution	Units
Copper, total	ICP-MS	EPA 200.8	6 months	Cool, 4°C	Cool, 4°C, HNO ₃ to pH < 2	0.1	ug/L
Zinc, dissolved	ICP-MS	EPA 200.8	filtration: 15 min. analysis: 6 months	Cool, 4°C	Cool, 4°C, HNO ₃ to pH < 2 after filtration ^d	1.0 5.0	ug/L
Zinc, total			6 months		Cool, 4°C, HNO ₃ to pH < 2		
Diesel Range Organics	Gas Chromatograph	NWTPH -Dx	14 days	Cool, 4°C	Cool, 4°C, 1+1 HCl to a pH < 2	0.25	mg/L
Gasoline Range Organics	Gas Chromatograph	NWTPH -Gx	14 days	Cool, 4°C	Cool, 4°C, 1+1 HCl to a pH < 2	0.25	mg/L
pH	Laser	EPA 150.1	14 days	Cool, 4°C	Cool, 4°C	0.1	pH units

^a SM method numbers are from APHA et al. (1998); EPA method numbers are from U.S. EPA (1983, 1984). The 18th edition of *Standard Methods for the Examination of Water and Wastewater* (APHA et al. 1992) is the current legally adopted version in the *Code of Federal Regulations*.

^b Holding time specified in U.S. EPA guidance (U.S. EPA 1983, 1984 or referenced in APHWA et al. (1992) for equivalent method.

^c Depending on the laboratory is used, GFAA or ICP-MS will be used for copper analysis, and ICP-AES or ICP-MS will be used for zinc analysis; each method has equivalent reporting limits.

^d A 0.45 micron fiber nylon filter will be used for dissolved metals (copper and zinc) filtration.

C = Celsius.

GFAA = graphite furnace atomic absorption.

ICP-AES = inductively coupled plasma/atomic emission spectrometry.

ICP-MS = inductively coupled plasma/mass spectrometry.

mg/L = milligrams per liter.

NA = not applicable.

Table 5. Method and quality objectives for water quality data.

Parameter	Laboratory Reagent Blank ^a	Field Reagent Blank ^a	Quality Control Standard Recovery	Laboratory Fortified Sample Matrix Recovery	Laboratory Duplicate RSD ^b	Field Duplicate RSD ^b
Total phosphorus	<20% of minimum sample concentration	<20% of minimum sample concentration	90–110%	75–125%	≤20% or ±2 × RL	≤20% or ±2 × RL
Soluble reactive phosphorus	<20% of minimum sample concentration	<20% of minimum sample concentration	90–110%	75–125%	≤20% or ±2 × RL	≤20% or ±2 × RL
Total Kjeldahl nitrogen	<20% of minimum sample concentration	<20% of minimum sample concentration	90–110%	75–125%	≤20% or ±2 × RL	≤20% or ±2 × RL
Nitrate+ nitrite nitrogen	<20% of minimum sample concentration	<20% of minimum sample concentration	90–110%	75–125%	≤20% or ±2 × RL	≤20% or ±2 × RL
Hardness	<20% of minimum sample concentration	<20% of minimum sample concentration	90–110%	75–125%	≤20% or ±2 × RL	≤20% or ±2 × RL
Copper, dissolved	<20% of minimum sample concentration	<20% of minimum sample concentration	90–110%	75–125%	≤20% or ±2 × RL	≤20% or ±2 × RL
Copper, total	<20% of minimum sample concentration	<20% of minimum sample concentration	90–110%	75–125%	≤20% or ±2 × RL	≤20% or ±2 × RL
Zinc, dissolved	<20% of minimum sample concentration	<20% of minimum sample concentration	90–110%	75–125%	≤20% or ±2 × RL	≤20% or ±2 × RL
Zinc, total	<20% of minimum sample concentration	<20% of minimum sample concentration	90–110%	75–125%	≤20% or ±2 × RL	≤20% or ±2 × RL

Table 5. Method and quality objectives for water quality data.

Parameter	Laboratory Reagent Blank ^a	Field Reagent Blank ^a	Quality Control Standard Recovery	Laboratory Fortified Sample Matrix Recovery	Laboratory Duplicate RSD ^b	Field Duplicate RSD ^b
Diesel Range Organics	<20% of minimum sample concentration	<20% of minimum sample concentration	90–110%	75–125%	≤20% or ±2 × RL	≤20% or ±2 × RL
Gasoline Range Organics	<20% of minimum sample concentration	<20% of minimum sample concentration	90–110%	75–125%	≤20% or ±2 × RL	≤20% or ±2 × RL
pH	<20% of minimum sample concentration	<20% of minimum sample concentration	90–110%	75–125%	≤20% or ±2 × RL	≤20% or ±2 × RL

^a If criteria is not met, associated minimum sample concentration is defined as the new reporting limit (i.e., flagged with U).

^b The relative percent difference will be less than or equal to the indicated percentage for values that are greater than 5 times the reporting limit, and ±2 times the reporting limit for values that are less than or equal to 5 times the reporting limit.

mg/L = milligrams per liter.

NA = not applicable.

RL = reporting limit.

RPD = relative percent difference.

Quality Assurance, Quality Control

The goal of the project is to ensure that data collected are scientifically accurate, legally defensible, and meet the requirements of the WADOE “TAPE” protocol. To meet this goal, the data will be evaluated in terms of five quality assurance objectives:

Precision: A measure of the variability in the results of replicate measurements due to random error.

Bias: The systematic or persistent distortion of a measurement process, which causes errors in one direction (i.e., the expected measurement is different from the true value).

Representativeness: The degree to which the data accurately describe the conditions being evaluated based on the selected sampling locations, sampling frequency, and sampling methods.

Completeness: The amount of data obtained from the measurement system.

Comparability: The ability to compare data from the current project to data from other similar projects, regulatory requirements, and historical data.

Method quality objectives (MQOs) are performance or acceptance criteria that are established for each of the quality assurance objectives. The MQOs identified for this project are described below and summarized in Table 5.

Precision. Precision will be assessed using laboratory and field duplicates. Two levels of precision will be evaluated for laboratory and field duplicates. For values that are greater than 5 times the reporting limit, the relative percent difference (RPD) of laboratory and field duplicates will be as follows: ≤ 25 percent for total suspended solids; ≤ 20 percent for TKN, nitrate + nitrite nitrogen, total phosphorus, metals, and hardness. For values that are less than or equal to 5 times the reporting limit, the RPD of duplicates will be within ± 2 times the reporting limit. In all cases, the RPD of duplicate samples will be calculated using the following equation:

$$RPD = \frac{(C_1 - C_2) \times 100\%}{(C_1 + C_2) / 2}$$

where:

RPD = relative percent difference

C_1 = larger of two values

C_2 = smaller of two values.

Bias. Bias will be assessed by analyzing method blanks, equipment rinsate blanks, matrix spikes, control standards, and laboratory surrogates. The values for method blanks will not exceed the reporting limit, and values for equipment rinsate blanks will not exceed 2 times the reporting limit. The percent recovery of matrix spikes will be between 75 and 125 percent. The percent recovery of control standards will be within 90 and 110 percent for all parameters. Percent recovery for matrix spikes will be calculated using the following equation:

$$\%R = \frac{(S - U) \times 100\%}{C_{sa}}$$

where:

%R = percent recovery

S = measured concentration in spike sample

U = measured concentration in unspiked sample

C_{sa} = actual concentration of spike added.

If the analyte is not detected in the unspiked sample, a value of zero will be used in the equation.

Percent recovery for control standards will be calculated using the following equation:

$$\%R = \frac{M \times 100\%}{T}$$

where:

%R = percent recovery

M = measured value

T = true value.

Representativeness. The sampling design will include samples that represent a wide range of water quality conditions during storm flow conditions. Sample representativeness will be ensured by the use of consistent and standard sampling procedures.

Completeness. Completeness will be calculated by dividing the number of valid values by the total number of values. Valid sample data consists of unflagged data. If less than 95% of the samples submitted to the laboratory are judged to be valid, then additional samples will be collected until at least 95% are judged to be valid. To ensure completeness, the sampling team will use an equipment checklist to prevent a loss of data due to missing containers or inoperable instruments. Automatic recording equipment will also be checked regularly to ensure that it is in good working order.

Comparability. Standard sampling procedures, analytical methods, units of measurement, and reporting limits will be used to meet the goal of data comparability. The results will be tabulated in standard spreadsheets to facilitate analysis and comparison with water quality threshold limits (e.g., WAC 173-201A).

Water quality sampling methods

A minimum of 12 storm events at each monitoring site will be sampled. Up to two of these samples will be collected during the dry season (i.e., May through September) if adequate flow volumes are consistently observed at the associated inlet and outlet monitoring stations.

The following storm event criteria, adapted from the Ecology's Technology Assessment Protocol—Ecology (TAPE) (Ecology 2007), will serve as guidelines for defining the acceptability of storm events for sampling.

Target storm precipitation depth: A minimum of 0.15 inches of precipitation over a 24-hour period.

Antecedent dry conditions: At least 6 hours preceding the event with less than 0.04 inches of precipitation.

Minimum storm duration: At least 1 hour storm duration.

End of storm: A continuous 6-hour period with less than 0.04 inches of precipitation.

The parameters that will be analyzed in each of the samples submitted to the laboratory include total suspended solids, total and soluble reactive phosphorous, Total Kjeldal nitrogen, Nitrate + nitrite nitrogen, hardness, total and dissolved copper, total and dissolved zinc, Diesel and Gas Range Organics, and pH. The primary use of this monitoring data will be to assess the treatment performance of each BMP. Data from inlet monitoring stations located at edge-of-pavement may also be used for characterization untreated highway runoff.

Monitoring equipment consists of Campbell Scientific CR1000 dataloggers, Druck 1830 pressure transducers, ISCO 647 Rain Gauges, and ISCO Automated Samplers. One ISCO sampler will be used to facilitate collection of duplicate samples. To facilitate remote access to the monitoring data, each monitoring station will also be equipped with a Raven cell link. Primary control structures a 3-inch Parshall flume and a 1-inch Parshall flume will be installed to facilitate flow monitoring at the inlet and outlet, respectively, of each bioswale. Piezometers will be installed to allow manual sampling of ground water. Crest gauges will be installed to check the maximum flow of each storm event.

Sampling involves use of the listed equipment for:

- Continuous monitoring of stormwater discharge rates and volumes at the inlet and outlet of the compost-amended and control sections of the bioswale.
- Collection of flow-weighted composite samples at the inlet and outlet of the compost-amended and control sections of the bioswale during discrete storm events for analysis of the following parameters: total suspended solids, total phosphorus, soluble reactive phosphorus, total Kjeldahl nitrogen, nitrate + nitrite nitrogen, hardness, total and dissolved copper, and total and dissolved zinc.
- Collection of grab samples at the inlet and outlet of the compost-amended and control sections of the bioswale during discrete storm events for analysis of northwest total petroleum hydrocarbon-diesel and -gasoline fractions (NWTPH-Dx and -Gx).

- If groundwater is present, collection of grab samples from the piezometers located within the compost-amended and control sections of the bioinfiltration swales during discrete storm events for analysis of the following parameters: total phosphorus, soluble reactive phosphorus, total Kjeldahl nitrogen, nitrate + nitrite nitrogen, hardness, total and dissolved copper, and total and dissolved zinc.

Depth of the maximum flow at three locations in each swale will be determined by crest gauges and checked against flows recorded at the flumes.

Water Quality Sampling Procedures

The automated samplers will be used to collect flow-weighted composite samples from each monitoring station during discrete storm events. The sampler intakes will be carefully positioned to ensure the homogeneity and representativeness of the samples. Specifically, sampler intakes will be installed to ensure an adequate depth for sampling and to avoid capture of litter, debris, and other gross solids that might be present. The sampler suction line will consist of Teflon® tubing with a 3/8-inch inner diameter. Typical programming parameters that will be used in conjunction with each automated sampler are summarized in Table 6.

Potential storm events for sampling will be identified on the basis of long-range weather forecasts that provide information on their associated precipitation depth and duration. Once a storm event has been identified for sampling, field personnel will visit each station to verify that the automated samplers are operational, to place a clean 9.4-liter polyethylene carboy and crushed ice in the automated sampler, and to begin the sampling program. During the sampling, the automated samplers at each station will be programmed to begin sampling when the rain gauge records 0.04 inches of rain within a 2-hour period. The automated samplers will then collect 150-milliliter (mL) sample aliquots at preset flow increments until a maximum of 60 aliquots have been collected. Based on the expected size of the storm, the flow increment will be adjusted to ensure that the following criteria for acceptable composite samples are met at each station:

- A minimum of 10 aliquots will be considered optimal. If 7-9 aliquots are collected, the sample will be considered acceptable if all other sample criteria are met.
- For storm events lasting less than 24 hours, sampling will be targeted to capture at least 75 percent of the storm event hydrograph. For storms lasting longer than 24 hours, sampling will be targeted to capture at least 75 percent of the hydrograph of the first 24 hours of the storm.
- The maximum time period over which samples will be collected is 48 hours.
- The sample pacing required to meet these criteria will be determined by plotting projected rainfall totals on a rainfall-runoff rating curve that will be generated for the monitoring site once sufficient data have been collected. The flow increment programmed into the sampler will be documented in standardized field forms that will be filled out before and after each storm event.

Table 6. Typical programming parameters for automated samplers for composite sample collection.

Parameter	Input Value
Data interval	5 minutes
Number of sample bottles	1
Sample bottle size	9.4 liters
One part program	NA
Once enabled, stay enabled	NA
Pauses and resumes	0
Number of samples at start	NA
Run continuously?	No
Sample at beginning?	No
Sample at enable?	No
Number of samples	60
Sample volume	150 mL (60 samples x 150 mL = 9 liters)
Rinse Cycles	3
Enable	Inlet: rain >0.04 inches/2 hours
Units	Length = feet; volume = cf; flow = cfs

cf = cubic feet.

cfs = cubic feet per second.

mL = milliliters.

NA = not applicable.

Raven link software ® will be used during storm events to monitor equipment from the office. If the software shows that the equipment is not operating properly, a technician will be dispatched to correct the problem. The software will also be used to adjust the timing of the automated sampler grabs during the storm if the storm is evolving differently than forecasted.

After each targeted storm event, field personnel will return to the site, make visual and operational checks of the sampling equipment, and upload the sample collection data from the automated samplers using a laptop computer or proprietary data transfer device. The carboys at each station will then be removed from the automated samplers, capped, and transported to the laboratory on ice (samples will be maintained at a temperature of 4 degrees Celsius (°C) or colder) within the allowable limits for sample holding times. In conjunction with these activities, key information (e.g., number of sample aliquots and estimated volume of composite sample) from each station will be documented on standardized field forms.

The sample collection data will then be reviewed to determine whether the total number of composite samples and the sampling coverage meet the minimum criteria for acceptable composite samples. Hydrologic data will also be examined to determine if the minimum criteria specified in the Experimental Design section for storm precipitation depth, antecedent dry period, and duration were also met. If all the required criteria have been met the laboratory will be instructed to process the associated carboys for subsequent analysis of the required monitoring parameters. If the criteria have not been met, the laboratory will be instructed to discard the sample water in the carboys and clean them in preparation for the next sampling event.

If all the required criteria have been met and the samples are deemed acceptable, laboratory processing will involve transferring the sample water from the carboy to clean, preserved (where appropriate) sample bottles for the required analyses. During this procedure, the carboys will be continually agitated to ensure that each sample bottle receives a representative sample. All collected samples will then be analyzed for total suspended solids, total and soluble reactive phosphorous, Total Kjeldal nitrogen, Nitrate + nitrite nitrogen, hardness, total and dissolved copper, total and dissolved zinc, and pH.

Appendix C – Seed and fertilizer specifications

Table 7. WSDOT erosion control seed mix

% Pure Seed	Botanical Name	Common Name	% Germination
43.78	Festuca rubra L.ssp. rubra	Creeping red fescue	90
42.54	Lolium perenne L.	Perennial ryegrass	85
4.95	Trifolium repens L.	White clover	94
4.94	Agrostis castellana	Highland colonial bentgrass	85
2.00	N/A	Crop seed	N/A
1.72	N/A	Inert Matter	N/A
0.07	N/A	Weed seed	N/A

No noxious weed seeds are allowed in seed mix and none were reported by producer. Seed lot was tested in June 2008. Seed was sown at a rate of 8 pounds per 1000 square feet

Seed lot # 207WLBDEC-02, obtained from

Wilbur-Ellis Co., 1519 14th Street NW, Auburn, WA 98001

Seed information was copied from label that was sown onto the seed bag. Such labels are required and regulated by the Washington State Department of Agriculture.

Fertilizer used was a slow release 23-11-11 (N-P-K) at a rate of 3 pounds per 1000 square feet on the control bioswale only.

Appendix D – Soil profile information

Table 8. Soil profile properties for SR 518 site. Soil profile was done on 6/12/2008.

Horizon/depth	Structure	Mottles	Roots	Range of horizon	Boundary
A/0-2”	N/A	N/A	2F	1.5-2	as
Bw1/2-4.5”	Sbk, c→m, 2	c1d	2F	2-2.5	as
Bw2/4.5-9”	Sbk, c→m, 2	c1d	1vf	3-4.5	aw
CB/9-16”+	pl, c→f, 2	N/A	v1vf	N/A	N/A

Table 9. Soil description:

A	0-2 inches – Dark brown (moist), structureless; common, fine roots; abrupt, smooth boundary
Bw1	2-4.5 inches – medium brown (moist), moderate, coarse to medium, subangular blocky; common, fine, distinct mottles; common, fine roots; abrupt, smooth boundary
Bw2	4.5-9 inches – light brown (moist), moderate, coarse to medium, subangular blocky; common, fine, distinct mottles; few, very fine roots; abrupt wavy boundary
CB	9-16+ inches – dark gray (moist), moderate, coarse to fine, platy; very few, very fine roots

Notes: Location, median of SR 518, south of asphalt ditch edge, 149 feet east of catch basin located at approximately mile post 1.29. Vegetation present consists of grasses and forbs in the median. *Populus trichocarpa* (cottonwood), *acer macrophyllum* (big leaf maple), and *pseudotsuga menziesii* (Douglas-fir) are present on the roadside outside of the roadway. Expected vegetation for the area is a douglasfir/hemlock association.

Silica accumulations were noted on the bottom of rocks in the CB horizon. No pores were apparent in the soil horizons.

Appendix E – Additional construction photos



Figure 22. Bioswale site before construction began

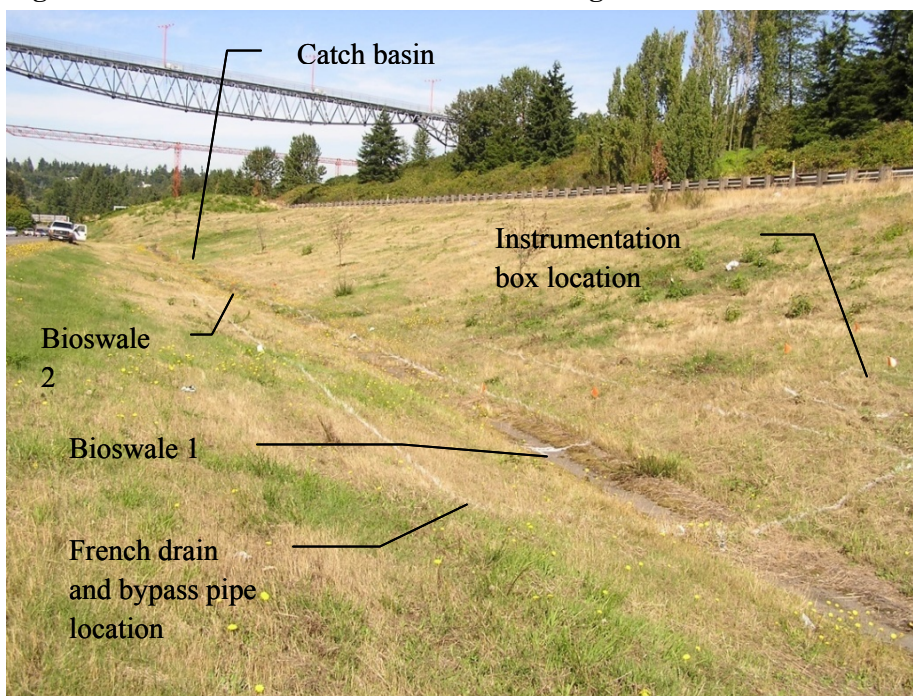

Figure 23. Bioswale preliminary layout



Figure 24. Excavator removing asphalt lining in ditch



Figure 25. Wood box for TB3 pit rain gauge showing drain to French drain (left) and fully installed



Figure 26. WSDOT workers installing pipe and plastic sheeting in French drain



Figure 27. Bioswale 1 with dam at bottom end and French drains

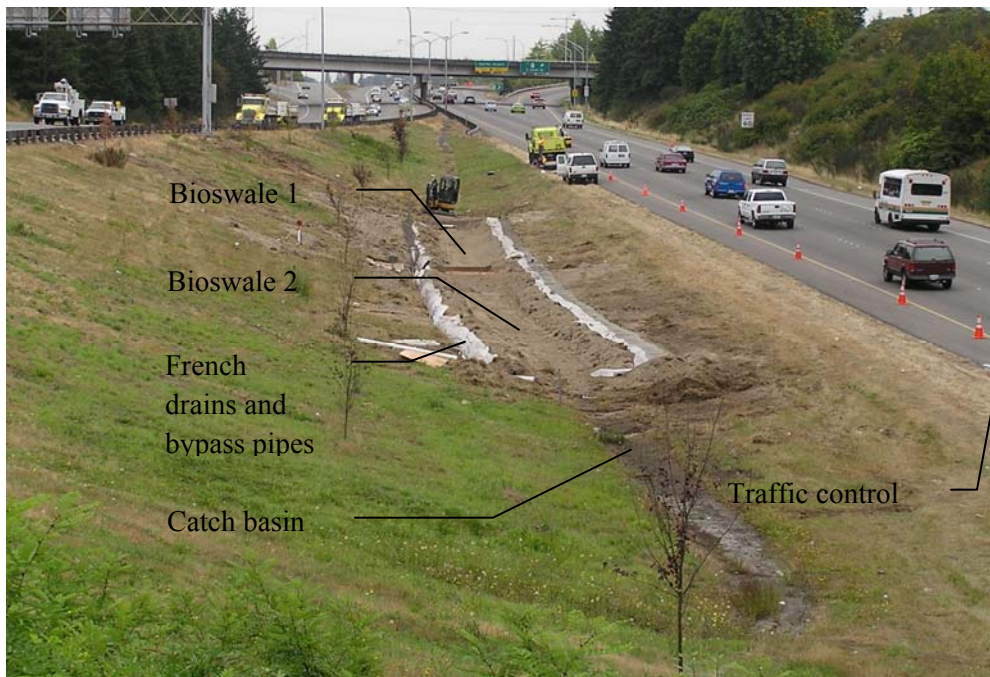

Figure 28. Bioswales ready for compost (bioswale 1) and seeding



Figure 29. Bioswale with compost blanket installed



Figure 30. Hydroseeding Bioswale 1 with trailer mounted nozzle



Figure 31. Hydroseeding Bioswale 2 with hose



Figure 32. Hydroseed mixture cover detail September 15, 2008



Figure 33. Vegetation establishment in Bioswale 1 one month after seeding October 17, 2008



Figure 34. Parshall flume at inlet to bioswale 2



Figure 35. Parshall flume at outlet of bioswale 1

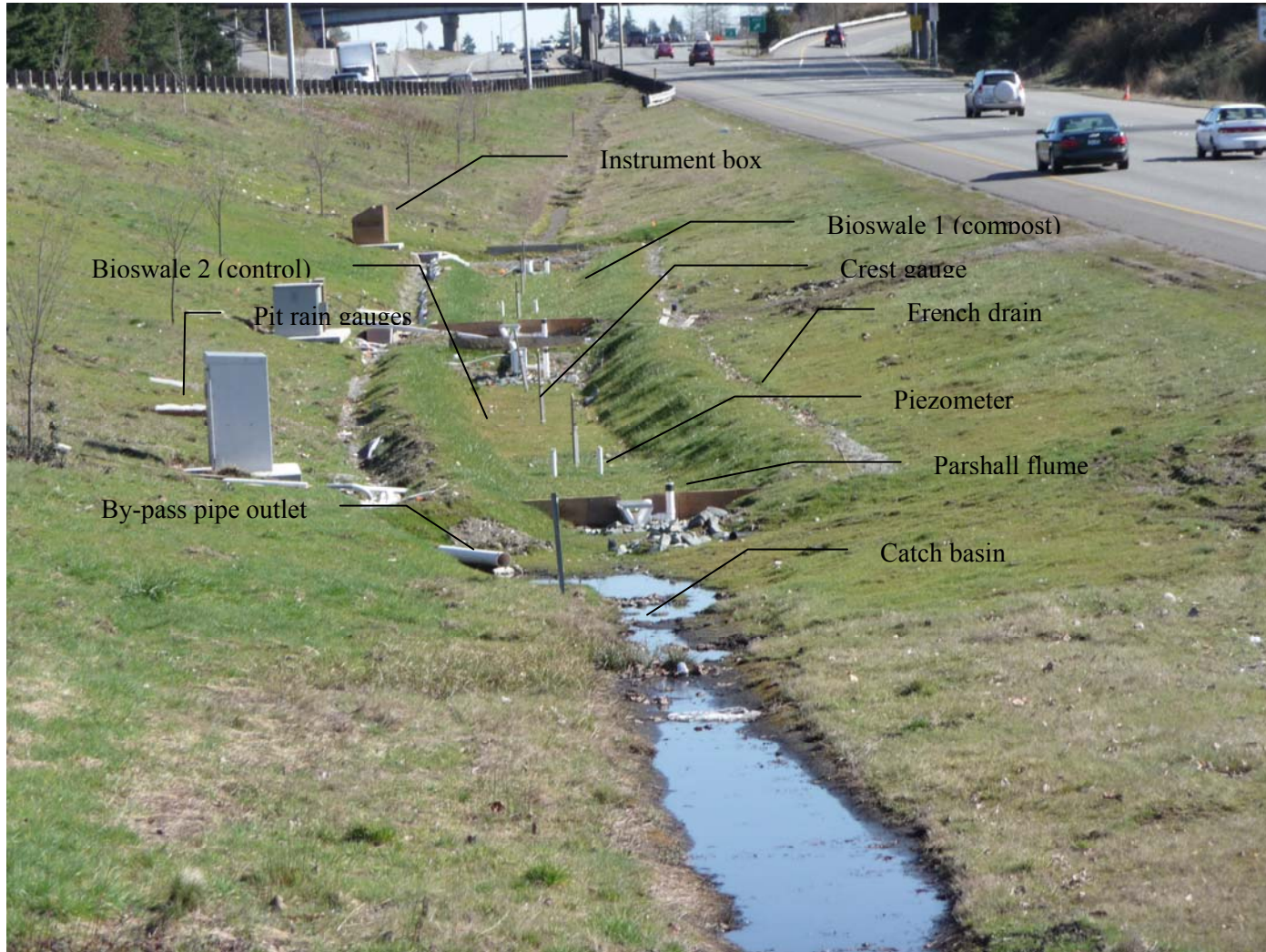

Figure 36. Swales with all equipment in place (March 6, 2009)