

# EE 449 Project Milestone Report II

---

## Automatic Cable Winding For Surgical Robot Arms

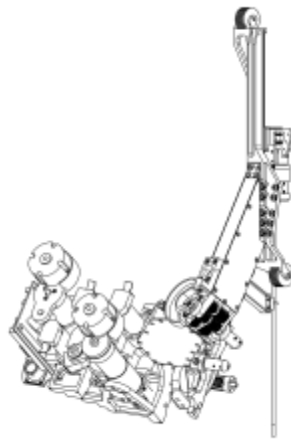

April 23, 2010

Group 5: Imam Tjung and Kiran Thomas

# **Table of Contents**

- 1. Introduction**
- 2. Project Description**
- 3. Performance Criterion**
- 4. Symbols and units**
- 5. System Block Diagram**
- 6. Model Parameters**
- 7. Equations and State Space Model**
- 8. Simulation**
- 9. Simulation Results**
- 10. Controllability and Observability**
- 11. Technical Obstacles**
- 12. Team Management**
- 13. Conclusion**
- 14. Bibliography**

## 1. Introduction

In designing a control system the general flow of tasks are system modeling, simulation, control design, controller performance and robustness testing. This milestone report covers the progress of the Automatic Cable Winding for Surgical Robot Arms project up until the system modeling and simulation. The purpose of this report is to show the progress of the project leading to the second milestone. The objective of the second milestone is to model the system, simulate the model and display relevant data of the simulation. The model of the motor and capstan was calculated successfully using previously established methods. This model was then simulated using MatLab's Simulink and the responses to input signals were in line with similar systems.

## 2. Project Description

The project originated from the problem of winding cable drivers on the Bio Robotics Lab's surgical robot RAVEN [6]. The cable drivers' capstan has to be wound by hand when it is built and also when it is re-cabled after maintenance. The drivers are located at hard to reach places on the arm and that makes the cabling more tedious.

The solution was to create a controller for the motor connected to the driver capstan. The controller should be able to rotate the capstan at a specified velocity for a certain number of turns. Since the cable has to be wound taught, the other end of the cable will be under constant tension from a unwinding bobbin. The bobbin should maintain constant torque. The issue with providing constant torque is discussed in the technical obstacles section. The system should be able to wind the cable in two different directions since the cables system of the robotic arm using cables wound in opposite directions. The user should also be able to specify the velocity and number of turns within a range.

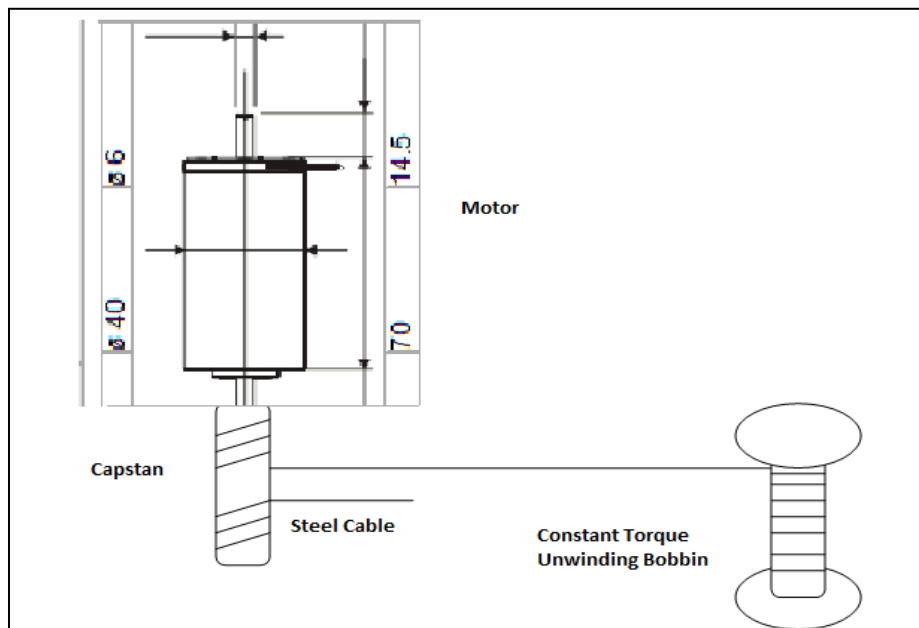

Figure 1 Parts of the System

### 3. Performance Criterion

The performance criterion was determined based on multiple factors:

- The controller should be able to track the specified velocity with 95%+ accuracy.
- The controller should detect and stop the motor in less than 1 sec if the cable gets dislodged from the capstan.
- The system should hold the position of the capstan at a reasonable amount of time (~1-5minute) after the cable is wound.

### 4. Symbols and units

The symbols and their corresponding units used in this report are:

Input voltage  $V_a(t)$  (V)  
Current  $i$ (Amps)  
Load torque  $T_L(t)$  (N-m)  
Torque constant  $K_T$  (N-m/A)  
Speed constant  $K_v$  (V/(rad/sec))  
Back emf voltage  $e(t)$  (volts)  
Viscous friction  $B_m$  (N-m)  
Motor terminal resistance  $R_m$  ( $\Omega$ )  
Motor terminal inductance  $L_a$  (H)  
Motor torque  $T(t)$  (N-m)  
Motor angle  $\theta$  (rad)  
Angular velocity  $\omega$  (rad/sec)  
Amplifier Gain  $K_A$   
Rotor + capstan inertia  $J_m$  (kg-m<sup>2</sup>)

### 5. System Block Diagram (inputs, outputs and state)

The system consists of the following components [5]:

A Linux based PC which sends the controller signal as bits via USB to a I/O board and also receives sensor signals to compute the error.

USB I/O board custom made for the BRL which converts bits to voltage and vice versa

Motor controller, motor and capstan which constitutes the plant. The inputs to the plant are the voltage signal from the I/O board and the load torque from the cable.

Encoder, which is the sensor that communicates the angular position of the motor to the I/O Board.

A graphical representation of the system is shown in Figure 2 below.

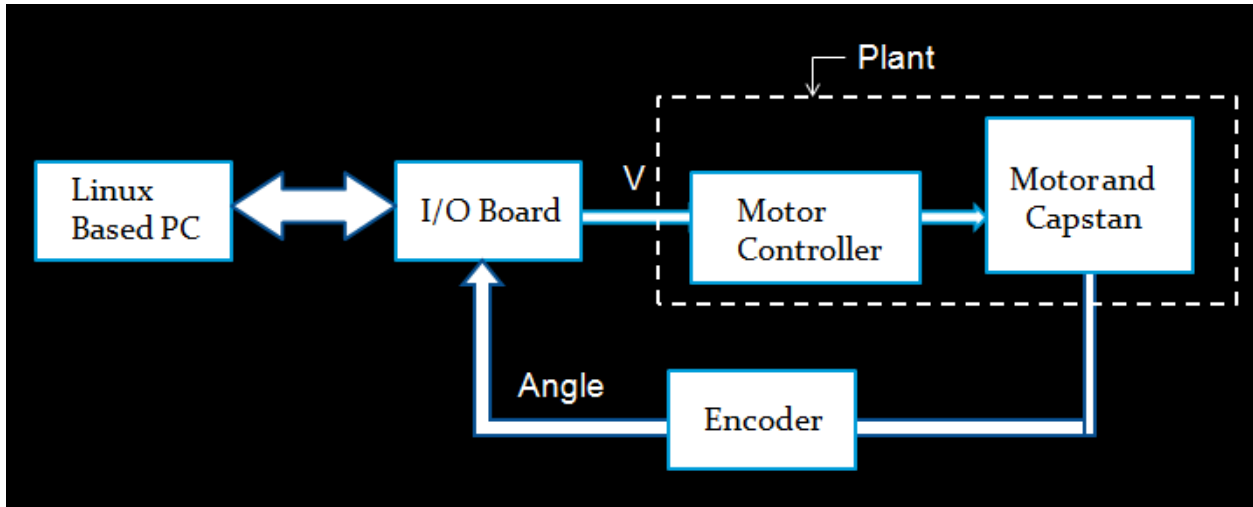

Figure 2. System Block Diagram

## 6. Model Parameters

Electrical Parameters:

Self inductance ( $L_a$ ) = 1280 mH

Terminal Resistance ( $R_m$ ) = 4.94 ohms

Mechanical Parameters:

Torque to Speed Ratio ( $B_m$ ) =  $1.1507 \times 10^{-3}$  Nm/(rad/sec)

Plant inertia ( $J_m$ ) =  $85 \text{ gcm}^2 + 21.932 \text{ gcm}^2$

Torque constant ( $K_t$ ) = 0.09167 Nm/Amp

External cable torque ( $T_L$ ) = 0.04 Nm

The plant inertia consists of the inertia contribute by the motor rotor and the capstan. Since the capstan could not be isolated the total inertia was calculated by using the rotor inertia from the data sheet and calculating the capstan inertia using the equation:

$$I_z = \frac{1}{2} \pi \rho h (r_2^4 - r_1^4)$$

Where, h is the height of the capstan, rho( $\rho$ ) is the density of steel, r2 and r1 are the inner and our radii of the capstan.

External cable torque was determined from the cable tension on the pulley system using a force sensor.

## 7. Equations and State Space Model

The state space model was derived from the physical system by dividing the motor into two subsystems resulting in the equations:

Electrical Equation:

$$V_a(t) = L_a \frac{di}{dt} + R_m i(t) + K_v \omega(t)$$

Mechanical Equation:

$$T_L(t) = K_t i(t) - b_m \omega(t) - J_m d\omega/dt$$

Friction torque inside the motor is modeled by the term  $b_m(\omega)(t)$  which is a non-linear function of  $\omega$ . It would be a simple linear function of  $\omega(t)$  when we consider only the viscous friction model (i.e.,  $b_m(\omega)(t) = b_{\text{viscous}} \omega(t)$  [2]. The non linear damping term was obtained from the motor datasheet.

The figure below shows the state space representation of the model [3]. The matrix  $X$  is the state consisting of the current  $I$ , angle  $\theta$  and angular velocity  $\omega$ . The matrix  $u$  is the input of the system, the voltage  $v$  and the load torque.

$$X = \begin{bmatrix} X1 \\ X2 \\ X3 \end{bmatrix} = \begin{bmatrix} I \\ \Theta \\ \omega \end{bmatrix} \begin{matrix} \text{amps} \\ \text{rad} \\ \text{rad/sec} \end{matrix} \quad u = \begin{bmatrix} u1 \\ u2 \end{bmatrix} = \begin{bmatrix} V \\ Tl \end{bmatrix} \begin{matrix} \text{volts} \\ \text{N-m} \end{matrix}$$

$$\begin{bmatrix} dX1/dt \\ dX2/dt \\ dX3/dt \end{bmatrix} = \begin{bmatrix} -R_m/L_a & 0 & -K/L_a & X1 \\ 0 & 0 & 1 & X2 \\ K/J_m & 0 & 0 & X3 \end{bmatrix} + \begin{bmatrix} 0 \\ 0 \\ -b_m(X3)/J_m \end{bmatrix} + \begin{bmatrix} K_A/L_a & \Theta \\ 0 & 0 \\ 0 & -1/J_m \end{bmatrix} \begin{bmatrix} u1 \\ u2 \end{bmatrix}$$

Figure 3. State Space Representation

## 8. Simulation

Since the model is based solely on data sheet numbers, a simulation was done to assess its response to a constant input. Simulink was used to create a block diagram [2] for the simulation as shown in Figure 4. The plant block consists of the electrical and mechanical systems. The input signal used for the simulation was a 1 volt step and a 0.4 N-m constant torque. The results of the simulation are shown in the next section.

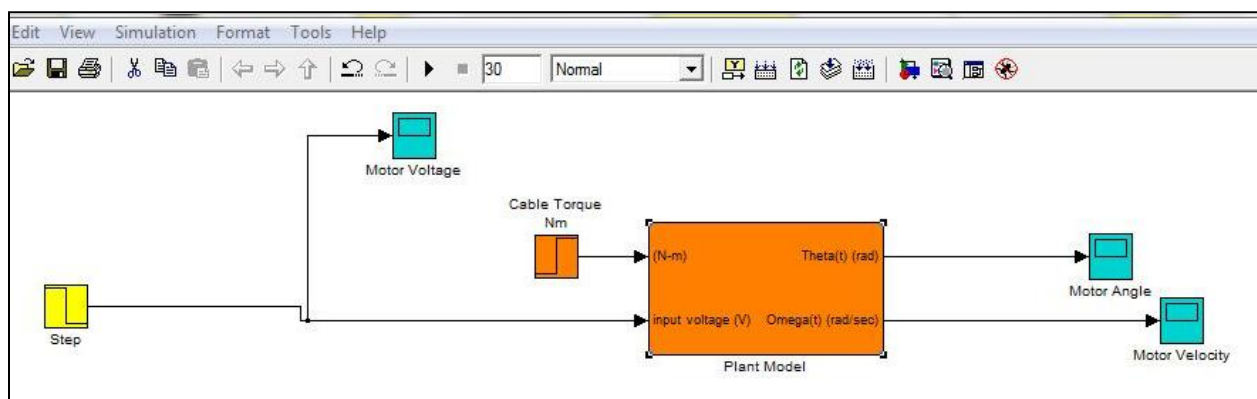
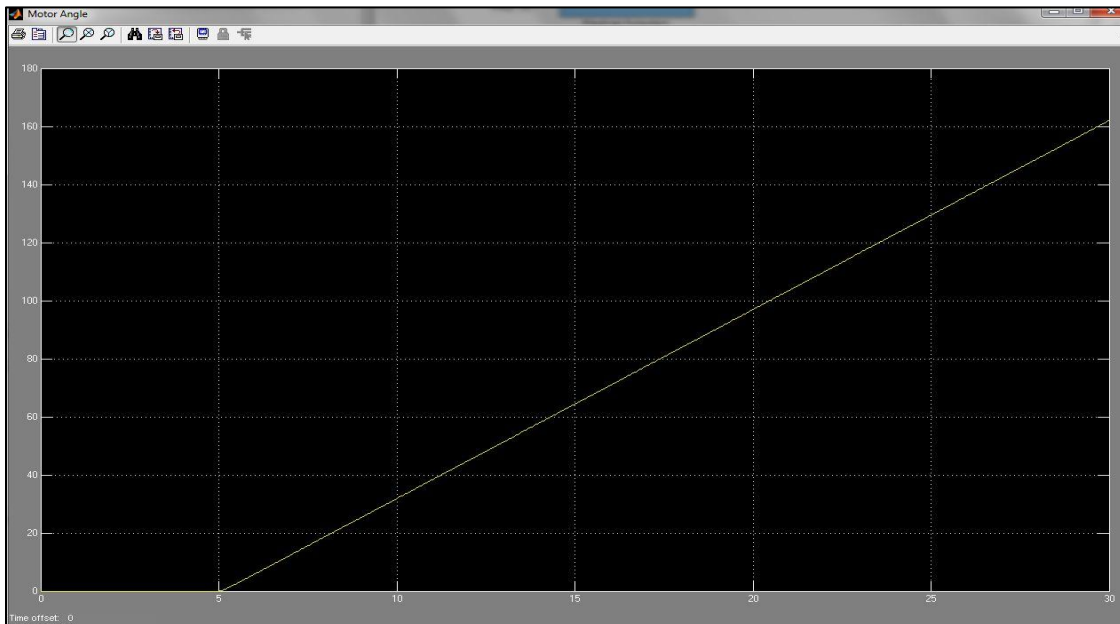

Figure 4. Simulink diagram

## 9. Simulation Results

The outputs of the simulation are the angle of the motor and the motor velocity. The two figures below shows these responses. Both graphs are as expected i.e. the motor angle increases continuously after the step input starts and the motor velocity rises to a constant value quickly and maintains that velocity.



**Figure 5. Motor Angular Position** – The angular position increases at a steady rate once the 1 volt step input begins

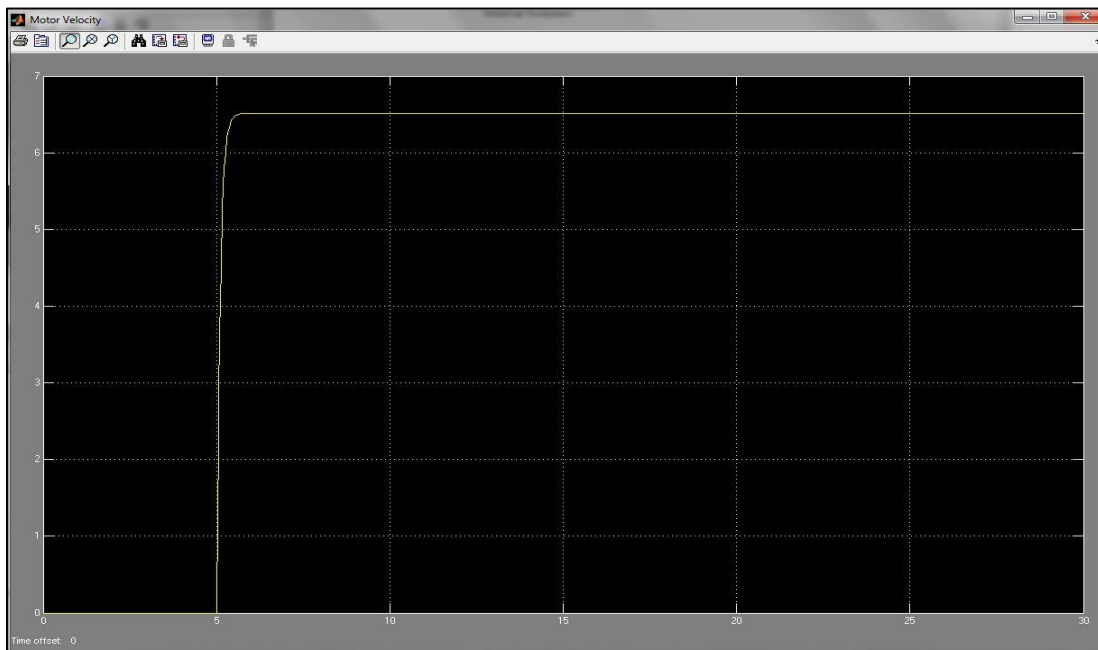

**Figure 6. Graph Showing motor velocity** – the velocity increases quickly to a constant value and then maintains that value

## 10. Controllability and Observability

The controllability and observability of the system was assessed using a method shown in the book "Control Systems Engineering" [1]. The controllability was assessed by obtaining the controllability matrix using the A and B matrix from the state equation. A MatLab command directly calculates the matrix and also the rank. If the rank of the controllability matrix is the same as the order of the plant, then the system is controllable. The figure below shows a MATlab screen shot of the calculation

```
>> Cm = ctrb(A,B)

Cm =

1.0e+009 *

    0.0000         0   -0.0000   -0.0000    0.0000    0.0007
         0         0         0   -0.0001    0.0000    0.0101
         0   -0.0001    0.0000    0.0101   -0.0007   -1.1382

>> rank(Cm)

ans =

     3
```

Figure 7. Controllability Calculation

Similarly the observability can be calculated from the A and C matrices. Matlab was used to calculate the observability matrix also and the rank was 3 which is the same as the order of the plant. Therefore the plant is observable.

```
>> Om=obsv(A,C)

Om =

1.0e+003 *

         0    0.0010         0
         0         0    0.0010
    8.5672         0   -0.1075

>> rank(Om)

ans =

     3
```

Figure 8. Observability Calculation

## **11. Technical Obstacles**

The first technical issue that was encountered was the lack of knowledge of how to model brushless DC motors. After talking to students at the BRL laboratory, the best way to learn more was to look for research papers that modeled BLDCs as part of their experiment. Using the IEEE Xplore database, over 10 papers were found. These papers were used to gain information and to model the system.

Another technical issue was the calculation of the inertia of the assembly. Since the pulley board holding the motor assembly is currently being used by other students, we cannot remove the cables to obtain step response and transient information to calculate the inertia. As a temporary solution till we are able to remove the cables, the capstan dimensions were measured and the moment of inertia was calculated using the formula for moment of inertia for a cylinder.

One unresolved technical obstacle is the hardware that will provide the constant torque to the motor. A simple idea is to use a hanging weight to provide the force but that tool would require its own setup and space which will make the cabling tedious. We are currently looking into a reel that can provide a torque using a spring.

## **12. Team Management**

Since the team only consists of two members, both of us have split our work into specialized areas so that we can focus on them. Imam Tjung is in charge of learning the interface of the controller and implementing the controller into the PC. Kiran Thomas is in charge of the system modeling, simulation and controller design. Once the controller is designed and tested on the pulley board, we are planning to scale to the actual robot.

Each member's work is completed individually and then we meet to combine the work and resolve any discrepancies.

## **13. Conclusion**

The system model was constructed using methods previously derived and from data directly from the manufacturer sheet. The simulation of this model was successful but the actual accuracy of the model will have to be assessed by comparing it to the simulation data. Based on those differences the model may have to be re-evaluated so that it reflects the actual system.

Since the performance of the controller greatly depends on the accuracy of the model, real test data must be collected and compared to the simulation. Since the plant is relatively simple the controller will work with a moderately accurate model but the tracking performance will be poor. The next step in the project is to conduct open loop testing on the motor and continue designing a controller.

## 14. Bibliography

[1] Norman S. Nise, "Control Systems Engineering", Wiley 2008

- The techniques for assessing controllability and observability were obtained from this book

[2] Uy-Loi Ly, "DC Motor Control", 2010, [https://courses.washington.edu/aa448/DCMotorControl\\_LabDescription.pdf](https://courses.washington.edu/aa448/DCMotorControl_LabDescription.pdf)

- Used to determine the simulink simulation.

[3] "dcmotor", 2010. <https://courses.washington.edu/aa448/dcmotor.pdf>

- Used to determine the State Space equation.

[4] "Maxon EC Motor Data Sheet", 2010.  
<http://shop.maxonmotor.com/ishop/article/article/118898.xml>

- Used to get the model parameters

[5] Atef Saleh Othman Al Mashakbeh, "Proportional Integral and Derivative Control of Brushless DC Motor" European Journal of Scientific Research. ISSN 1450-216X Vol.35 No.2 (2009), pp.198-203

-Used the author's method to model the BLDC motor.

[6] J. Rosen, B. Hannaford, 'Doc at a Distance,' IEEE Spectrum, pp. 34-39, October 2006.

- The paper contained detailed information about the RAVEN projects and photographs