

1. Report No.		2. Government Accession No.		3. Recipient's Catalog No.	
4. Title and Subtitle Methods of Avalanche Control on Washington Mountain Highways - Third Annual Report				5. Report Date November 1973	
				6. Performing Organization Code	
7. Author(s) C. B. Brown, R. J. Evans, T. Fox, E. R. LaChapelle, D. M. McClung, L. Smith				8. Performing Organization Report No.	
9. Performing Organization Name and Address Geophysics Program and Department of Civil Engineering University of Washington Seattle, Washington 98195				10. Work Unit No.	
				11. Contract or Grant No. Y - 1301	
12. Sponsoring Agency Name and Address Washington State Highway Commission Department of Highways, Highway Administration Bldg. Olympia, Washington 98504				13. Type of Report and Period Covered INTERIM July 1972 - June 1973	
				14. Sponsoring Agency Code	
15. Supplementary Notes Co-operation with U. S. Department of Transportation, Federal Highway Administration.					
16. Abstract A collection of reports on several different aspects of avalanche formation. The reports are entitled: 1. Some Considerations for Avalanche Defense Design for the Washington Cascades. 2. Incorporation of Glide and Creep Measurements into Snow Slab Mechanics. 3. Avalanches and Synoptic Weather Situations in the Cascades during the Winters of 1971-72 and 1972-73. 4. Indication of Snow Avalanche Periodicity Through Interpretation of Vegetation Patterns in the North Cascades, Washington. 5. A Visit to the Swiss Federal Institute for Snow and Avalanche Research. 6. Decision Methods					
17. Key Words Avalanche, Snow, Decisions, Weather, Vegetation, Creep, Glide, Dendrochronology				18. Distribution Statement	
19. Security Classif. (of this report) Unclassified		20. Security Classif. (of this page) Unclassified		21. No. of Pages 187	22. Price

Methods of Avalanche Control on Washington Mountain Highways

THIRD ANNUAL REPORT

November 1973

Prepared for Washington State Highway Commission, Department of Highways,
and in cooperation with U. S. Department of Transportation, Federal Highway
Administration, by Geophysics Program and Department of Civil Engineering,
University of Washington.

TABLE OF CONTENTS

	Page
INTRODUCTION.....	ii
SOME CONSIDERATIONS FOR AVALANCHE DEFENSE DESIGN FOR THE WASHINGTON CASCADES by David McClung.....	1
INCORPORATION OF GLIDE AND CREEP MEASUREMENTS INTO SNOW SLAB MECHANICS by C. B. Brown, R. J. Evans and D. McClung.....	23
AVALANCHES AND SYNOPTIC WEATHER SITUATIONS IN THE CASCADES DURING THE WINTERS OF 1971-72 and 1972-73 by Terence Fox.....	30
INDICATION OF SNOW AVALANCHE PERIODICITY THROUGH INTERPRETATION OF VEGETATION PATTERNS IN THE NORTH CASCADES, WASHINGTON by Laura Smith.....	55
REPORT ON A VISIT TO THE SWISS FEDERAL INSTITUTE FOR SNOW AND AVALANCHE RESEARCH, WEISSFLUHJOCH, DAVOS, BETWEEN MARCH 19th AND MARCH 27th, 1973 by R. J. Evans.....	103
DECISION METHODS by C. B. Brown and E. R. LaChapelle.....	107

INTRODUCTION

This annual report for the third year of Research Project Y-1301 collects under a single cover the reports from several different aspects of avalanche formation in the Cascade Mountains. As in the previous annual report, these papers are individual and unrelated summaries dealing with the separate aspects of study under this contract.

Each of the papers included here presents the general conclusions from more than one year of research and hence constitutes a final report on each aspect of research.

The initial paper by David McClung summarizes the essential engineering conclusions from a Ph.D. thesis on creep and glide of the snow cover. It presents the results in a form which can readily be applied to the design of avalanche defense structures in the Cascade Mountains.

The paper by Brown, Evans and McClung introduces McClung's field data into a theoretical treatment of slab avalanche formation.

Terry Fox's paper on winter weather conditions in relation to avalanching in the Cascades summarizes the results of two years of data collection and analysis leading to a M.S. degree in meteorology. It establishes a firm quantitative basis for the well-known effects of warm winter storms on snow stability.

The study of vegetation patterns on avalanche paths in the North Cascades by Laura Smith reports field work conducted for three months in the summer of 1972. It is one of the first such studies to be made in this country. It provides useful baseline data for extension of such studies in the future and

illustrates the relation of avalanche return intervals to vegetation patterns in the Cascades.

The report contains a short summary of a trip to inspect avalanche research and defense systems in Switzerland made by Professor Evans in the winter of 1972/73.

The final report summarizes the findings and recommendations for management of avalanche hazard on the North Cascade Highway. This report, with the five appendices, is the result of a study by Professors Brown and LaChapelle.

SOME CONSIDERATIONS FOR AVALANCHE DEFENSE DESIGN

FOR THE WASHINGTON CASCADES

By David McClung

INTRODUCTION

The Cascade Range is characterized by extremely variable snow conditions. On the lower western slopes a maritime condition prevails with generally wetter, warmer, more dense snow than on eastern slopes. For example, the area near Washington Pass is characterized by a more continental type of snowpack with comparatively cold temperatures and comparatively moderate snow depths. Western areas like Stevens Pass or Mt. Baker would be characterized by a relatively warmer, more dense snow cover.

The field work for this project was done at Stevens Pass and at Cascade Field Station near Mt. Baker ski area. The field estimates of the parameters in this report are best applicable to the lower, western areas of the Cascades, i.e., where the snow cover is relatively warm and dense.

An important consideration in the Cascades is the possible effect of rainfall upon the mechanical properties of snow. Rainfall can occur during any month of the year on the lower, western slopes of the Cascades. Rainfall immediately brings the snowpack to an isothermal condition and it causes the snow to settle very rapidly. Rainfall is often the cause of large wet slab avalanche release forcing highway closure. It may also cause extensive loose snow avalanche activity depending upon the condition of the upper layers of the snowpack. In addition, rainfall also has an important effect upon the viscous processes in the snowpack. Presence of the liquid phase in the snowpack introduces unneeded complexity and difficulties into experimental studies of the mechanical properties of snow.

In this study, field measurements were made relating to the slow, viscous processes in the snowpack during the 1971-72 and 1972-73 snow seasons. The main application of these measurements is for estimation of parameters relevant to snow characteristics of the Cascade Range as input for calculation of the quasi-static loads exerted upon structures such as snow sheds and avalanche defenses.

In addition, a series of snow strength measurements were conducted during the same seasons near Cascade Field Station at Mt. Baker. These measurements constitute the first reported in-situ measurements of snow strength for ductile failure of newly fallen snow. From these measurements it is possible to calculate avalanche dimensions from the earlier work on this project. An application of this concept to spacing at avalanche defense structures on a slope is discussed.

Creep of Snow in the Cascades

In general snow on a slope moves by creep (internal deformation) and by glide (slip of the entire snow cover over the ground). When these processes are interrupted by a fixed, rigid object, stresses are exerted upon that object. The distance upslope from the object for which the creep and glide processes are interrupted is termed the back pressure zone.

The back pressure zone increases as a function of time due to increasing snow depth and the process of snow densification. As time progresses, snow densifies and becomes less compressible. This has the effect of increasing the back pressure zone. Since snow in the seasonal snowpack is always densifying, creep is never steady state and the back pressure zone is always increasing, although very slowly.

Figure 1 shows typical mid-winter creep data taken near Cascade Field Station, Mt. Baker in February, 1973. The average shear strain-rate was

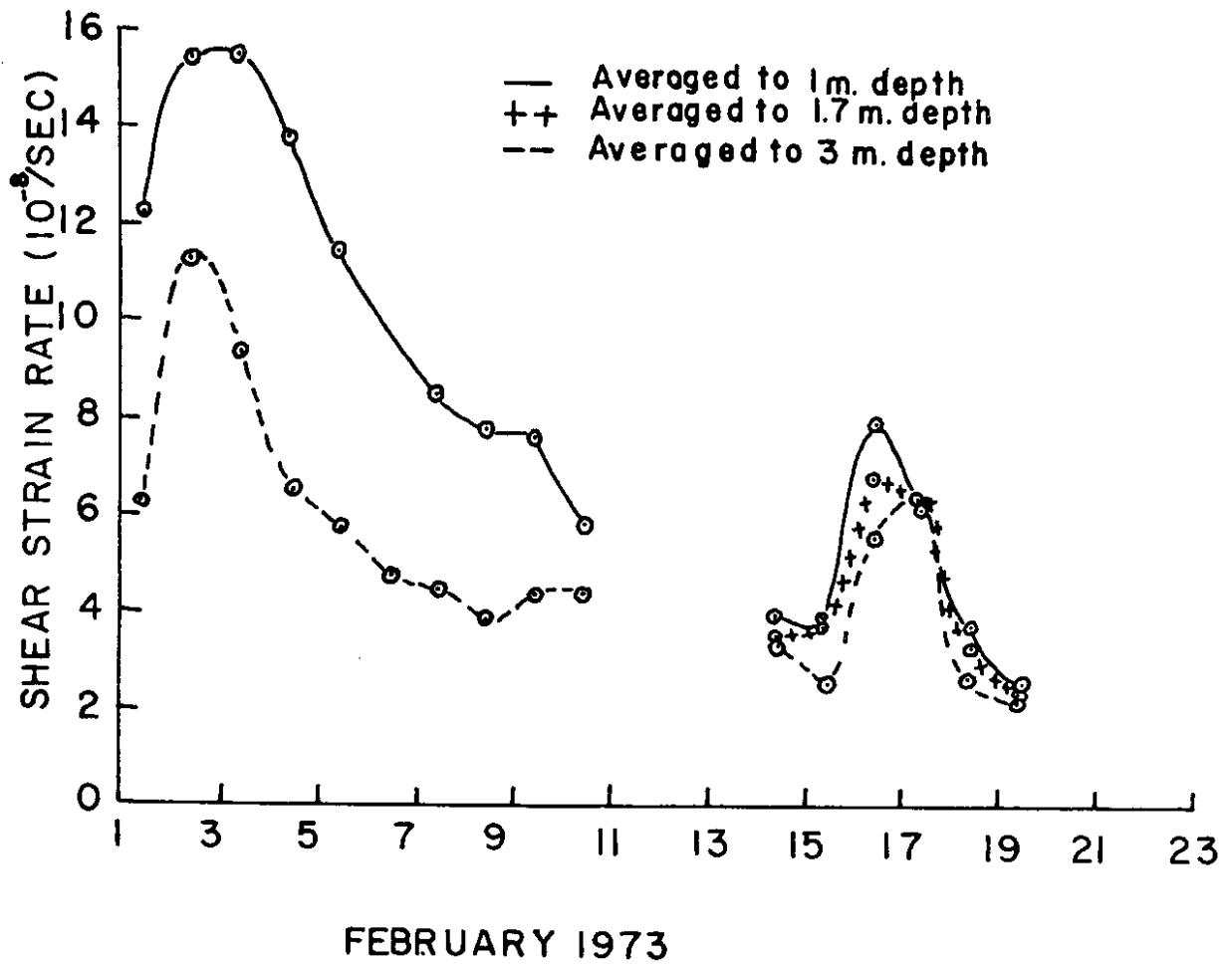

FIGURE 1: Average shear strain rate, south facing slope

determined to various depths in the snow cover by measuring the tilt of one inch diameter poles placed in the snow to various depths. The angle of tilt was measured by means of a sensitive inclinometer.

A number of features should be pointed out from this data:

1) The peaks around February 1-2 and February 16-17 were periods of avalanching in the Mt. Baker area. The peak of February 1-2 follows a period of new snowfall. Slab avalanching was noted in the Mt. Baker area during this period.

The peak of February 16-17 follows a period of rainfall. Extensive loose snow avalanching occurred near Mt. Baker associated with the rainfall.

2) The creep rates are much faster than creep rates measured in springtime.

3) After a period of settling, the creep rates tend to be independent at the depth to which the average rate is taken.

Figure 2 shows typical average shear strain-rates measured in the springtime in the Cascades compared with values measured in Colorado and Switzerland. The method of measurement in each case consisted of removing a vertical core of snow and backfilling with sawdust. After about 60 days, the sawdust columns were excavated.

The strain-rates show somewhat lower values in the Cascades. This is taken to mean that the spring snow densities are generally higher in the measurement area at Mt. Baker than in the more continental climates in Colorado and Switzerland. Measured new snow densities are relatively high in the Mt. Baker area as are snow depths. In addition, the snow cover is usually subject to rainfall which is responsible for rapid densification. Rainfall also causes the snow pack to reach an isothermal condition promoting

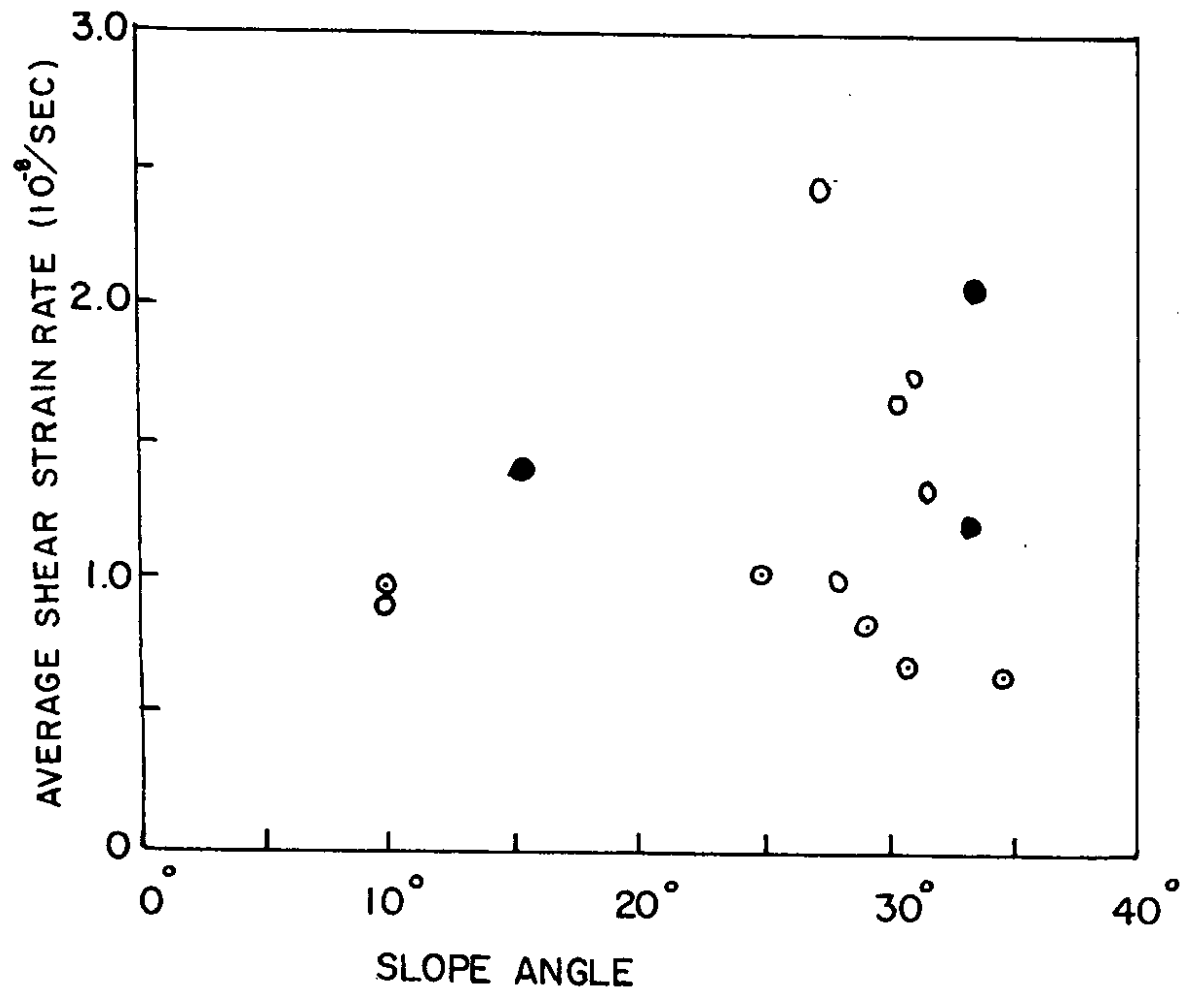

- ROCKY MTS (MARTINELLI)
- SWISS ALPS (HAEFELI)
- ⊙ CASCADES

FIGURE 2: COMPARISON OF CREEP DATA IN WELL-SETTLED SNOW

faster densification than would be the case if the snow cover was cold over most of the season.

Vertical strain-rates were also measured in the spring of 1973 at Mt. Baker by placing markers at various depths above the ground in the core holes before the sawdust was introduced with the position of the markers noted before and after the experiment's vertical strain-rates were calculated.

The estimates at shear and vertical strain-rates enabled the shear viscosity, μ , and bulk viscosity, η , to be estimated as functions of depth in the snowpack. Assuming a two parameter constitutive law, the viscosities are given by:

$$\mu = - \frac{\int \rho g \sin \alpha dy}{\left(\frac{\partial u}{\partial y} \right)} \quad (1)$$

$$\eta = - \frac{\int \rho g \cos \alpha dy}{\left(\frac{\partial v}{\partial y} \right)} - \frac{4}{3} \mu \quad \text{where } \alpha = \text{slope angle} \quad (2)$$

u = velocity parallel to the slope

v = velocity perpendicular to the slope

In general, it was found that μ and η are approximately linear functions at depth from the experiments. Since the snowpack was relatively homogeneous with depth, these experiments indicate that well settled, isothermal snow is a non-linear material.

Figure 3 shows typical estimates at shear and bulk viscosity with depth from experiments in the Spring of 1973 at Mt. Baker.

Snow Gliding Experiments

The other important component in the dynamics of the snow cover is the rate at which the snowpack glides over the ground. Snow gliding is a very complex phenomenon and the mechanism or mechanisms are not well understood.

NORTH FACING SLOPE, NEUTRAL ZONE
31° SLOPE

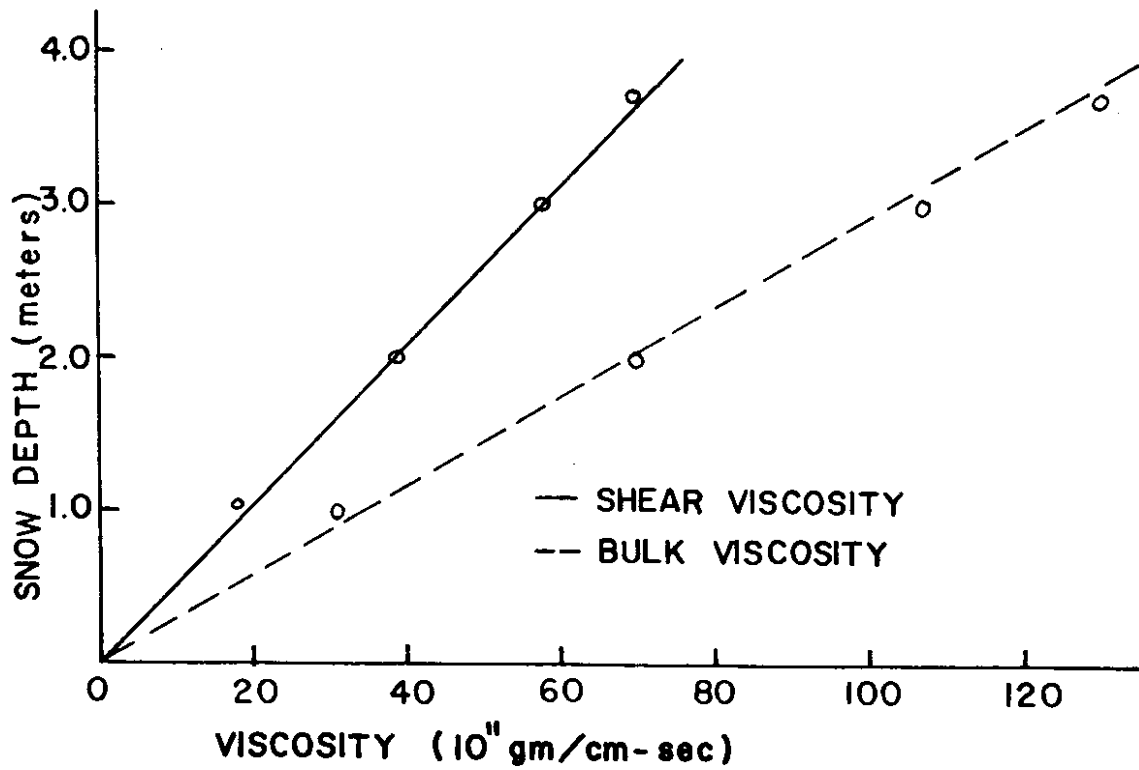

FIGURE 3: VISCOSITY AS A FUNCTION OF DEPTH

Glide has an effect on both the snow pressure and the zone of influence of a structure on a slope. During periods of fast glide, the back pressure zone and the snow pressure increase.

The formulation of a constitutive law relating the glide velocity to the shear stress at the base of the snowpack is necessary in order to include glide as a component to snow pressure.

Glide measurements were made throughout the 1971-72 and 1972-73 snow seasons at sites near Stevens Pass and Mt. Baker. The basic method of measurement involved measuring the position with time of metal glide shoes at the base of the snowpack.

Temperature measurements accompanied glide measurements during the 1972-73 snow season. These measurements were obtained by implanting thermistors a few centimeters below the ground surface. These measurements indicate that the temperature is a fraction of a degree above freezing just below the interface during most of the season. Snow temperature measurements indicate an isothermal (0°C) layer of snow above the interface over most of the season at Mt. Baker.

These temperature measurements suggest that the snow layer at the interface is wet over a majority of the season in the Cascades. This amounts to simplification of the boundary conditions at the base of the snowpack enabling formulation of the relationship between glide velocity and shear stress for the mechanisms of creep and for regelation (pressure melting) for simple interface geometries. Measurements from the Cascades in comparison with this simple theory indicate that creep is the faster and, therefore, the more likely of these mechanisms.

The assumption that creep is the mechanism for glide enables formulation of the necessary glide constitutive law. For a linear creep constitutive

law, the relationship is:

$$\langle \tau \rangle = \frac{\mu u_0}{D} \quad (3)$$

where $\langle \tau \rangle$ is the average basal shear stress, u_0 the glide velocity and D is a quantity termed a stagnation depth. D is independent of $\langle \tau \rangle$, μ and u and is dependent mainly upon the topography at the interface. D may be determined geometrically from creep and glide measurements. Figure 4 shows how D is defined. According to this formalism, D is the fundamental measurement needed to characterize the roughness of the bed. D is expected to increase for smoother slopes and decrease for rougher bed geometries. Table I shows values of D calculated from creep and glide measurements on slopes of constant angle and shows depth from the measurements in the springtime in the Cascades.

The stagnation depth is subject to fluctuations due to changes in conditions at the interface. The most important of these fluctuations is in the form of rain or water at the bottom of the snowpack in the Cascades. Rain has the effect of increasing the rate of glide dramatically over its normal value. This was shown in the data presented in the 1971-72 annual report of this project.

Estimates of Snow Pressure

Knowledge of stresses upon avalanche defense structures due to creep and glide is important to their design. A basic problem consists of calculating snow pressure on structures erected approximately perpendicular to the slope. The structures are assumed to be rigid and edge effects are ignored.

The concept of a back pressure zone is the central idea in the original work on snow pressure by Haefeli (1939). In Haefeli's formulation the pressure on barriers due to creep and glide is proportional to the back pressure zone.

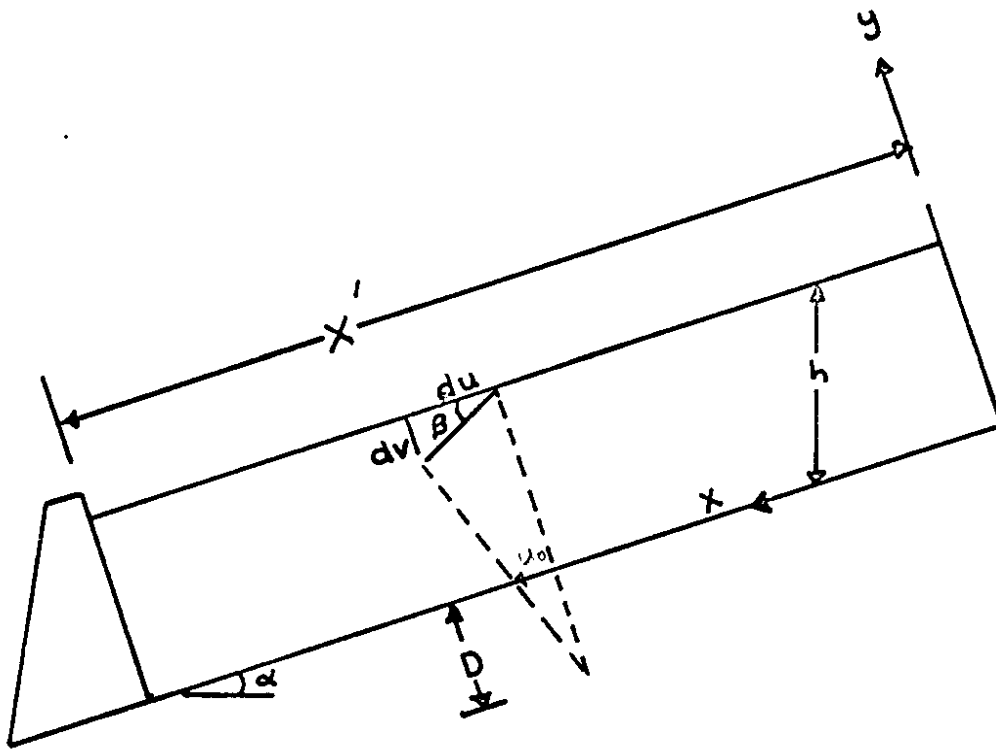

α = SLOPE ANGLE β = CREEP ANGLE

$$\text{TAN } \beta = - \frac{dv}{du}$$

u = creep velocity parallel slope

v = creep velocity perpendicular slope

U_s = GLIDE VELOCITY D = STAGNATION DEPTH

X' = BACKPRESSURE ZONE

h = SNOW DEPTH

SNOW PRESSURE NOMENCLATURE

TABLE I

ESTIMATES OF AVERAGE STAGNATION DEPTHS FROM
CREEP AND GLIDE EXPERIMENTS IN THE CASCADES

STAGNATION DEPTH (CM)	SLOPE ANGLE	TERRAIN DESCRIPTION
28 (1972) 27 (1973)	35°	TIMBERED; SOUTH FACING
24 (1972) 27 (1973)	26°	BRUSHY; SOUTH FACING
20 (1973)	31°	BRUSHY NORTH FACING
33 (1973)	20°	SMALL BRUSH, ROCKS; NORTH FACING
91 (1973)	40°	GRASSY, SMALL BRUSH; NORTH FACING
36 (1972)	26°	BRUSHY; WEST FACING
21 (1972)	31°	TIMBERED; WEST FACING

The assumptions in Haefeli's work include the following:

1. viscosity linear with depth,
2. shear stress proportional to glide velocity with both having a parabolic distribution behind the barrier.

Haefeli's expression for the back pressure zone may be formulated in terms of the stagnation depth, the snow depth measured vertically and a quantity defined as the creep angle (see Figure 4). Table II gives values of creep angles and the related quantity, viscous analog of Poisson's ratio calculated from measurements of shear and vertical strain-rates in springtime in the Cascades.

Perla (1972) showed that although Haefeli defined the creep angle in terms of a geometrical argument, it actually may be rigorously defined by a continuum mechanical argument.

Substitution of the stagnation depth in terms of geometrical parameters defined by Haefeli represents a similar replacement of a geometrical argument by a continuum mechanical argument.

Stagnation depths and creep angles, therefore, are the fundamental creep and glide measurements to be made in order to utilize Haefeli's formalism. Haefeli's expression for the back pressure zone in terms of the fundamental parameters is:

$$x' = h\sqrt{2\cot\beta\cot\alpha\left(1 + \frac{2D}{D+h}\right)} \quad (4)$$

where h is the snow depth measured vertically. Haefeli then gives the creep pressure as:

$$P = \frac{1}{3} x' \rho \sin\alpha \quad (5)$$

where ρ is the average density.

TABLE II:

VISCOUS ANALOG OF POISSON'S RATIO
AND CREEP ANGLES

	AVERAGE		
SLOPE ANGLE	DENSITY (GM/CM ³)	POISSON RATIO	CREEP ANGLE
20°	0.53	0.31	41°
26°	0.50	0.32	22°
30°	0.54	0.23	31°
31°	0.55	0.27	28°

A numerical study of snow pressure on retaining walls was performed in conjunction with this work in order to compare with Haefeli. From the results of the snow creep experiments, it is evident that the shear viscosity is stress dependent. The assumption here is that the shear and bulk viscosities are proportional to the bulk stress. Haefeli assumed a proportionality between viscosity and normal stress. Haefeli's assumption is more difficult to rationalize from the framework of continuum mechanics. From a physical point of view, one expects the viscosity to respond to a longitudinal distribution of stress as well as normal stresses. Accordingly the study performed here assumes a proportionality between viscosity and bulk stress.

Figures 5 and 6 show the results of finite element calculations of snow pressure utilizing the postulated non-linear creep constitutive law and the corresponding non-linear glide constitutive law. Haefeli predicted constant pressure across the barrier. Haefeli's results calculated from equation 5 are shown as dashed lines on the figures.

Comparison of the results show that Haefeli's formulation appears to predict the correct order of magnitude of snow pressure on the structure. However, when back pressure zones are compared, Haefeli's results are in general much too conservative.

The reason that Haefeli's estimates of back pressure zones are too small is that he assumed a parabolic distribution of velocities behind the barrier as opposed to the real distribution which is an asymptotic function.

The results of this comparison show that Haefeli's equations are probably useful when one is interested in a rough estimate of snow pressure. Haefeli's equations tend to underestimate the pressure by about 20% and they do not give the distribution of pressure on the barrier.

Haefeli's equations should not be used to estimate back pressure zones. Back pressure zones may be underestimated by 100% with Haefeli's equations.

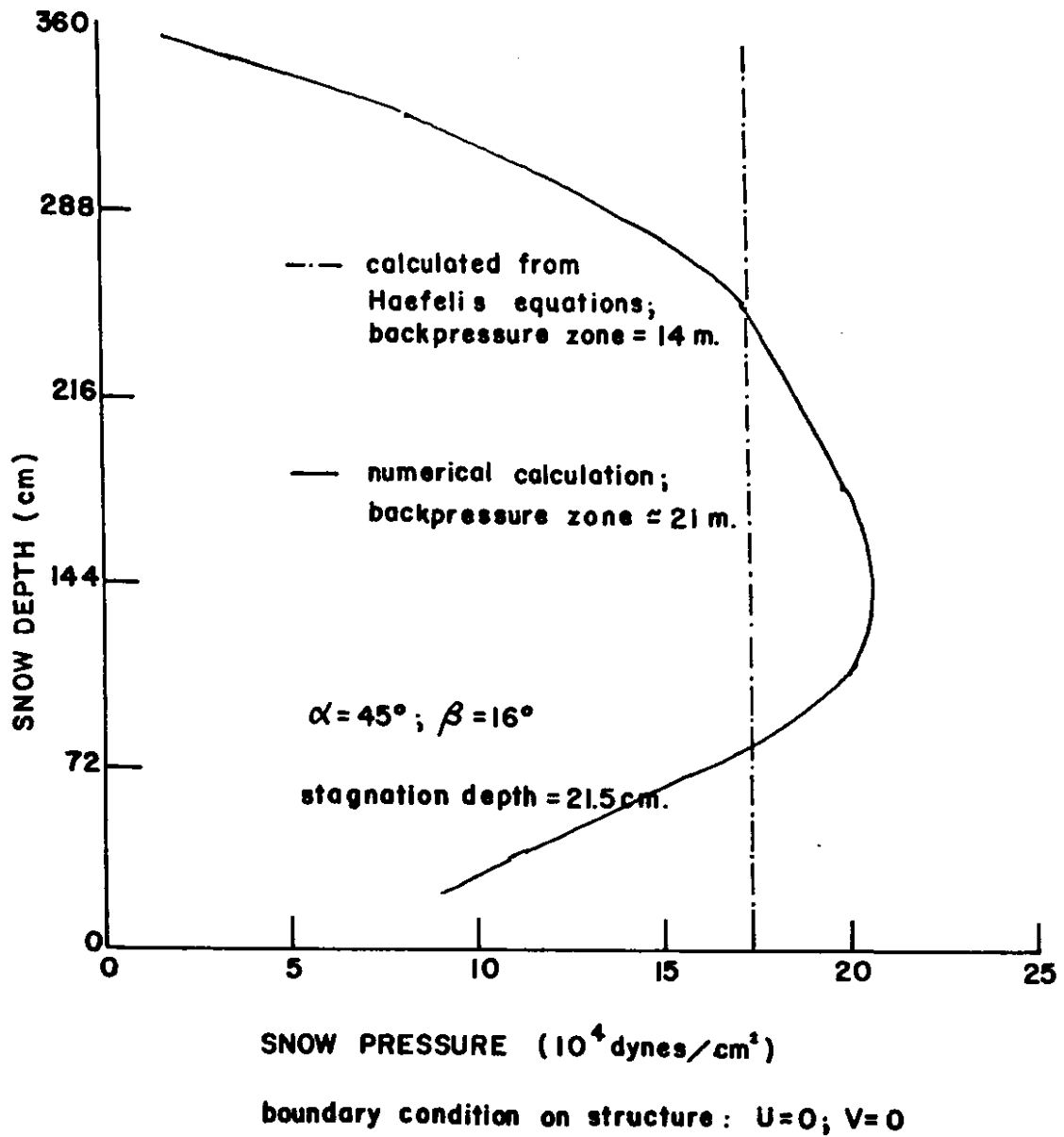

FIGURE 5: SNOW PRESSURE CALCULATIONS

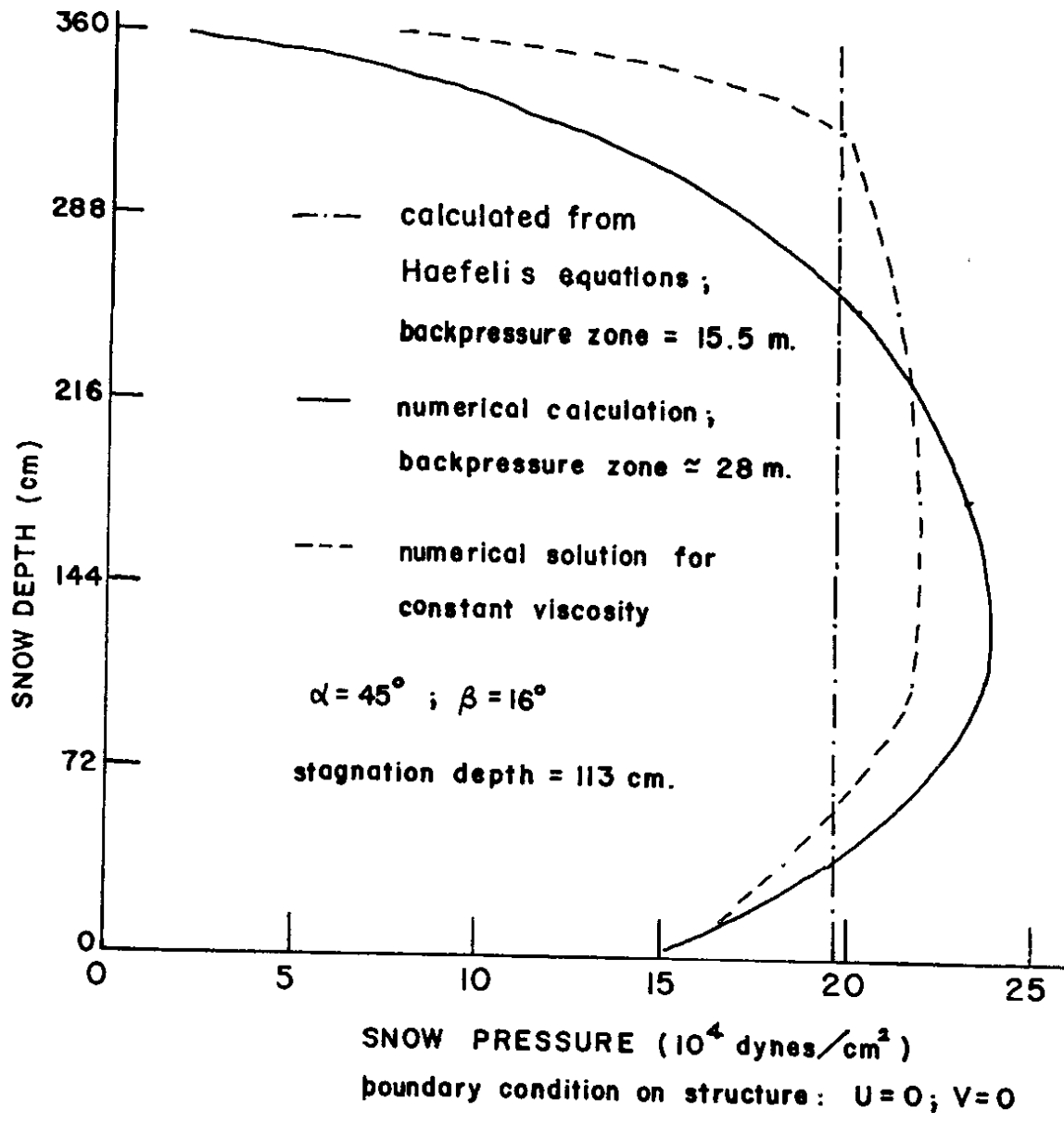

FIGURE 6: SNOW PRESSURE CALCULATIONS

The Swiss Guidelines recommend spacing of avalanche defenses on slopes using Haefeli's estimates of back pressure zones. This is not to be recommended in the Cascades. The discussion in the next section pertains to spacing of defenses on a slope.

Measurements of Snow Strength; Application to Spacing of Avalanche Defenses on a Slope

In-situ measurements of the tensile strength of newly fallen snow were made near Cascade Field Station during 1971-72 and 1972-73. The basic method consisted of tilting large (3 ft. x 6 ft.) tables containing a 1 ft. high sample of snow. The tilting end of the table had a rough fixed surface while the lower end had a specially constructed surface on wheels, also, with a rough surface. Upon tilting the table, the fracture occurred on the interface between the moving surface and the fixed area.

Figure 7 is a plot of the values of tensile strength versus density. These measurements constitute the first reported estimates of ductile failure of newly fallen snow. Perla (1969), reported estimates of tensile strength as a function of density for brittle failure. The scatterband of his data is shown in Figure 7.

The tensile strength of newly fallen snow is important for calculating avalanche dimensions. As indicated in the earlier work in this project, the minimum upslope dimension of slab avalanches is given by:

$$2D = \frac{2\epsilon t}{\rho} \frac{1}{\sin\alpha} + \frac{\nu}{1-\nu} t \cot\alpha$$

where ϵ is the tensile strength, ν is Poisson's ratio and t is the depth of the slab.

It is the goal of avalanche defense work to stabilize the snow cover.

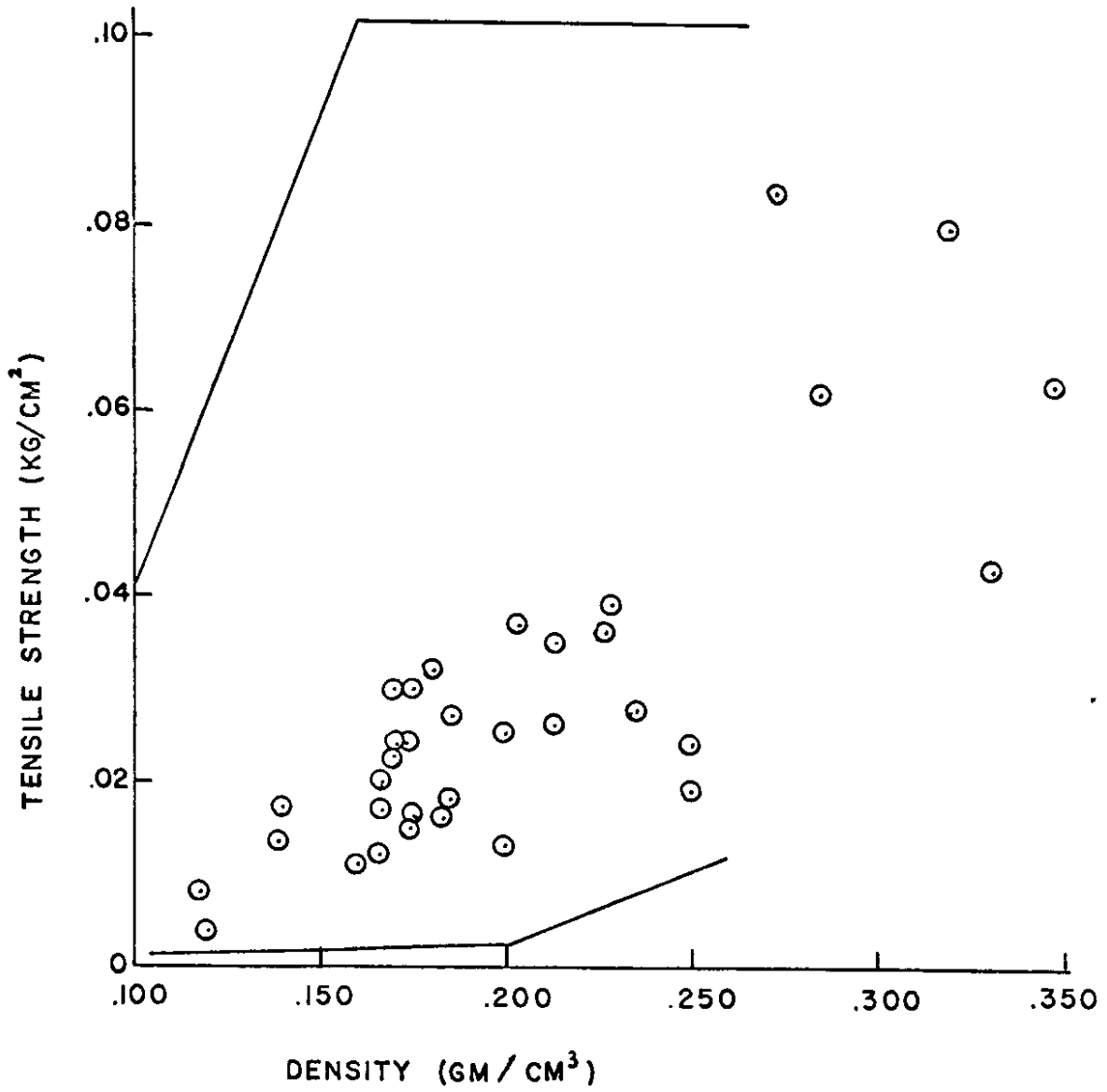

FIGURE 7: TENSILE STRENGTH AS A FUNCTION OF DENSITY

⊙ PRESENT EXPERIMENTS

— SCATTER BAND OF PERLA'S DATA (1969)

In general, the back pressure zone during mid-winter behind a structure will be less than during springtime. The Swiss Guidelines recommend spacing according to springtime estimates of back pressure zones. Therefore, during the winter especially in the top layers of the snow there will be portions of the snow cover which will not feel the influence of a barrier.

It seems reasonable to space structures on a slope corresponding to avalanche dimensions. It may be possible to space structures such that not enough room is left between them to allow large avalanches to form. Figure 8 shows avalanche dimensions plotted as a function of slope angle from the tensile strength measurements in this work and the maximum values given by Perla (1969). The upper curves represent the minimum spacing recommended by the Swiss Guidelines for 3.5 and 7.0 meter snow depths.

Scatter in strength data indicate that avalanche dimensions as calculated from the estimates of Brown, Evans and LaChapelle (1972) may attain values between the estimates from the maximum of Perla's data assuming a very thick slab down to very small values.¹

The question of how to stabilize the snow cover becomes, then, a question of much broader scope than a simple problem in mechanics. Since avalanches may have quite small dimensions depending upon the density, slab thickness and mode of failure, it may be impractical to attempt stopping all avalanches. The problem takes on economic, environmental and practical considerations. One must ask in each given situation what frequency of avalanches may be tolerated in a given location or how large an avalanche can be tolerated in the given location. In addition, it is evident that dynamic loads upon structures will be increasingly important to their design with increasing spacing. Increasing spacing implies larger and more frequent avalanches.

¹ These values are calculated from an open slope condition. The presence of a barrier will introduce compressive stresses into a slab thereby offsetting dangerous tensile stresses and effectively increasing avalanche dimensions.

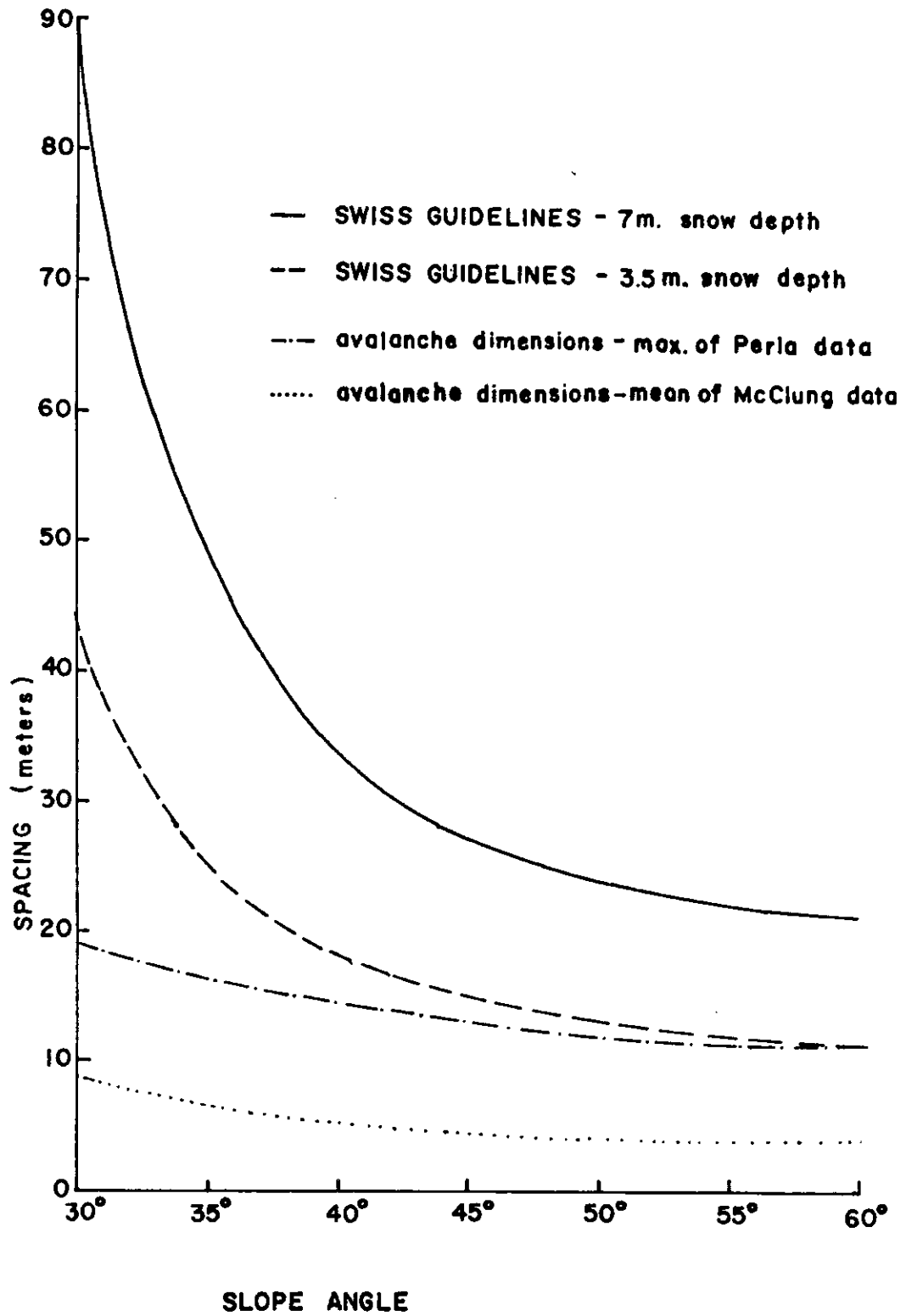

FIGURE 8: SWISS GUIDELINE SPACING verses NEUTRAL ZONE AVALANCHE DIMENSIONS

Conclusions and Discussion

This work attacks the problem of defense against avalanches as two separate questions: 1. What is the quase-static snow pressure that a structure on a slope must be able to withstand? 2. What is the optimum arrangement of structures on a slope to stabilize the snow cover against avalanches?

In relation to the first problem the indications are that the equations of Haefeli are useful in order to provide rough estimates of snow pressure even though the assumptions used in Haefeli's formulism are not completely justifiable. However, in important design problems where the distribution of pressure is required over the structure or where the geometry is complicated, the numerical approach must be used. The numerical solutions require an iteration procedure utilizing the non-linear constitutive laws discussed above.

The numerical method appears to be the only reliable way of estimating the back pressure zone. Haefeli's equations are not at all reliable in this respect.

It is recommended that snow depths, creep angles and stagnation depths be measured in the starting zone of any avalanche path in which defense is considered in order to estimate expected snow pressure. Conditions in the Cascades are extremely variable.

Stabilization of the snow cover against avalanches is a complex problem. Judgement must be made by weighing many factors. It has been pointed out by Frutiger (1965) that existing structures in Switzerland sometimes provide inadequate defense. The discussion in the previous section is intended to provide a rationale for this observed behavior. Ultimately the question must be phrased in terms of the number, size and frequency of avalanches which may be tolerated at the given location from practical, economical and environmental considerations.

REFERENCES

- Bader, H., et al, January 1954. Snow and Its Metamorphism. SIPRE Translation No. 14.
- Brown, C. B., R. J. Evans and E. R. LaChapelle. Slab Avalanching and the State of Stress in Fallen Snow. JGR
- Frutiger, Hans. Behavior of Avalanches in Areas Controlled by Supporting Structures. IASH International Symposium on Scientific Aspects of Snow and Ice Avalanches. 5-10 April, 1965. p. 243.
- Mellor, M. Avalanches. CRREL Cold Regions Science and Engineering Report Part III, Section A3, 1968.
- Nye, J. F. A Calculation of the Sliding of Ice Over a Wavy Surface Using a Newtonian Visions Approximation. Proc. Roy. Soc. A., 311, pp. 445-467, 1969.
- Perla, R., Strength Tests on Newly Fallen Snow. J. Glaciol. Vol. 8, No. 54, October 1969, p. 427.
- Perla, R., Generalization of Haefeli's Creep-Angle Analysis. J. Glaciol., Vol. 11, No. 63, 1972, p. 447.

INCORPORATION OF GLIDE AND CREEP MEASUREMENTS INTO SNOW SLAB MECHANICS

C. B. Brown, R. J. Evans, and D. McClung

ABSTRACT

The conventional field measurements in slab avalanche control include snow strength, creep, and glide. The snow strength appears naturally in any failure criterion, but the inclusion of creep and glide data into the slab mechanics is not obvious. Here, the physical features of creep and glide are discussed. This leads to possible models which can be incorporated into a continuum theory. As a result, definite suggestions are made concerning the range of parameters to be measured in the field.

Introduction

The solution of problems in snow slab mechanics can be based on the formulation of Perla and LaChapelle (1970) where some metamorphosis of either the snow ground interface or some surface in the snow slab causes a reduction in shear capacity. This approach has been further developed by Brown, Evans, and LaChapelle (1972) to find the state of stress in fallen snow and the dimensions of slab avalanches; this work provides no causality for the shear degeneration, and the boundary condition on the interface is described as zero normal motions and a definite shear stress. The solution used is linear elasticity theory.

The first shortcomings of the Brown, Evans, and LaChapelle work are: (1) The inability to model actual interface boundary conditions associated with definite metamorphosis; and (2) the inability to account for the nonlinear and temporal response of the snow. These two features are often included in the expressions, glide and creep. The object of this paper is to discuss the inclusion of these features into snow slab mechanics.

Glide

The relative motion between the ground surface and the juxtaposed snow will serve as a definition of glide. The motion is the measured translations over definite periods of time. It is natural to think of the onset of and subsequent motion being controlled by the laws of Amontons. These would mean that glide would not occur when

$$\tau < \sigma \mu_s \quad [1]$$

where τ is the interface shear, σ the interface normal pressure, and μ_s the static coefficient of friction. When [1] becomes an equality, glide commences and the resistance to this motion is a shear

$$\tau = \sigma \mu_k \quad [2]$$

where μ_k is kinetic coefficient of friction and $\mu_k < \mu_s$. One consequence of such laws is the monotonic increase of the glide speed with time. Examination of the results of Gand and Zupancic (1965) for glide near Davos indicates that the speed increases with time until a terminal value is attained. This speed is then maintained for the rest of the season. The results in figure 1 have a reverse trend inasmuch as the terminal speed is the decay from the high values of the earlier season. Clearly these two sets of readings from Davos and the Cascades are in conflict. However, they do refute the restraint equation [2]; the speed does stabilize in both cases, and the resistance must depend on the speed. Thus

$$\tau = f(v) \quad [3]$$

where v is the glide speed. The functional form of [3] will apparently be completely different in the two cases discussed.

The small scale features at the interface consist of soft snow laid on a hard ground with the possibility of organic separation. The ground is rugged and, because of the differences between hardness of the ground and snow, it is unlikely that the usual concept of slipping can apply. Rowe (1964) has shown, for materials with very different hardness, failure is by shear in the softer material at a layer beyond the envelope of the rough surface. This means that failure

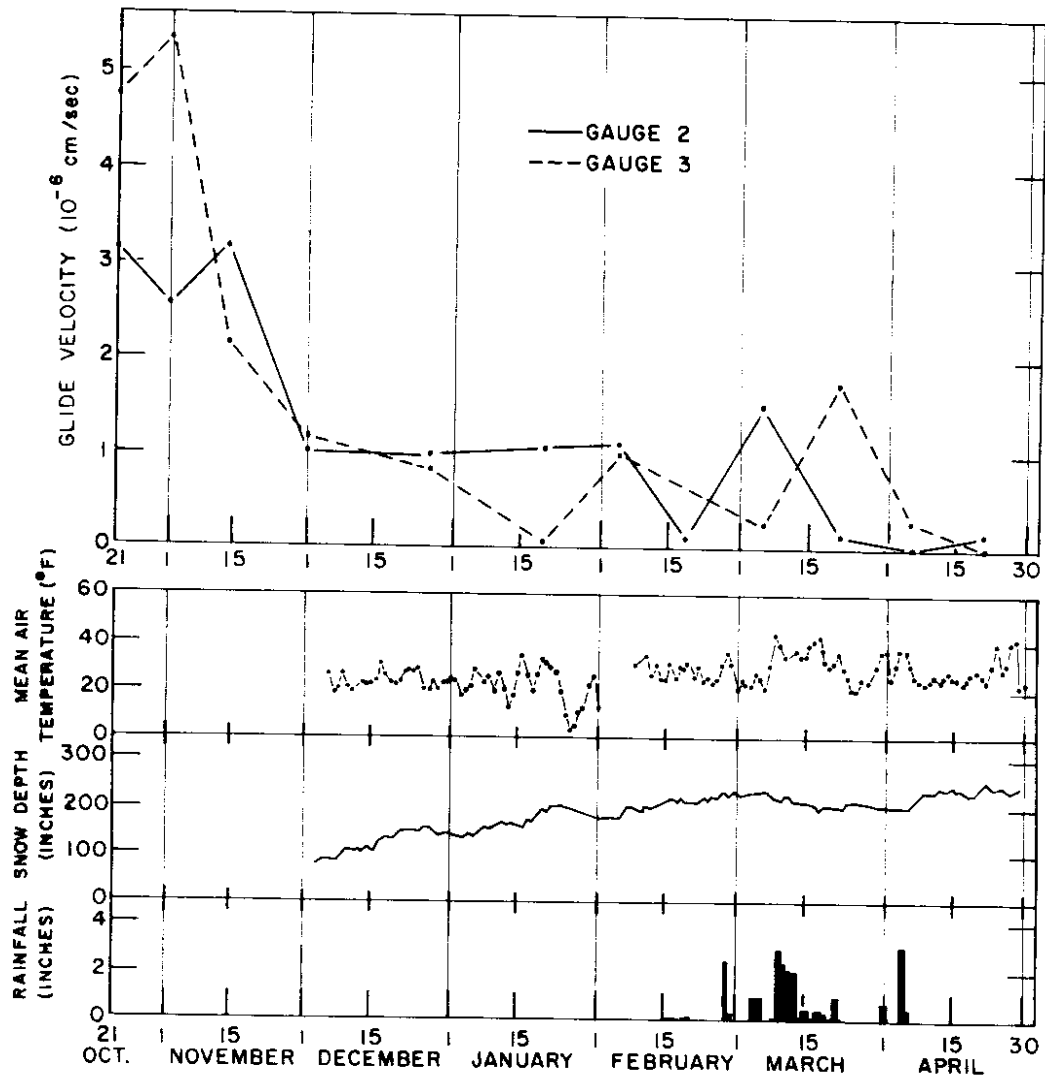

Figure 1. Glide measurements, 1971-72, Mt. Baker, Washington.

would be in the snow itself unless the organic layer was smooth and slippery or unless melt water appeared at the interface. Following up on Rowe's work, we would anticipate that the initiation of glide would be associated with the shear capacity of the snow. Here we would consider a sintered material with the conditions ripe for the application of the Bowden-Tabor (1958) theory of failure across the cohered interfaces of the grains. Unfortunately, in snow the phase state is dependent on the stress conditions as well as the temperature. The usual process of bond fracture at the interface occurs. This can be due to a combination of change of properties as well as the stress level. Healing may also happen. Thus, on the interface in the snow material a continuous process of healing and fracture, associated with regelation, must be expected.

The previous discussion suggests that once steady thermal and mechanical conditions exist near the interface, uniform glide speed should be attained. Until that steady state, the glide speed will depend on the presence of water, the organic layer, the snow condition, the slope and ground smoothness. Whether the glide accelerates to the terminal speed, as in the Davos work, or decelerates as in the work shown in figure 1, depends on these local conditions. The final steady speed will also be affected by the local conditions.

A conclusion concerning glide is therefore that a terminal steady speed will be attained once steady mechanical and thermal conditions exist. The prior speed will be closely associated with local characteristics.

A point with regard to the interpretation of field measurements of glide is worth noting. The glide velocity measured at a particular location depends not only on the interface conditions at that point but also on conditions at other locations on the moving interface, on the snow properties, and on the boundary conditions over the whole slope. Thus, meaningful comparison of results obtained at different sites and different geographic locations is particularly difficult.

Creep

This term is usually applied to deviatoric as well as dilational changes with time. The first is associated with the grains riding over each other, the second with grain readjustment toward a minimum bulk volume. Both processes are aided by the crystals tending to a spherical shape by loss of crystal branches due to vapor diffusion through the air spaces. The grain size decreases and the regime changes allowing local relocation and sliding to proceed rapidly. In spring time the process is aided by the intrusion of melt water from the surface. On a typical slope the creep occurs as motion parallel to and normal to the surface. Shear creep is manifested when the parallel velocity depends on the position of the snow. Dilational creep appears as settlement and uniform bulk motion down the slope. The strain rates in the two modes are of the same order of magnitude on avalanche slopes.

Figure 2 shows results of sawdust column tests in the Cascades. It is noted that the columns remain straight and that the shear creep strain rate is independent of position. This means that the shear strain is constant over the depth whereas the shear stress increases with depth; the constitutive law for the creep process of the snow is not that of a linear, homogeneous, isotropic material.

The creep speeds are of the same order as the measured glide speeds. Both features are therefore equally important in any analytical formulation.

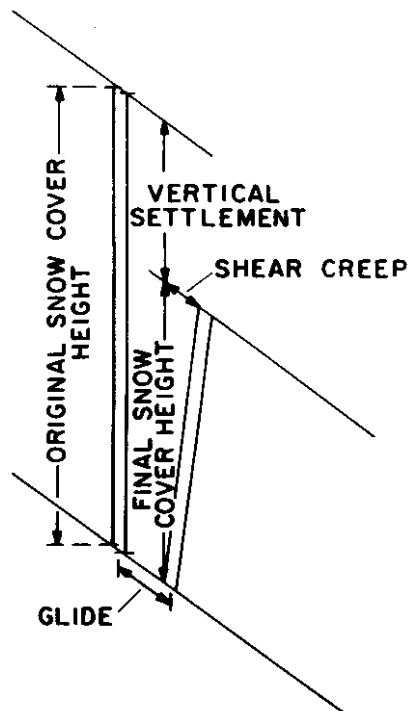

Figure 2. Typical creep experiment, Mt. Baker Site 3.

DURATION OF EXPERIMENT:

5.087×10^6 sec (\approx 2 MONTHS)

SHEAR CREEP: 1.497×10^{-6} cm/sec

GLIDE: 0.2295×10^{-6} cm/sec

ORIGINAL HEIGHT: 422 cm

FINAL HEIGHT: 156 cm

SLOPE ANGLE: 30° , SOUTH-SOUTHWEST FACING SLOPE

TERRAIN: SHORT BRUSH AND GRASS

Glide Material

The glide boundary condition occurring with thermal and mechanical equilibrium appears to result in a uniform glide speed. At any time the total normal interface area, A , will be comprised of fluid and solid parts (A_F and A_S), thus

$$A = A_F + A_S \quad [4]$$

The area A_F may in fact include separated interface regions discussed by Lang and Brown (1973). The only requirement is that A_F is unable to sustain shear stresses; then the apparent shear stress during glide is

$$\tau = \frac{\tau_s A_S}{A} \quad [5]$$

where τ_s is the shear strength of the snow in the region A_F . This has a likeness to the Bowden-Tabor (1958) hypotheses. The area A_S will depend not only on the melting and freezing on the interface but also on the snow column weight. This affects the normal contact force on the sintered material considered here. An increase in normal force increases the contact area (\bar{A}_S) and results in a higher tangential force to cause incipient rigid body slip. Thus if N is the normal contact force, T the tangential force at the contact between two spheres at incipient slip, then

$$T = \mu_s N \quad [6]$$

and

$$\tau_s = \frac{T}{\bar{A}_S} \quad [7]$$

Because the increase in \bar{A}_S with N is nonlinear, it is apparent that the value of τ in [5] is not only sensitive to the thermal state but also depends on the weight of the snow overburden. The importance of these aspects will vary from site to site.

A steady situation later in the season would be expected to produce an isothermal state, non-modifying snow properties and fixed snow overburden. A possible relationship at this steady state between the interface apparent shear, τ , and the finite glide speed v is

$$\tau = B v^{-1} \quad [8]$$

where v depends on A_S/A and B on the local conditions providing the values in [6] and [7].

Creep Model

Consideration of the material suggests that tractable problems in snow mechanics are generally of two types: (1) Those in which disturbances are of short duration and behavior is essentially elastic, and (2) those where loads are sustained for longer times and viscous flow is significant compared to initial elastic motions. For type (1) indications are that at least for low stresses a linear elastic law may be justifiable (Brown et al. 1972). For type (2), consideration of the material as either nonlinear or inhomogeneous lead to motions consistent with those observed. These two forms of steady creep law are investigated here.

For this purpose we will assume uniform slope and snow depth and constant snow density, ρ . Coordinates are as shown in figure 3 where an infinite extent in the x_2 plane exists. Then the known stress components, τ_{ij} , (Brown et al. 1972) are:

$$\tau_{12} = \rho \sin \theta x_2 \quad [9a]$$

$$\tau_{22} = -\rho \cos \theta x_2 \quad [9b]$$

$$\tau_{13} = \tau_{23} = 0 \quad [9c]$$

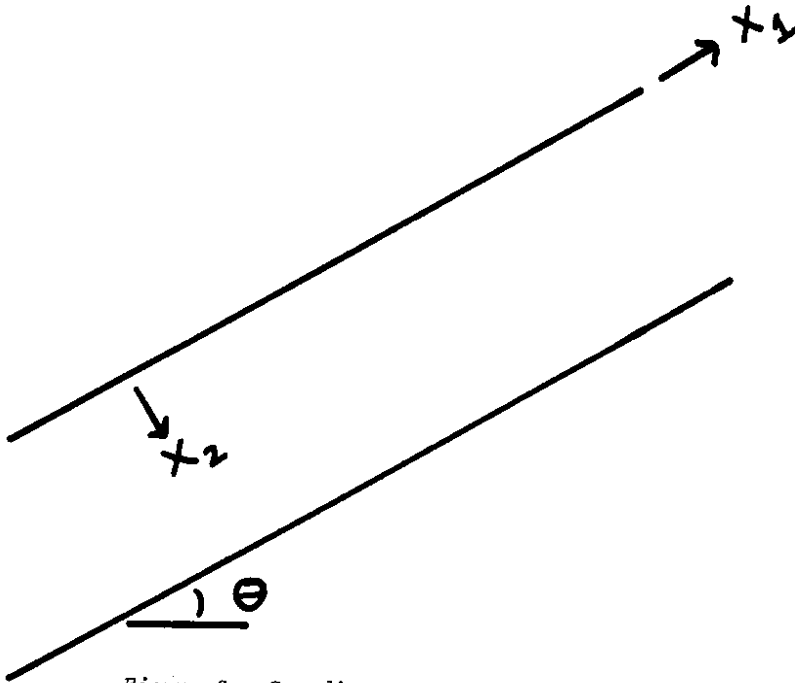

Figure 3. Coordinate system for creep model of long uniform slope.

Known strain rate components, d_{ij} , are:

$$d_{12} = k_1 \quad [10a]$$

$$d_{11} = d_{33} = d_{13} = d_{23} = 0 \quad [10b]$$

based on our experimental evidence (figure 2), we assume k_1 is constant.

Thus only d_{22} , τ_{11} , and τ_{22} are unknown.

(a) Nonlinear Isotropic Constitutive Law.--

To model an isotropic homogeneous relation between stress and strain rate for steady creep, we assume a constitutive law of the form (Salm 1967):

$$\tau_{ij} = F_1 \delta_{ij} + F_2 d_{ij} \quad [11]$$

where F_1 and F_2 are functions of the independent strain rate invariants I_1 and I_2 and where

$$I_1 = d_{kk} \quad [12]$$

$$I_2 = \frac{1}{2} d_{ij} d_{ij} \quad [13]$$

From [10], for the state of deformation under consideration,

$$I_1 = d_{22} \quad [14]$$

$$I_2 = d_{22}^2 + 2k_1^2 \quad [15]$$

From [11]

$$\tau_{12} = F_2 k_1 \quad [16]$$

which, using [9a] and [10a], give

$$F_2(d_{22}, d_{22}^2 + 2k_1^2) = \frac{\rho \sin \theta}{k_1} x_2 \quad [17]$$

Clearly, the dependence of τ_{22} on x_2 must be known before proceeding further. This information is not presently available, however, and the general relation $\tau_{22}(x_2)$ will be assumed. It may readily be shown that [17] cannot be satisfied if d_{22} is constant. Assuming

$$d_{22} = k_2 x_2 \quad [18]$$

where k_2 is constant, then [17] can be most simply satisfied if

$$F_2(I_1, I_2) = \alpha I_1 \quad [19]$$

where α is a material constant.

Satisfaction of [9b] places restrictions on F_1 which using [11] become

$$-\rho \cos \theta x_2 = F_1 + \alpha (k_2 x_2)^2 \quad [20]$$

[20] is most simply satisfied if

$$F_1(I_1, I_2) = \beta I_1 - \alpha I_1^2 \quad [21]$$

and hence the simplest form of [11] consistent with observations is

$$\tau_{ij} = (\beta d_{kk} - \alpha d_{kk}^2) \delta_{ij} + \alpha d_{kk} d_{ij} \quad [22]$$

and in terms of α and β the parameters of deformation, k_1 and k_2 , are given by

$$k_1 = -\frac{\beta}{\alpha} \tan \Theta \quad [23]$$

$$k_2 = -\frac{\rho \sin \Theta}{\beta} \quad [24]$$

(b) Inhomogeneous Constitutive Law.--The observed shearing deformation will occur if

$$\tau_{12} = 2\Sigma d_{12} \quad [25]$$

where Σ is a material constant which increases linearly with depth and is zero on the upper surface. Such inhomogeneity would result if the flow law for steady creep were of the form

$$\tau_{ij} = \lambda \delta_{ij} + 2\Sigma d_{ij} \quad [26]$$

where λ and Σ are material constants which depend on invariants of the state of strain, that is, stress-induced inhomogeneity. The observed deformation would occur if Σ were linear in volumetric strain (or hydrostatic stress).

Argument (b) for inhomogeneous material provides a simpler explanation of the observed shearing motion than argument (a). For this reason, it must be preferred at this stage. Provided that λ and Σ are strain or stress dependent, then [26] still describes nonlinear material behavior. For some stages of creep, however, where the state of stress remains constant, the behavior will be equivalent to that of an inhomogeneous isotropic material. Clearly, further experimental evidence is required before more definite conclusions may be drawn with regard to the constitutive law for steady creep.

Avalanche Prediction

From the hypothesis of Perla and LaChapelle (1970) and the subsequent full analyses (Gand and Zupancic 1965), it is clear that one avenue of avalanche prediction concerns the attenuation of basal shear capacity. The regelation model suggested here for the steady speed case would mean that over a substantial total interface area A some part will be melted and some frozen. Additionally, separation may occur. Under these circumstances [4] and [5] apply. Over A_F the shear capacity will be zero whereas over A_S the capacity at incipient sliding will be τ_F . This will reduce when a value $\mu_k \leq \mu \leq \mu_s$ is introduced into [6]. Averaged over the interface, this will account for some regions slipping locally and some just on the point of slipping. A consequence is that as A_S/A decreases, the apparent shear capacity, τ , decreases and the glide speed increases. Thus the physical model for glide resistance of Gand and Zupancic (1965) and by figure 1 can be explained by the hypothesis of [5]. In this case, our interest is in the sense of the ratio A_S/A and hence in the sign of the rate of change of glide speed with respect to time. When the glide speed is increasing, with no additional evidence of increase in snow strength, then conditions of incipient avalanching should be expected. With decreasing glide speed, the slope should be stabilizing. In figure 1 the increasing glide speeds in February forecast periods of danger because of the increase in A_F ; the decreasing speeds in February and March give rise to confidence in the snow slope stability.

Acknowledgments

This work was sponsored by the Federal Highway Administration, U. S. Department of Transportation, and the Department of Highways, State of Washington. The opinions, findings and conclusions expressed are those of the authors and not necessarily those of the sponsors.

Literature Cited

- Bowden, F. P., and D. Tabor.
1958. The friction and lubrication of solids. Oxford Univ. Press.
- Brown, C. B., R. J. Evans, and E. R. LaChapelle.
1972. Slab avalanching and the state of stress in fallen snow. *J. Geophys. Res.* 77:4570-4580.
- Gand, H. R., and M. Zupancic.
1965. Snow gliding and avalanches. *Int. Symp. Sci. Aspects of Snow and Ice Avalanches*, Davos, Switz., p. 230-242.
- Lang, T. E., and R. L. Brown.
1973. On the mechanics of the hard slab avalanche. p. 24-28. In *Advances in North American avalanche technology: 1972 symposium*. USDA For. Serv. Gen. Tech. Rep. RM-3, 54 p. Rocky Mt. For. and Range Exp. Stn., Fort Collins, Colo.
- Perla, R. I., and E. R. LaChapelle.
1970. A theory of snow slab failure. *J. Geophys. Res.* 75:7619-7627.
- Rowe, G. W.
1964. Friction and metal-transfer of heavily-deformed sliders; mechanisms of solid friction. Elsevier Pub. Co., N.Y., p. 204-216.
- Salm, B.
1967. An attempt to clarify triaxial creep mechanics of snow. In *Physics of snow and ice*, Hirobumi Ōura, Ed. *Int. Conf. Low Temp. Sci.* [Sappora, Japan, Aug. 1966] Proc., Vol. I, Part 2, p. 857-874. *Inst. Low Temp. Sci., Hokkaido Univ.*

AVALANCHES AND SYNOPTIC WEATHER SITUATIONS IN THE CASCADES
DURING THE WINTERS OF 1971-72 AND 1972-73

By Terence Fox

Purpose of the Study

This study was undertaken with the purpose of identifying observable synoptic scale weather patterns, and the sequential variation of meteorological variables produced by these patterns, which may be associated with periods of extensive avalanche release in the Washington Cascades. Some attention was devoted to the relative timing of meteorological events and avalanche release, and to the geographic variation of the weather conditions and slide activity during these periods.

Sources of Information

In order to carry out these investigations, communications were established with a number of observing stations in the Washington Cascades during the 1971-72 winter. Information on snowfall, temperature, winds, and weather and sky cover, as well as reports of natural and artificial avalanches, were received daily from these stations. Information from two additional stations was received at the end of the winter from the Alpine Snow and Avalanche Research Project of the U.S. Forest Service, and the data from the other areas were made more complete. The locations of the observing stations are shown in Figure 1, and the observations made at each are detailed in Table 1.

The winter's natural and artificial avalanche record from nine areas in the Cascades, compiled from U.S. Forest Service and Washington State Highway Department records, is presented in Figure 2. Five periods of severe and widespread natural avalanching were identified from these data (January 10-11,

January 18-21, February 12-18, February 27-28, March 4-6), and the weather situations affecting the Cascades at these times were examined in detail.

Results of the Investigations: Winter 1971-72

Before discussing the results of this study, it is emphasized that the particular winter under consideration was one of record snowfalls in the Washington Cascades, and of extreme amounts of avalanche activity. This allowed great opportunities for investigation of the circumstances surrounding avalanche occurrence. It also, however, necessitates the use of caution in reviewing the conclusions, inasmuch as the conditions which led to the release of such large amounts of avalanching may have been themselves extreme, and possibly not typical of common winter situations in the Cascades.

The basic sequence of events which has been known to be associated with avalanching in the Washington Cascades, that of substantial snowfall followed by a warming to temperatures near or above freezing, was a dominant feature of each of the five major periods of natural slide activity. In most cases, the initiation of slide activity coincided with the time of the warming, indicating that the rapid rise in temperature may have been genetically connected with the first slides. In particular cases, a geographic progression of the initiation of avalanche activity appeared to be associated with a similar progression of the initial warming.

Although the initiation and in most cases a substantial portion of the avalanching was apparently related to the initial temperature rise in these situations, in every case of serious slide activity the avalanches continued to occur well after the arrival of the warm air, and well after the initiation of the activity itself. That this was true was probably a major factor allowing the release of so many slides in these cycles, in that favorable conditions

for the release of slides persisted for a long enough period of time to allow more avalanche activity to take place. In each of the cases studied, the initial warming was followed by a period of continuing precipitation at temperatures which remained relatively warm, and avalanching continued to occur throughout this period. In some cases this later avalanching appeared to come as rather definite time groupings of activity. These secondary groups of slides may have been associated with some secondary atmospheric warming, which were small in magnitude but possibly large in geographic scale.

The evidence from all of the cases indicated that, as long as significant precipitation continued at warm temperatures (warm meaning that temperatures at the elevations of slide release zones were near freezing), the possibility of avalanche release was high. The chance of small increases in the snow-rain elevation allowing rain to fall on large amounts of newly deposited snow was always present in these situations. This, together with the additional loading and possible lubricating effects of the rain on the snow pack at lower elevations apparently led to the continuing slide activity.

This meteorological sequence, the large snowfall ahead of a rapid rise in temperature, followed by an extended period of continuing precipitation at warm temperatures, was produced by a variety of synoptic weather situations in the cases studied. The most common situation was that of an intense, maturing warm front - cold front system, with a definite warm sector present as it passed through the Cascades. In each of the cycles of January 11, February 16, and March 5, the new snow ahead of the warm front fell on substantial amounts of snow which had been deposited in the previous two or three days by preceding systems. Fairly intense orographic precipitation continued in the Cascades while the warm sector was present, as relatively strong westerly winds responded

to the intense pressure gradients of these storms.

As an example, the January 11 cycle will be discussed in detail. Table 2 details the natural avalanche activity in this cycle. The activity in the main cycle began late on the 10th, and was essentially completed by 0900 Pacific Standard Time (PST) on the 11th, although two large natural slides were released later in the day.

The passage through Washington on January 8 of a frontal system was followed by 20 to 30 mile-per-hour westerly pass-level winds which persisted through the 9th and 10th in association with a strong upper level west-north-westerly jet stream and a sharp surface lee side trough east of the Cascades. Substantial precipitation fell throughout the state ahead of the frontal system, and continued at the mountain stations (except at Mission Ridge) in the two days following its passage as the persistent low level westerly current produced orographic precipitation in these areas. Because the freezing level remained below 4000 feet, the precipitation was entirely in the form of snow, with the result (detailed in Fig. 3) that there was substantial new snow reported on the mornings of the 8th, 9th, and 10th.

Fig. 3 also suggests that temperatures, which were at or below freezing everywhere except Mission Ridge during these three days, generally trended downward through the morning of the 10th.

Referring to the Avalanche Occurrence Record in Fig. 2, it is seen that a minor natural avalanche cycle affected a few areas on January 8, in association with the frontal system of that day. On the 9th and 10th, although there was some artificial avalanche release in a few areas, natural release was minimal despite the substantial new snow which was accumulating.

The evening of the 10th and early morning of the 11th saw a strong short

wave in the northwesterly upper level flow, and an associated surface system with a distinct warm front and cold front, move through the state. The progression of the surface system is shown in Fig. 4. Precipitation from this system, though substantial in most areas of western Washington, was especially great in the Cascades, where amounts of liquid water equivalent of the new snow were generally reported greater than two inches (including Mission Ridge). As Fig. 3 indicates, new snow totals on the morning of the 11th were correspondingly high. (Note that the Crystal Mountain and Stevens Pass readings are daily snowfall averaged over two days ending the morning of the 12th, since avalanche clean-up took priority over the recording of weather data on the 11th.) Alpentel, apparently warmer because of its relatively low elevation, received a portion of its precipitation from this system in the form of rain, accounting for the lesser new snow total measured there.

Fig. 3 also shows that the morning temperature on the 11th measured a short while after the times of release of the slides, rose from the previous day, reflecting the presence of the warm sector of the system.

The warm front itself was a rapidly moving one, with a relatively steep slope. Temperature rises from its passage at the surface were on the order of 10°F. As Fig. 5 shows, the rises were sharpest at the coastal stations, but more gradual inland due to the disruptive effects of topography on the flow of the air. In western Washington the warm air flowed northward up the Puget Sound basin, and eastward down the Strait of Juan De Fuca, with these two streams merging around midnight northeast of the Olympic mountain range. It entered eastern Washington through the Columbia River gap, affecting first those stations in the southeast, and later mixing northward (see Pendleton, Spokane, Yakima, and Wenatchee in Fig. 5). A freezing rain report from Wenatchee at 0200 PST

on the 11th indicated the presence of warm air aloft just east of the Cascades, hours before its arrival at the surface.

The best detailed sequential record of the effects of the system in the Cascades comes from Stampede Pass, which warmed during the night from 23°F to 31°F with the passage of the warm front. An additional warming between 0500 and 0700 PST, 6 to 8 hours ahead of the cold front, brought above freezing temperatures and some rain mixed with the snow, with the rain persisting for three hours. Precipitation continued to be intense during this period. It is noted that the pass winds there, which had been strong westerly in the preceding two days, had nearly died by 1900 PST on the 10th in response to the approaching system, indicating a shift to an easterly pass wind may have taken place later in the night, before becoming again strong westerly by 0400 PST the morning of the 11th.

That there is a time relationship between the arrival and presence of the warm air and the release of the slides is obvious. The avalanches occurred on the night of the 10th and the morning of the 11th. Fig. 5 shows the warm air reached the coast at the surface by 1800 PST on the 10th (Hoquiam), was pushing into the Puget Sound basin at the surface by 2100 PST (Seattle, Olympia), and was into eastern Washington, and near the east slopes of the Cascades, by 0200 PST (temperature rise at Yakima, freezing rain first reported at Wenatchee). The trailing cold front moved through the region in the early afternoon of the 11th. Nearly all of the avalanches for which approximate times were given occurred during the period between the two fronts, when the warm air was present.

There is a rough indication from the release times which were given for some of the Snoqualmie Pass and Stevens Pass slides in Table 2 that the avalanching may have occurred in two major time groupings. The first group includes all those released between 2100 PST on the 10th and 0330 PST on the 11th,

apparently within a few hours of the arrival of the warm air in the Cascades. The second group, between 0600 and 0815 PST on the 11th, may have occurred with a slight additional warming of the atmosphere. Evidence of this secondary warming is found in the temperature records of Fig. 5, specifically at Seattle (between 0200 and 0500 PST), and less definitely at Bellingham (between 0100 and 0200), and at Olympia (between 0100 and 0500). In the Cascades, the beginning of rain at Stampede Pass at 0650 PST demonstrates the effect this warming had on the snow-rain level in the mountains.

The February 16 and March 5 storms displayed a similar warm front - warm sector - cold front pattern, but were generally warmer than the January 11 system. Rain was reported while the warm sector was present in most mountain areas from the two later systems, and substantial amounts of liquid water was deposited into the snow pack. In these particular cases, wet natural avalanching occurred after the passage of the cold fronts in these systems (on February 17 and March 6), when the air temperature had again become well below freezing. Three sets of conditions may have contributed to the occurrence of these slides. The most important was the presence of large amounts of liquid water in the snowpack, which had been deposited during intensive warm sector rainfall on the previous day. The second was the rapid cooling of the surface snow layers by the colder air, which may have altered the mechanical properties of these layers with respect to the warmer underlying snow. Third was the additional loading from new snow which was falling at the time of slide release. Synoptically, the essential aspect of these delayed action avalanches was again the extended presence of the warm sector of the preceding systems, which allowed the large amounts of rain to fall in the slide release zones.

The other two cases of major widespread avalanching occurred under

slightly different synoptic situations. A frontal system in each case brought the initial rise in temperatures, but both times warm precipitation continued as a low pressure area which had remained west of Vancouver Island to produce a warm moist flow over the Cascades during the following 36 to 48 hours. In both cases evidence suggested that an additional atmospheric warming during this period of warm precipitation, which was small in magnitude but large in geographic scale, may have been associated with much of the additional avalanching. The freezing level record on February 26-29, with the period of natural avalanching indicated, is shown in Fig. 6. It is seen that the natural slide activity took place while the freezing level was above about 4000 feet, in the warm period between the two systems.

Aside from the afore-mentioned cycles of February 17 and March 6, natural avalanching was minimal during cooling trends even when substantial snow was being deposited. (Artificial triggering of slides was often quite successful at these times.) An example of such a period is January 21 through 24.

Although new snowfall was heavy and total snow depths increased substantially, Fig. 2 shows that natural activity was minimal or nonexistent throughout the Cascades. The downward trend in the Stevens Pass temperature record in this period was typical of most of the Cascade station records.

Another period of large snowfall but minimal activity during a cooling trend was that of January 9 and 10 (see Figures 2, 3). In this case the lack of avalanching only served to allow the snow to build up, resulting in larger slides when they were finally released with the intensive warm front on the 11th.

Weather and Avalanches in 1972-73

In contrast to the previous year, snowfall in the Cascades during the 1972-73 winter was well below normal, as a recurring split upper level flow pattern tended to divert much of the intense storm activity to the north and to the south of Washington State. There was also significantly less avalanche activity, and there were no cycles which approached in severity any of the five serious cycles in the previous winter.

Probably the most severe and widespread cycle occurred late on the night of December 25 and on the morning of December 26. These slides were associated with rain from the warm sector of a frontal system which passed quickly through the state at that time. This was the most well-defined open warm front - cold front system of the winter.

During January 12 through 14, 1973, another period of natural avalanche activity occurred when a series of occluded fronts brought precipitation and gradually warming temperatures throughout the period. Rain occurred in many areas on the 13th and 14th.

Two separate invasions of cold, dry arctic air produced a different kind of avalanche condition. Strong pressure gradients associated with an arctic high pressure area northeast of the region produced, at Washington Pass and at Stevens Pass, prolonged periods of strong easterly winds which formed wind slab conditions at these times. The release of avalanches in these situations was in some cases independent of any frontal activity. In other cases, new snow or warming, as the arctic high pressure broke down, apparently weakened these slab layers, producing slides.

Most of the avalanches in these cycles, and in the entire winter in general, were relatively small, due to the absence of intense frontal activity and the

resulting lack of large new snowfall amounts compared with those recorded the previous winter.

Discussion

Although the results of this study are obviously quite preliminary, some immediate suggestions for applications arise in terms of monitoring these phenomena for the ultimate purpose of avalanche prediction and/or control. Specifically, the role of the observational network, employed in this study in an informal way, must be considered.

For this work, the network was an informal one, which made use of the existing Alpine Snow and Avalanche Research Project of the U.S. Forest Service, plus Highway Department, Park Service and University of Washington observers. Data from each station were received and compiled daily at the University of Washington. The daily centralized collection of data was made possible through the cooperation of U.S. Forest Service and U.S. Park Service personnel, of ski area management, and of Washington State Highway Department personnel.

The procedure used to transfer data varied with the situation at each observing station. In most cases, the observer recorded the information in standardized form and transferred it to an office. The data were later relayed from the office by phone. The time of day when each area was contacted varied from area to area, and depended on the daily schedules of observers and office staff. Usually the data were obtained within a few hours of the observations. No transfer of data took place on weekends, and the weekend observations were transferred each Monday, along with that morning's observations.

In the 1972-73 winter the data collection program was again implemented.

Changes from the previous year included the addition of twice-a-day reports from an observer living at Washington Pass, and closer and more frequent communication with the Washington State Highway Department's avalanche control and research program at Stevens Pass. Twice each day, weather analyses and forecasts were prepared for both of these areas, and transmitted as their data was received.

This procedural setup was adequate for the purposes of the present study. In terms of further research, and especially in attempting to use the network for avalanche control and prediction purposes, its informal nature would lead to obvious inadequacies. The most important of these is in the communication of data. Because of the program's relatively low priority as an extra duty of many of the observers, the times of observations and of their transfer to a location which could be reached by phone varied from day to day. This, along with the rather involved data transfer procedure itself, produced a considerable lag between the time of observation and the time that the information was finally received at the University of Washington. In an operational situation, the data so obtained would have value, but its usefulness would be restricted by this sizable time lag, especially in conditions of rapidly developing slide hazard.

Another problem with this procedural setup, in the case where the data is transferred by an intermediate person such as a secretary, is that there is no chance for immediate clarification of questions concerning the data, and dialog between observer and receiver is necessarily restricted. This may result in less precise information exchange, and restricts the feedback of special weather information to the observer, which might be required in particular situations. This would be a serious handicap to an operational program

at times of developing hazard.

The once-a-day frequency of observation and data acquisition was adequate for the purposes of this study. In an operational avalanche forecasting and control program, more frequent transfer of information, especially of such items as new snowfall, temperature, the form of precipitation, and avalanche occurrence, would be of obvious value at times of developing avalanche hazard. The operating schedule of a ski area makes the addition of these extra observations to a snow ranger's duties impractical. However, the 24-hour patrol of Cascade Highway passes by Highway Department personnel does present a possible means by which more frequent observations could be handled. Communications might also be simplified by making use of existing Highway Department facilities. The once-a-day reports from ski areas would still be a valuable supplement to this information.

The value of a two-way exchange of information (weather data from Highway Department observers in exchange for weather analyses and forecasts) was proved in the winter of 1972-73. Such exchange might also be beneficial to snow rangers in charge of avalanche safety in ski areas, and would provide an immediate return from their observational efforts. But this depends again on efficient communication between the parties involved, with specified times for data exchange, so that direct communication with the snow ranger may be possible.

In this study of avalanching and associated weather situations, an apparently high sensitivity of the stability of newly deposited snow to rapid changes in temperature and precipitation is indicated. This suggests that knowledge of the developing large-scale weather situation, combined with direct and immediate information from the release zones of the slides, may be essential in determining the initiation of high avalanche hazard.

An example which demonstrates this occurred in the avalanche cycle of March 4-6, 1972. The passage in the lowlands of western Washington of the warm front associated with this cycle brought considerable precipitation and large temperature rises. From the temperature records of various stations west of the Cascades, presented in Fig. 7, the frontal progression north and eastward can be deduced, with the front passing Astoria between 1700 and 1800 PST on the 4th, and reaching Bellingham by 0200 on the 5th. A thermograph record from an instrument at Washington Pass is shown in Fig. 8. The record ended when the tower on which the thermograph was sitting was hit by an avalanche, burying the instrument. The record shows that a 13°F warming brought the temperature to 30°F, beginning apparently with warm front passage at about 0400 PST, about two hours before the avalanche occurred. The implications with respect to avalanche prediction in this case are obvious.

Since the warm air in a strong warm front can be expected to arrive at higher elevations before it does below, observations on the valley floor may not indicate changing conditions in the release zones above. Remote sensing instrumentation placed near the release zones, especially temperature, wind, and precipitation intensity devices, would obviously be of great value in obtaining this information.

Other specific research needs to be undertaken to determine in each area the local variation of response characteristics to passing frontal systems. Additional needed daily information which would be helpful in this respect includes such things as the time snow or rain begins and ends, times of wind shifts (especially in mountain passes), and the elevation of the snow-rain level.

Further research is also needed to distinguish the effects of warm and

cold precipitation, and of warming versus cooling air temperatures, on the stability of the snow cover and the mechanics of slab avalanche release.

In summary, the results of this study indicated that significant snowfall followed by a rapid rise in temperature and a period of intensive warm precipitation repeatedly led to the release of widespread natural avalanches in the winters of 1971-72 and 1972-73. These conditions resulted from the passage of intensive frontal systems, the distinctive patterns being frontal systems with open warm sectors.

Snow deposited during cooling trends led to noticeably less natural avalanching. Such snow was often susceptible to artificial release or to later natural release under the influence of warm storms. The value of avalanche control procedures in such a situation is clear.

It is obvious that a complete avalanche forecasting and control program in the Washington Cascades must include continuous and direct information on the developing large-scale weather situation. Approximate arrival times of frontal systems, and the duration and intensity of their effects, are key data for avalanche forecasting and control. Direct and rapid communication between different areas in the Cascades, possibly through a central data collection and forecast office, could be of great use in recognizing and controlling avalanche hazard.

TABLE 1

TABLE 1 INDEX OF OBSERVATIONS FROM CASCADE OBSERVING SITES

STATION	elevation (feet)	PRECIPITATION				TEMPERATURE		6-HOUR WIND AVERAGES		PRESENT WEATHER				LENGTH OF RECORD	
		total snow depth	daily new snow	liquid water in new snow	water from rain	precip intensity by 6 hr. periods	maximum-minimum temp at time of observation	20 cm snow depth temperature	direction	speed	wind direction	wind speed	sky cover	weather	from
Paradise	5550	X	X	X	X	X	X			X	X	(X)	(X)	11/ 1/71	4/30/72
Crystal Mountain	4400	X	X	X	X	X	X	X ^a	X ^a	X	X	X	X	12/ 6/71	4/30/72
Stevens Pass	4050	X	X	X	X	X	X	X ^c	X ^c			(X)	(X)	11/ 1/71	4/29/72
Early Winters	2200	X	X	X	X	X	X	(X)	(X)	X	X	X	X	12/ 1/71	3/31/72
Mount Baker	4200	X	X	X	X	X	X	X ^d	X ^d	X	X	X	X	12/ 6/71	5/31/72
Alpental	3200	(X)	(X)	(X)	(X)	(X)	(X)	(X)	(X)					12/ 1/71	3/31/72
Mission Ridge	4600	X	X	X	X	(X)	X ^e	X ^f	X ^f					12/11/71	3/31/72

X - indicates that the observation was made regularly
 (X) - indicates that the observation was made intermittently
 a - The anemometer at Crystal Mountain was on a north-south ridge at an elevation of 6900 feet
 b - Snow temperature record at Stevens Pass and at Early Winters began 12/19/71
 c - From 11/1/71 to 1/30/72, wind speed only was recorded at "Big Chief", elevation 4850 feet. From 1/31/72 to 4/30/72, both speed and direction were recorded, but in a new location, at the top of Chair #5, elevation 4875 feet.
 d - The anemometer in the Mount Baker ski area is on Panorama Dome, at an elevation of 5000 feet.
 e - Snow temperature record at Mission Ridge began 1/1/72
 f - The anemometer at Mission Ridge is at an elevation of 6750 feet.

FIGURE 1

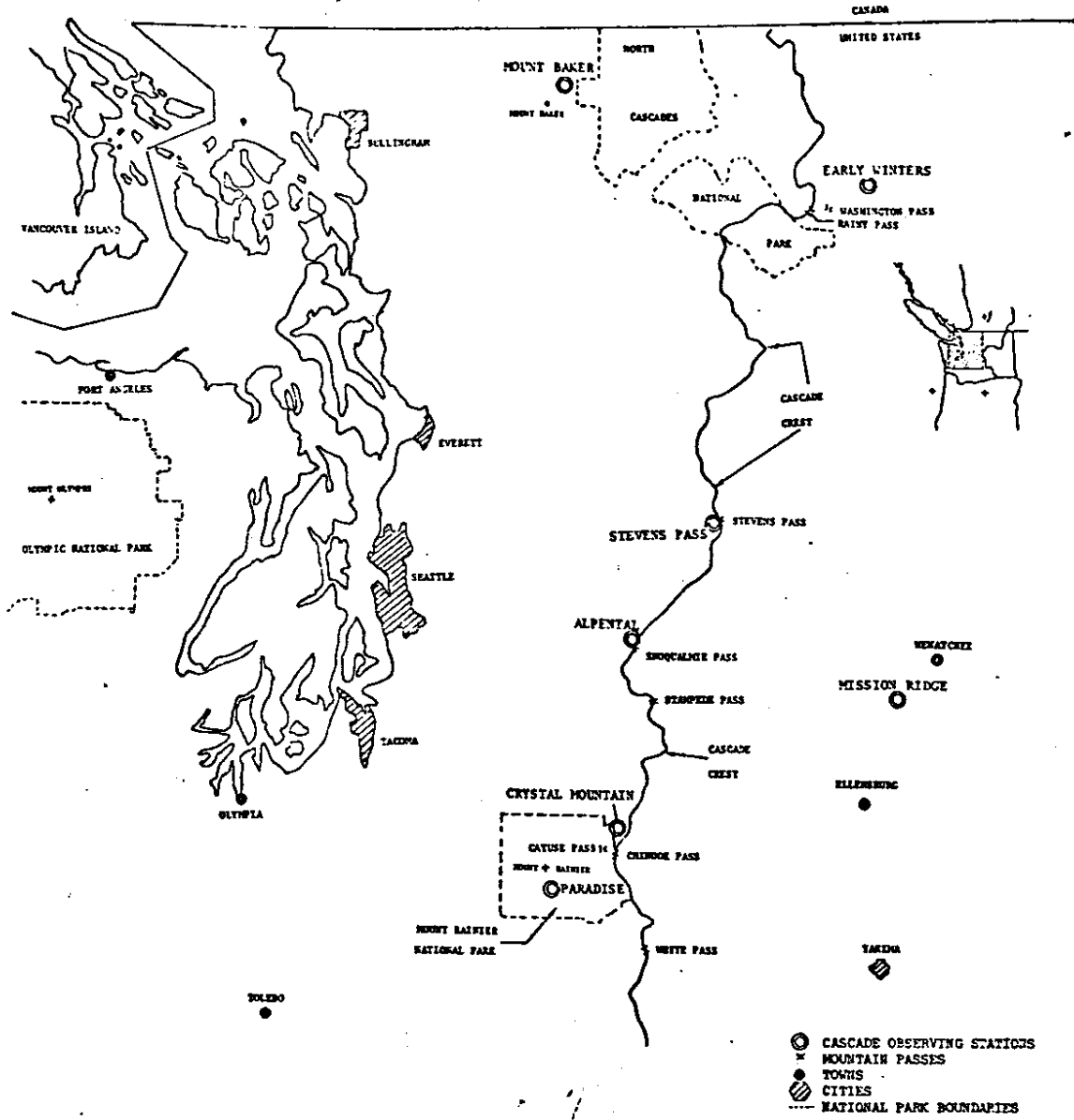

FIGURE 2

WASHINGTON CASCADES AVALANCHE OCCURRENCE RECORD, 1971-72

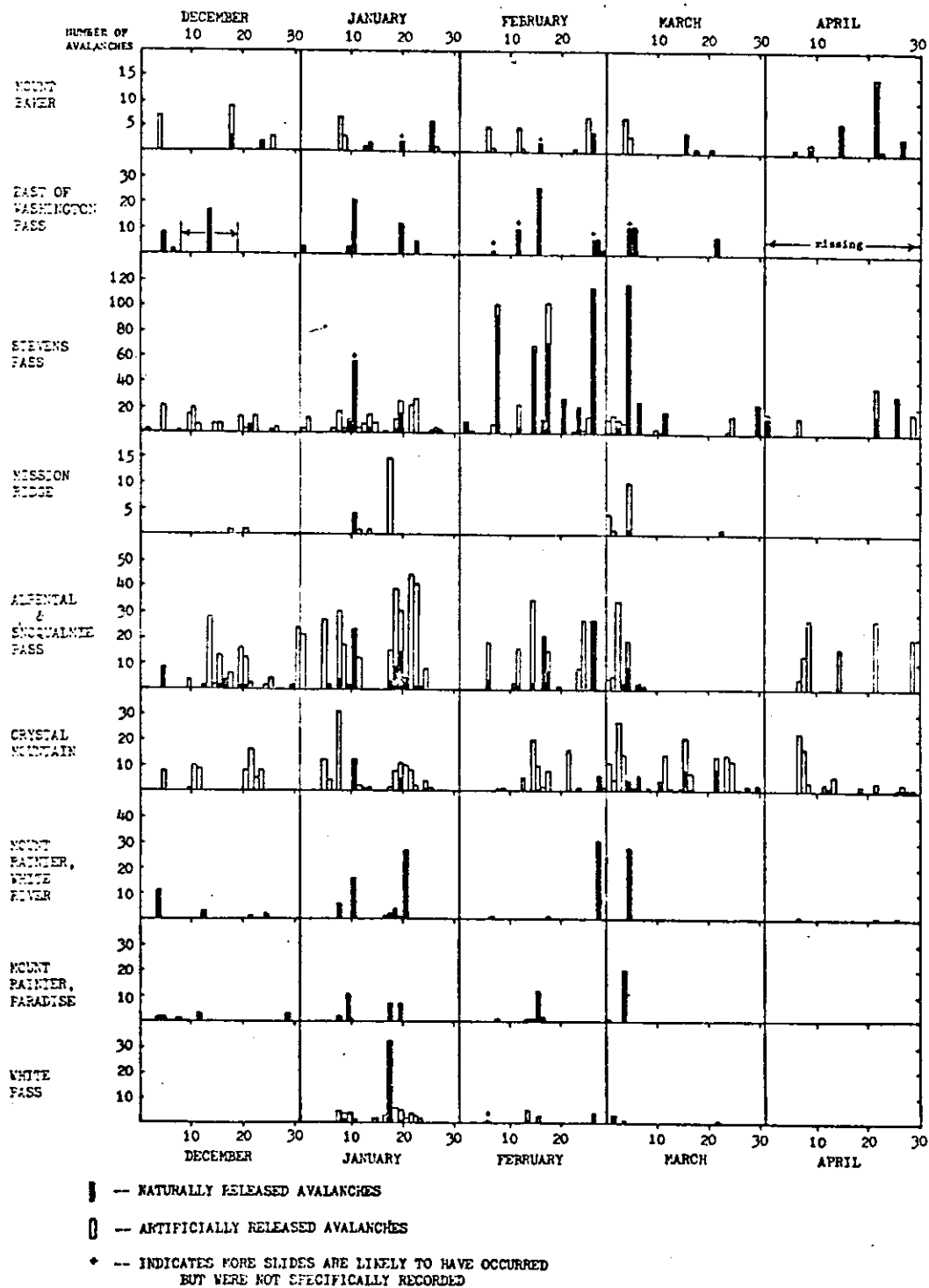

TABLE 2 , NATURAL AVALANCHES IN THE WASHINGTON CASCADES;
 JANUARY 8-11, 1972

<u>Time of Release</u>	<u>Number of Slides</u>	<u>Location</u>
1/8 AM	2	Snoqualmie Pass, I-90; Bandera, Denny Creek
" AM	4	Mount Rainier, White River
" 0345	1	Snoqualmie Pass, I-90; East Snowshed
" 1400	1	Mount Rainier, White River
" 1745	1	Cayuse Pass
" 2240	1	Stevens Pass, US-2; Tunnel Creek
" PM	2	Paradise Road; Glacier Hill
1/9 1640	1	Stevens Pass, US-2 - west
" 2235	1	White Pass, US-12
1/10 Sometime	3	East of Washington Pass; Delancy Ridge
" 0510	1	Snoqualmie Pass, I-90; East Snowshed
" 0800	5	Stevens Pass ski area
" 2110	2	Stevens Pass, US-2; Pole Pile, Berne Camp
" PM	10	Paradise Road
1/11 Sometime	22	East of Washington Pass; Liberty Bell, Cutthroat Ridge, Delancy Ridge
" Sometime	17	Mount Rainier, White River
" AM	12	Crystal Mountain ski area and valley
" AM	13	Alpental

TABLE 2 , (con't)

<u>Time of Release</u>	<u>Number of Slides</u>	<u>Location</u>
1/11 AM	7	Snoqualmie Pass, I-90
" AM	1	Stevens Pass, US-2
" AM	4	Mission Ridge ski area
" 0000	1	Stevens Pass, US-2; Pole Pile
" 0011	1	Snoqualmie Pass, I-90; west of East Snowshed
" 0115	1	Stevens Pass, US-2; Gaynor
" 0145	1	Stevens Pass, US-2; West Camp
" 0330	28	Stevens Pass, US-2; west, Old Faithful
" 0600	1	Snoqualmie Pass; I-90 East Snowshed
" 0601	1	White Pass, US-12
" 0643	1	Snoqualmie Pass, I-90; Lodge Creek
" 0800	1	Stevens Pass, US-2; East Camp
" 0815	20-30	Stevens Pass, US-2; West Camp, Gaynor
" 1300	1	Stevens Pass West; (R.R. trestle)
" 1540	1	Stevens Pass, US-2; Gaynor

FIGURE 3

JANUARY 7-12, 1972; SNOWFALL, TEMPERATURE, AND AVALANCHES

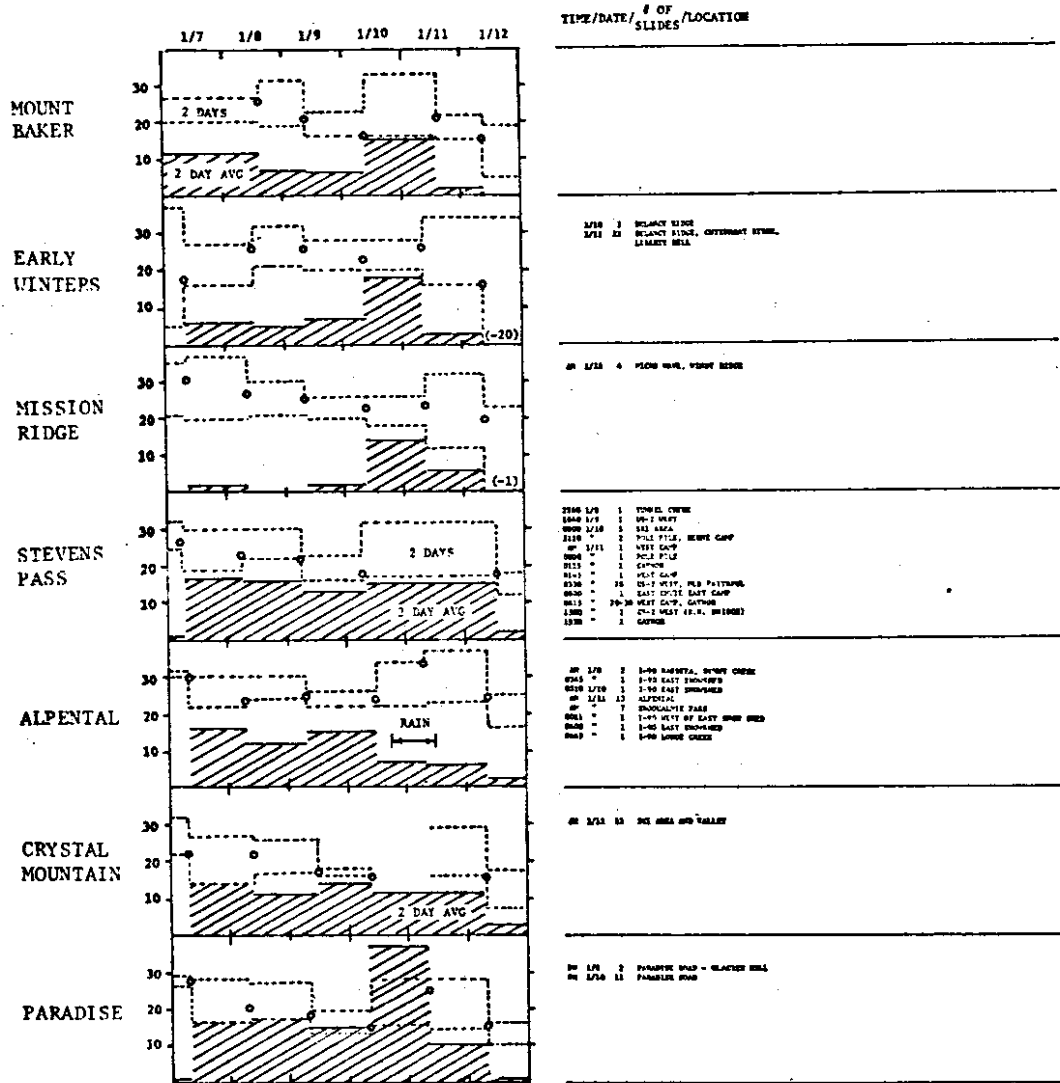

Scale is temperature in °F,
and new snowfall in inches.

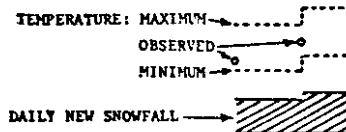

FIGURE 4

JANUARY 10-11, 1972; FRONTAL PROGRESSION

MOUNTAIN OBSERVATION STATIONS •

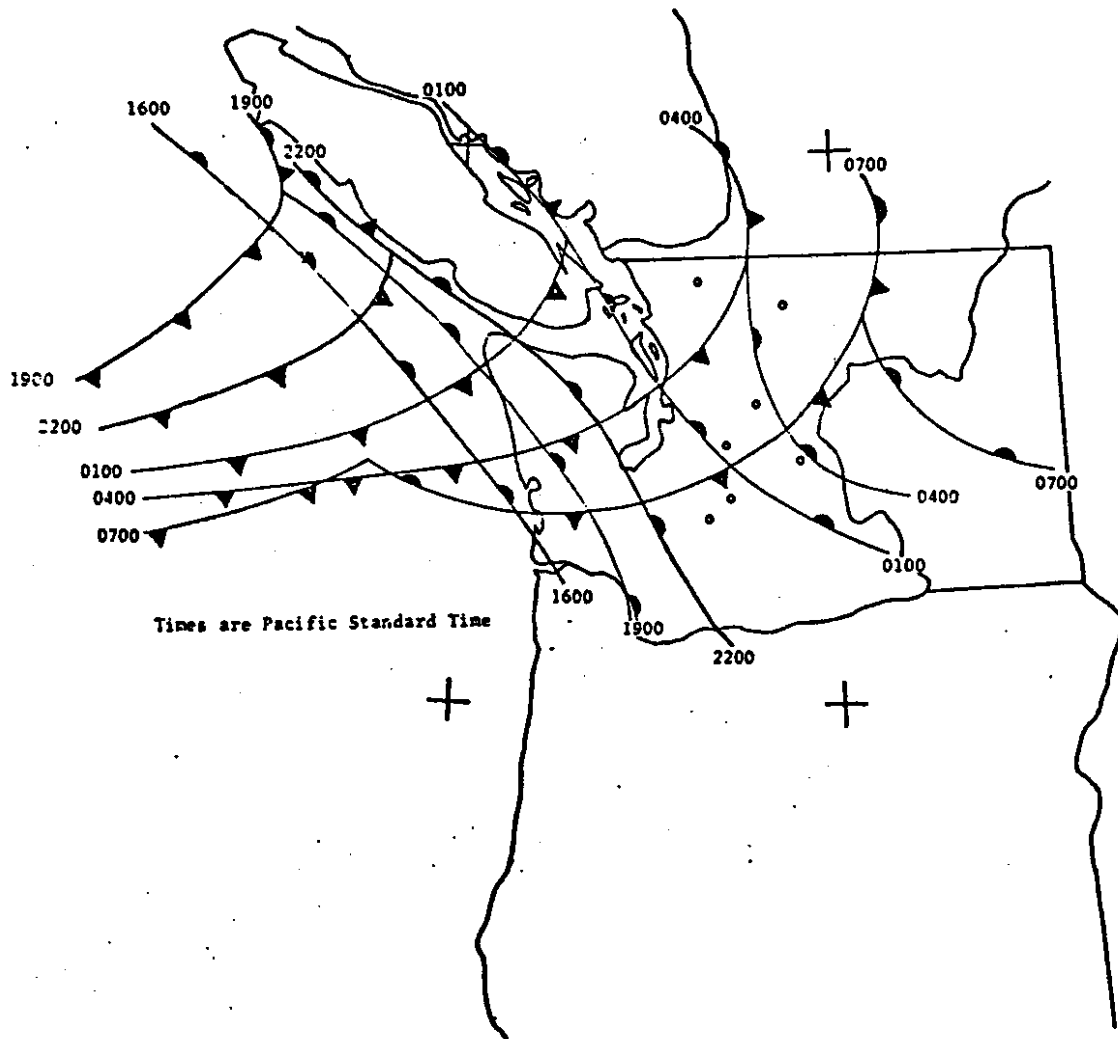

FIGURE 5

HOURLY TEMPERATURE RECORD; JANUARY 10, 11

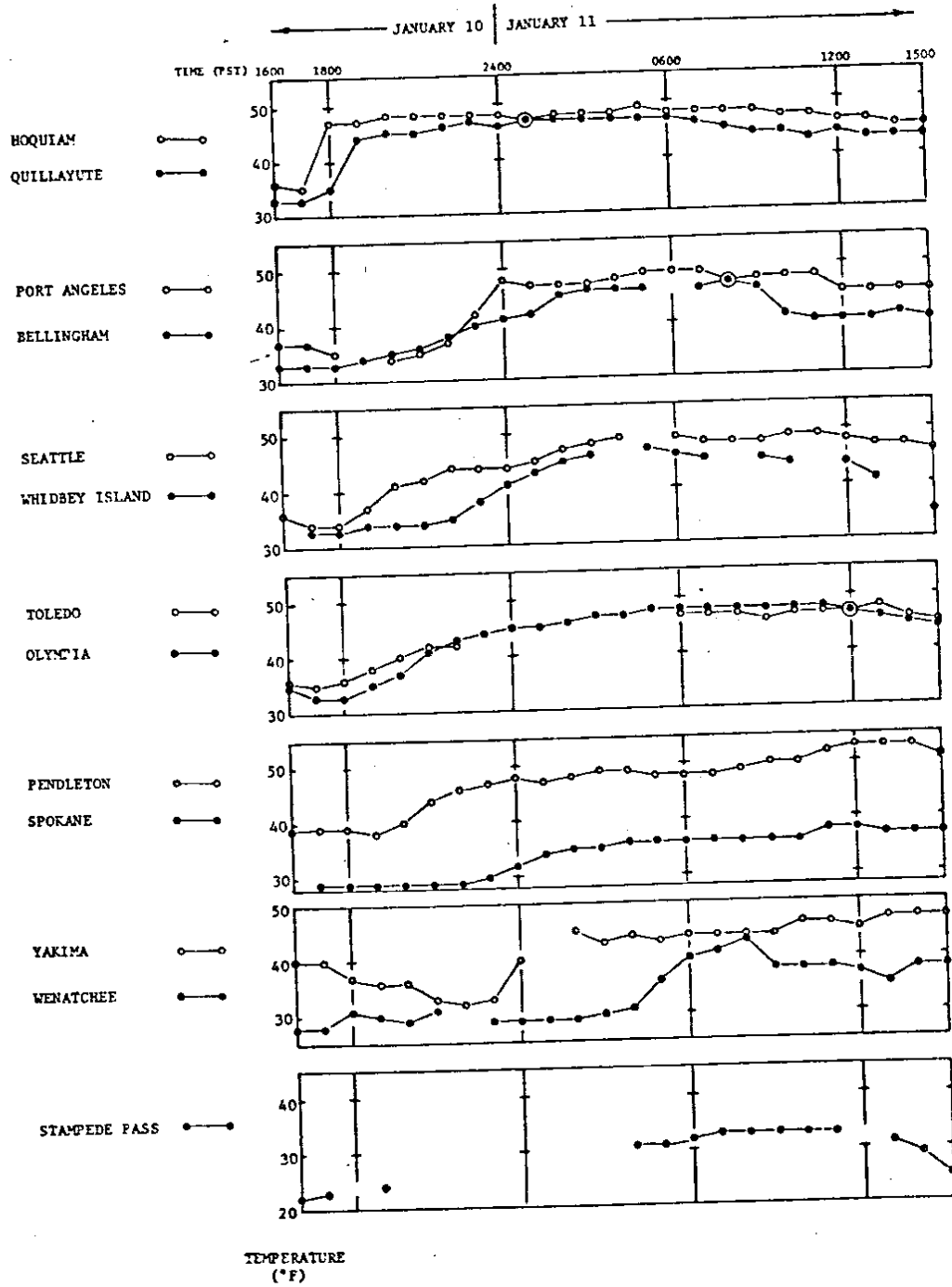

FIGURE 6

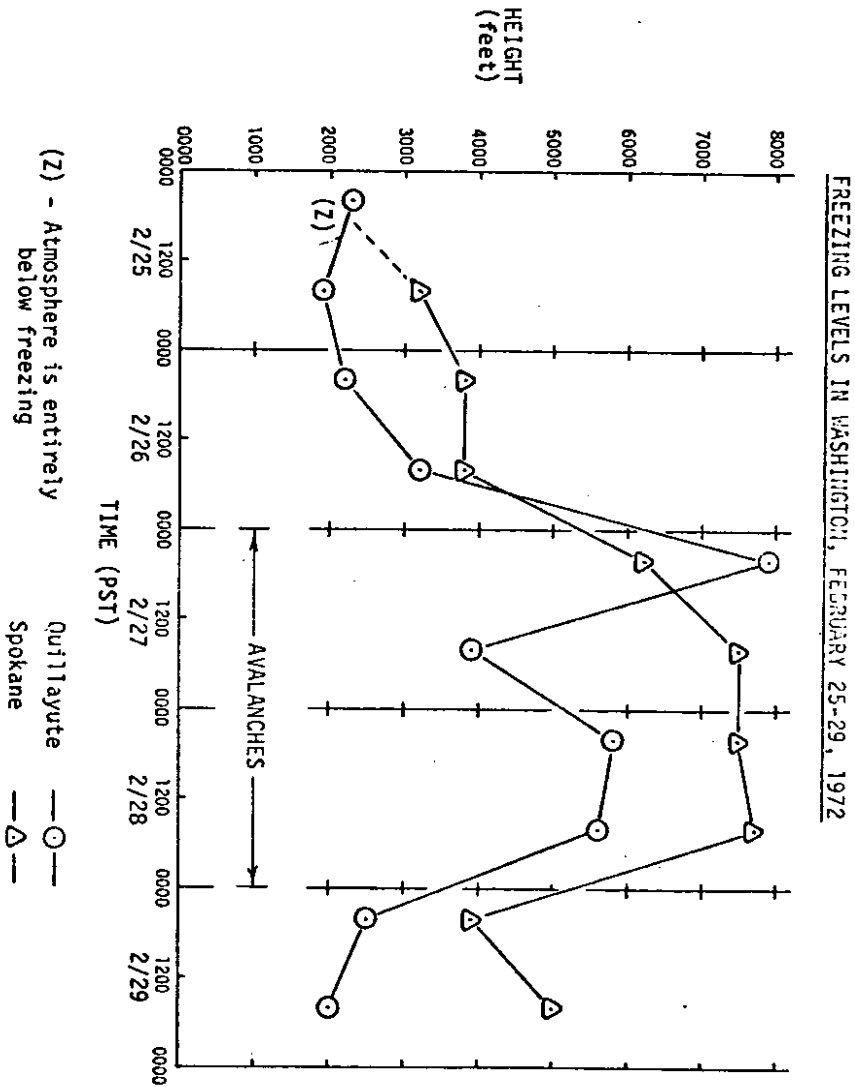

FIGURE 7

LOWLAND HOURLY TEMPERATURE RECORDS WEST OF THE CASCADES; MARCH 4-5, 1972

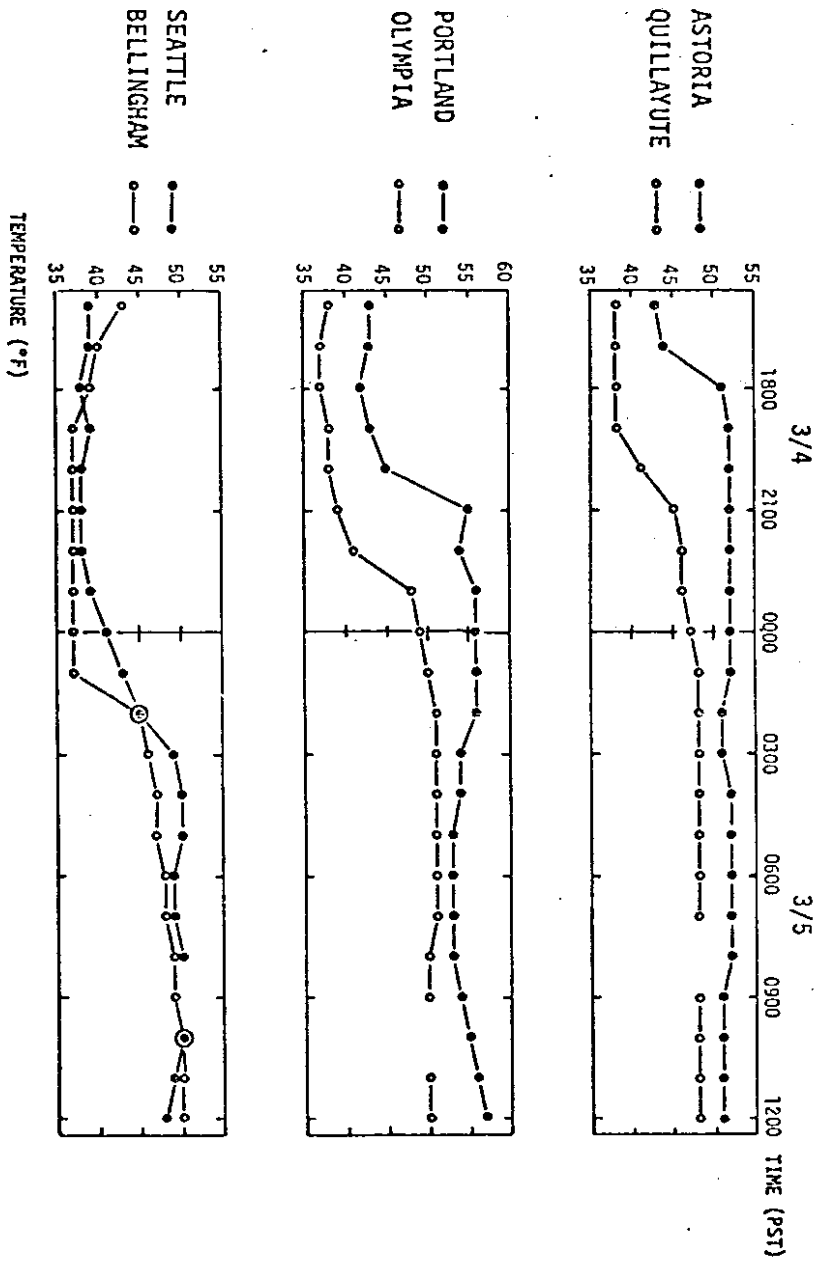
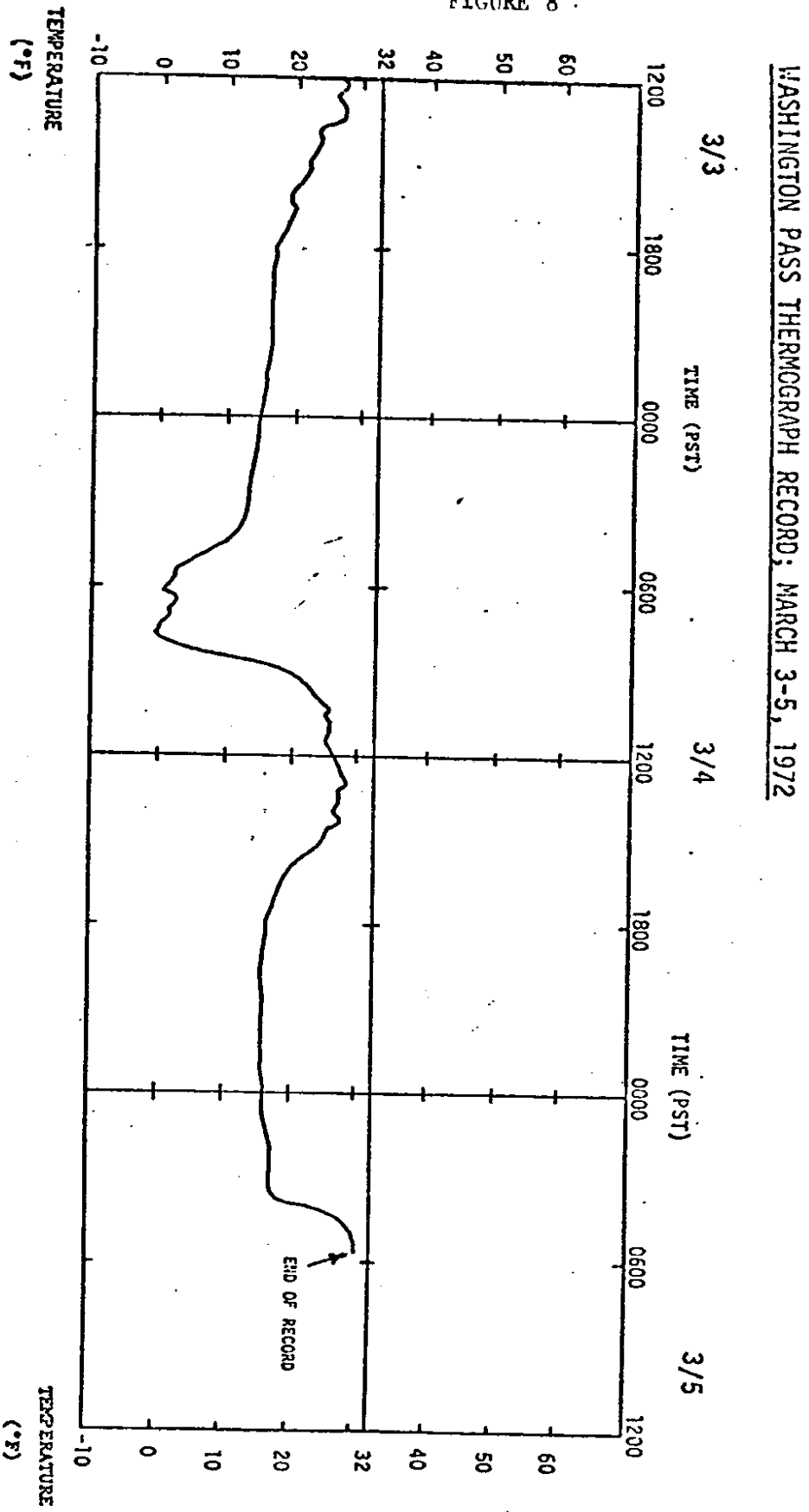

FIGURE 8 .



INDICATION OF SNOW AVALANCHE PERIODICITY THROUGH INTERPRETATION
OF VEGETATION PATTERNS IN THE NORTH CASCADES, WASHINGTON

By Laura Smith

INTRODUCTION

The recent construction and opening of the North Cascade Highway (SR-20) has created an interest in the snow avalanches of the North Cascade Mountains, Washington. Between Newhalem on the west and Mazama on the east, more than eighty avalanche tracks cross the highway. These tracks have been identified, named, photographed aerially, mapped, and their hazard potentials in terms of highway maintenance and public safety have been estimated (Geophysics Program and Department of Civil Engineering, University of Washington, 1971). The only records of avalanche activity in this area of the North Cascades are relatively recent. The data are somewhat incomplete and do not include the entire study area. This investigation is an attempt to obtain an indirect indication of avalanche characteristics and periodicity through interpretation of vegetation patterns on and adjacent to selected avalanche tracks.

The primary objectives of this study were to 1) provide a general description of the characteristics and species composition of vegetation, primarily tree and large shrub species, on and adjacent to selected avalanche tracks, 2) suggest factors responsible for variations in vegetation patterns related to avalanche characteristics and activity, and 3) infer avalanche periodicity and pattern as well as the time of occurrence and extent of past major avalanches using botanical and dendrochronological criteria. Such information, when considered with features of climate and terrain, will provide a broader basis for the identification and classification of avalanche tracks in terms of the history, expected frequency, size, and hazard potential of their avalanches. This information, in turn, can be applied to help solve highway maintenance and public safety problems by allowing for more reliable avalanche prediction and/or control.

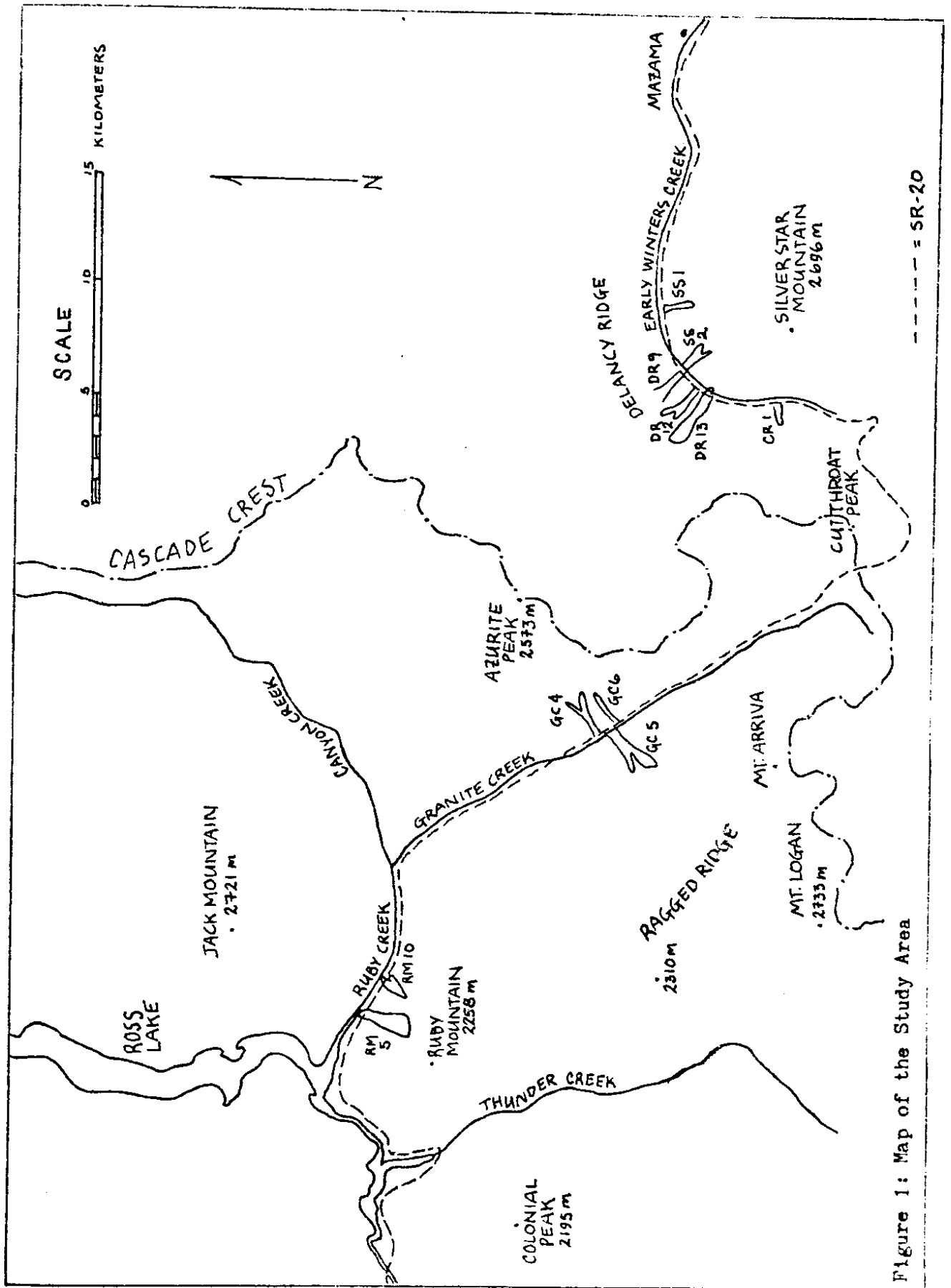

Figure 1: Map of the Study Area

THE STUDY AREA

Geography

The Cascade Range extends from Canada to northern California. The North Cascades are defined by Snoqualmie Pass, Washington on the south and the Canadian-United States border on the north. The study area is located in the North Cascades, just south of the Canadian border. From the Cascade Range crest, the study area borders the North Cascade Highway (SR-20) west to Newhalem and east to Mazama (Figure 1).

Physiography, geology, and soils

Franklin (1965) discusses primary factors responsible for the present rugged topography of the North Cascades. Although much of the present Cascade Range was created by upwarping in late Tertiary time, uplift was strongest in the North Cascades and decreased steadily to the south. Elevations of the higher peaks and ridges in the study area are 2134 m to 2743 m. The North Cascades have, in addition, been exposed to extensive glaciation and still support many active glaciers. High elevation and glaciation account for the overall deeply-dissected topography of the North Cascades, as well as the presence of features such as U-shaped valleys and moraines.

Livingston (1969) states that the northern Cascades are primarily comprised of "granite intrusives, old metamorphosed sedimentary and volcanic rocks (phyllite, marble, greenstone, greenschist, gneiss, etc.) and scattered patches of younger volcanic extrusive rocks". The complexity of the soil pattern in the North Cascades is attributed to the effects of glaciation and a great variability of parent material (Franklin and Dyrness, 1969). On some avalanche tracks and other steep mountain areas where geologic erosion proceeds rapidly, fresh parent material is constantly being exposed and deposited. Profile development is limited on such sites and soils are relatively immature.

Lithosols developed on consolidated rock and Regosols developed on deep, unconsolidated deposits such as glacial drift, are common to areas that have been strongly glaciated such as the North Cascades. The characteristics of these soils are determined primarily by the composition and degree of consolidation of parent material and, to a lesser extent, by vegetation and climate. In general, the most widely distributed great soil groups in the North Cascades are Podzol, Brown Podzolic and Lithosol (Franklin and Dyrness, 1969). Chestnut and Brown soils are abundant east of the Cascade crest reflecting the drier conditions under which they were formed (Franklin and Dyrness, 1973). A comprehensive review of the geology and soils of the North Cascades is given by Douglas (1969 and 1970).

Climate

The Cascade Range, running north-south, is a barrier to maritime and continental air masses. The climate east of the Cascade crest is therefore markedly different from the climate west of the crest. The western slopes of the North Cascades have a moist growing season with little or no summer drought. Precipitation is generally less east of the crest. The eastern slopes have a warmer, drier growing season, and summer droughts are common. During the winter temperatures are lower east of the crest and there are fewer instances of rain. On both sides of the crest, precipitation and snowfall increase and temperatures decrease rapidly with an increase in elevation.

In the study area mean annual precipitation west of the crest is roughly 250+ cm. On the east side the level quickly drops to 160 cm, even at high elevations, and continues to drop steadily to about 80 cm near Winthrop in the Methow Valley (U.S. Weather Bureau, 1960). Although there is some variation, precipitation throughout the Cascade Range is seasonal with less than ten percent occurring from late June to September (Franklin, 1965). Within the Cascades relief as well as elevation strongly influences local climate. The result is a mosaic of different microclimatic conditions within even a small area.

Snow depths in the study area have been recorded at several elevations east of the Cascade crest since the winter of 1971-1972 (Geophysics Program, 1972). The winter of 1971-1972, preceding the field season of this investigation, was severe throughout the Washington Cascades in terms of above average snowfall and avalanche activity. Maximum snow depths recorded that winter in the study area were 409 cm at Washington Pass (elevation 1678 meters), 297 cm at Cutthroat Creek (elevation 1219 meters), and 168 cm at the mouth of Early Winters Canyon about 2 km. west of Mazama (elevation 671 meters). In contrast, the winter of 1972-1973 was quite mild. Maximum snow depth measured at Washington Pass was only 222 cm; almost half that of the preceding winter. This difference in snow depths illustrates somewhat the great climatic variability of the region. Although the data are incomplete, they suggest general trends. The snow depth record showed a systematic increase with increase in elevation as the snowpack began to grow in November. Maximum depths were reached in March, 1972 and in January, 1973 further illustrating the differences in the nature of the winters.

Vegetation

The study area includes two quite different ecological provinces. The Mt. Baker Province west of the Cascade crest and the Wenatchee Province east of the crest were suggested by Franklin (1965). The classification of these geologically similar areas is based primarily on differences in climate and vegetation. The general characteristics of the vegetation in these provinces have been discussed by several investigators (Franklin, 1965; Franklin and Dyrness, 1973; Douglas 1969 and 1970).

Elevations of avalanche starting zones in the study area range from 366 to 2438 meters, and average 1829 meters. The lengths of vertical fall range from 122 to 1646 meters with an average fall of 853 meters. Vegetation study on and adjacent to avalanche tracks was conducted within the closed or continuous forest zones at elevations of 640 to 1417 meters west of the crest

and 1036 to 1676 meters east of the crest. Portions of these forests fell within the following vegetation zones described by Franklin and Dyrness (1973). General trends observed within the study area by Smith are noted. Scientific names and authors of tree and shrub species are listed in Appendix 1. The authority used for vascular plants is Hitchcock and Cronquist (1973).

The mesic, low elevation sites found west of the Cascade crest on the north to northeast facing slopes of Ruby Mountain are in the Tsuga heterophylla Zone. Douglas-fir, a subclimax species on these sites, dominates the forest overstory. Western hemlock, the major climax species, occurs in the overstory, but is more common in the understory where it grows with western redcedar. Less common species are yew, Pacific silver fir, Alaska-cedar, and lodgepole pine. Large shrub species in the understory include Acer circinatum, Acer glabrum var douglasii, Salix spp., Sorbus sitchensis, and Amelanchier alnifolia. In addition to these shrub species, vegetation on sites disturbed by avalanche activity includes Alnus sinuata and Prunus emarginata as well as some coniferous species.

With an increase in elevation, the environment becomes wetter and cooler, and the Abies amabilis Zone replaces the Tsuga heterophylla Zone. Much of the Granite Creek tracks appear to be in this zone. The forest overstory is dominated by Douglas-fir and western hemlock, the major pioneer species. Also present in the overstory, but less abundant, are Engelmann spruce, subalpine fir, and western white pine. Pacific silver fir, the major climax species in this zone, is abundant as seedlings. Alaska-cedar and mountain hemlock are present at the upper extent of this zone. Grand fir and lodgepole pine occur only in relatively small groups or as scattered individuals, and are generally of minor importance. Although Salix spp. and Sorbus sitchensis occur occasionally, large shrubs are not common beneath the tree canopy. Sites disturbed by recurrent avalanche activity support dense shrub communities composed of Alnus sinuata, Acer glabrum var douglasii,

Sorbus sitchensis, Salix spp., Amelanchier alnifolia, and Prunus emarginata. Acer circinatum, found only in association with the Ruby Mountain tracks, is no longer a component of the vegetation.

The upper extent of the closed forest zone west of the Cascade crest lies in the lower subzone of the Tsuga mertensiana Zone. This zone was encountered in the continuous forest at high elevations on east-facing Granite Creek 5. Major species are mountain hemlock, Pacific silver fir, and Alaska-cedar. In addition to being climax species in this zone, these three species are also able to pioneer moist sites. Engelmann spruce and western white pine are less abundant. Lodgepole pine and subalpine fir are able to pioneer dry sites, and were found on exposed, possibly drier sites. Alnus sinuata grows beneath the forest overstory with Menziesia ferruginea, Rhododendron albiflorum, and Cladothamnus pyrolaeiflorus. Alnus sinuata, Salix spp., Sorbus sitchensis, and Rhododendron albiflorum dominate sites exposed to frequent avalanche activity.

Near the Cascade crest Pacific silver fir is the most abundant species, but it decreases in importance with a decrease in elevation east of the crest. Western hemlock, grand fir, and Alaska-cedar were not found in association with any of the tracks east of Washington Pass. On the eastern slopes of the North Cascades, the upper closed forest lies in the Abies lasiocarpa Zone. Subalpine fir and Engelmann spruce become increasingly important components of forest vegetation. These species occur in habitats characterized by drainage and accumulation of cold air (Franklin and Dyrness, 1973), and are able to extend their range to lower elevations in the glaciated valley bottom of Early Winters Creek. At high elevations in this zone mountain hemlock, whitebark pine, and less frequently subalpine larch occur. On drier sites within this zone, Douglas-fir is abundant along with western white pine and lodgepole pine. Subalpine fir is the major climax species within the closed forest portion of this zone. It is occasionally challenged for dominance by Engelmann spruce

and mountain hemlock (Franklin and Dyrness, 1973). Variations of communities typical of this zone are encountered on the steep, high elevation slopes of Cutthroat Ridge and Silver Star Peak. Subalpine fir may pioneer and be maintained as a topodaphic climax on talus slopes and sites subject to recurrent disturbance by avalanches such as found on the path of Cutthroat 1 and in the starting zone of Silver Star 1. Shrub communities similar to those found in lower forested zones may develop on the most moderate sites following disturbance (Franklin and Dyrness, 1973).

Lower elevations of the Delancy Ridge and Silver Star tracks are in the Pseudotsuga menziesii Zone. In the study area this zone is eventually replaced by the Pinus ponderosa Zone at lower elevations and by the Abies lasiocarpa Zone at upper elevations. Environmental conditions created by the shape of the Early Winters Creek valley and the southeast and northwest slope aspects result in ill-defined zone limits as well as distinct vegetation patterns. The southeast slopes of Delancy ridge get quite hot in the summer months, and except where the soil is subirrigated or near streams, moisture may be limiting. Major tree species on these slopes are Douglas-fir and ponderosa pine. Some western white pine and lodgepole pine are present. Subalpine fir and Engelmann spruce occur occasionally on the upper slopes, but become major species in the valley bottom. Populus tremuloides and Ceanothus velutinus occur abundantly on these slopes, but were not found in association with any other track studied.

Across the valley from Delancy Ridge the north to northwest slopes of Silver Star Mountain are, in contrast, cool and moist. Forests are dominated by Douglas-fir and subalpine fir. Western white pine, lodgepole pine, and Engelmann spruce are present, but not abundant. Ponderosa pine is very rare occurring only on exposed, rocky sites. Western redcedar is relatively common, however, both on and off the tracks of Silver Star Mountain. It was not found

in association with any other track studied east of the Cascade crest.

Avalanche tracks are easily identified on the forested slopes of the North Cascades (Figure 2). Even an avalanche of single occurrence leaves a definite trail through the vegetation. An avalanche track which runs through vegetation is defined by trim lines which mark the extent of avalanche influence on the vegetation. Trim lines may fluctuate over time due to variations in the magnitude and frequency of avalanches. Vegetation on avalanche tracks may be damaged or completely destroyed. Angiosperms are often deformed by avalanche activity, and grow with their stems leaning downslope in a declined or decumbent manner (Figure 3). Avalanches may uproot trees and leave large quantities of debris and snow along the track and in the avalanche deposition zone. Large avalanches may extend part way up to the opposite slope from their origin, damaging vegetation and laying trees down in an upslope direction.

Snow Avalanches

Schaerer (1972) working in the area of Rogers Pass, British Columbia, found that the number of times that avalanches occur is determined more by climate (i.e. frequency and magnitude of snowfalls, temperatures that remain close to zero degree Centigrade, and direction and speed of wind) than by terrain characteristics. Conclusions about how much terrain influences avalanche occurrence can only be drawn in conjunction with climatic conditions. Other important parameters relevant to the frequency of avalanches are the slope incline, shape of the avalanche track, ruggedness of terrain, vegetation cover, and exposure to wind and sun.

Fox (1973) has attempted to identify synoptic weather situations or patterns associated with periods of widespread avalanching in the Washington Cascades. He points out that the "nature and relative importance of weather



Figure 2: In the study area an avalanche track running through the undisturbed closed forest is easily recognized. Frequent avalanche activity maintains dense shrub communities on the lower portion of this track, Silver Star 2. The trim lines are well-defined.

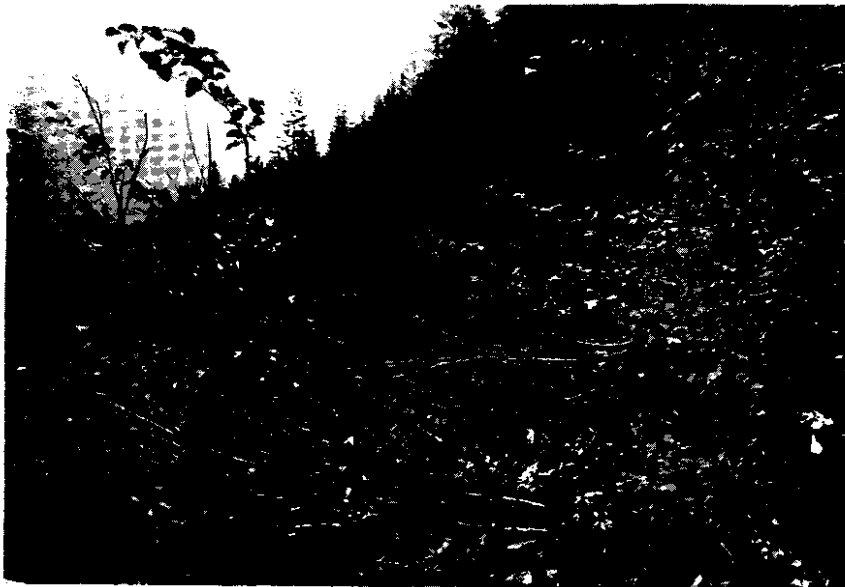

Figure 3: Alnus sinuata growing with stems widely curved downslope is common on many sites exposed to frequent avalanche activity.

factors which are associated with avalanche formation may vary greatly from place to place", even within an area having a generally similar climate. A dominant feature associated with widespread avalanching in this region is a meteorological sequence of substantial snowfall followed by a warming to temperatures near or above freezing. "In each of the case studies, the initial warming was followed by a period of continuing precipitation at temperatures which remained relatively warm, and avalanching continued throughout this period." Fox found that the above sequence was "produced by a variety of synoptic weather situations in the cases studied".

Snow avalanches which occur in the North Cascades have been classified as two types, wet and dry, for the purposes of this study. "A slab or loose snow avalanche is wet if free water can be seen in or squeezed from the debris, or if the debris is obviously refrozen when inspected several hours after the event" (U.S. Forest Service, 1971). Wet snow avalanches move as a dense mass of snow and are generally confined to gullies or streambeds as they follow the contours of terrain. Dry snow avalanches may also be slab or loose, but they do not contain liquid water. They are not as dense nor are they confined to low areas of a track. Rather than flowing down a slope, dry snow avalanches often become partially airborne (powder snow avalanche). Such avalanches generally have much higher velocities, up to 45 to 60 kilometers per hour, than flowing avalanches. The high velocity, 155 kilometers per hour, dust cloud which creates the windblast of large dry snow avalanches is often responsible for large amounts of timber destruction such as is involved in the enlargement of trim lines. Wet snow avalanches are forceful due to their density rather than their velocity.

During the winter of 1971-1972, Fox (1973) noticed a trend "toward a greater percentage of wet slides in the later cycles, as spring approached. When both wet and dry avalanches were occurring, there seemed to be a tendency

for the dry slides to be occurring at higher elevations, and the wet slides at the lower elevations."

Potter (1969) found evidence to suggest that the frequency of avalanches at high elevations in the Absaroka Mountains, Wyoming is much higher than that of avalanches which pass into the forest below. This also appears to be the case on some avalanche tracks in the North Cascades.

Schaerer (1972) found that in order to produce large avalanches, a steeper incline is necessary on open slopes than in channels such as valleys, gullies and troughs. One important reason for the difference is that channels tend to have many small avalanches and the snow deposited by them forms a smooth sliding surface.

From observations made over a twelve year period, it was found that avalanches lose speed on an open snow surface when the incline is less than 28° . They begin to deposit their snow when the talus slopes and alluvial fans of the outrun zones are flatter than this critical angle.

The type, frequency and speed attained by avalanches and the nature of depositions will strongly affect vegetation pattern.

LITERATURE REVIEW

Vegetation of avalanche tracks in Washington

The unique nature of avalanche track vegetation has been mentioned briefly by several investigators in their vegetation studies of selected areas of the Pacific Northwest (Franklin and Trappe, 1963; Franklin and Mitchell, 1967; Franklin and Dyrness, 1969 and 1973; Fonda and Bliss, 1969; Douglas, 1969 and 1970).

Franklin and Trappe (1963) mention avalanche tracks in the area of Mt. Baker, Washington, which are dominated by species of Alnus, Acer, or herbaceous species. Alaska-cedar and less often subalpine fir were components of these tracks.

In the Olympic Mountains, Washington, avalanche tracks were found to be covered with dense stands of Alnus sinuata generally less than 5 meters tall. Alaska-cedar was frequently observed at upper elevations of avalanche tracks, sometimes coming farther downslope in response to cold air drainage (Fonda and Bliss, 1969). These workers mention that "avalanche tracks usually end in valley bottoms and that many times subalpine trees were found growing at the bottom of avalanche tracks. Often this is well into the montane zone where the seeds had presumably been carried by snow."

Franklin and Dyrness (1969) found Alnus sinuata communities to "occupy sites subject to deep winter snow accumulations and extensive snow creep" as well as recurrent snow avalanches. In the Washington Cascades repeated avalanching is, they feel, at least partially responsible for the creation and maintenance of these communities. However, in Oregon, Alnus sinuata communities appear on sites that are not avalanche tracks but do have heavy snow accumulation and abundant seepage water. Alnus sinuata communities are, they feel, "to all appearances a stable community type or are only very slowly encroached upon by forest vegetation". Alaska-cedar is mentioned as the only conifer capable of surviving and reproducing on these sites with recurrent avalanches.

Douglas (1969 and 1970) has studied the vegetation of the North Cascades with emphasis on the Subalpine Zone of the western North Cascades. The avalanche track habitat in this area is common in both the upper continuous forest and the Subalpine Zone. The pioneer communities on slopes which consist mainly of boulders and rocks usually consist of mosses with invasion by vascular plants taking place with accumulation of good soil. Douglas suggests that if the snowslide has resulted in soil being mixed with rocks immediate invasion of Alnus sinuata may take place, especially at lower elevations of this habitat. He is uncertain whether the frequent clumps of Alaska-cedar invade with the Alnus sinuata or at a later time. Subalpine fir or, less frequently, mountain hemlock or Pacific silver fir may be found as climax species where disturbances are sporadic. Succession may be set back, however, on some avalanche tracks due to the high frequency of disturbance.

Subalpine fir is an important pioneer on talus and some avalanche tracks in the northeastern Cascades. It is often maintained as a topopedaphic climax due to the severity of these frequently disturbed sites (Franklin and Mitchell, 1967).

Most of these investigators mention the extreme resiliency of Alnus sinuata and Alaska-cedar stems as a factor contributing to their ability to survive on avalanche tracks and under heavy snowpack.

Vegetation Characteristics as Indicators of Snow Avalanche Characteristics and Periodicity

Gorchakovskii and Shiyatov (1971) discuss methods of inferring snow cover and snow avalanches through the study of the influence of snow on the external appearance and increments of trees and shrubs, and on the times of appearance and disappearance of certain phenophases of shrubs and herbaceous

plants. They found they could determine the following characteristics of various habitats on the basis of botanical criteria: 1) the average and maximum (over several years) thickness of the snow cover, 2) the manner in which snow accumulation conditions vary, 3) the prevailing direction and intensity of snowdrifting, 4) the density of the snow, 5) the time of recession of the snow cover, 6) the locations of areas subject to snow avalanches, and 7) the times and frequencies of recurrence of avalanches. They cite the work of Akif'eva and Turmanina (1970) who were able to draw correlations between the height of willows and birches growing on avalanche tracks and the magnitude and frequency of snow avalanches occurring on those tracks.

Schaerer (1972) studied the height and age of trees in avalanche out-run zones at Rogers Pass, British Columbia. Only those trees that were fully exposed to avalanches and not protected by boulders or features of terrain were selected for study. With the aid of avalanche records kept since 1953, Schaerer was able to suggest general vegetation characteristics useful as indicators of avalanche frequency and magnitude in that area. Although he is aware that numerous parameters determine avalanche size and frequency of occurrence, Schaerer found that an idea of the average frequency of avalanches can be obtained from the average incline of the avalanche track and the species and condition, primarily size, of trees established in the runout zone.

Potter (1969) working in the Northern Absaroka Mountains, Wyoming, used the following criteria to determine the frequency of large snow avalanches that pass below the forest line: 1) datable scars on trees, 2) changes in growth-ring pattern from concentric to eccentric, caused by tilting, 3) changes in growth rate, 4) age of trees within a given reforested avalanche track. He found the first two criteria to be the most reliable. The last two criteria were useful for reinforcement of dates when they were found to correspond with evidence derived using the first two criteria. He points out that sawed sections from trees provide a more reliable record of disturbance than tree increment borings.

MATERIALS AND METHODS

Field Procedure

From the avalanche tracks that cross the North Cascade Highway, eleven representative tracks were selected for vegetation study. From west to east the tracks examined are: Ruby Mountain 5, Ruby Mountain 10, Granite Creek 4, Granite Creek 5, Granite Creek 6, Cutthroat 1, Delancy Ridge 13, Delancy Ridge 12, Delancy Ridge 9, Silver Star 2, and Silver Star 1 (Geophysics Program and Department of Civil Engineering, University of Washington, 1971).

At least two horizontal transects were run across each of the eleven selected avalanche tracks. Transects were run, in almost every case, from vegetation which was judged to be undisturbed by avalanches (i.e. outside the trim line) on one side of the track into the undisturbed vegetation, outside the other trim line, on the opposite side of the track. Each transect was established with a compass along a line intended to minimize elevation change. Temporary plots were established along the transect lines at set intervals; in most cases 30 meters. Distances were measured with a 100 foot fabric tape.

The number of transects run on any given avalanche track, the distance between transects, and the distance between plots on transects varied from track to track depending upon such factors as the size of the track, topographic features and frequency of vegetation change. Transects were run on the lower portions of the tracks and the starting zones ignored in all cases with the exception of Silver Star 1. Starting zones are often relatively inaccessible such as those located on steep rocky slopes of mountain ridges. At the high elevations of most starting zones, woody vegetation, if present, is likely to be patchy. In addition, it could be difficult to determine avalanche history from vegetation growing in an environment severe in other ways such as snow duration, snow creep, and wind. In a preliminary survey of this kind, it was felt that the amount of time required in terms of travel on foot to study the higher elevations would yield a low return. Lower elevations on these tracks, including avalanche

deposition zones, are readily accessible. Because the highway crosses most of the tracks through their runout and snow deposition zones, avalanche activity and periodicity at these lower elevations was of primary interest. In the closed or continuous forest zones, the influences of avalanching snow on vegetation were found to be pronounced.

At each 10 by 10 meter plot, degree of slope was determined with a clinometer, elevation with an altimeter, and slope aspect with a compass. Information about the location such as features of terrain and readily observable soil characteristics was recorded along with the distribution, abundance and dimensions of larger woody species. Trees, shrubs, and other large perennial vegetation were the primary concern in this study. Because these species are woody and live more than one year, they are able to provide more information of an historical nature regarding avalanche activity.

Within each plot, all trees greater than 2.54 cm (1 inch) in diameter and/or taller than 1.54 meters (5 feet) were measured for total height and diameter, usually at 1.37 meters (4.5 feet). Other trees were counted and grouped by species and size. Damage patterns were noted along with other characteristics of the vegetation possibly resulting from avalanching snow. An increment borer was used to determine the age of representative trees. Increment borings, hereafter referred to as tree cores, were removed, placed in plastic straws and identified by path, plot, and the trees' species, diameter, height and age. The height of removal, varying from 0.3 to 3 meters from the root crown depending upon the form of the tree, was noted. This information was also recorded in a field notebook. The tree cores were stored in the straws for further examination.

The use of tree cores to determine tree age requires that certain assumptions be made about a tree's initial growth rate. The number of growth rings in the bole indicate the actual age of a tree only from the ground up to the height attained during the first year of growth.

This may be as close as 2 cm from the root crown in some cases. It is unlikely, therefore, that cores removed 0.3 meters or more from the base of the tree reflect the true age of the tree. For this reason, judgements must be made, considering the environment and the species, as to how old the tree was when it initially reached the height where the core was removed. That number of years must then be added to the age shown by growth rings in the tree core to arrive at the true age of the tree. Evidence from other sources can increase the reliability of such an estimate. In addition, the possibility of false and discontinuous rings, which may not be recognized in a tree core, make a cross section of the tree's main stem taken relatively close to the base of the tree the most reliable source of information regarding the age of the tree.

Because the goals of this preliminary investigation did not require strict adherence to a uniform procedure for gathering data, the exact sampling procedure varied from track to track. Judgement of the investigator was used to determine the procedure followed on any given track. On selected plots, a vegetation profile was drawn along the compass line, and photographs were taken.

Dendrochronological criteria used as indicators of Snow Avalanche

Characteristics and Periodicity

Dendrochronological criteria used in this study as indications of avalanche characteristics and activity include those used by other investigators (Gorchakovskii and Shiyatov, 1971; Potter, 1969; and Schaerer, 1972). The following criteria were used to infer frequency, magnitude, and extent of avalanches on the selected tracks.

1) Time of appearance of reaction wood in trees

When a tree is tilted from its normal vertical orientation its growth

becomes eccentric. Reaction wood is a general term which refers to the specialized type of wood produced on the wide side of eccentric cross sections of stems. In conifers, reaction wood is formed on the lower side of leaning trunks and is called compression wood. In angiosperms, it is formed on the upper side and is called tension wood. Trees can be tilted by a variety of forces including snow creep and avalanching snow. If a tree growing vertically is pushed over by an avalanche, but not killed, reaction wood will appear abruptly in the wood produced the following growing season.

Sawed cross sections from trees are the only reliable source of this information due to the fact the recognition of reaction wood requires a comparison of growth ring widths on all sides of the tree. It may be possible to obtain such information without destroying a tree by removing cores at the same height from opposite sides of the tree parallel to the direction of the slope, or, if the tree is leaning, parallel to the direction of tilt.

2) Datable scars on trees

Because scars can be caused by a variety of factors such as fires and falling rocks in addition to the force of snow and debris carried in avalanches, it is necessary to determine the cause for correct interpretation. The time (year) in which a tree was scarred is also best obtained in a cross section from the tree. However, if the scar is visible externally, a slice of wood may be cut such that it includes the entire scar and the wood produced since scarring occurred.

3) Datable breakage

Avalanches are often responsible for breaking the main stems of trees. On conifers, a lateral branch may begin to grow vertically and become the new leader. In certain situations the number of growth rings in the new leader occurring above the height of the break will give a rough indication of the minimum number of years since the break occurred. In angiosperms that sprout from the root crown when above-ground stems are removed, the age of new stems could also provide such information. In most cases, however, this situation

would be difficult to recognize.

4) Abrupt changes in growth patterns

An abrupt change in growth pattern may reflect a sudden change in a tree's growing conditions. An abrupt and continued increase in growth rate, or release, may be caused by improved growing conditions resulting when adjacent trees, competitors for growth requirements, are destroyed, presumably by avalanching snow. An abrupt decrease in growth rate may be the result of avalanche damage such as severe scarring or removal of foliage. It could also result from the shock of exposure to a more severe environment if adjacent trees which had previously provided protection are removed. Abrupt changes in growth rates may also be reflections of general environmental conditions such as the length of the growing season, moisture availability, or the health of the tree. Interpretation of growth rates must be done carefully and should include comparisons of the tree in question with other trees of the same species growing in similar situations as well as with trees growing on adjacent undisturbed sites. Avalanche activity is a primary variable which may directly or indirectly account for differences in growth patterns between trees growing on avalanche tracks and trees growing outside the trimlines. The physical condition of these trees and their relationships to the trees around them should also be examined. Sawed cross sections are again the most reliable source of growth rate information.

5) Age of debris

The growth ring pattern of a section cut from a dead tree may be fit in with the growth ring pattern of live trees of the same species growing nearby. If such a fit can be made, the additional growth rings in the live tree indicate the number of years that have passed since the other tree was killed. The cause of death, avalanche damage or other cause, can usually be determined.

6) The nature of reforested areas of an avalanche track

Vegetation characteristics such as species composition, community structure, age distribution, and damage patterns can provide information regarding avalanche

characteristics and periodicity. Identification and interpretation of workable criteria of this sort are not independent of the results of the field investigation. They will, therefore, be discussed under results and discussion.

Of these six criteria, the first two are quite reliable methods of dating past major avalanches. The other four criteria are subject to control by a wider range of variables and their interpretation, therefore, often involves a greater number of assumptions. Information should be obtained using all available sources. Evidence from quite different criteria often reinforce each other and indicate certain periods of time when avalanche influence was widespread. Therefore, by comparing information from a variety of sources, uncertainty is reduced somewhat and a fairly reliable record of past disturbance and avalanche periodicity and activity can be obtained.

RESULTS AND DISCUSSION

Interpretation of Vegetation Characteristics and Pattern in Terms of Snow Avalanche Characteristics and Periodicity

Interpretation of vegetation characteristics in reforested areas of avalanche tracks involves consideration of a wide range of factors. By contrasting vegetation on avalanche tracks with adjacent vegetation outside the trimlines in terms of species composition, age, structure, and physical dimensions of individuals, information can be gained regarding avalanche characteristics and periodicity. As previously mentioned, such comparisons illustrate the direct and indirect influences of avalanche activity. Observed vegetation patterns cannot be interpreted without some understanding of the autecology and physical characteristics of the species involved. Plant community characteristics must, in turn, be considered in light of species interactions and the environment. According to the situation, vegetation characteristics may be influenced to varying degrees by a large number of site factors and environmental conditions such as elevation, degree of slope, slope aspect, soil properties, topography, insolation, wind, temperature and moisture regimes, and the direct effects of snow including avalanche activity.

Consideration of all these factors is necessary because vegetation patterns on avalanche tracks are the effects from which the nature of the cause, avalanches, is being inferred.

Avalanches exert a strong selective influence on the vegetation in their paths and, therefore, do not need to occur frequently to have a pronounced effect on the characteristics of plant communities. On a given site, the size and periodicity of avalanches will determine, in part, which species or individuals are favored and which are excluded. Avalanches can exert selective force directly in the form of mechanical damage or indirectly by altering soil conditions or microclimate. As a result of avalanches, then, one species may be given a competitive advantage over another which is strongly selected against. This may occur in a habitat where, in the absence of avalanches, they are able to coexist or the opposite species is excluded.

As is often the case in investigations of this kind, the amount of variation observed in the field seems tremendous, and each situation appears to be quite unique. Nevertheless, an attempt has been made here to suggest general guidelines or criteria by which vegetation on avalanche tracks can be interpreted in terms of avalanche characteristics and frequency in the study area. Any one of the following situations does not necessarily apply to an entire avalanche track. The occurrence and distribution of more than one of these vegetation patterns on a single track is a reflection of the long or short term variation in avalanche activity within that track. Incorporated in the following categories, which include features of species composition, age distribution, and damage patterns, are assumptions about the selective action of avalanches of various sizes and frequencies.

1) Wet to mesic sites, especially at lower elevations, which are severe in terms of avalanche frequency and physical force of snow resulting from avalanche activity are commonly dominated by shrub communities composed primarily of angiosperms. Such sites include gullies and streambeds experiencing frequent wet snow avalanches. In the absence of recurrent disturbance coniferous forests would eventually replace the shrub communities on most sites. Even relatively infrequent avalanche activity may be sufficient, however, to maintain shrub communities. Sites supporting dense shrub communities exist on all tracks studied with the exception of Cutthroat 1, a high elevation talus slope.

2) Drier, commonly high elevation, sites also subject to frequent avalanche activity support conifers rather than angiosperms. Such sites are found on Cutthroat 1, in the starting zone of Silver Star 1, and on ridge sites on several tracks. The dominance of conifers on such sites, which is the rule at the elevations studied, is presumably due to environmental conditions other than avalanche activity. Avalanches do, however, influence the species composition, age structure, and physical condition of vegetation on these sites (Figure 4).

3) Sites which experience avalanche activity on a relatively frequent basis (roughly 10 to 20 year intervals), but where avalanches do not run clear to the ground, either due to features of terrain or avalanche characteristics, are often occupied by coniferous tree species of a variety of ages, but fairly equal height. Conifers growing on these sites are repeatedly trimmed by avalanche activity, usually 0.9 to 4.6 meters from the ground. Because they are only able to grow above the level of trimming in the relatively short periods of time when avalanche influence is slight or absent, avalanche damage usually consists of breakage or trimming of leaders and branches with small diameters. On such sites conifers may survive to be quite old if they are able to maintain functional foliage below the level of trimming. Younger trees are able to establish on these sites due to the protective influence of terrain or basal snow

depths. These sites are common on exposed, often rocky, areas where, as in the above case, environmental conditions, possibly moisture availability or temperature extremes, appear to prevent the establishment and survival of larger angiosperms. Such sites are found on the upper slope ridge sites of Delancy Ridge where trimmed conifers dominate in the absence of arborescent angiosperms.

4) On sites where large avalanches occur infrequently (roughly 20-80 year intervals), but as in the above case, vegetation at least 1 meter from the ground is protected by basal snow depths or features of terrain, infrequent damage patterns, such as breakage of large leaders, are common. On such sites trees are protected when they are small. In the relatively long period of time between large avalanches, vegetation, often consisting of conifers, continues to grow. Shrubs, if present, may be overtopped as succession advances. When a large avalanche does occur, then, trees which have not been continually trimmed and maintained may have grown beyond a critical size. This critical size, below which the tree would be able to survive a large avalanche or escape severe damage, is usually a factor of stem diameter and crown characteristics. It varies between species, often being determined by such characteristics as tree form and inherent flexibility. In any case, the infrequent large avalanche will cause severe damage in the form of breakage and/or damage to foliage of individuals which have exceeded critical size. Those trees which survive such damage continue to grow until the next large avalanche occurs. These sites are most common near the trim lines of some avalanche tracks where the vegetation is only influenced by infrequent, large dry snow avalanches (Figure 5).

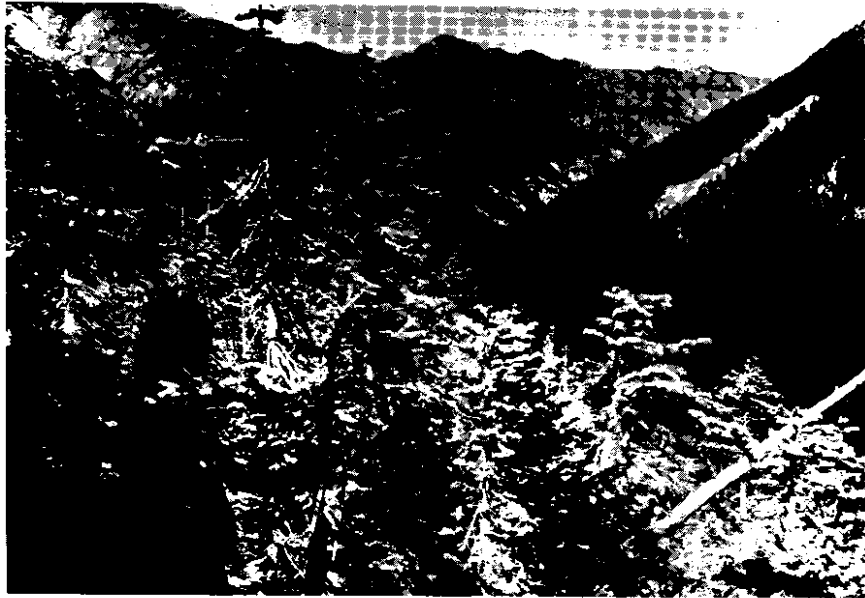

Figure 4: Below 1463 meters elevation, Cutthroat 1 is a talus slope which supports a dense stand of conifers, primarily subalpine fir. Frequent avalanche activity maintains these trees at heights generally less than 4.5 meters.



Figure 5: On sites infrequently exposed to avalanche activity, vegetation is able to grow during the interim and may exceed critical size. When the infrequent large avalanche occurs (at roughly 20-80 year intervals) these trees may be severely damaged or killed. This appears to have been the case with the north face of Cutthroat Ridge in the background. Trees smaller than critical size have suffered little or no damage.

5) On sites very infrequently affected by avalanches much larger than those which usually occur, large trees may be removed, destroyed, or severely damaged. Such trees may have been undisturbed by avalanches their entire lives, possibly 80 to 100+years. In some cases, due to the characteristics of the avalanche (it is airborne or there is a protective basal snow depth) small, flexible, and probably young trees growing in the understory beneath the destroyed trees will survive. The site may not be disturbed again for another 50 to 100 years. During this time, the surviving trees, previously in the understory, will grow up to dominate the site. The resulting forest will have a relatively even-aged overstory, probably composed of tolerant seral or climax species. Residual pioneers, if present, will be rare. The stand structure, in terms of age and species, of the resulting forested area will in most cases contrast strongly with that of the adjacent undisturbed forest. Large debris of the destroyed trees may remain in the disturbed area for many years. Growth rings from these destroyed trees can be fit in with the ring pattern of older, living trees outside the trim lines to determine when the avalanche occurred. Because the surviving trees were established prior to the occurrence of the avalanche, their ages will be more than the number of years since disturbance. Increment borings taken from these trees may, however, show abrupt changes in growth rates corresponding to the removal of the overstory. This is a pattern common to areas where a long-established trim line (80-100 years) has been enlarged. It is possible that the overstory will only be thinned on sites at the farthest extent of such avalanches. The site may then be shared by trees predominantly in two age groups. Trim line dynamics on Granite Creek 4 and Granite Creek 6 illustrate these vegetation patterns.

6) On sites completely denuded of forest vegetation by an infrequent extremely large avalanche, regeneration time and species composition of invading vegetation will depend on a variety of site characteristics following the avalanche.

a) Where a suitable seedbed remains, regeneration may occur on the site at the earliest occurrence of conditions favoring seed germination and seedling establishment. Which species invade the site will be determined by the available seed source as well as by factors such as the length of the growing season as affected by snow deposition, microclimate, the nature of the substrate, soil characteristics, and moisture conditions. If there is no subsequent disturbance of the site, the resulting vegetation will be dominated by an even-aged stand of trees able to pioneer the site as modified by disturbance. The age of this stand will roughly reflect the number of years since the last major avalanche occurred on that site. The extent of such an even-aged stand can suggest whether it became established following disturbance by an avalanche or by some other factor such as a fire. Inferring the time lapsed since disturbance requires that assumptions be made about time of establishment and rate of succession of vegetation. This pattern, the existence of an even-aged stand established after a major avalanche, exists in several cases of trim line enlargement such as on Cutthroat 1 and Silver Star 2. On sites initially invaded by angiosperms, conifers will invade and dominate the site given sufficient time with no further disturbance. This is occurring on Silver Star 1 in the bottom of the avalanche runout zone. Again, a comparison with undisturbed vegetation aids in interpreting a vegetation pattern such as this.

b) On some sites the presence of great quantities of timber debris and snow may prevent vegetation establishment immediately following an unusually large avalanche. Variation in the nature and time of appearance of suitable seedbeds can cause variation in the ages and species composition of invading vegetation. This may occur on Granite Creek 5 where debris and snow from a recent large avalanche were piled up to six meters deep on some areas of the track.

Again, the ages of vegetation invading such sites will be less than the number of years since the avalanche occurred.

Summary of Case Studies

Botanical and dendrochronological criteria have been interpreted in terms of avalanche activity and characteristics on the eleven selected avalanche tracks. Suggested explanations for observed vegetation patterns as well as case history and periodicity of avalanches and other major disturbances are based on data obtained June through September 1972. Time, including years of disturbance and ages of vegetation, is in relation to the 1972 field season.

Ruby Mountain 5

It appears that this slope of Ruby Mountain was burned by a fire about 110 years ago. A major large avalanche, probably dry snow, occurred about 70 years ago and partially enlarged the trim lines. Evidence from dating scars and appearance of reaction wood suggests that a relatively large avalanche occurred next about 36 years ago. Although this was probably not as large as the previous major avalanche, it caused considerable damage, primarily in the form of breakage, to trees in the sixty to seventy year age class. Another relatively large avalanche occurred in the spring of 1971. This one was also somewhat smaller than that which occurred roughly 70 years earlier. Avalanches large enough to cause timber destruction have occurred, then, at roughly thirty-five year intervals. The presence of shrub communities suggest that smaller avalanches, probably wet snow for the most part, occur more often. Avalanching may be more frequent at higher elevations on the track (Geophysics Program and Department of Civil Engineering, University of Washington, 1971).

Ruby Mountain 10

The even-aged forest composed of pioneer species found outside the trim lines of this track reinforce the probability of a fire on Ruby Mountain about 110 years ago. Avalanches large enough to cause widespread damage to vegetation seem to have occurred 40 years ago and 20 years ago. The avalanche which occurred 40 years ago was the larger of the two. A relatively small amount

of recent damage was observed in the summer of 1972. The periodicity of quite large avalanches may be considerably greater than 20 years. Avalanche frequency and severity appear to be less on the ridge sites, where species diversity of angiosperms and conifers is high (in terms of richness), than in the streambeds and gullies. These lower sites are dominated by species of angiosperms, and are exposed to avalanches, usually wet snow, as often as annually.

Granite Creek 4

Interpretation of trim line dynamics, particularly species composition and age structure, suggest that major avalanches occur infrequently or sporadically. Avalanches causing extensive damage or trim line enlargement seem to have occurred approximately 130 and 110 years ago as well as in the winter preceding this study. Avalanches somewhat smaller than these, but still responsible for damaging vegetation, appear to have a periodicity of anywhere from 20 to 35 years. Avalanches which occur most frequently, possibly on an annual basis, are relatively small, confined to the center of the track, and cause minimal vegetation damage (Figure 8).

Granite Creek 5

The history of this track can be traced back only as far as a major disturbance, apparently fire, which occurred about 85 years ago. A large avalanche may have occurred soon after the slope was denuded. Since that time, 75 to 85 years ago, frequent avalanche activity has been confined to those areas of the track clearly defined by a dense cover of angiosperms, primarily Alnus sinuata. Avalanches larger than usual seem to have occurred 75, 34, and 20 years ago as well as in January, 1972. This most recent avalanche was the largest of these, and was responsible for extensive timber destruction and trim line enlargement. The largest avalanches on this track have had a periodicity of 35 to 40 years. Avalanche activity may be greater at high elevations on this track.

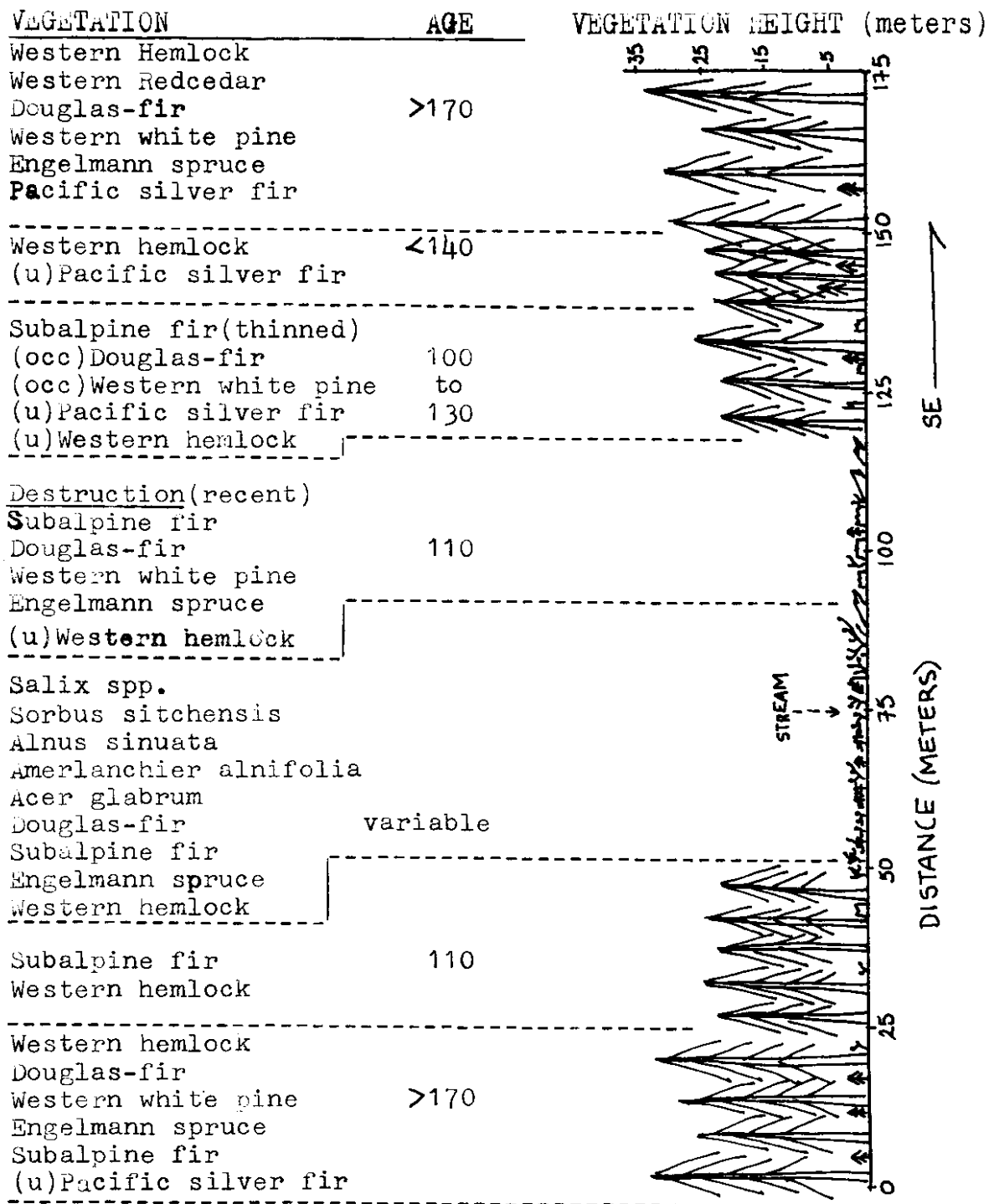

Figure 8: Vegetation profile of Granite Creek 4 (elevation 1073 meters). Ages refer to the overstory. (1972)
(u)=understory
(occ)=occurs occasionally

Granite Creek 6

Avalanches larger than those which occur as often as annually, seem to have a periodicity of approximately 15 to 20 years. The largest of these, probably large dry snow avalanches, have occurred less frequently, about 60 and 34 years ago. Although the extent and paths of these avalanches appear to have differed slightly, all three fingers of the runout zone were probably used by the two largest avalanches. The main southeast finger, presently supporting species of angiosperms, seems to be used by all avalanches, large and small, that reach the level of the highway (Figures 9 and 10).

Cutthroat 1

There is evidence several places on the track for the occurrence of a major avalanche roughly 120 years ago. Large, but less extensive avalanches appear to have occurred 60 to 70 years ago and 35 to 40 years ago. Abrupt changes in growth patterns which do not correspond to the establishment of widespread age classes also occurred 90, 50, and 20 years ago. A general picture emerges, then, of fairly large avalanches occurring roughly every 40 to 50 years with somewhat smaller, less extensive, avalanches occurring in between. Still smaller avalanches may occur as often as several times annually (Figure 11).

Delancy Ridge 13

Evidence suggest the occurrence of a major avalanche about 70 years ago. A large but somewhat smaller avalanche may have occurred 30 to 40 years ago. A large dry snow avalanche fell in January 1971, but major snow deposition occurred above the highway. Fairly large avalanches may have a periodicity, then, of roughly 35 years. Smaller avalanches occur relatively frequently.

Figure 9: Vegetation profile of Granite Creek 6: 1972 (elevation 1061 meters). Ages refer to the overstory. (u)=understory. (occ)= occurs occasionally

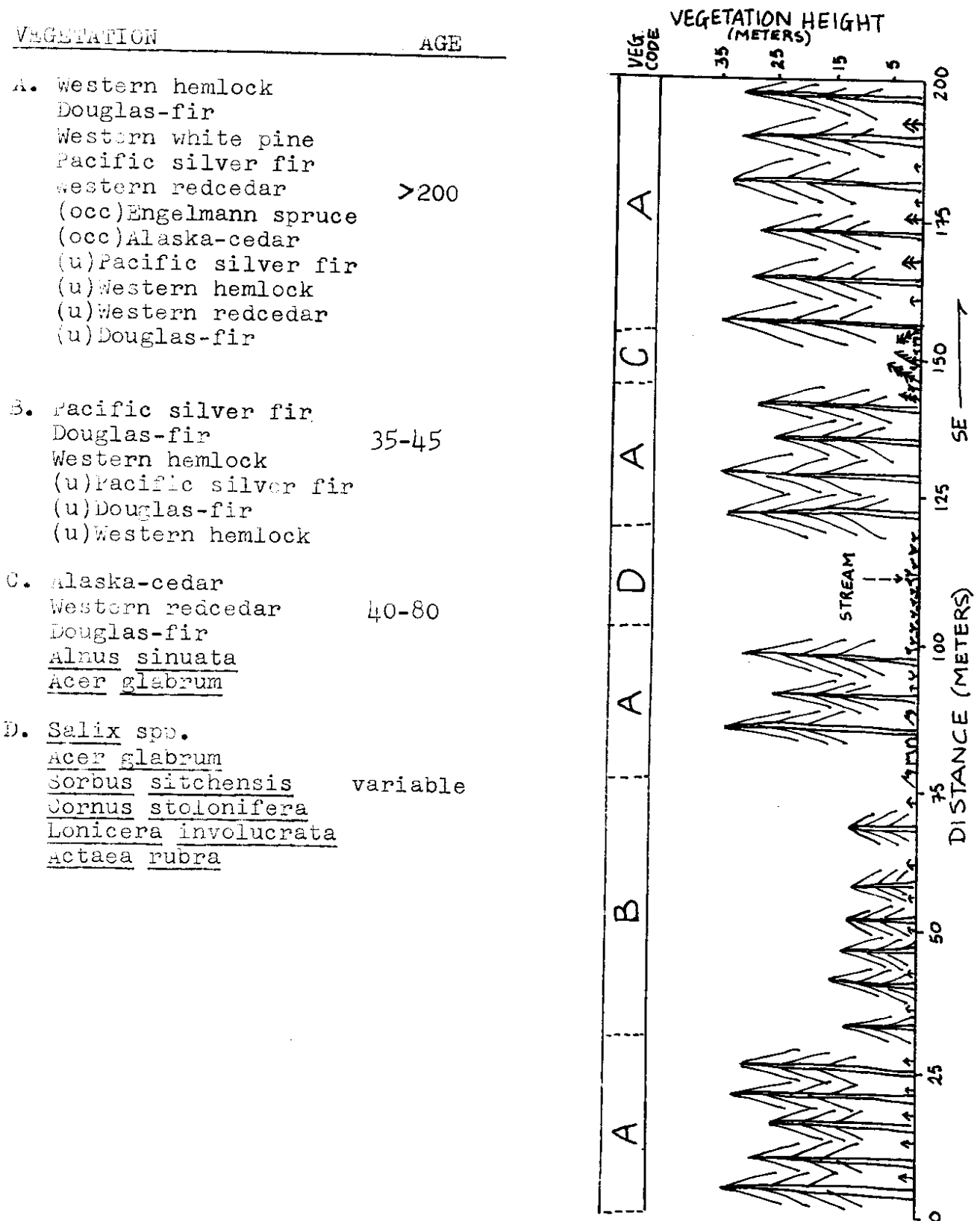

Figure 10: Cores removed from trees in the northwest finger of Granite Creek 6 below the highway indicate release 33 years ago after the stand was thinned by a large avalanche. Younger trees which survived now occupy most of the site.

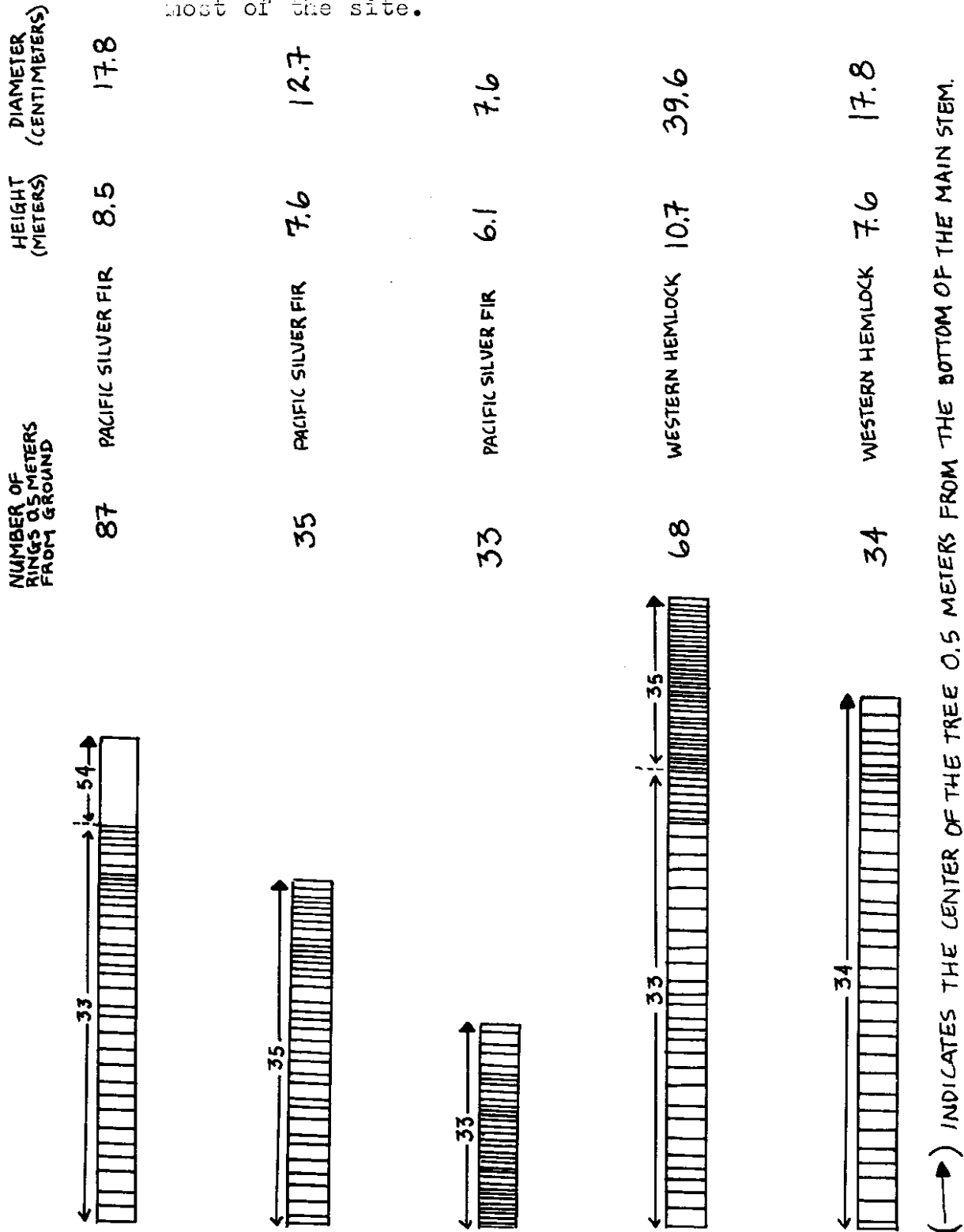
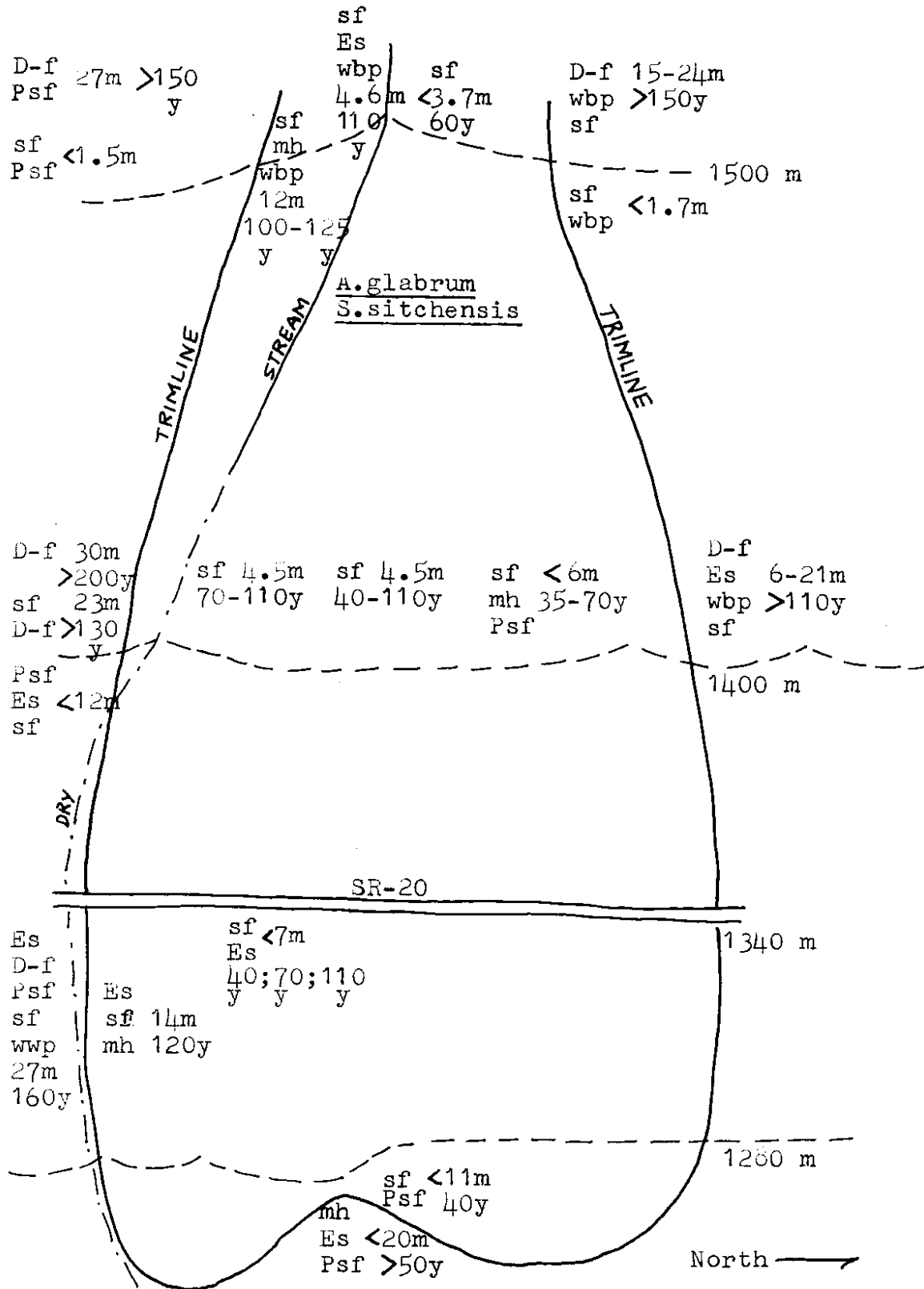

Figure 11: Cutthroat 1: species, height and age distribution.



Key: Douglas-fir(D-f);Subalpine fir(sf);Pacific silver fir(Psf); Whitebark pine(wbp);Western white pine(wwp);Engelmann spruce(Es);Mountain hemlock(mh). Ages in 1972. Heights in meters.

Delancy Ridge 12

The streambed and avalanche deposition zone are dominated by angiosperms including Alnus sinuata, Salix spp., Prunus emarginata, and Populus tremuloides. These areas experience frequent, possibly annual, avalanche activity. Other areas of the track such as the ridge sites where the vegetation is dominated by coniferous trees are subject to severe avalanche force less frequently. Large avalanches have had a periodicity of about 30 years. Evidence suggests the occurrence of large avalanches 60 and 30 years ago as well as in the winter of 1970-1971. This most recent large dry snow avalanche killed many conifers either by trimming off all foliage or by knocking entire trees over.

Delancy Ridge 9

The overall absence of extensive damage and debris on this track and near its trim lines suggests that vegetation has been well maintained from year to year by frequent and fairly uniform avalanche conditions. The vegetation, from the large trimmed conifers to the flexible, curved-stemmed angiosperms, appears to be in equilibrium with the avalanches which generally occur on this path. Significant damage to timber and production of large amounts of debris would result only from an avalanche of sufficient magnitude to enlarge the trim lines once again and/or remove those conifers growing on the track. It appears that such an avalanche, probably dry snow, last occurred about 45 years ago.

Silver Star 2

Vegetation on this path appears to be maintained on a regular basis by frequent avalanches. Somewhat larger avalanches than usual may have occurred approximately 90 years ago, causing limited trim line enlargement, and 60 years ago. Intermittent avalanches, such as that which occurred recently

(1970-1971) as well as that which occurred possibly 30 years ago, are responsible for vegetation damage, primarily to conifers at upper elevations, on the track itself, and have not enlarged the trim lines.

Silver Star 1

It appears that avalanches have occurred on this track more than once in the past, but at low frequency. A large avalanche may have occurred on this track 65 to 80 years ago. This may have been the last time the fingers of the track, particularly the upper finger, experienced avalanche activity of any severity. There is evidence to suggest avalanche activity about 20 years ago. This was less extensive and seems to have caused damage to some conifers, and a general thinning of the vegetation on the main track. Coniferous trees in the starting zone have had regular, but extremely slow, growth. In 1972, quite a bit of recent damage to conifers growing on the main track was observed. Angiosperms on the track and seedlings in the lower elevations of the track were not damaged, however. Although avalanche activity has been infrequent on this track, it has been sufficient to maintain the dominance of angiosperms, primarily at lower elevations. Where conifers and angiosperms grow together on the track, angiosperms are generally considerably taller than the conifers. If avalanche activity in subsequent years is slight, however, succession may advance as coniferous trees are allowed to overtop the angiosperms.

Table 1: Summary of Disturbance History and Avalanche Periodicity

Unless otherwise indicated, times correspond to disturbances caused by avalanches considerably larger than usual. Except for recent avalanches when the actual dates are known, approximate times of disturbance are given in years prior to the 1972 field season.

Ruby Mountain 5	110 fire	60-70	36	1971 Spring	+ freq. high elev. w more common
Ruby Mountain 10	110 fire	40	20		+ w annual d infreq.
Granite Creek 4	130	110		1971-1972	+ w annual * 20-35 years
Granite Creek 5	85 fire	75		1972 January	+ frequent large d infrequent
Granite Creek 6	130	70	34		+ w annual large dry infreq. * 56 & 20 yrs. ago
Cutthroat 1	120	60-70	35-40		+ w and d annual * 30-40 years (70, 50, & 20 yrs. ago)
Delancy Ridge 13		50-70	30-40		+ w and d annual
Delancy Ridge 12	50-70	30		1970-1971	+ w and d annual
Delancy Ridge 9			45		+ w and d annual
Silver Star 2		70-90	60		+ frequent/ d com- mon with major storms * 30 years
Silver Star 1		65-85	20		+ very infrequent

* periodicity of avalanches; somewhat larger or more destructive than usual

+ periodicity of commonly occurring avalanches

w wet snow avalanches

d dry snow avalanches

Succession and Disturbance

If soil is completely removed by an avalanche and only bare rock remains, primary succession occurs usually with the invasion of the site by such plants as lichens and mosses. Primary succession begins on relatively unweathered parent material which has not previously borne a plant cover. Succession advances as established species alter the environment in a way which allows other species to reproduce more successfully than themselves.

Secondary succession appears to be more common on avalanche tracks running through the closed forest. When disturbance results in the destruction of preexisting vegetation but not in the complete removal of soil, secondary succession occurs in which seral communities benefit from soil previously occupied by plants (Daubenmire, 1968). Within the closed forest zones of the study area dense shrub communities appear to be a prominent feature of preforest succession on wet to mesic sites and along drainages. Depending upon environmental factors and the autecology of available species, shrub species may invade disturbed sites with or without coniferous tree species. Plant succession often advances as a consequence of changes in the seedling environment such as in soil properties and in light and moisture regimes. When shrub and tree species invade a site together, succession may depend more upon early species interaction and the longevity of the principal plants involved. In the absence of disturbance shrub communities are seral on most sites. Generally the tree canopy increases as succession advances, and seral shrubs decrease.

In Washington, investigators have most often studied secondary succession following logging or burning or both. The situation is somewhat different, however, on avalanche tracks where disturbances may recur as often as several times annually. Succession is retarded by repeated disturbance, and seral plant

communities composed of shrubs or coniferous trees or a combination of the two may be maintained. The composition of plant communities on avalanche tracks is determined by the characteristics and frequency of disturbance as well as by the available seed source and environmental conditions.

Shrub communities dominated by or including arborescent angiosperms such as Alnus sinuata, Acer circinatum, Acer glabrum, Salix spp., Prunus emarginata, and Amelanchier alnifolia are common on avalanche tracks within the study area, particularly on wet to mesic sites and along drainages. Repeated disturbance by avalanches may favor shrub species and maintain shrub-dominated communities in several ways. A major effect of avalanche disturbance is alteration of the tree canopy. Plants are continually trimmed by the force of avalanching snow. Although neither tall shrub nor coniferous tree species are able to realize their potential height growth under such conditions, the shrub species are generally able to more closely approach their potential height growth, as well as achieve and maintain greater height growth than tree species growing with them. The tree species are therefore deprived of their potential competitive advantage of greater height growth and crown closure.

The following characteristics of arborescent angiosperms may contribute to their success under conditions of recurrent disturbance by avalanches:

- 1) Some species are able to grow beneath a forest canopy, and are therefore ready to immediately take over the site following destruction of the overstory.
- 2) Individual plants of these species are capable of growing with multiple stems. If avalanching snow destroys some stems, others may still survive.
- 3) The roots are often able to survive longer than any single above ground stem.
- 4) Species including Alnus sinuata, Acer circinatum, Acer glabrum, Amelanchier alnifolia, Salix spp., Prunus emarginata, and Populus tremuloides are able to sprout from their root crowns if above ground parts are destroyed.

5) Avalanches are less likely to damage the photosynthetic surfaces and impair the photosynthetic efficiency of these deciduous species which are absent of foliage during the avalanche season. 6) These species, some of which have a potential height growth of up to 12 meters, generally have rapid initial height growth and are able to quickly dominate a site. Because these shrubs usually achieve maximum dominance twenty to thirty years following a disturbance, they are favored and shrub communities are maintained by relatively frequent avalanche disturbance. 7) Physical dimension and growth form are important in determining the reaction of a plant to the force of avalanching snow. These shrub species are able to survive and attain greater height growth than coniferous tree species by offering less resistance to avalanching snow. a) As previously mentioned, these species are deciduous and therefore have only bare stems rather than full crowns during the avalanche season. b) These species generally grow with multiple stems which are slender and flexible in contrast with the single rigid bole of most coniferous trees. c) As a result of avalanche activity these species often grow with curved or bowed stems which, being slender and flexible, are able to bend or lie down rather than break under the weight or force of avalanching snow.

On some well-drained, relatively dry sites such as some talus slope and ridge sites and some high elevation areas, arborescent angiosperms are never able to successfully invade and shrub communities are not part of the successional sequence even under normal conditions. Coniferous tree species, on the other hand, may be able to invade such sites following disturbance. In many cases, they are able to survive in spite of or due to recurrent disturbance by snow avalanches. In the discussion of case studies the following such situations have been described, and explanations have been suggested: 1) the well-established subalpine fir community on the talus covered, high elevation avalanche track of Cutthroat 1, 2) the continually trimmed conifers on the

ridge sites of the Delancy Ridge avalanche tracks, and 3) the forested start zone of Silver Star 1.

Because there are so many variables, which may differ greatly within a short distance, patterns of succession and species interaction are fairly complex. The degree and frequency of disturbance by avalanches may vary in a small area due to characteristics of terrain. Small and large-scale vegetation pattern is also influenced by the distribution and duration of snow. Variation is bound to be pronounced on avalanche tracks where avalanches cause large-scale redistribution of snow. For example, great quantities of snow may be deposited at the bottom of an avalanche track where it could remain for months longer than snow on adjacent sites at the same elevation. In extreme cases, the snow may not melt for several years. In addition to the mechanical effects of massive movement and deposition of snow, snow affects vegetation through its influence on soil moisture and temperature and the length of the growing season.

The amount of water in the soil may also vary within a short distance from permanently saturated to dry and quite freely drained. A saturated soil may be located in a depression where moisture can accumulate while a dry and well-drained soil may be found on an adjacent, slightly elevated, ridge site. Usually in such a short distance there is virtually no difference between the amount of total precipitation. Contrasting plant communities and different soils may develop as a result of the differences in moisture regimes. As previously mentioned, the mosaic of microclimates also contributes to differences in plant communities within a small area.

Environmental factors such as those mentioned above, which control the species composition and successional trends of plant communities, can vary

significantly within a single avalanche track. With a knowledge of environmental conditions as well as a knowledge of the requirements and characteristics of the plant species involved, the successional sequence on a given site may be predicted. This, in turn, will allow for interpretation of plant community characteristics in terms of disturbance and snow avalanche periodicity.

Fire

When starting zones are high above tree line, forest cover generally exerts little or no influence on avalanche formation. On forested slopes, however, protecting snow from the sun and providing anchorage are primary influences of the forest in preventing avalanches (Kittredge, 1948). In such cases, forest removal may strongly affect the degree of avalanche activity on a slope. Although forests can be removed or defoliated by a variety of natural factors, such as wind, insects, and disease, the most common natural cause of widespread forest destruction in the North Cascades, excluding glaciation, has probably been fire.

Munger (1911) studied avalanche activity in the northeastern Cascades, Wenatchee National Forest. Fires occurring between 1885 and 1910 had repeatedly burned a hillside which had previously been well-covered with mature timber. In the winter of 1910, which was severe throughout the Cascades in terms of avalanche activity, many avalanches descended the deforested hillside, presumably for the first time, and at least, for the first time in recent years. The new avalanche activity was attributed to the removal of the protective forest cover.

Munger found avalanches in the North Cascades to be more numerous on deforested slopes than on forested ones. However, he points out that once an avalanche has started, the forest has considerably less effect on its severity. "The chief influence which forests exert on avalanches is at their place of origin, and not after they have gained headway".

In the study area it is possible therefore that fire may have played a role in the formation of tracks, such as Silver Star 1 and Ruby Mountain 10, where the starting zone is located in the closed forest zone. If initial avalanche activity is followed by relatively frequent subsequent activity, early successional communities will be maintained. If there is no subsequent avalanche activity, or it is very infrequent, reforestation will eventually occur as succession advances.

Fire may also, under certain conditions, play a role by eliminating large quantities of timber debris, such as that left by the January 1972 avalanche on Granite Creek 5, and preparing a seedbed for coniferous reproduction. Evidence of past fires was found on several tracks. Fire may have a variety of influences on avalanche tracks and their vegetation in areas such as the North Cascades, but a more specific investigation is required to determine what they might be.

In any case, a concerted effort should be made to carefully protect the forests of the North Cascades in areas of increasing human use during winter months. The removal of these forests could lead to an increase in avalanche sites and activity thereby compounding the problem which already exists.

SUMMARY AND CONCLUSIONS

A general description of the characteristics and species composition of vegetation, primarily tree and large shrub species, on and adjacent to eleven avalanche tracks is given. Physical and ecological explanations of observed vegetation patterns are suggested. Descriptions are given of several common vegetation patterns which appear to be useful as indicators of avalanche characteristics and frequency. Botanical and dendrochronological criteria are presented which were used to infer avalanche periodicity and patterns as well as time of occurrence and extent of past major avalanches.

Although many physical and environmental characteristics of the eleven tracks differ considerably, some generalizations can be made about avalanche activity and vegetation.

1) Available seed source and environmental factors initially determine which plants will establish on avalanche tracks. On a given site, the size, periodicity, and other characteristics of avalanches will determine, in part, which species or individuals are favored and which are selected against. Avalanche activity influences vegetation characteristics such as species composition community structure, and age distribution.

a) Frequent and recurrent avalanche activity may retard plant succession. Species and communities which are seral in the absence of avalanche activity are maintained by frequent disturbance.

b) Reforestation can occur on sites disturbed by avalanches only if subsequent disturbance does not occur for a sufficient length of time. This interval must be long enough (at least 30 years when seral shrub communities are involved) to allow succession to advance to the forest stage.

2) The occurrence and distribution of more than one vegetation pattern on an avalanche track is an indication of the long and short-term variation in avalanches (size, type, and frequency) on that track.

3) Avalanches do not always run the full extent of their tracks, and in several cases avalanches appear to occur more frequently at high elevations on a track.

4) Recent records and approximate dates of past major avalanches show that, in the study area, major destructive avalanches do not necessarily occur on many tracks in the same year. In the North Cascades the winter of 1971-1972 produced major avalanches and extensive damage on some tracks and little or

none on others. Potter (1969) also found this to be the case in the Absaroka Mountains, Wyoming.

A major difficulty in interpreting vegetation characteristics on avalanche tracks is avalanche activity itself. In trying to reconstruct the history of disturbance on a particular track, evidence such as the succession of past trim lines found on Cutthroat 1 are helpful. In many cases, however, evidence of past disturbance may have been confused or lost due to subsequent large avalanches. In part due to this factor as well as the occurrence of other natural disturbances such as fire, the amount of time in which avalanche disturbance can be traced by the means employed in this investigation is relatively short. Long-term avalanche periodicity may therefore be difficult to determine.

REFERENCES

- Daubenmire, R. 1968. Plant Communities: A Textbook of Plant Synecology. Harper and Row, New York. 300 pp.
- Douglas, G. W. 1969. A preliminary biological survey of the North Cascades National Park and the Ross Lake and Lake Chelan National Recreation Areas. A report to the National Park Service. Photocopy. 195 pp.
- _____. 1970. A vegetation study in the subalpine zone of the western North Cascades, Washington. M.S. thesis. Univ. of Washington. Seattle, WA. 293 pp.
- Fonda, R. W., and L. C. Bliss. 1969. Forest vegetation of the montane and subalpine zones, Olympic Mountains, Washington. *Ecol. Monogr.* 39:271-301.
- Fox, T. 1973. Avalanches and synoptic weather situations in the Washington Cascades in the 1971-1972 winter. M.S. thesis. Univ. of Washington. Seattle, WA. pp.
- Franklin, J. F. 1965. Tentative ecological provinces within the true fir-hemlock forest areas of the Pacific Northwest. U.S. Forest Serv. Res. Paper PNW-22. 31 pp.
- _____. and C. T. Dyrness. 1969. Vegetation of Oregon and Washington. U.S. Forest Serv. Res. Paper PNW-80. 216 pp.
- _____. and C. T. Dyrness. 1973. Natural vegetation of Oregon and Washington. U.S. Forest Serv. **General Technical Report** PNW-8. 417 pp.
- _____. and R. G. Mitchell. 1967. Successional status of subalpine fir in the Cascade Range. U.S. Forest Serv. Res. Paper PNW-46. 16 pp.
- _____. and J. M. Trappe. 1963. Plant communities of the northern Cascade Range; a reconnaissance. *Northwest Sci.* 37(4):163-164.
- Geophysics Program and Department of Civil Engineering, Univ. of Washington. 1971. North Cascades Highway SR-20 avalanche atlas. Univ. of Washington. Seattle, WA. 175 pp.
- _____. 1972. Methods of avalanche control on Washington mountain highways. Second annual report. Univ. of Washington. Seattle, WA. 81 pp.
- Gorchakovskii, P. L., and S. G. Shiyatov. 1971. Phytoindication of snow cover and snow avalanches in the high mountains. *Ekologiya* (translated). 1:22-35.
- Hitchcock, C. J., and A. Cronquist. 1973. Flora of the Pacific Northwest. University of Washington Press, Seattle. 730 pp.

- Kittredge, J. 1948. Forest Influence. McGraw Hill Book Company, Inc., New York. 374 pp.
- Livingston, V. E. Jr. 1969. Geologic history and rocks and minerals of Washington. Washington Dept. of Natural Resources, Division of Mines and Geology Information Circular No. 45. 42 pp.
- Munger, T. T. 1911. Avalanches and forest cover in the Northern Cascades. U.S.D.A. Forest Serv. Circular 173. 12 pp.
- Potter, N. Jr. 1969. Tree-ring dating of snow avalanche tracks and the geomorphic activity of avalanches, Northern Absaroka Mountains, Wyoming. Geological Society of America, Inc. Special Paper 123. pp. 141-165.
- Schaerer, P. A. Terrain and vegetation of snow avalanche sites at Rogers Pass, British Columbia. In Mountain geomorphology. B.C. Geographical Series 14:215-222
- U.S. Department of Agriculture. 1965. Silvics of Forest Trees of the United States. Agricultural Handbook 271. Government Printing Office, Washington, D. C. 762 pp.
- U.S. Forest Service. 1971. Avalanche control and occurrence chart.

LIST OF TREE AND SHRUB SPECIES

The authority for scientific names is Hitchcock et al. (1973).

Gymnosperms (Conifers)

<p><i>Abies amabilis</i> (Dougl.)Forbes <i>Abies grandis</i> (Dougl.)Forbes <i>Abies lasiocarpa</i> (Hook.)Nutt. <i>Chamaecyparis nootkatensis</i> (D. Don)Spach <i>Larix lyallii</i> <i>Picea engelmannii</i> Parry <i>Pinus albicaulis</i> Engelm. <i>Pinus contorta</i> Dougl. <i>Pinus monticola</i> Dougl. <i>Pinus ponderosa</i> Dougl. <i>Psuedotsuga menziesii</i> (Mirb.)Franco <i>Taxus brevifolia</i> Nutt. <i>Thuja plicata</i> Donn. <i>Tsuga heterophylla</i> (Raf.)Sarg. <i>Tsuga mertensiana</i> (Bong.)Carr.</p>	<p>Pacific silver fir Grand fir Subalpine fir Alaska-cedar Subalpine larch Engelmann spruce Whitebark pine Lodgepole pine Western white pine Ponderosa pine Douglas-fir Pacific yew Western redcedar Western hemlock Mountain hemlock</p>
--	--

Angiosperms

<p><i>Acer cirrinatum</i> Pursh <i>Acer glabrum</i> var <i>douglasii</i> (Hook.)Dipp. <i>Actae rubra</i> (Ait.)Willd. <i>Alnus incana</i> var <i>occidentalis</i> (Dipp.)Hitchc. <i>Alnus sinuata</i> (Regel)Hydb. <i>Amelanchier alnifolia</i> Nutt. <i>Betula</i> spp. L. <i>Ceanothus velutinus</i> var <i>velutinus</i> Dougl.ex Hook <i>Cladothamnus pyroliflorus</i> Bong. <i>Cornus stolonifera</i> var <i>occidentalis</i> (T & G)Hitchc. <i>Crataegus douglasii</i> Lindll. <i>Lonicera involucrata</i> (Rich.)Banks <i>Menziesia ferruginea</i> Smith <i>Populus tremuloides</i> Michx. <i>Populus trichocarpa</i> T. & G. <i>Prunus emarginata</i> (Dougl.)Walp. <i>Rhododendron albiflorum</i> Hook <i>Rubus parviflorus</i> Nutt. <i>Salix</i> spp. L. <i>Sorbus sitchensis</i> Roemer <i>Spiraea douglasii</i> var <i>menziesii</i> (Hook)Presl</p>	<p>Vine maple Mountain maple Baneberry Thinleaf alder Sitka alder Saskatoon serviceberry Birch Sticky ceanothus Copper-bush Dogwood Black hawthorn Black twinberry Rusty menziesia Aspen Black cottonwood Bitter cherry White rhododendron Thimbleberry Willow Sitka mountain ash Menzies spirea</p>
--	---

REPORT ON A VISIT TO THE SWISS FEDERAL INSTITUTE FOR SNOW AND
AVALANCHE RESEARCH, WEISSFLUHJOCH, DAVOS, BETWEEN MARCH 19th
AND MARCH 27th, 1973

By R. J. Evans

The Institute is located at the summit of the Weissfluhjoch (2693 m.) and is directly accessible from Davos Dorf (1643 m.) by the Parsennbahn funicular railway. The Institute is not large, employing some 20 technical staff. The basic purpose of the Institute is to study snow and ice with particular regard to avalanching and to provide a service to the Swiss government of advice on avalanching. There are three sections at Weissfluhjoch under the directorship of Professor M. de Quervain. These sections and their leaders are Meteorology and Avalanche Forecasting (M. Schild), Physics of Snow and Ice (W. Good) and Ice Mechanics and Engineering (B. Salm). Two additional sections, Vegetation and Cloud Physics, are at different locations and were not visited. Facilities of the Institute include a library, cold room laboratories, a workshop and a PDP 11 computer.

The work of each section at Weissfluhjoch will now be described in some detail. The descriptions will not necessarily be complete, but will cover work which appears to have some relevance to avalanche research in the State of Washington.

Meteorology and Avalanche Forecasting

The basic purpose of this section is the forecasting of avalanche hazard for all of Switzerland (the Institute also serves as a meteorology station). This service is, however, purely advisory and any subsequent action to avert impending avalanche danger is not the responsibility of the Institute.

Basically, Alpine Switzerland is divided up into seven areas for the purpose of avalanche forecasting. From each region, snow and weather conditions are transmitted to the Institute and from these, under the direction of Mr. Schild, avalanche hazards are determined.

An interesting project is being developed by Dr. Fohn of this section, the ultimate aim of which is to have avalanche forecasting carried out automatically from digital information on snow, ground and weather conditions which will be read into a computer previously programmed to effect numerical forecasts. The project is very much in its infancy and Dr. Fohn is at present mainly concerned with identifying parameters which influence avalanche occurrence; the next step will be the correlation of these parameters. There is some skepticism at the Institute about the feasibility of such a scheme. It is felt that present avalanche forecasting depends to a large extent on experience and even intuition and that numerical encoding of such a procedure may well prove to be impossible. Clearly the success of such a scheme is critically dependent on the identification of all significant parameters; when all important parameters have been determined, then the numerical forecasting scheme could well prove to be effective. Parameter identification may, however, prove to be a difficult task and one which takes several years to complete.

Physics of Snow and Ice

The Physics of Snow and Ice section is small and consists essentially of Dr. Good and a technician. The main project is determination of the stochastically independent parameters which determine the physical properties of ice.

Thin sections from ice samples are taken and from these the statistical distributions of various physical parameters of grains are obtained. Parameters presently used include grain area, mean concave and convex radii of

curvature, and principal second moments of area together with their orientation. Statistical quantities are obtained directly from thin section photographs by combined use of analog and digital computation and pattern recognition routines. Of basic importance is the variance and covariance matrix of the parameters. From this matrix, principal values (i.e. eigenvalues) and eigenvectors are obtained and by inspection of the eigenvectors, it is possible to determine which parameters do not make a significant contribution to the physical description of the section. Application of the work to date has been to ice from boreholes from the Greenland Ice Cap and it has been shown that statistically independent parameters do not vary with depth. For relevance to avalanche research it is proposed to extend the work to snow and more importantly, to attempt to find relations between mechanical and physical properties by the same methods. Clearly the existence of such relationships is by no means certain but the project is significant, not only to snow and avalanche research, but to material science in general.

Snow Mechanics and Engineering

An increasing amount of alpine highway projects and resort construction has placed heavy demands on this section to provide consulting advice both in Switzerland and throughout Europe. Apart from Mr. Salm's basic work on the creep of snow samples, under both uniaxial and confined compression, there is relatively little research currently underway.

In an avalanche starting zone situated near the Weissfluhjoch summit, field experiments are being carried out to evaluate starting zone defenses. Numerous types of snow bridge are being used at various spacings both across and down the slope. There are now commercially available structural steel snow bridge components which are supplied in various standardized sizes consistent with the range required for design according to the Swiss "guidelines

for starting zone defenses". These snow bridge structures, considered to be ideal for bridge designs are of Austrian manufacture by Osterreichisch-Alpine Montangesellschaft of Vienna.

A further project situated below the starting zone defense area is concerned with the effect of small planted trees on glide.

It is interesting to note that the use of the above mentioned starting zone for experimental purposes is being discontinued. This appears basically to be a political decision due to the fact that houses have recently been built in the avalanche's path.

No theoretical snow mechanics research is presently being carried out at the Institute and the existing "guidelines" are considered to be adequate for design of defenses under European alpine conditions.

During the visit the research being carried out at the University of Washington was discussed both informally and formally through a seminar which dealt mainly with the snow mechanics aspects of the project.

DECISION METHODS

by C. B. Brown and E. R. LaChapelle

This report summarizes the findings and recommendations for management of avalanche hazard on the North Cascade Highway in the event that this highway should be kept open to public traffic throughout the winter. Based on the field reconnaissance and data collected for the Avalanche Atlas for this highway in 1971, some preliminary options were presented in the first Annual Report under the present contract ("Summary Report" dated September 1971). A formal systems analysis is now developed to evaluate such options and certain of these are examined through the method of detailed scenarios. Specific recommendations are also presented regarding required extent of snowshedding should this be elected as an option, as well as an analysis of path-by-path options for artillery control of avalanches.

These findings reflect an estimation of the avalanche problems and available methods of dealing with them which have been developed during the past three years of the contract. As such, they are based on current understanding of the state of the art in management of highway avalanche problems. We do wish to note as this report goes to press that current developments in our society as a whole may well require marked changes in these estimations in the near future. The developing energy shortage, especially as it affects transportation, may well influence both future patterns of traffic over the North Cascade Highway and the Department of Highways' posture in regard to the feasibility of snow plowing and avalanche control. We have also learned very recently that the availability of surplus or obsolete military artillery and ammunition, on which avalanche control techniques in this country have been

based for the past twenty years, may rapidly be coming to an end. A commercial artillery control weapon based on a rocket-boosted projectile is now under development through a U.S. Forest contract, but this will not in all cases be suited to the longer ranges often required for highway avalanche control. As we point out in the concluding section of these recommendations (2.7), no firm conclusions are possible. We can only point the way by which conclusions can be reached within the framework of rapidly changing circumstances.

TABLE OF CONTENTS

	Page
PART I BACKGROUND AND SYSTEM ORGANIZATION	111
1.1 Background.....	112
1.2 System Methods.....	115
1.3 Decision Criteria Functions.....	119
1.4 Utilities.....	122
1.5 Probabilities.....	126
1.6 Utility and Probability Values: The Delphi Method.....	131
1.7 Identification of Problems.....	135
PART II NORTH CASCADE HIGHWAY PROBLEMS	137
2.1 Introduction.....	138
2.2 Environmental Resources and Restraints.....	139
2.3 Problem Statements, Objectives and Criteria.....	141
2.4 Problem (a) - Alternatives and Evaluation.....	144
2.5 Problem (b) - Alternatives and Evaluation.....	146
2.6 Problem (c) - Alternatives and Evaluation.....	156
2.7 Feedback.....	159

TABLE OF CONTENTS,
continued

	Page
REFERENCES	160
APPENDICES	161
APPENDIX A: Scenario for Winter Closure, Early Spring Opening.....	162
APPENDIX B: from the Silverton Standard, Silverton, Colorado.....	166
APPENDIX C: An Algorithm to Define Constraints on Use of Artillery Fire for Avalanche Control and Application.....	167
APPENDIX D: Blind Firing Adjustment Design.....	171
APPENDIX E: Scenario for Winter Storm Sequence on Open Winter Highway Under Artillery Control.....	175

PART I

BACKGROUND AND SYSTEM ORGANIZATION

1.1 BACKGROUND

The study of the avalanche state on the North Cascade Highway in the north of Washington has been carried out by the University of Washington over the years 1970-1973. The results of this study have been of two types:

- a) scientific - where definite understanding of the snow characteristics of the North Cascades and of avalanche mechanisms have been obtained.
- b) operational - where the logging of avalanches, personnel training and specific advice on the local problems has been provided.

The scientific part has been reported in the literature ⁽¹⁾, ⁽²⁾ as well as in the annual reports of the project. The operational part has provided an avalanche atlas for the North Cascade Highway ⁽³⁾ and the various data in the annual reports.

In this report the operational methods for the North Cascades Highway are analyzed making use of all the scientific and operational information previously garnered. Rather than being repeated, this information is either systemitized in the Appendices or directly referenced.

The portion of the North Cascade Highway of interest here consists of 65 miles of mountain road with no feeder roads. Various view and camping sites exist but no telephone, communication, lodging or food facilities are available. The road is swept by 35 potential avalanche crossings in the Early Winter to Washington Pass region (see Fig. 1). Another 35 or more crossings exist outside this region. In 1971-72 the 35 avalanche sites had recorded 188 avalanches of which 102 swept the road. These were concentrated in the Cutthroat Ridge and Liberty Bell section.

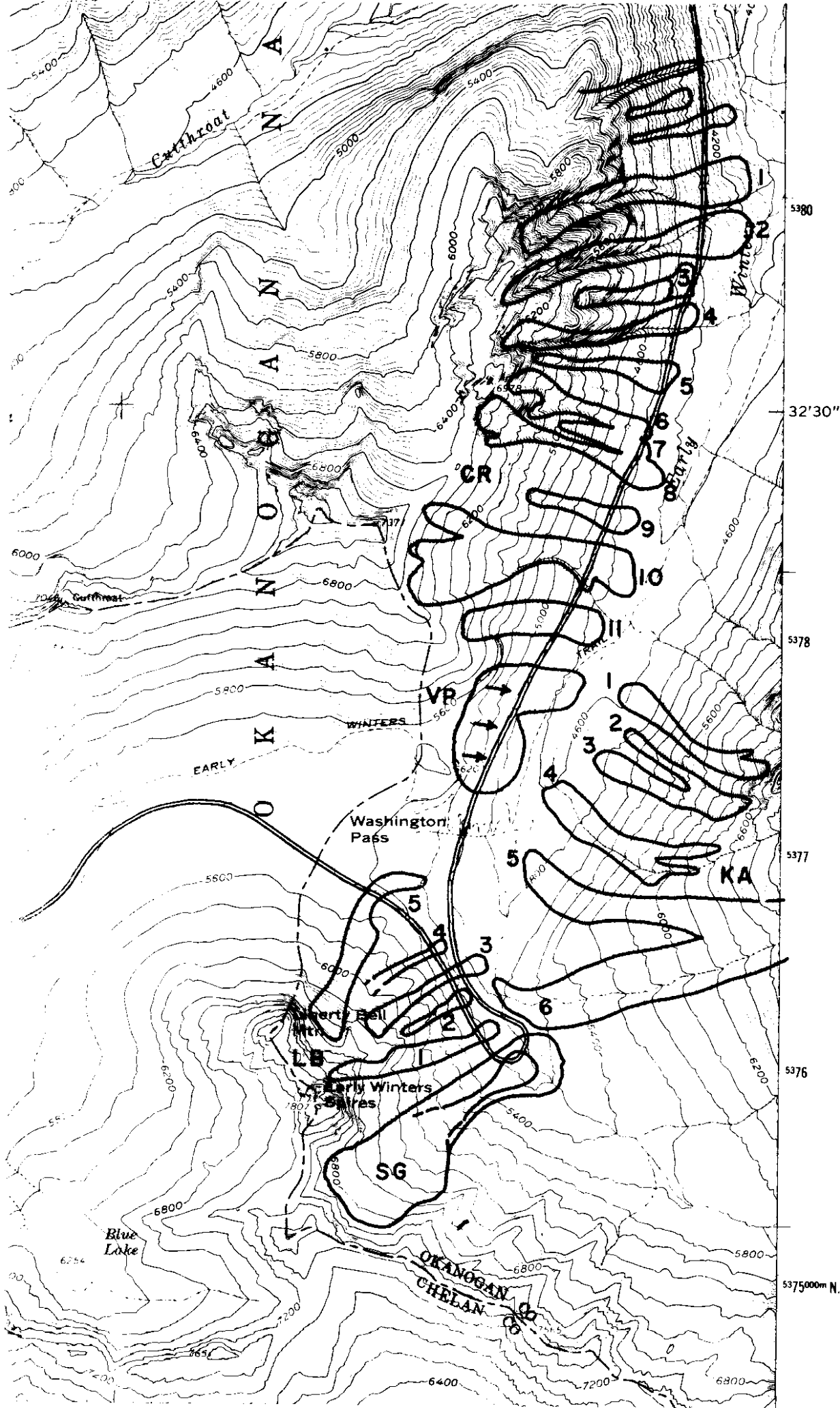

FIGURE 1a.

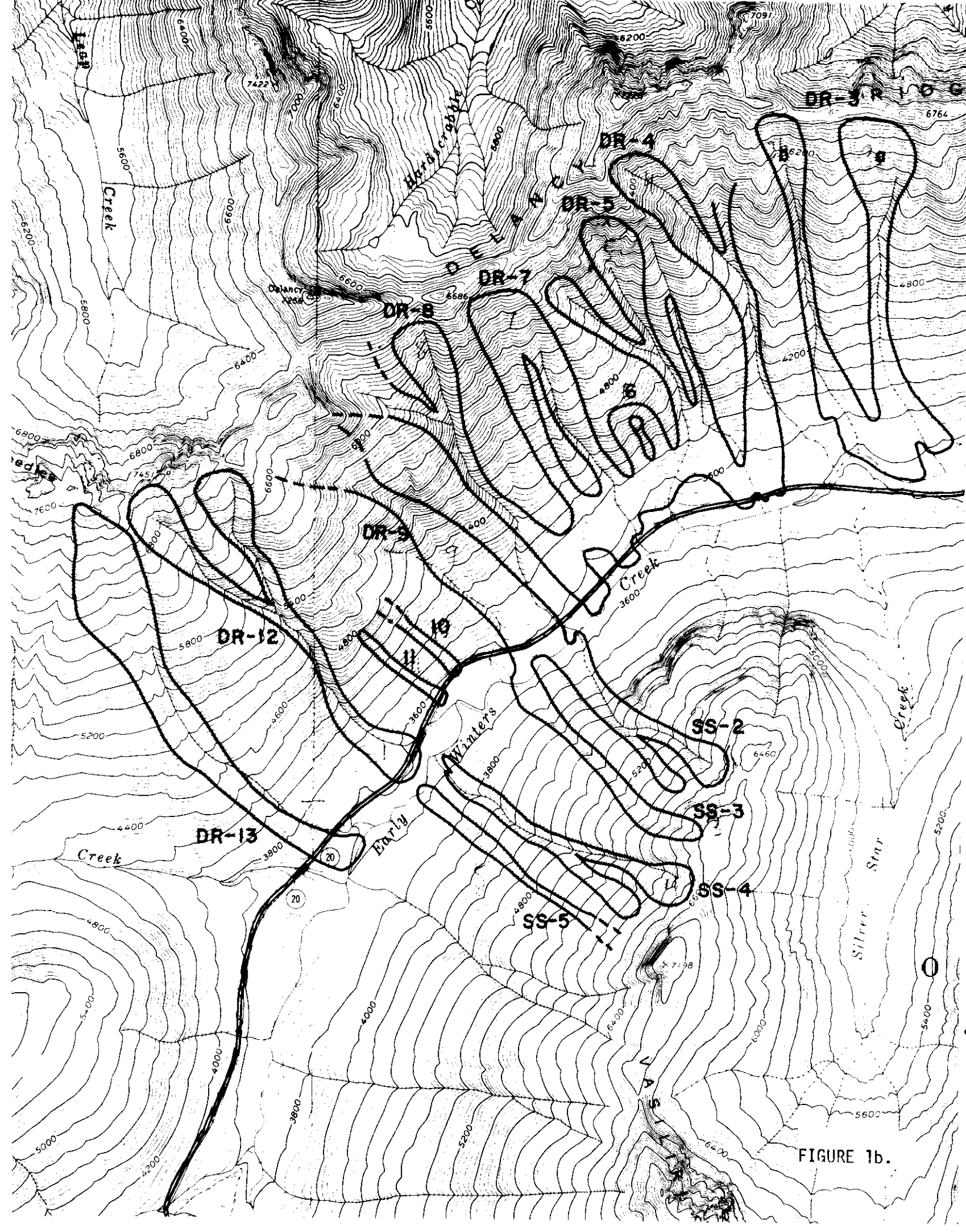

FIGURE 1b.

1.2 SYSTEM METHODS

As stated in the introduction the intention of the system analysis scheme is to translate essentially verbal qualitative ideas and information into a quantitative form. The verbal parts are:

- a) Objective
- b) Environment
- c) Criteria

Here the objective is often of a general, non-specific nature which can be accomplished only within the existing environment. Such an environment provides the resources which allow the accomplishment of the objective, but, also includes the restraints which limit or vitiate a wide range of possible alternatives. The general objectives, which are subject to definite restraints and resources, require that criteria be established which measure the effectiveness with which these goals are attained. Such criteria must be realistic and not re-define the intention of the objectives. A possible cynical example has been provided by Commissioner Mary Gardiner Jones of the Federal Trade Commission. She mentions that the avowed objective of all economic activity has been the welfare and interest of the consumer. The measure of success has been the size of corporate profit attained. If true, then there is an obvious dichotomy between the objective and criterion.

The establishment of criteria which allows measures of adequacy of objective attainment to be established leads to the generation of an exhaustive set of alternatives which meet these criteria. Among these alternatives is one which best meets the criteria and on which the decision will fall. Thus the analytical part of the system takes us from

- d) alternatives which satisfy (c)
to e) decision among the alternatives of (d).

The process is that of decision analysis which can be performed within the context of the decision tree in Fig. 2.

- 1) the n alternatives of (d) above (A_i)
- 2) for each alternative there are a number of states of nature that can occur. For alternative A_i these are θ_{ij} . As an instance, an alternative involving gun fire on the avalanche slopes may have two states of nature-controlled avalanching or no change in the snow slopes.
- 3) for each state of nature there is a probability of occurrence for θ_{ij} this is p_{ij} . The probability may be based on frequency observations and be objective or may be purely subjective. In either case methods of tightening the reliability of the value with experience will be involved.
- 4) also, for each state of nature, utilities have to be assigned. Thus, if θ_{ij} occurs, then this has a definite utility which is a combination of costs, fiscal benefits, social and environmental advantages, etc. The methods of assigning the U_{ij} to θ_{ij} will be formulated precisely.
- 5) finally, with A_i , θ_{ij} , p_{ij} and U_{ij} available, a criterion for decision of the most attractive alternative must be imposed. Such a criterion may be selected from maximum expected utilities, maxi-mini gains, mini-maxi regrets among others. A careful review of the most satisfactory criterion will be made so that the decision method can be completed.

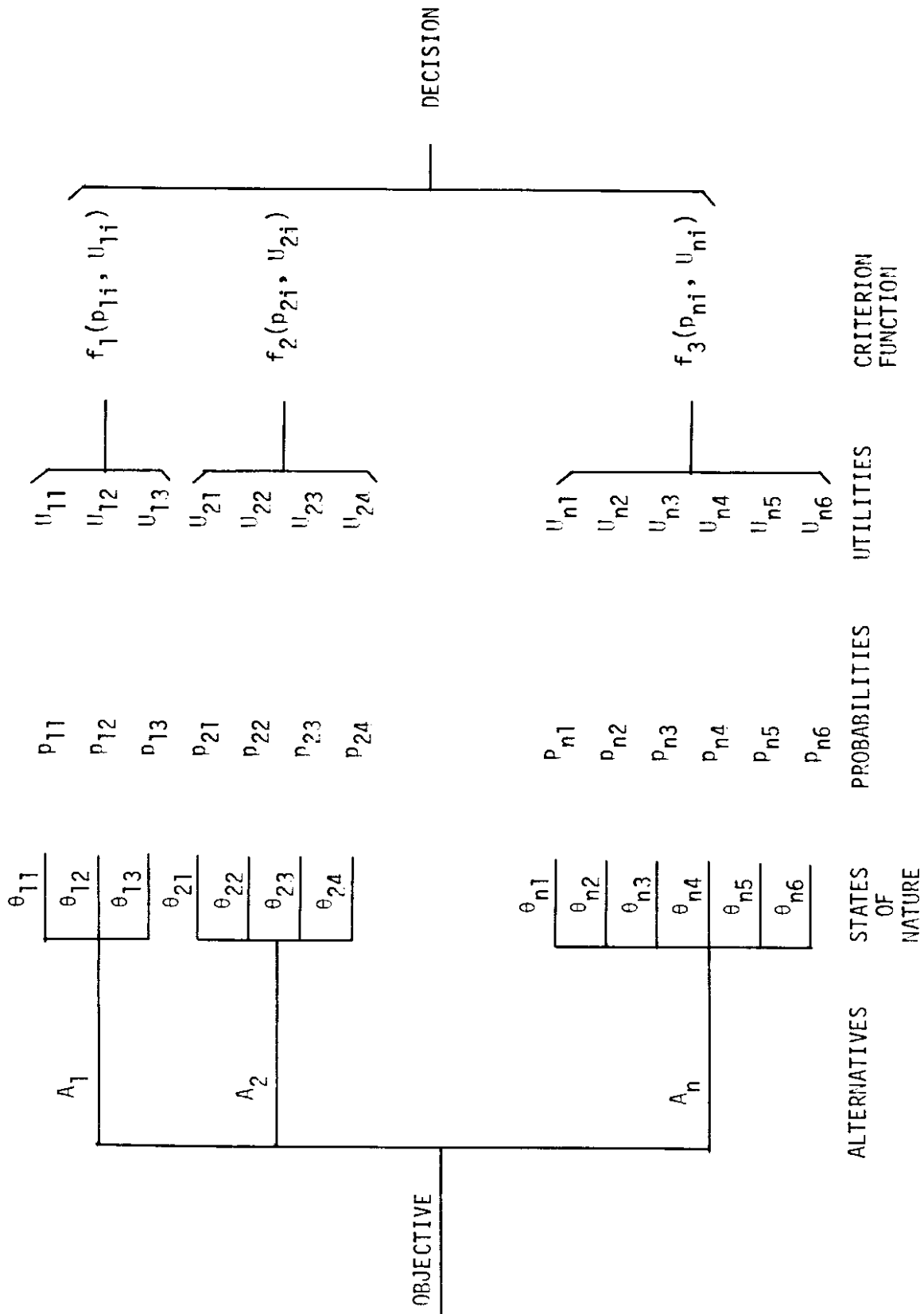

FIGURE 2

The final step of the system method is

f) feedback

Here the decision as implemented is compared to the original objective. It is essential that the comparison is with the objective of (a) subject to the resources and constraints of (b) and not with the criteria of (c). This then avoids the possible delusion that Commissioner Jones draws attention to. The feedback is part of an incremental process which allows changes in the decision to more closely reflect the objective. Thus, the decision maker is not over committed to a course of action without the availability of abandonment or change. Additionally, the incremental feedback allows a review of the viability of the stated objective and environment. A rephrasing of these statements will be essential in a dynamic system where trends and inclinations change. Dogma has very little place in the system methodology; more likely is a paradigmatic attitude to the objectives of a system.

1.3 DECISION CRITERIA FUNCTIONS

The functional forms of the decision criterion (f_1, f_2, f_3) in Fig. 2 may be expressed in many ways. Essentially a criterion must be established which allows a decision between alternatives to be made. The simplest form provides that alternative i is the decision when

$$f_i > f_j; j = 1, \dots, i-1, i+1, \dots, n \quad (1)$$

An often used functional form of f_i is

$$f_i(p_{ij}, U_{ij}) = \sum_{j=1}^k p_{ij} U_{ij} \quad (2)$$

where k is the number of states of nature of alternative A_i . This leads to an expected utility criterion when (1) is applied. The implication of this criterion is that the alternative action is repeatable and that on the average the return on the decision to employ alternative A_i would be a utility gain of f_i . If the utility is monetary then the criterion becomes that of an expected monetary value.

In the avalanche problem the alternatives used may not include the possibility of repeated experiments. The states of nature will occur so seldom that the proportions p_{ij} will not be maintained. Such a situation vitiates the expected utility criterion, where a repeated occurrence of the alternative must occur in such a manner that the p_{ij} is valid. A different type of decision criterion is called for which does not involve the averaging of gains over many reruns of alternative actions. A most conservative approach is to select the maximum of the minimum gains. This means that

$$f_i = U_i/\min \quad (3)$$

where U_i/\min is the minimum utility associated with alternative A_i . The inequality of (1) then leads to the decision in the alternative. Clearly,

this dismal approach anticipates the worst of all worlds. In this circumstance the decision makes the best of this sad state.

An examination of the consequences of the above decision (maxi-min of gains) can be obtained by considering regrets. In this case the maximum possible utility that can be obtained for the state of nature j is U_{\max}^j . The choice of alternative i has a possible set of nature θ_{ij} with utilities U_{ij} . For each state of nature, i , there is a value

$$F_{ij} = U_{\max}^j - U_{ij} \quad (4)$$

and for each alternative i , a value

$$F_i = F_{ij} |_{\max} \quad (5)$$

This is the regret felt by choosing A_i rather than the alternative which provided U_{\max}^j . For each alternative there will be a sequence of regrets, F_{ij} , in (4) and the greatest regret for A_i will be F_i in (5). In this situation the alternative selected will be that with minimum of these maximum regrets (mini-max regrets). The criterion of (1) with

$$f_i = \frac{1}{F_i} \quad (6)$$

can be used.

The states of nature for each alternative may not be alike. In this circumstance all states for all alternatives may be considered for each alternative, but when U_{ij} in (4) does not exist then F_{ij} can be assigned a value of zero.

The maxi-min of gains and mini-max of regrets do not include probabilities of the states of nature, p_{ij} . These can be subjectively included as weighting functions into the arguments which lead to (3) and (5). This then

provides an intermediate attitude between the repeated experiments of the expected utility criterion and the extreme, one only, experiment involved in the maxi-min of gains or mini-max of regrets criteria. Caution is necessary when such weighting is employed inasmuch as it tends to shift the decision towards that of a pre-conceived attitude. The exclusion of p_{ij} implies either that all states of nature are equally likely or that ignorance does not allow the investigator to assign to any state a pre-formed likelihood of occurrence.

The maxi-min gains do not necessarily give the same decision as mini-max regrets. The two criteria appeal to different classes of decision makers. In the offering of advice in which the advisor does not suffer - except professionally - from the consequences of his opinion, then the regret criterion is attractive. In many governmental situations this is the case; the decision involves public rather than personal utilities and money. Regrets can be sustained from the public purse even though professional and social retribution to the advisor may occur. Advice to a private client based on regrets, however, may lead to losses which the client has to sustain. Even though more cautious, the private client may appreciate advice based on gains.

1.4 UTILITIES

A requirement of the decision criteria previously outlined is that the utilities for the various alternatives be ordered. The utility of a preferable situation is then numerically larger than that for a less attractive situation. Then, with proper restriction on p_{ij} , the inequality of (1), which applies to all criteria, is applicable.

The utility for an alternative i when a state of nature j occurs, U_{ij} , reflects the monetary, social, legal and other consequences of related nature and states of nature. The requirement of order makes the scale associated with U_{ij} arbitrary. The real difficulty is in assigning values on the scale to the various U_{ij} for qualitative features such as social inconvenience. In this section the definition and assigning of utility values is formalized.

Consider two events A and R with consequences C_A and C_R . The probability of either A or R occurring is unity; of A occurring is p and R is $(1-p)$. The consequence of an event involving either A or R occurring is a mixture designated as $[p, C_A; (1-p) C_R]$.

If C_A is more satisfactory than C_R then a utility value on events A and R can be assigned such that

$$U(A) > U(R) \tag{7}$$

The mixture previously described is also an event, M with consequences, C_M , lying between C_A and C_R in the matter of acceptability. Indifference exists between C_M and a particular mixture of C_A and C_R when the correct value of p is employed. Therefore, we have C_A more acceptable than C_M which is more acceptable than C_R ; the measures of the utilities of Events A , M and R , with consequences C_A , C_M , C_R in order of acceptability are $U(A)$, $U(M)$, and $U(R)$, where $U(A) > U(M) > U(R)$. Indifference between M and a repeated

mixture of A and R exists when A has $100p\%$ of the occurrences and R has $100(1-p)\%$. Then this indifference is marked by*

$$U(M) = p U(A) + (1-p) U(R) \quad (9)$$

When the utilities for various states of nature of all alternatives A have been constructed, it is necessary to decide on the most acceptable and least acceptable combinations of alternatives and states of nature consequence. These may be monetary; that is, one consequence (alternative and associated state of nature) may involve a \$100,000 gain, another a \$20,000 loss. Of interest is the utility to be given to a \$10,000 gain. Here the most acceptable consequence is assigned a utility of 100, the least acceptable a utility of zero. In our example $U(\$100,000) = 100$, $U(-\$20,000) = 0$. We now ask for the value p such that we are indifferent between the certain occurrence of the intermediate event, M, with consequence C_M , (\$10,000 gain) and mixture $[p, \$100,000; (1-p), -\$20,000]$.

From (9)

$$U(\$10,000) = p \times 100 + (1-p) \times 0$$

A decision on p of 0.6 gives

$$U(\$10,000) = 60$$

From these arguments, the most favorable event is equivalent to A with monetary consequence of C_A and utility of $U(A) = 100$. The least favorable event is equivalent to R with consequence C_R and utility of $U(R) = 0$. The intermediate event is equivalent to M with monetary consequences C_m and

* The axiomatic treatment of arguments leading to (9) are dealt with in many books on game theory.

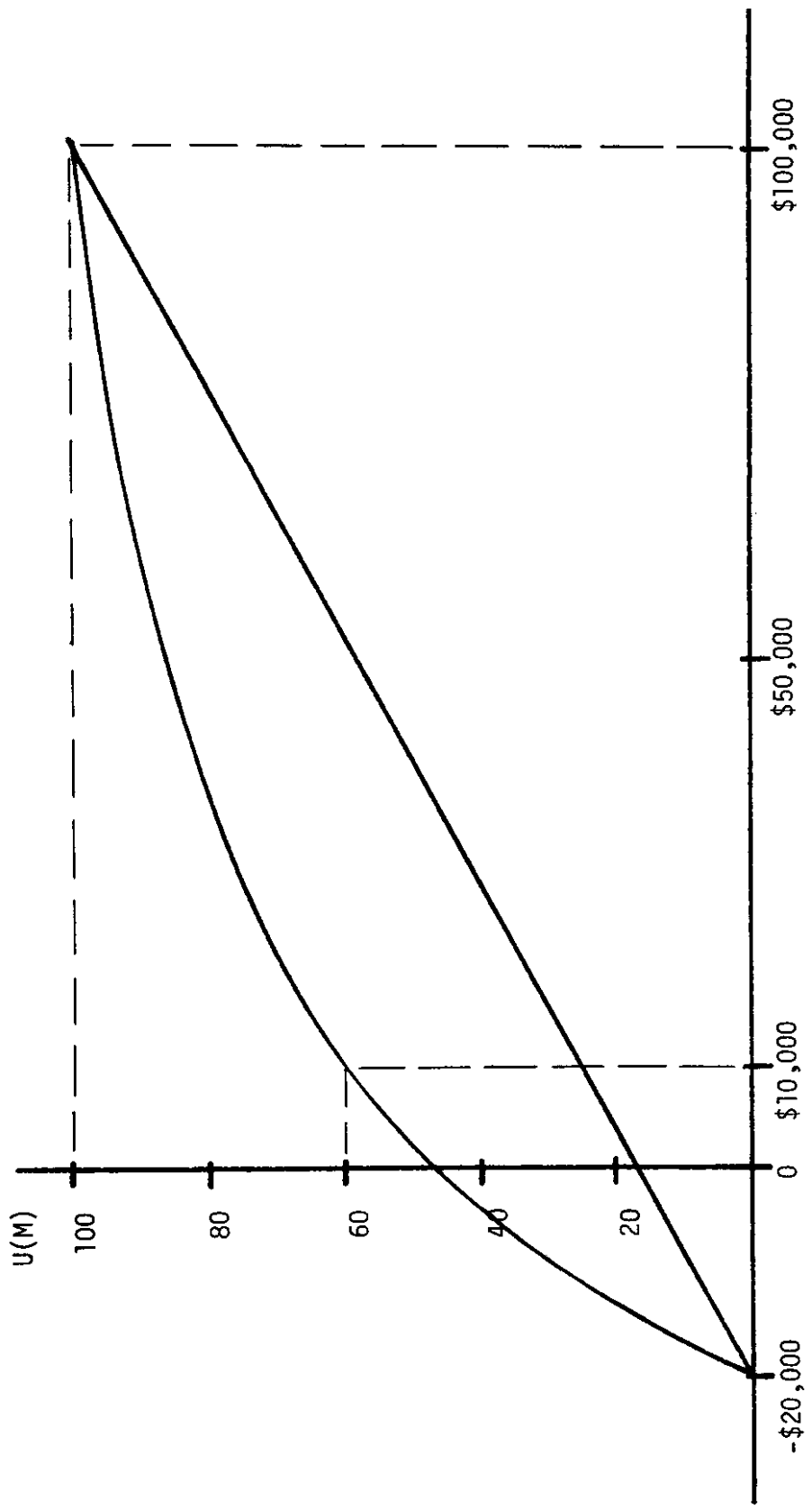

Figure 3

utility $U(M)$ is decided from (9) when the indifference probability p is determined. The results may be plotted on a utility to money graph like Fig. 3. Such a graph allows the decision maker to determine the utility for any monetary consequences in the range $-\$20,000$ to $\$100,000$.

The value of p , which is crucial in the determination of the $U(M)$, depends on the personal characteristics of the person or persons evaluating the utility values. A later section deals with the Delphi method of obtaining p when a large number of people are affected. This method is particularly pertinent to the construction of utilities where public confidence is involved.

Clearly the situation where the consequences are solely monetary allows a precise equivalence between money and utilities to be developed as in Fig. 3. More likely, however, are consequences which include a mixed bag with monetary, environmental, social and other ingredients. Here the arguments are the same as for the monetary situation although the determination of the most and least acceptable consequences are subjective. Again, the Delphi method can be helpful in determining these extreme consequences. Once obtained they are called events A and R and the previous analysis is repeated to determine $U(R) = 0 < U(M) = 100$.

It must be emphasized that the construction of the utility U_{ij} for each θ_{ij} must be completely independent of the chances of θ_{ij} occurring. These chances are expressed by p_{ij} and will be considered in the next section. This means that the U_{ij} is a measure of the value put on definite occurrence of θ_{ij} when alternative A_j is adopted.

1.5 PROBABILITIES

The previous development of the decision criterion required for each alternative, A_i , a function

$$f_i = f_i(p_{ij}, U_{ij}) \quad (10)$$

$j = 1$ to k states of nature for A_i

In the previous section the construction of the utility U_{ij} was considered. Here the probability p_{ij} of the state of nature θ_{ij} of alternative A_i occurring is studied.

Formally the p_{ij} must satisfy the axioms of probability which for application here means that

(a) $0 \leq p_{ij} \leq 1$ (11)

(b) probability of a certain event is unity. Thus, for A_i the k states of nature θ_{ij} must be exhaustive and

$$\sum_{j=1}^k p_{ij} = 1 \quad (12)$$

(c) probability of either one or the other of two mutually exclusive events occurring is the sum of the probabilities of these events occurring separately. Thus

$$p(\theta_{ic} \text{ or } \theta_{ij}) = p_{ic} + p_{ij} \quad (13)$$

The most important effect of these axioms is to ensure that the states of nature must be

- (1) exhaustive for each alternative
- (2) mutually exclusive

Only under these conditions can the assigned probabilities be employed in the decision analysis.

The probability value for the occurrence of state of nature θ_{ij} is termed p_{ij} . It is obtained from directly observed frequencies deductions, from indirect frequency observations and from subjective and intuitive feelings. The first process of using direct frequencies is clear. Already available are figures on the number of avalanches in various seasons at locations on the North Cascade Highway. Also available are the number of times in a season these cross the highway. These data can be incorporated into a direct frequency statement of probability with no difficulty. Thus, the probability of an avalanche crossing the highway a definite number of times in a season can be directly evaluated from these data.

The deductive approach can be illustrated by considering the weather data as indicators of avalanche susceptibility. The connection between weather and avalanche occurrence must be established; the probabilities of critical weather conditions can then be indirectly incorporated into probabilities of avalanche occurrence at a particular site.

Subjective probabilities reflect the experience and bias of individuals. For collective subjective probabilities the Delphi method is particularly applicable. The crux of the use of subjective judgments is based on the absence of complete frequency data either of the direct or deductive kind. This level of ignorance must be replaced by some quantitative statement. Even the statement that all states of nature are equally likely to occur is of positive value in the decision analysis.

New information allows for the improvement of the subjective probabilities. In this improvement Bayes' Rule is used. This rule states that

$$\bar{p}_{ij} = p(\theta_{ij}|R) = N p(R|\theta_{ij}) p_{ij} \quad (16)$$

where
$$N = \frac{1}{\sum_{j=1}^k p(R|\theta_{ij}) p_{ij}}$$

Here p_{ij} is the subjective, prior probability of the occurrence of θ_{ij} , R is new information based on experiments and is recorded in the probability statement $p(R|\theta_{ij})$. This has the meaning of the probability of R singular outcomes out of all the new experiments given that the state of nature is θ_{ij} . The new probability, p_{ij} , is defined as $p(\theta_{ij}|R)$ which is the probability of the state of nature, θ_{ij} , given the new information R . N is for normalization purposes so that

$$\sum_{j=1}^k \bar{p}_{ij} = 1$$

An example of the use of Bayes' Rule may be of value. Avalanches at a particular site have been determined from observation to have a probability of sweeping the highway in a given weather condition of 0.45. The question arises as to whether gunnery should be employed to control the situation. The alternatives are

A_1 - Gunnery

A_2 - No Gunnery

The states of nature are in the particular weather condition

$\theta_{11} \sim \theta_{21}$ - avalanches sweep the highway

$\theta_{12} \sim \theta_{22}$ - avalanches do not sweep the highway

The probabilities are

$$p_{11} = 0.7; p_{12} = 0.3$$

$$p_{21} = 0.45; p_{22} = 0.55$$

Here p_{11} and p_{12} are based on subjective estimates of previous experience; p_{21} and p_{22} are determined from frequency counts of previous years. The decision tree is shown in Fig. 4. The highway engineer, in an attempt to improve the probability statements p_{11} and p_{12} , proposes to explode a charge in the initiation zone at the critical weather state which may be considered as an effort to duplicate the effects of gunnery. Three outcomes are possible

- (a) no avalanching occurs $\sim R_a$
- (b) avalanching occurs which does not reach the highway $\sim R_b$
- (c) avalanching which reaches the highway occurs $\sim R_c$

This is the new experiment with results R_a , R_b , and R_c . The highway engineer determines from past experience that if the true state is that the avalanche sweeps the highway (θ_{11}), then

$$p(R_a | \theta_{11}) = 0.5$$

$$p(R_b | \theta_{11}) = 0.3$$

$$p(R_c | \theta_{11}) = 0.1$$

and if the true state is θ_{12} then

$$p(R_a | \theta_{12}) = 0.2$$

$$p(R_b | \theta_{12}) = 0.4$$

$$p(R_c | \theta_{12}) = 0.4$$

The explosion of the charge produces result R_b . Then

$$\bar{p}_{11} = p(\theta_{11} | R_b) = \frac{0.3 \times 0.7}{(0.3 \times 0.7 + 0.4 \times 0.3)} = 0.634$$

The assigned probability of the occurrence of θ_{11} has been changed by the experiment from 0.7 to 0.634. Also p_{12} has changed from 0.3 to 0.366.

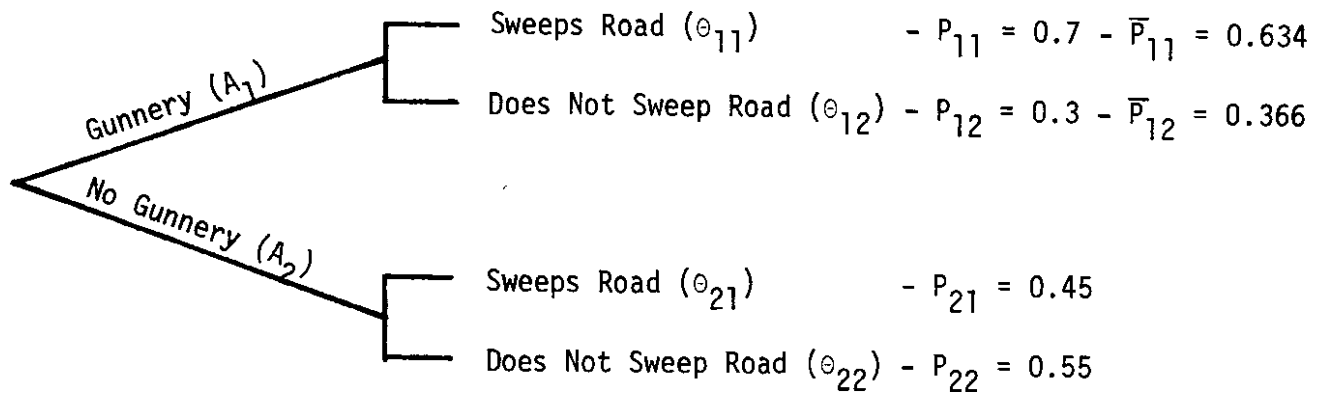

Figure 4

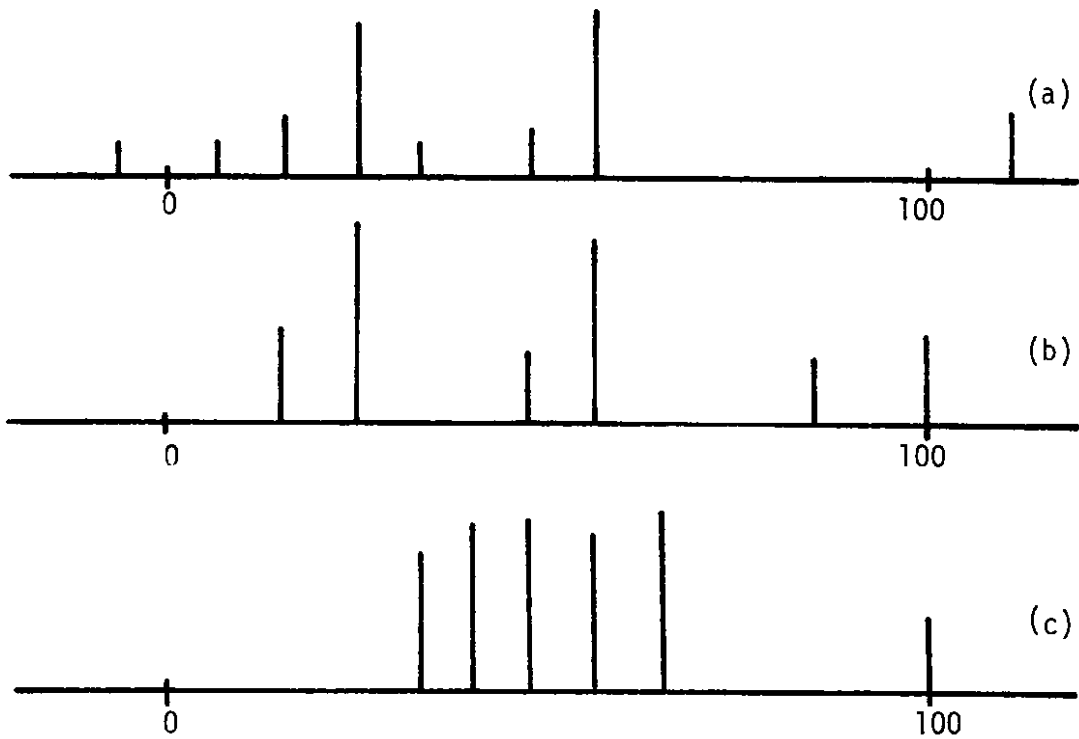

Figure 5 -- The Delphi Process for Utilities

1.6 UTILITY AND PROBABILITY VALUES

THE DELPHI METHOD

The process of obtaining both utility and probability values is an essential feature for subsequent decision making. In fact, once obtained, the decision is often apparent. A considerable discussion can occur in the establishing of these values. Like many discussions, they can deteriorate into arguments where the force of personality as well as clarity of thought can predominate. The avoidance of such biting situations is of great importance if utilities and probabilities, and therefore decisions, are to be the best obtainable.

What is required is a situation where all opinions can be fully expressed, all values considered, and all decision possibilities explored, but where the forensic skills and rank of individuals can be excluded. The normal committee table situation is not adequate. The arguments, when recorded and played back, are seldom sensible. What is wanted is a forum for a sensible argument.

In 1959 the Delphi method was introduced. Since then various modifications have been incorporated which provide additional sophistications. However, the main features are as follows:

1. The question is posed to the responsible group. The method of doing this is not too important as long as it is impersonal with no suggestion of the expected answer.
2. The members of the group respond with either an answer or the stated necessity for additional information or opinions. These responses must be written and anonymous. The responses are organized into distributions and tables.

3. The additional information and opinions are obtained in writing.
4. These data, opinions, and the organized previous responses are then distributed. The previous question is asked again and the responses, in the light of the distributed material, obtained and treated as before.
5. The cyclic repetition of this process leads rapidly to "tight" answers.

The advantages of the Delphi method are clear. Firstly, well paid and intelligent persons do not waste their time in senseless personal argument but do consider definite, unemotional data in the privacy of their offices, make a reasoned response, call for new information if necessary, and then proceed with other matters until the next round. The process really saves the time of respondents but is not conducive to quick decisions.

Additionally, oratory is removed from the situation. This does not mean that pure reason prevails; perceptive analysis of justifications is still essential, but this can be accomplished without the benefit of personalities.

The results of the Delphi method are that decisions on utilities and probabilities and professional engineering matters can be attained without insulting colleagues and without the feeling that one has been out-talked. The validity of the decision still depends on the wisdom of the group and the attention that is given to the question.

An example concerns the utility to be assigned with respect to road openings in winter through mountain passes. The Delphi method can be used. The road closed for the winter is assigned a utility of zero and the road kept open by continual ploughing and avalanche shooting, together with the provision of snow sheds, a utility of 100. The costs of a zero utility are objective (the economic loss) and subjective (the matter of convenience). The 100 utility also has a subjective part inasmuch as the inconvenience has been removed. The objective costs are the road works, the objective benefits are the economics of continual passage. The question is now asked -- what is the utility of providing sufficient protection and clearance facilities so that the road will be open except for a total of two weeks each year when exceptionally heavy snows occur and except for one year in five when it will be closed for two months? The costs and benefits of this are again subjective and objective. The objective can be spelled out, the subjective will be reflected in the choice of utility.

The situation is now shown in Table 1:

Prospect	Utility	Description	Objective Costs	Objective Benefits
1	0	Closed each winter	$\$A_1$	0
2	100	Open all winter	$\$A_2$	$\$B_2$
3	?	Partially open Closed every fifth year	$\$A_3$	$\$B_3$

Many may ask for additional data or the opinion of a definite person. The organizer obtains this information, provides it, and the distribution of Figure 5(a) to the group and then asks for a new estimate on the utility of

prospect 3. This is given in Figure 5(b) where more people respond. The process is repeated and the distribution of the utility of prospect 3 may look like Figure 5(c). The mean of this is 67 and a standard deviation can be obtained.

The Delphi process is concluded when the ratio of the standard deviation to the mean reaches some acceptable figure, say one-tenth.

Should the results be multi-peaked, then the prospects are probably not precise. There can be two obvious reasons for this. First, the information and prospect may be ambiguous. Second, two parts of society may have completely different utilities for the prospect. A possible separation may be between the inhabitants of one side of the mountain range and those on the other side. This probably means that the prospect has to be rephrased to reflect the benefits and costs to both groups as part of a common society. Then a "tight" uni-modal distribution should be obtainable.

The example shows a typical use of the Delphi method for utilities. It is equally applicable to the determination of the probabilities P_{ij} , and also to the probability p , necessary in equation (9) to obtain the indifference state between an event M and mixture A and R .

1.7 IDENTIFICATION OF PROBLEMS

After the previous review of the system format, the main problems associated with avalanche control on the North Cascade Highway can be identified. Of first importance is the decision as to whether or when the highway should be kept open all the year. This could be considered as an alternative in the general highway maintenance problem. (One alternative must be "do nothing" over the avalanche season.) Here it is chosen to consider the establishment of an all the year use highway as separate from the manner in which the highway is to be kept open.

The next problem selected is the decision on the best manner of maintaining an all season highway. This is a technical as well as operational problem with different solutions possible at different locations. Within this problem is concealed a major operational feature, namely the wisdom of continuing the present split responsibility for control and maintenance over the road between District 1 and District 2 Regional Offices. It is believed that this can be isolated as a separate problem, the decision to which affects the avalanche control regime.

Three problems will be dealt with in this report. They are

- a) Decision on whether to keep the road open.
- b) Decision on how to keep the road open.
- c) Decision on the administration of the operational schedule.

Before (a) can be attacked, some initial work has to be performed on (b) and fed back into (a). Before (b) can be undertaken, a firm decision must be made on (c). Therefore, although (a) may appear as the initial problem it is closely associated with a clear decision on (c) and initial proceedings with (b).

A fixed strategy for (b) that will be applicable arbitrarily in the future cannot be determined. The strategy must be flexible enough to allow for new technology, changing economic conditions and different social demands. This means that it is not reasonable to perform a decision study on problem (a) which will indicate that an all season road will be justified at a definite time in the future. Only initial studies of (b) should be used to determine whether the decision on (a) is to be positive. A two-year lead time can ensure that an optimum solution for (b) based on (c) can be staged.

PART II

NORTH CASCADE HIGHWAY PROBLEMS

2.1 INTRODUCTION

The second part of the report deals with the problems and possible solutions in the North Cascades Highway. First the background of Section 1.1 is extended to provide the full resources and restraints in the area. With these fully elaborated, the problems identified in Section 1.7 become more obvious. In particular the objectives are now sharpened and can be related to the criteria for meeting them. At this stage the verbal part of the work is completed and the various practical alternatives for meeting these criteria are then spelled out. The rest of the report consists of the evaluation of these within the systems' framework and subsequent feedback.

2.2 ENVIRONMENTAL RESOURCES AND RESTRAINTS

The environment in which the avalanche problem of the North Cascade Highway is considered falls into two parts; that connected with nature and the part imposed by human activity. This separation is common to most civil engineering problems and will be maintained here.

The natural environment consists of the terrain, weather and the resulting snow activities. The human impression involves the highway and the constructed environs together with the organizational system of the highway department and the road traffic.

The terrain is completely described in the Avalanche Atlas⁽³⁾. This atlas provides an accurate statement of the potential avalanche crossings of the road, the initiation zone conditions and evidence of the likelihood of avalanches. Avalanche activity for 1971-72 is available in the second annual report⁽⁴⁾ and for 1972-73 in the third report⁽⁵⁾. These reports^(4, 5) also provide weather information and the application of these data to avalanche forecasting is given in the work of LaChapelle and Fox⁽⁶⁾. Prediction theories have been developed by Brown, Evans and LaChapelle⁽¹⁾ and are also repeated in reference 4. Also, Brown, Evans and McClung⁽²⁾ have considered the use of glide measurements as an avalanche indicator. This is included in reference 5. The frequency of catastrophic avalanches can be indicated by these characteristics. These have been studied and are reported in reference 5.

The road location is shown in Fig. 1 and critical features are displayed in the Atlas⁽³⁾. The highway is intended to provide a scenic route and a restraint exists on any avalanche protection scheme namely that the opportunity for observing the scenery should not diminish. The traffic conditions

on an open winter highway are largely conjectural. Schemes for maintaining an all year road require definite assumptions about the traffic types and frequency. At the moment no branch roads leave the highway. This means that the destination of an entering vehicle is assured. The proposed schemes take account of this feature.

Administration of the highway is divided at the Granite Creek Guard Station. To the east the Wenatchee based District 2 controls the maintenance and clearing programs, to the west District 1 out of Seattle controls. Communications along the highway are restricted; phones only exist at the ends and intermediate points must be served by radio. Accomodations are not available, even on an emergency basis, along the highway.

In addition to the definite information cited, certain facilities may be called upon at a cost to maintain an open winter highway. These include operational facilities such as artillery and crews, cleaning crews, policing and escort crews. Capital expenditures in the form of avalanche sheds and walls, road relocation, informational signs and communication systems may be estimated and are considered in the various alternatives for keeping the highway open.

The three years' work in apparently diverse and unrelated fields reported in the annual reports (3, 4, 5) of the project actually provide most of the resources and understanding necessary to make decisions on the winter opening of the North Cascade Highway.

Reports on avalanche forecasting and defense procedures in Japan⁽⁴⁾ and Switzerland⁽⁵⁾ prepared by LaChapelle and Evans respectively are also available.

2.3 PROBLEM STATEMENTS, OBJECTIVES AND CRITERIA

In section 1.7 three problems were identified as being critical in winter highway decisions for the North Cascade route. There are:

- a) whether to keep the road open in the winter
- b) how to keep the road open in the winter
- c) how to administer the operational schedule

As stated, these problems are not independent; (a) can only be attacked after preliminary work on (b) has been completed. In a similar manner (c) must be concluded before the alternatives of (b) can be completely developed and yet the decision on (c) depends on the course of action adopted in (b).

The objectives of these problems now can be specified. They are:

- a) to determine whether to maintain the North Cascades Highway in the winter such that the social and economic advantages outweigh the costs.
- b) to determine the most economic, efficient and safe way of maintaining an open winter route at the minimum cost.
- c) to determine the most efficient, cheapest and safest organization for administration of the course of action decided in (b).

Criteria which establish objective attainment amongst the constraints and resources are required. With these problems here the criteria are as follows:

- a) for the first problem the objective is specific enough to include criteria. What is necessary concerns the method of determining which of two alternatives to take. In this situation the evidence of the closed winter highway is on hand whereas the evidence for the open highway is conjectural. This distinction is significant

when making a decision. Comparative expected values are not of equal validity. This means that either maxi-min of gains or mini-max of regrets will be the proper criterion. In this case where advice is being offered the criterion should be mini-max regrets as discussed in section 1.3.

- b) a decision to keep the highway open in (a) is predicted on some initial study of this problem. Now a more explicit exploration is justified. Specifically, the road cannot be kept open continuously through the winter except with such extensive shedding that it violates the maintainance of the scenic character of the highway. Here we would seek to keep the highway open for 350 days in the year and on 150 days the definition of open is that delays do not exceed four hours in the day and eight hours at night. On the remaining 200 days no delays are envisaged. The costs and utilities of the various alternatives fulfilling these criteria are uniformly nebulous. Also, our interest is in the long-term performance of the highway. Thus, with the dearth of snow in the 1972-73 winter one alternative would look very attractive whereas in a more average winter it would prove relatively expensive. Under these circumstances an expected utility of equation (2) with criterion (1) applying would be appropriate. A question arises whether the utility should include costs only and hence the criterion be maximum expected monetary gain (minimum expected costs), or whether the utility should include

more subjective aspects such as driver convenience. In this situation it is felt that the alternatives which meet the objective criteria subject to the restraints and resources of section 2.2 must be judged on a relative costs alone. Thus, the criteria are that the restraints and resources of section 2.2 limit the alternatives which provide for open highway for 350 days a year where 150 days will have maximum delays of 4 hours in the day and 8 hours at night. The safety provided under all alternatives should be no less than the statistical safety measures of a non-mountain road of similar dimensions and traffic. Amongst the alternatives meeting these criteria, the one with greatest expected monetary gain (least expected cost) should be selected.

c) The decision on the final problem affects (b) and yet, in turn, the choice for (c) depends on the alternative selection in (b). In (c) the various administrative alternatives must be continuously viable - not just in the winter season but throughout the whole year and for many years. This means that although the decision in (c) affects (b), the considerations in (c) are much wider than in (b). Additionally, the considerations in (c) involve not only costs but also administrative efficiency and safety. These aspects can best be realized by the expected utility criterion. The alternative selected should provide year round administrative convenience and equivalent road safety to that presently occurring in the State. Additionally, it should have the greatest expected utility as defined in equation (2) amongst all considered alternatives.

2.4 PROBLEM (a) - ALTERNATIVES AND EVALUATION

The resources and restraints on this problem are included in section 2.2 and the problem is formally identified, objectives stated and criteria constructed in section 2.3. Here the alternatives which meet the criteria and the evaluative procedures are given.

Two alternatives exist for this problem. They are:

A_1 - close the highway in the winter

A_2 - keep the highway open in the sense of the criteria of problem (b), namely 350 days a year with delay conditions on 150 days.

Clearly, A_1 is the existing state and evidence concerning the public attitude, costs and economic losses associated with the situation can be obtained. A scenario for the routine of operating A_2 is given in Appendix A. A_2 is a conjectural state at this stage. Possibly the public attitude can be anticipated as well as costs and economic gains. However, the evidence in A_1 is much firmer than in A_2 . The sensitive feature is the public attitude, containing the indications of economic frustration, personal inconvenience and the social paradigms of the time. The public attitudes are taken as the states of nature for both alternatives. Thus

θ_{11}, θ_{21} - favorable public attitude to the alternative

θ_{12}, θ_{22} - unfavorable public attitude to the alternative

Obtaining utilities for these states of nature will require extensive consideration. The Delphi method described in Section 1.6 is applicable here. In the first instance costs for the construction of facilities and operation

of A_2 can be estimated. The costs of operation when closed can also be obtained. Apparent economic benefits associated with A_2 can be made available. With these reasonable objective data, public attitudes can be tested by the Delphi method. Maximum and minimum utilities have to be established. It would seem that the small expenses involved in A_1 relative to A_2 would ensure that θ_{11} usually has the 100 utility value whereas θ_{22} (high costs, economic benefits and public displeasure) would have the zero utility. Utilities of θ_{12} and θ_{21} must be obtained by the methods of Section 1.6.

Evidence of p_{11} and p_{12} can be obtained by public poll. p_{21} and p_{22} will always be nebulous. Initially all p_{ij} can be assigned a value of 0.5 and the mini-max regrets decision can be obtained. For $U_{11} = 100$ and $U_{22} = 0$, as previously suggested, the alternative A_1 will always provide zero regrets for both states of nature and hence will be the chosen alternative. For θ_{21} the regrets of A_2 will be $(100 - U_{21})$ and for θ_{22} will be U_{12} . A change of decision to A_2 based on regrets can only occur when $U_{21} = 100$ with $U_{22} = 0$ and

$$U_{12} < (100 - U_{11}) \quad (17)$$

The above conclusions can be modified by using values of p_{ij} in the analysis such that the weighted utility is $p_{ij}U_{ij}$. For $U_{11} = 100$, $U_{22} = 0$ decision A_1 will always prevail unless both

$$\begin{aligned} p_{21} U_{21} &> 100 p_{11} \\ p_{12} U_{12} &< (p_{21} U_{21} - 100 p_{11}) \end{aligned} \quad (18)$$

For $U_{11} \neq 100$ similar arguments to those leading to equation (17) will be applicable to determine when the A_2 decision is correct.

2.5 PROBLEM (b) - ALTERNATIVES AND EVALUATION

The criteria for this problem given in section 2.3 provide for an expected utility solution based on an open highway on 350 days of the year with limited delays on 150 days. The resources and constraints are indicated in section 2.2. A standard of satisfactory operation on existing avalanche-swept highway is given in Appendix B. This is a newspaper report of the operation on U.S. 550 from Molas Pass to Red Mountain Pass (a distance of 17.6 miles) near Silverton, Colorado. In this section alternatives will be discussed before inclusion in the decision scheme.

1) Snow Sheds

These are feasible and can be recommended at sites where

- a) avalanche paths occur with sufficient avalanche frequency such that a favorable cost versus closure time utility exists.
- b) the terrain is adaptable to shed construction (the wide talus fan is hard to defend against with sheds, whereas well-identified narrow paths can be defended). The sheds must be long enough; the hazards of limited sheds subjected to overruns at the ends in large avalanches have been extensively documented. Diversion walls which channel avalanche paths can be often economically used to reduce and define the length of sheds.

Table 2 gives suggested arrangements of snow sheds. It should be noted that the Cutthroat Ridge section has virtually continuous shedding. A question concerning the appropriateness of a 2-mile snow shed on a scenic highway can certainly be raised. Conventional in-situ construction costs of \$1,000 per foot can be anticipated. Extensive precasting may reduce this to \$600 per foot.

TABLE 2

PRIMARY SNOW SHED SITES

<u>Path</u>	<u>Length of Shed, feet (map measure)</u>
Newhalem No. 1	400
2 & 2a	600 (single shed)
5	600
6	300
9	700
	<hr/>
	2600 total in Skagit Gorge
Ruby Mtn. No. 9	250
10	400
	<hr/>
	650 total Ruby Mtn.
Liberty Bell No. 1	500
2	200
3	200 (upper) 500 (lower - difficult to build)
4	200
	<hr/>
	1600 total Liberty Bell
Cutthroat Ridge	
CR-1 thru VP	10,400
CR-1 thru CR-11 only	8,000
Primary snow shed construction totals:	
Newhalem Slides	2,600
Ruby Mtn. Slides	650
Liberty Bell Slides	1,600
Cutthroat Ridge Slides	10,400
	<hr/>
	15,250 total

In addition to the shedding, extensive artillery control is suggested in the Whistler Mountain and the Delancy Ridge road sections. Less frequent artillery control is applicable along Granite Creek. On the Whistler Shoulder no initial shedding is proposed. However, the experience, as encompassed in the feed back system, may indicate the virtue of a long snow shed of about 1800'. Site SG is not suitable for shedding and a diversion wall is suggested.

The alternative considered here requires shedding, diversion walls, artillery control and plowing equipment and personnel.

2) Snow Sheds and Relocation

Two-thirds of the sheds proposed in alternative (1) occur in the Cut-throat Ridge section. A relocation of the highway to the opposite side of the valley is a serious alternative. On this, the Kangaroo Ridge side, the avalanches are narrower and manageable by artillery control and plowing. Thus, the cost of about 2 miles of shedding may be offset by relocating the highway and the provision of artillery and plowing to maintain the useage. Fig. 6 indicates a possible re-alignment:

3) Artillery Control

The purposes of artillery control are to eliminate avalanche hazards and to modify clearing costs by reducing the number and size of avalanches reaching the highway. To accomplish these purposes the highway must be cleared of traffic under the slide path and possibly from adjacent paths which might slide when initiated by gunnery on the path of interest. The gun and crew have to be located in a correct firing position which is safe. This safety aspect is crucial throughout the whole operation; gun location and firing sequence must be such that the crew are not trapped between falling avalanches.

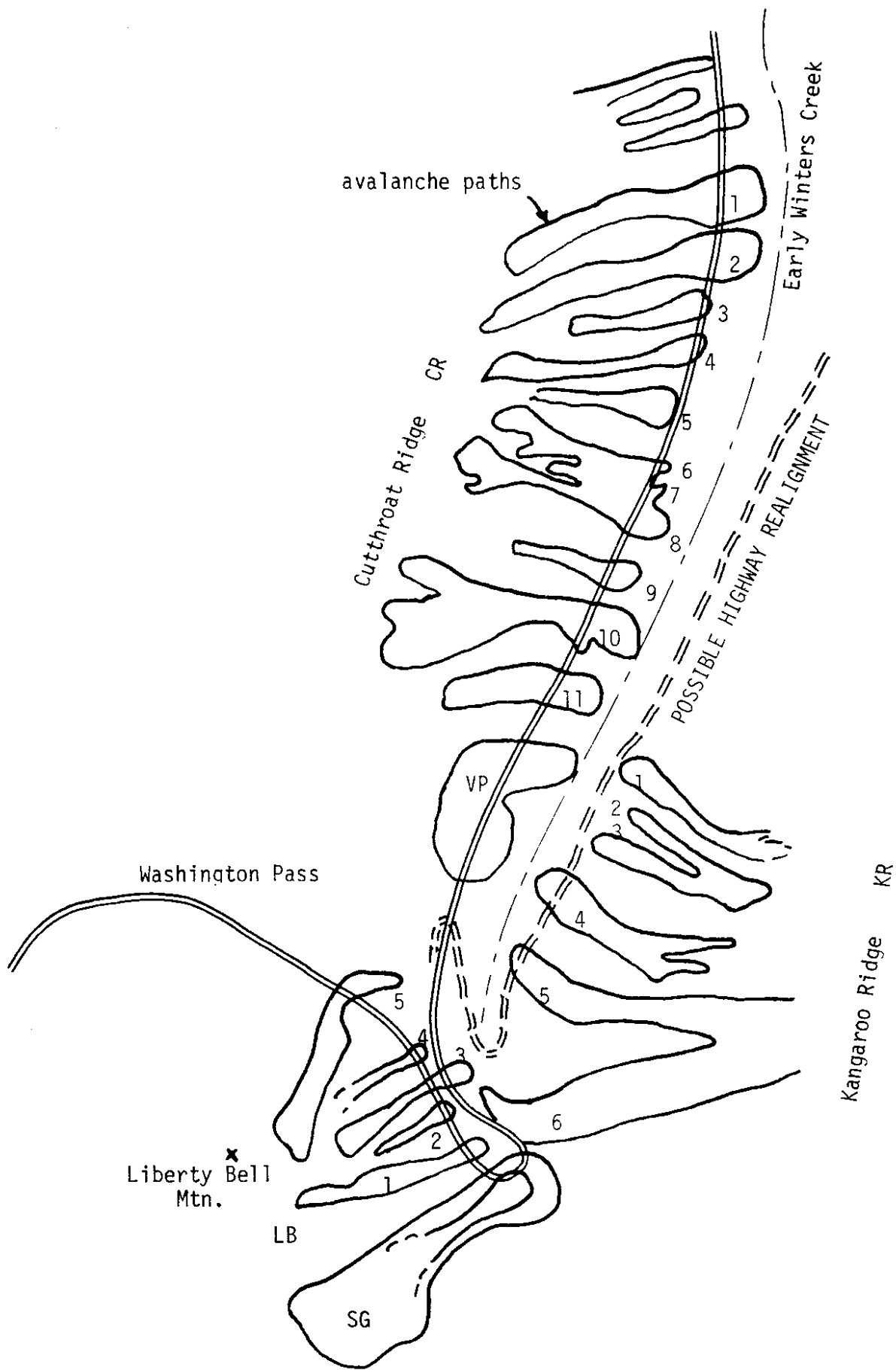

Figure 6

Additionally, for operational as well as safety purposes, radio communication between the gun crew and road blocks is essential.

A decision to begin artillery control on a given avalanche path is predicated on

- a) the forecast of impending natural avalanche
- b) observed occurrence of natural avalanches in the vicinity
- c) evidence of snow instability displayed by artificial release on adjacent paths.

Closures should be initiated, if possible, at least two hours in advance of avalanche control work. This allows the road to be cleared so that vehicles will not be trapped between avalanches.

The action of using artillery at a given site and time leads to definite results which must be identified. These results set up new situations which require additional decision making. Results and possible decisions are given below:

- a) avalanche falls and blocks the highway. The remaining snow and snow on other paths may now be in an unstable state. A decision to extend the control measures to surrounding sites, and to continue the existing control work would be likely. The highway would be held closed.
- b) avalanche falls short of highway. The same conditions as (a) may exist. A subjective decision on the hazard on other paths is required. If they are hazardous then the decision of (a) must be reached. Otherwise existing control on the site of interest is continued and the highway is held closed.

- c) snow fractures but does not fall in the release zone. Investigation of the stability there and in adjacent paths must be carried out. Additional control work is usually required with the highway held closed. Control work is terminated when the snow proves to be stable.
- d) snow unaffected. The snow is stable on the path of interest but may be in an incipient failure state on surrounding paths. Decisions concerning the danger in surrounding sites have to be made and control work extended to them or terminated.

These results are fully observable only when excellent visibility exists. In poor visibility (a) and (b) can be detected whereas in blind conditions of night or storms only (a) can be detected.

A proper methodology is necessary to determine the suitability of a given site for artillery control. This has been developed and the consequent algorithm is given in Appendix C. The application of the algorithm to the North Cascade Highway is also given in Appendix C. Consequences of this use are:

- a) a vehicle-mounted 105 mm. recoilless rifle is necessary to the west of Washington Pass with provision for transfer to towers at WM, WS and at WSE.
- b) two 105 mm. recoilless rifles necessary to the east of Washington Pass. One will be vehicle-mounted with provision for transfer to towers. One will be a fixed-mount tower gun located near Washington Pass Overlook in a position for control of LB, KA, and SG. Only VP is not controlled between the Pass and CR. Hand charges and/or avalauncher from the Overlook gun position will be used to control VP.

The technical difficulty of gun transfer from vehicle to tower as presently accomplished at Stevens Pass is time consuming and the delays in moving to at least six towers between Rainy Pass and DR-1 would negate the system. With this in mind a vehicle acting as a gun platform and vehicle positioning facilities (which allow the accurate blind firing essential on the North Cascades Highway) has been specially designed. The design features are provided in Appendix D.

Additional to the guns, the following will be necessary for artillery control:

- a) snow camps at Swamp Creek and Pine Creek
- b) complete radio communication system
- c) full complement of snow-plowing equipment working out of each snow camp and Newhalem
- d) full time resident observer control technicians at Washington Pass and Newhalem - Diablo. Relief observer technicians operating from the snow camps in rotation.
- e) marking of avalanche paths with signs and a warning system in effect on east and west approaches to the North Cascade Highway.

With these facilities available the artillery control scenario for action in a typical winter storm is given in Appendix E.

Three possible alternatives for meeting the criteria of section 2.3 have now been described in some detail. These coupled with the description of winter closure operations given in section 2.4 and Appendix A, provide a basis for considering in detail a range of options for action on the North Cascade Highway. The three alternatives of this problem are:

A_1 - snow sheds

A_2 - snow sheds and relocation

A_3 - artillery control

The states of nature for the three alternatives can now be considered. Each of these alternatives meet the criteria which are based on statistical expected values. However, the likelihood exists of a rare condition or season in which the criteria cannot be met over a short period of time. In this situation, not only can the delays exceed the allowable and the closing exceed 15 days, but also the requirement of section 2.3 that "The safety provided under all alternatives should be no less than the statistical safety measures of a non-mountain road of similar dimensions and traffic" may not be met. These long term statistical measures may be violated in a given short time and the alternative considered would be temporarily ineffective. If all alternatives meet the long term criteria but possibly fail in a given season or period, then the occurrence or non-occurrence of such failures can be considered as states of nature for all alternatives. Then

$\theta_{11}, \theta_{21}, \theta_{31}$ - The meeting of the criteria at all times

$\theta_{12}, \theta_{22}, \theta_{32}$ - Failure to meet the criteria once in a given time, T , are the states of nature.

The time T must be substantially smaller than the time extent of the statistical means used in the criteria but be long enough to be reasonably acceptable to the public. For instance, although the criteria may be met by an alternative it would not be acceptable if it failed every-other year. The data available for long term measures will be based on at least 10-year records; with this in mind a time T of 5 years would be acceptable to the public and

meet other specified requirements.

The probabilities of occurrence of the states of nature are now specifiable as:

p_{i2} - probability of θ_{i2} occurring once in five years for alternative A_i

These probabilities are partially subjective but will also depend on frequency of unusually severe winters and the frequency of prolonged adverse conditions in any winter season. The Delphi method detailed in section 1.6 may be employed. The participants will base their responses on their own understanding of the problem together with the data, information and knowledge provided in the reports and papers of references (1.6)

The decision criteria given in section 2.3 is that of maximum expected monetary gain (least expected cost). This means that the utilities are expressed as money. The money involved must include not only the initial costs of construction, relocation and purchases but also the continuous costs of operation and maintainance. For A_1 and A_2 the initial costs will be high whereas the continuing expenses will be negligible compared to A_3 . It is necessary to refer all these costs to a common outlay so that comparisons may be made. It is suggested that the cash flow series be represented as the present worth where \$p at N years in the future is equivalent to $\frac{\$p}{(1+i)^N}$ at present. Here i is the discount rate time 10^{-2} .

The time over which the continual costs should be considered is a delicate matter for consideration. The financial aspect suggests that the time necessary to pay off construction bonds and the value of i above are important. On the other hand the time for which a road meets changing contemporary standards of acceptability provides an important criterion. A time of 20 years would seem

to meet both of these requirements. Thus, the monetary utilities can be obtained using the assigning techniques of Section 1.4 and, if necessary, the impersonal methods of 1.6.

With U_{ij} and p_{ij} available comparisons between $(p_{11} U_{11} + p_{12} U_{12})$, $(p_{21} U_{21} + p_{22} U_{22})$ and $(p_{31} U_{31} + p_{32} U_{32})$ can be made with smallest sum being the alternative chosen.

2.6 PROBLEM (c) - ALTERNATIVES AND EVALUATION

The discussion of the criteria for problem (c) in section 2.3 indicated that the organizational decision should relate to year round operation of the highway and not be based exclusively on the winter characteristics. In this section we will be occupied with the winter operation of the highway; the other aspects of organization may be included by the Department of Highways.

Alternatives A_2 and A_3 in section 2.5 demand a single line of responsibility for successful winter operation. The static control by snow shedding in alternative A_1 does not make the single line as critical but the general plowing and winter maintenance can best be completed under a unified direction.

The organizational requirements of operation are:

- a) adequate field facilities. These include observer stations, signs (possibly operated by remote control), communications, snow and maintenance camps. Signs should mark all avalanche paths (examples "Ruby Mountain No. 9 Avalanche Path: No stopping next 0.1 mile" and "End Avalanche Path"). Communication facilities must include two-way radios in all vehicles and snow plows together with reliable repeater stations. These radios should be linked to City Light. Transmittal of closure notices to critical access points such as Sedro Wooley and Marblemount, Twisp and Winthrop must be possible.
- b) a forecasting net made up of coordinated avalanche and snow observing and forecasting organizations at Washington Pass, Diablo, Stevens Pass and Snoqualmie Pass. This net requires complete communications with a forecaster and meteorologist located centrally (preferably on

the North Cascade Highway). Forecasts will then be available for all passes. It is anticipated that the North Cascade Highway will be the dominant problem, followed by Stevens and Snoqualmie Passes. Important gains in efficiency, economy and personnel development are possible if a unified avalanche forecasting and control exists for all the Cascades.

- c) frequent patrols which are continuous during snow fall and avalanche hazard periods. It is essential to completely cover the highway after closure to ensure that no one is stranded in the wilderness.

Additional to these organizational requirements it will probably be necessary to provide courtesy service trucks to broken down vehicles. It is essential to keep traffic moving; serious problems occur when vehicles are trapped by closures and avalanche falls. In spite of all this care, food, lodging and toilet facilities have to be provided at Washington Pass. It should be pointed out that the provision of these facilities on a designated scenic highway may possible and properly be contested by the Park Service, Forest Service and environmental groups. This is especially so in areas managed as a quasi-wilderness. Similarly, the construction of snow sheds and defense structures may be contested.

Finally, a possible mode of operation during snow fall and potential avalanche hazard periods is to convoy the traffic behind snow plows and terminated by a control vehicle. This greatly simplifies the winter operation and yet demands a single responsibility source.

Having in mind the objectives of section 2.3 and the organizational requirements given in this section it seems imperative that a unified systems

approach geared to an administrative structure and operational methods tailored to the problem be employed. This is the winter background to establishing alternatives A_1 and A_2 on the operational problem. The other scenarios must be provided by the Department of Highways. The alternatives are:

A_1 - maintain the present Districts

A_2 - unify the organizational operation

The remainder of the decision problem requires the non-snow highway operation features. However, as far as winter operations are concerned, a unified operation is essential and A_2 must be provided.

2.7 FEEDBACK

No conclusions are possible in a study of this nature. Instead, an insistence on a feedback system must be advocated. No decision will completely meet the objectives; improvements and even complete reversals may be required.

A program takes time to formulate and complete; during this time social and physical changes may occur which may alter the objectives, constraints and resources of the projects. The continual updating of all these facets is essential. Changes in evidence on which probabilities are based may also happen; adjustments may be made in the light of Bayes' rule, as given in section 1.5. Utilities, especially the non-monetary features, may change over a period of time. Such changes seem to be more rapid in recent years than previously and an alertness to social attitude must be maintained. A regular investigation of utilities by the Delphi method described in section 1.6 is suggested.

Apart from these external changes which affect the whole problem undertaken, it can often transpire that the criteria do not properly reflect the objectives of the problem. A critical test for this can be made by examining the extent to which the alternative decided on actually meets the objectives. By definition it must satisfy the criteria but the examination with respect to objectives is the real test for the success of the project. This means that all feedback must be from the implemented decision to the objectives.

REFERENCES

1. Brown, C. B., R. J. Evans and E. R. LaChapelle (1972), "Slab Avalanching and the State of Stress in Fallen Snow", Journal of Geophysical Research, Vol. 77, No. 24.
2. Brown, C. B., R. J. Evans and D. McClung (1973), "Incorporation of Glide and Creep Measurements in Snow Slab Mechanics", Advances in North American Avalanche Technology: 1972 Symposium.
3. LaChapelle, E. R. (1971), "Avalanches on the North Cascades Highway, (SR-20)", Avalanche Atlas and Summary Report, prepared for the Washington State Highway Commission.
4. LaChapelle, E. R., C. B. Brown and R. J. Evans (1972), "Methods of Avalanche Control on Washington Mountain Highways", Second Annual Report, Research Report Y-1301, prepared for the Washington State Highway Commission.
5. LaChapelle, E. R., C. B. Brown and R. J. Evans (1973), "Methods of Avalanche Control on Washington Mountain Highways", Third Annual Report, Research Report Y-1301 (earlier material in this report), prepared for the Washington State Highway Commission.
6. LaChapelle, E. R. and Terence Fox (1973), "A Real-Time Data Network for Avalanche Forecasting in the Cascade Mountains of Washington State", Interdisciplinary Symposium on Advanced Concepts and Techniques in the Study of Snow and Ice Resources, Monterey, California, December 2-6, 1973.

APPENDICES

APPENDIX A

Scenario for Winter Closure, Early Spring Opening*

Assumptions:

- 1) North Cascade Highway (NCH) is in present state with no avalanche defenses or snow sheds.
- 2) Highway will be kept plowed to lower Granite Creek in west and to Cutthroat Creek on the east during the winter. Closed to traffic Diablo to Mazama.
- 3) A resident observer at Washington Pass will maintain daily snow and avalanche records and communicate these to Highway Avalanche Network.
- 4) Part-time observer in Diablo-Newhalem area provides daily snow and avalanche reports to avalanche Network.

Autumn Mode

Highway normally will be kept open through hunting season, except for unusually heavy snow storms.

Light snowfalls are plowed out over passes, with one heavy push plow with throwing blade working between Granite Creek Crossing and Pine Creek. This plow is called up from Mazama whenever Washington Pass (WP) observer reports snow accumulation.

WP observer, working together with Highway Avalanche Network forecaster (HF), relays heavy snow warnings to NCH maintenance crews. Highway is patrolled with plow at start of storm to sweep highway clear of traffic, then gates are closed at Pine Creek on the east and Lower Granite Creek or Thunder Arm on the west.

*Corresponds to Option 2 in 1971 Report.

According to lateness of season and depth of snow on passes, the highway may or may not be plowed out following a heavy snow storm at discretion of maintenance foreman.

WP observer keeps special watch for avalanches during and after a heavy autumn storm. The first avalanches to cross the highway normally will fall from Liberty Bell and/or Cutthroat Ridge. The highway is closed for the winter when these avalanches fall in any size. If temporary clearing of the highway is required following avalanching, the WP observer plus HF furnish recommendations on safe times to plow.

No autumn avalanche hazard normally is expected in the Skagit Gorge prior to winter closure (typically early November). Unusual circumstances in this area are dealt with by HF.

Winter Mode

Highway kept plowed intermittently from Diablo to Granite Creek Crossing and from Mazama to Cutthroat Creek. Plowing schedule discretionary according to winter snowfall and equipment availability.

Plow operators check with WP observer and/or HF to confirm low avalanche hazard before plowing these zones.

Following avalanche falls from Ruby Mountain, Lower Granite Creek, Delancy Ridge, additional equipment (rotary plow, bulldozer) is required. During clearing operations for these avalanche paths, WP observer maintains special watch and advisory on hazard conditions, consulting with HF for general weather conditions. Observer and/or HF recommend breaking off clearing operations if new hazard develops.

Newhalem-Diablo (ND) observer maintains daily data exchange with Avalanche

Network and monitors Sourdough Mountain temperature telemeter. Early warnings of weather patterns favoring avalanche hazard in Skagit Gorge are transmitted by HF. Closure decisions for the Gorge are determined on an hour-to-hour basis with aid of the temperature telemeter by ND observer and maintenance foreman.

ND observer in consultation with HF recommends when hazard has diminished in the Gorge and clearing operations can begin for any fallen avalanches.

During clearing operations in the Gorge, ND observer coordinates information on local conditions and weather reports from Avalanche Network. Observer and/or HF may recommend plowing be terminated if hazard rises again. He also can serve as warning lookout during plowing.

Spring Mode

(It is assumed that with accurate snow and avalanche data from Washington Pass and an operational forecasting program, plowing out the highway from Granite Creek Crossing to Cutthroat Creek can be done safely by careful choice of plowing times at any time in late winter or spring. The problem is to avoid plowing too soon, especially east of Washington Pass, and having the roadway refilled by new avalanches.)

Plowing between Granite Creek Crossing and Rainy Pass begins early in spring, working toward higher elevation as season advances. Avalanche Network coordinates work schedule with general meteorological patterns to avoid plowing too early and having plow cut drifted in by spring snow storms. Rotary plow normally is required. If large avalanches have reached the highway from GC-5 through GC-15, a bulldozer may also be required.

Snow and avalanche data from WP observer provide basis for estimating

timing and magnitude of spring wet slide cycle. Plowing from Rainy Pass to Cutthroat Creek, working from both ends, begins after snow pack is deemed reasonably stabilized (coordination between WP observer and HF).

During plow-out of main avalanche zones, WP observer assist with look-out warnings. (NOTE: If wet snow avalanche hazard exists due to warm, sunny weather, a much higher degree of safety can be achieved by plowing at night.)

WP observer plus HF provide warnings of renewed avalanche hazard during late spring due to late snowstorms or onset of heavy thaw periods.

If persistent cold weather delays spring slide cycle and snow pack stabilization, truck-transported and mounted 105 mm. recoilless rifle is used to fire on critical targets (especially Liberty Bell) to allow early plowing with minimum risk.

Implications

- 1) WP observer plays a key role in safe and early opening of highway.
- 2) ND observer is needed during winter for maximum safety and efficiency in Skagit Gorge.
- 3) No avalanche warning signs for individual paths are needed except in Skagit Gorge.

APPENDIX B

(from the Silverton Standard, Silverton, Colorado)

THE STANDARD OPINION

WITH ONLY SIX MEN

This past week we traveled the roads out of Silverton in both directions, toward Ouray to the north and Durango to the south. We saw a graphic display of this winter's accumulation of snow; heavy, high snow walls border the roads in many areas, showing that tons and tons of snow have had to be sliced away and pushed from the roadway. Occasionally there are slices through taller snow heaps, obvious remains of snowslides across the road that have had to be plowed through and pushed over the mountain sides.

We also noted the problems created by the warmer temperatures. Compounding the everyday problems of snow on the roads and the danger of snowslides, thawing ground on many of the banks above the roads has loosened, letting rock debris and boulders tumble onto the roadway.

On this latest trip over the roads, I marveled, as I do every time I pass along those roads, at the difficulties of road maintenance in these mountains.

I've heard others say, and there's no doubt in my mind, that we have one of the best highway crews in the state.

Tuffy Foster, senior highway maintenance man from Silverton, and his crew are responsible for the usual excellent condition of the local roads. The six men on the crew work 24 hours a day on three shifts. Tuffy started the 24-hour-a-day program when he came to Silverton five years ago. If someone had an accident in the middle of the night, he reasoned, they would have better chances of being found right away and less chance of freezing to death during the night, if crews were on the roads at all times. Now each shift makes at least one "round"--to the top of Molas Pass and then back over to the top of Red Mountain.

Foster is also the man responsible for the decisions on when and when not to shoot avalanche catch basins in attempts to control snowslides which could cross the highway. The artificial impetus often brings down (under more controlled conditions) a slide that presents potential hazard. Foster reported that this year they shot at more, but brought down fewer slides than ever. He also said there was considerably more snow this year than in the past two years.

It is truly amazing that six men, with a conglomeration of equipment, can do what they've done all winter around here. Bernard Boglino, Stanley Johnson and Johnny Cundiff work on the crew six months of the year, and Eddie Bellino, Leroy Foust and Foster work year-round. They all deserve thanks for a hard winter's work.

--Rox Duthie

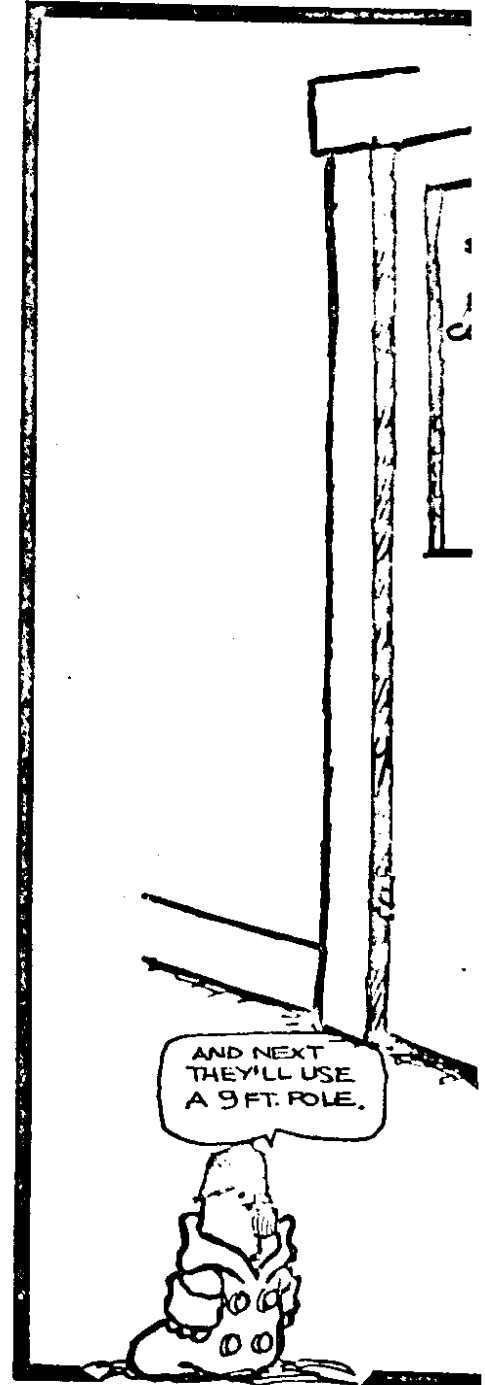

FROM THE

APPENDIX C

An Algorithm to Define Constraints on Use of Artillery

Fire for Avalanche Control and Application

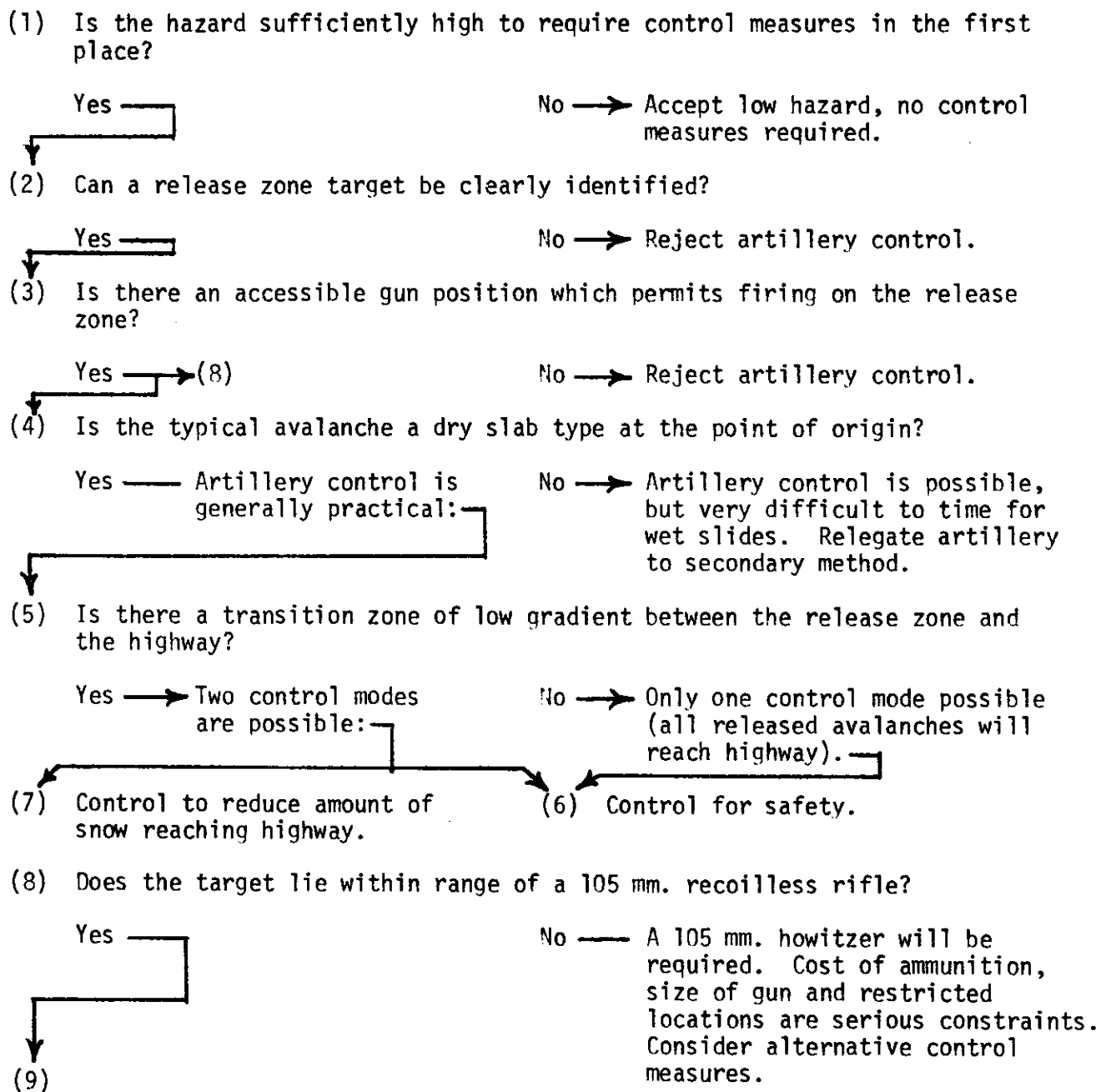

(9) Is a fixed mount (gun tower) practical?

Yes → Adopt tower design.

No → Gun must be fired from a truck
or snow cat (blind firing
difficult).

(10) Can gun be elevated to reach target when vehicle-mounted?

Yes → Adopt vehicle-mounted
gun for control.

No → Reject artillery control.

- Notes:
- A. Control mode (6) reduces options for timing of artillery fire. Control mode (7) allows early timing of artillery fire to bring down smaller slides which may often not reach the highway.
 - B. An avalanche path may meet these criteria for artillery control, but alternate methods such as snow sheds may be preferable. Operational and cost-effective factors will govern the decision.
 - C. This algorithm assumes direct fire on perceivable targets. In several instances indirect fire with a howitzer on hidden targets would be possible.

The artillery control algorithm is now applied to the avalanche paths listed in the North Cascades Highway Avalanche Atlas:

- PH-1 - artillery control rejected (ACR) at step 1
- PH-2 - ACR at step 1
- PH-3 - ACR at step 1
- PH-4 - ACR at step 1
- NH-1 - ACR at step 3
- NH-1a - ACR at step 1
- NH-2 - ACR at step 3
- NH-2a - ACR at step 2
- NH-3 - ACR at step 1
- NH-4 - ACR at step 3 (target too close to gun position -- high shrapnel hazard to gun crew.)
- NH-5 - ACR at step 4 and possibly step 8. (Artillery control is possible here.)
- NH-6 - Artillery control acceptable (ACA), adopt gun tower, control mode (6) only.
- NH-7 - ACR at step 1
- NH-8 - ACR at step 1 (and 3)
- NH-9 - ACR at step 3

- NH-10 - ACR at step 1
- RM-1 - ACR at step 1
- RM-2 - ACR at step 1
- RM-3 - ACR at step 1
- RM-4 - ACR at step 1
- RM-5 - ACR at step 3
- RM-6 - ACR at step 1
- RM-7a&b - ACR at step 1
- RM-8 - ACR at step 1 (pending field check)
- RM-9 - ACR at step 3 (pending field check)
- RM-10 - ACR at step 3 (pending field check)
- CM-1 - ACR at step 1
- CM-2 - ACR at step 1
- Beebe Mtn. - ACR at step 1
- LGC - ACR at step 1
- GC-1 through GC-15 - These avalanches reach the highway infrequently

(maximum of once a winter, most less frequent) and would be a significant hazard only for very high traffic densities.

Artillery control is possible on many of these paths, but the time and cost ordinarily would not be justified. During unusually bad avalanche conditions, control with a vehicle-mounted gun may be both desirable and possible on several of the Granite Creek paths (field check required).

In all cases, control option (7) is possible.

- RL-1,2,3,4 - ACR at step 1
- WM - ACA, adopt gun tower, control option (7) marginal.
- WS - ACA, adopt gun tower (same site as WM), option (6) only.
- WSE - ACA, adopt gun tower, option (6) only.
- HM - ACR at step 1 for normal winter, but ACA from vehicle-mounted gun under extreme hazard conditions.
- LB-5 - ACR at step 1 for normal winter, but ACA for extreme hazard conditions (LB tower site).
- LB-4 - ACA, adopt gun tower, option (7) marginal.
- LB-3 - ACA, adopt gun tower, option (6) only.
- LB-2 - ACA, " " " " " "
- LB-1 - ACA, " " " " " "
- SG - ACA, adopt gun tower, option (7) marginal.
- KA-6 - ACR at step 1
- KA-1 through KA-5 - do not at present affect highway, but could affect a relocation. All six KA paths are amenable to effective artillery control.

- VP - ACA, adopt vehicle-mounted gun, option (6) only.
- CR-1 through CR-11 - ACR at step 3. (For Cutthroat Ridge, a spur road to opposite side of Early Winters Creek would be needed to reach a suitable gun platform. But CR-3, 5, 7, 9, 11 are rated ACR at step 2 anyway, so this would offer only limited advantage.)
- DR-13 - ACA, adopt gun tower, option (7) available.
- DR-12 - ACA, adopt gun tower, option (7) available.
- DR-11&12 - ACR at step 1 (ACA from gun positions for other DR paths during exceptional hazard conditions).
- DR-9 - ACA, adopt gun tower, option (7) available.
- DR-8 - ACA, " " " " " "
- DR-7 - ACA, " " " " " "
- DR-6 - ACR at step 1
- DR-5 - ACA, adopt gun tower, option (7) available.
- DR-4 - ACA, " " " " " "
- DR-3 - ACR at step 1
- DR-2 - ACR at step 1
- DR-1 - ACR at step 1
- SS-5 - ACR at step 1
- SS-4 - ACR at step 1
- SS-3 - ACR at step 1
- SS-2 - ACR at step 1
- SS-1 - ACR at step 1

APPENDIX D

Blind Firing Adjustment Design

A recurring problem in the artillery control of avalanches on highways is the need to move a gun from one location to another and position it accurately at each location so it can be used for blind firing. This problem becomes acute on the North Cascades Highway because there are many widely-dispersed firing locations. The current solution (such as used at Stevens Pass) of moving a gun from one fixed gun tower to another will be undesirable because of the large amount of time required to mount and demount a gun at each of numerous gun towers.

The basic problem is to level and to position the gun accurately to within a fraction of an inch so that angles turned by the optical sight to a reference target (aiming stake) can be accurately reproduced each time the gun is fired blind. This is very difficult to do with the gun mounted on a truck, although such a mount would allow fast and flexible avalanche control work. We propose a simple solution to this problem based on the assumption that a truck can readily be positioned to within a foot or so in respect to benchmark imbedded in the highway surface. The aiming stake, mounted on a fixed steel pipe readily accessible from the highway, is then shifted with the aid of an indexing plate to correct for the last few inches of error in the gun position. The gun mount on the truck bed must have provision for rapid leveling prior to firing from each location, but this requires only a simple mechanical arrangement.

Details of the proposed scheme for blind-firing from a mobile vehicle are outlined in the two accompanying sketches.

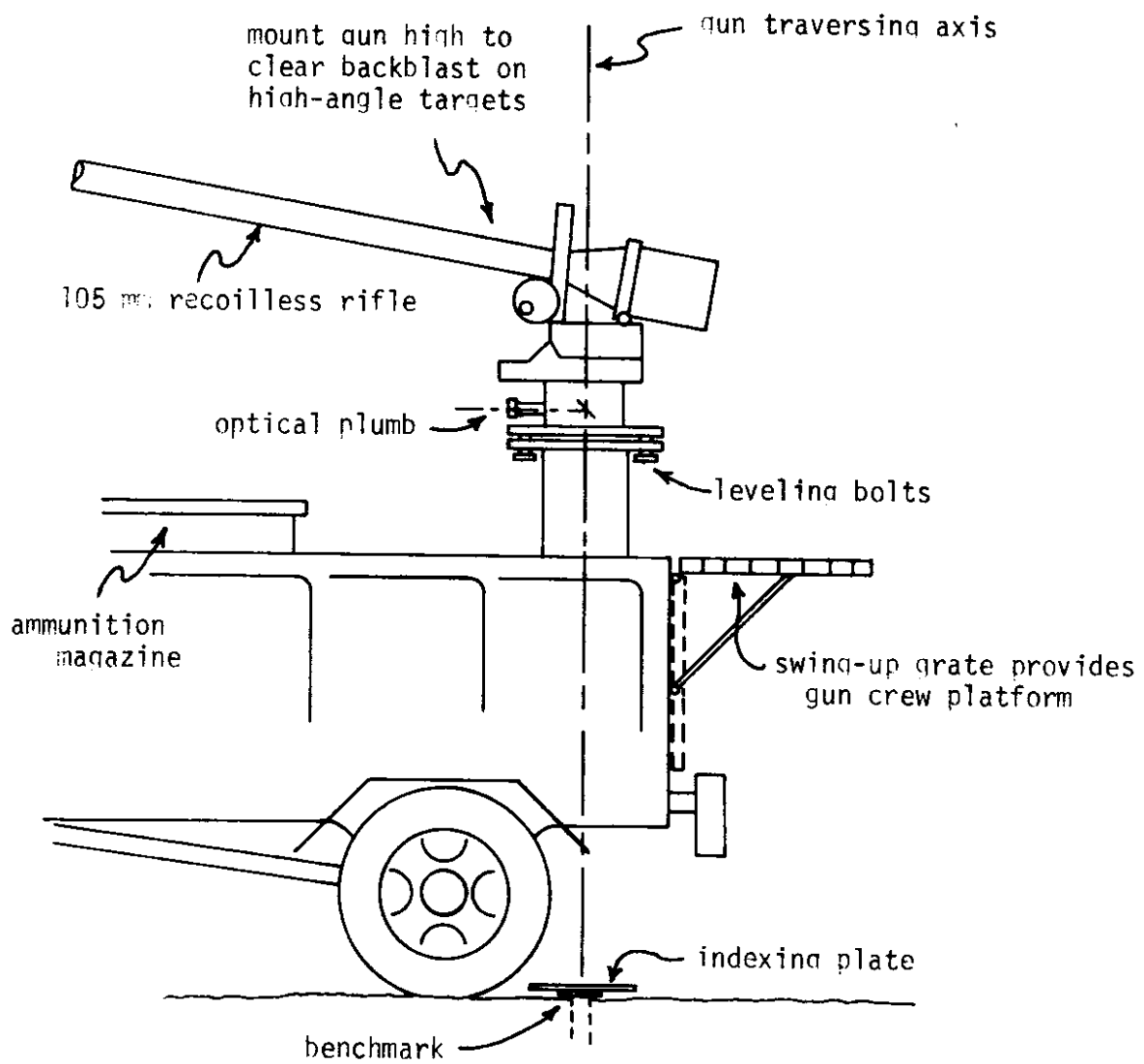

Figure 7

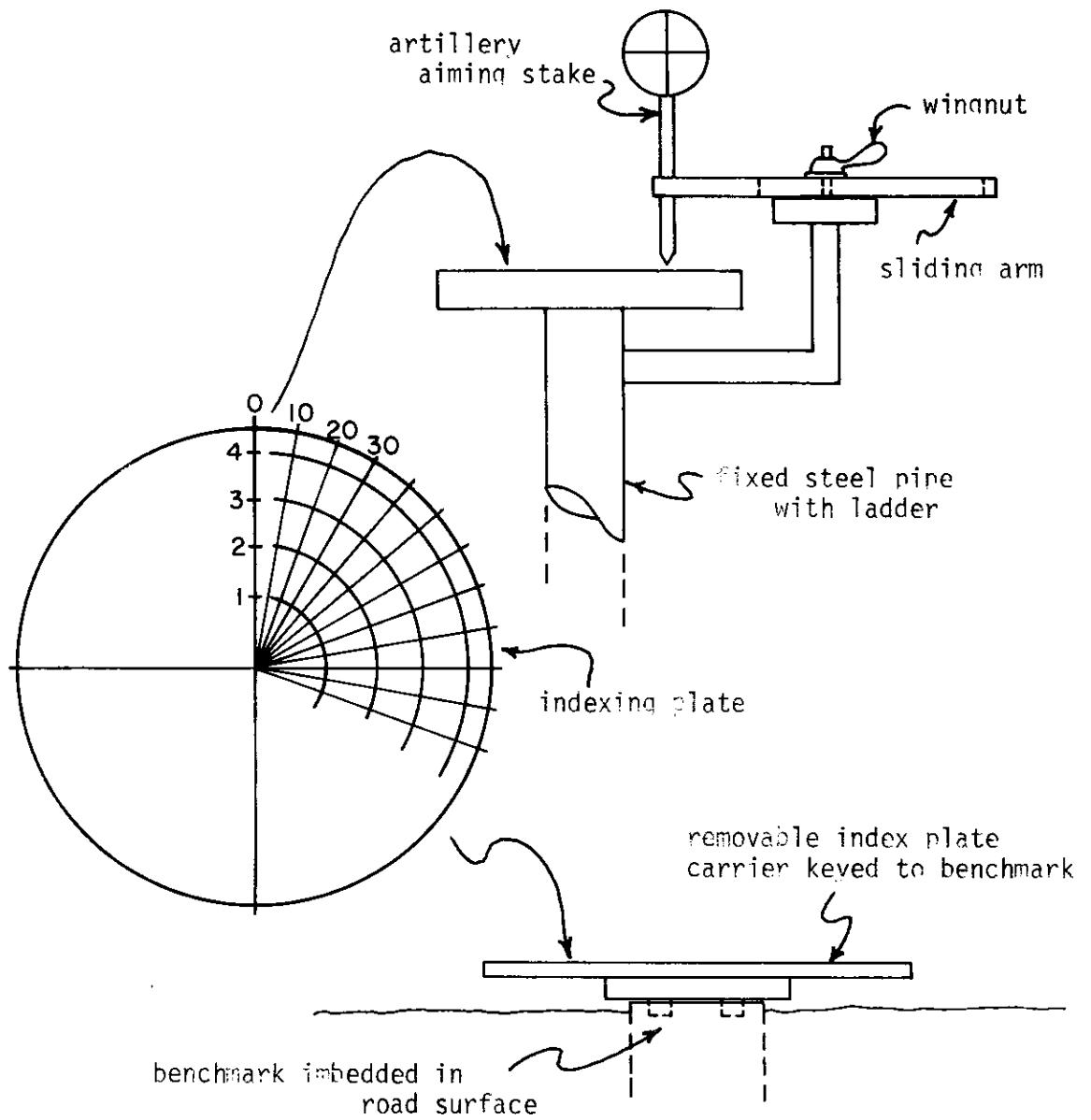

Figure 8

Each adjustable aiming stake is provided with a fixed indexing plate as shown. The gun truck carries a portable indexing plate identical to those at the aiming stakes. At each firing location, a benchmark is permanently imbedded in the highway, preferable at the centerline to facilitate positioning the truck. A keying system common to all benchmarks allows the portable indexing plate to be installed on a benchmark each time with unambiguous orientation. At each benchmark this orientation must correspond to that of the adjacent aiming stake indexing plate.

Assuming a two-man artillery crew consisting of gunner and assistant gunner, one of whom also drives the truck, the proposed scheme would work like this when the gun truck arrives at a firing location:

- 1) Snow is cleared by hand from the benchmark and the portable indexing plate is installed on it.
- 2) Gunner backs the rear of the truck over the benchmark, guided by hand signals from the assistant gunner. A marker on the truck chassis aids in positioning the gun traversing axis close to the benchmark, but this axis need be no closer to the benchmark than the radius of the indexing plate.
- 3) Gunner levels the gun with a wrench and bubble level while assistant gunner ascends the aiming stake pipe.
- 4) Gunner reads off indexing plate coordinates appearing at cross-hairs of the optical plumb (illumination will be needed at night).
- 5) Assistant gunner sets and locks aiming stake to these same coordinates on the aiming stake indexing plate.
- 6) Gun is now ready for blind firing and the normal firing checklist is followed from this point on.

APPENDIX E

Scenario for Winter Storm Sequence on Open Winter

Highway Under Artillery Control*

Winter Storm and Avalanche Sequence, Jan 18 - 21, 197X

January 18 - early AM:

WP and ND observers report highway clear, snow cover poorly consolidated, with avalanching in the Liberty Bell/Cutthroat Ridge area possible any time 6" or more snow falls with wind. A clear night is followed by increasing overcast moving from NW. Network hazard forecaster (HF) issues warning of cold front off British Columbia coast due to bring precipitation to Cascade Mountains by evening.

Maintenance foreman dispatches normal sanding patrols on North Cascade Highway and alerts snow camps to impending storm.

(Note - assumes single foreman..could be 2..but have to be coordinated)

Jan 18 - 1200 hrs:

Onset of precipitation along Washington coast. HF issues network warning that snowfall may begin earlier than previously predicted. Intensity of cold front still uncertain. Maintenance crews and NCH observers alerted.

- 1500 hrs:

Pre-frontal precipitation reported from Skagit Gorge - light rain with snow level around 2000 ft.

Light snowfall begins along Ruby Mountain shortly thereafter and rapidly progresses eastward over WP. Advisory warning from avalanche network (HF)

*Corresponds to Option 4a in 1971 Report, with some blind firing added.

indicates heavy snowfall developing with frontal passage farther west (Mt. Baker reports snowfall rates over 4"/hr).

-1600 hrs:

Maintenance foreman orders yellow alert for NCH. Notices are sent by established mechanism to Highway Patrol, Department Headquarters, press and radio. Automatic signs at Sedro Wooley, Marblemount, Twisp, Mazama, come on to warn travelers that NCH may be closed on short notice. Chain control imposed at Mazama and Thunder Arm.

- 1730 hrs:

ND observer reports abrupt temperature drop and onset of intense snowfall in Skagit Gorge. Chain control extended to Newhalem, full road patrol for entire NCH by plows and sanders initiated.

-2000 hrs:

WP observer reports cold front has passed WP with onset of intense snowfall and gusty winds. Visibility is near zero over Rainy and Washington Passes. WP observer consults with HF and issues first avalanche alert, with possibility of Cutthroat Ridge slides running to highway by midnight.

(The foreman now confronts a situation demanding immediate action. The snowfall has developed faster and heavier than the forecast promised in the morning. His observers and the highway avalanche network have kept him abreast of the changing weather and snow situation but his leeway ahead of avalanche hazard has diminished very rapidly.)

Radio reports from operating plows identify at least six vehicles in transit over the highway, with difficulty for the plows to keep ahead of drifting snow over the passes.

- 2015 hrs:

Foreman orders Red Alert for NCH with closure posted for 2200 hrs. (This means NCH must be clear of traffic by 2200 hrs.) Highway is immediately posted closed at Newhalem and Mazama by 2030 hrs., with appropriate signals to automatic signs farther east and west. Highway sweep begins east and westbound.

- 2055 hrs:

Radio report from plow: Westbound passenger car is off road and stuck in snowbank 1/2 mile east of State Creek bridge. Visibility near zero in blizzard conditions. Foreman orders plow to pull car back on road and convoy it over Rainy Pass, to be picked up by westbound sweep vehicle.

- 2100 hrs:

Radio report from plow westbound down Granite Creek: Semi-trailer stalled eastbound with broken chain just above landslide site.

- 2115 hrs:

Radio report from same plow: Sluffs have run from LGC cutbanks big enough to block traffic. Snow is soft and can be cleared by push plow, which is now being done.

- 2130 hrs:

WP observer reports wind velocities and snow crystal types favorable for soft slab formation. There is imminent danger of avalanche release along Cut-throat Ridge.

- 2140 hrs:

East- and west-bound sweep vehicles meet at Swamp Creek. Eastbound vehicle has been delayed by sluffs at LGC, west-bound by blizzard conditions over the passes. Passenger car pulled out of snow bank by plow appears at Swamp Creek west-bound and stops to inquire about road conditions.

Radio coordination between highway sweep vehicles and gates shows all traffic has cleared highway except stalled semi-trailer, passenger car at Swamp Creek and one pick-up camper seen headed east-bound under Liberty Bell by west-bound sweep vehicle.

- 2200 hrs:

Both sweep vehicles depart from Swamp Creek, with passenger car in convoy west-bound.

- 2225 hrs:

West-bound sweep vehicle reports semi-trailer still stalled in lower Granite Creek and requests instructions.

- 2228 hrs:

Plow working in Skagit Gorge reports NH-4 has slid into road in large volume and requests assistance from a rotary plow.

- 2235 hrs:

HF issues general warning to highway network: Intense precipitation is expected to continue through the night. A general condition of high avalanche hazard exists on NCH.

- 2239 hrs:

Plow working west from Pine Creek reports CR-2 has run to highway and will require a rotary plow to clear. Radio check locates east-bound sweep vehicle just east of WP.

(At this point the foreman finds his safety lead time has vanished and problems are multiplying like rabbits.)

- 2244 hrs:

Foreman confers by telephone with HF. Avalanche conditions are rapidly going to get worse during the night.

- 2249 hrs:

Foreman orders plows and sanders withdrawn from NCH east of Rainy Pass and in Skagit Gorge. West-bound sweep vehicle is directed to return to Swamp Creek with semi-trailer driver and passenger car for the night. East-bound sweep vehicle ordered to sand pile site at WP.

- 2310 hrs:

Gate control at Mazama reports pick-up camper has cleared east-bound. NCH secured until end of storm. Plows continue to work between Diablo and Rainy Pass.

January 19

- 0600 hrs:

WP observers report 14" new snow, storm continues. ND observer reports 8" new snow at Diablo, storm continues.

- 0700 hrs:

HF issues weather and avalanche forecast. Storm is expected to end during the day. High avalanche hazard will persist on NCH until after snowfall ends. Unstable snow responsive to artillery control is expected to persist for another 24 hrs.

- 0835 hrs:

Snow plow reports RM-10 has slid in medium volume across highway sometime in past hour. Rotary plow will be required to clear.

- 0930 hrs:

WP observer reports snowfall diminishing. ND observer reports storm almost ended in Skagit Gorge. Foreman confers with HF and orders blind firing on SG and LB paths from Overlook gun, to be executed by WP observer and driver of

sweep vehicle stuck at WP. Rotary plow dispatched to Skagit Gorge to plow slides where necessary as soon as visibility permits ND observer to stand avalanche watch on lower part of paths.

- 1030 hrs:

Snowfall easing off rapidly at Swamp Creek and over Passes (WP observer).

- 1200 hrs:

Foreman and HF confer. Agree to dispatch rotary from Swamp Creek to begin clearing RM-10, since storm is rapidly ending and not much hazard en route.

- 1300 hrs:

Storm has ended. WP observer reports: Artillery fire completed, LB-1 & 2 had already slid naturally, LB-3 released by fire, all three across road, no response from SG. Most CR paths have slid into road. Snowcat recon to Rainy Pass shows no avalanche activity on Whistler Mountain but several small slides into road from Whistler Shoulder (WS). Foreman orders rotary from Pine Creek to start clearing Cutthroat Ridge.

- 1330 hrs:

Rotary plow in Gorge reports several small sluffs cleared and another 30 min. work left on NH-4.

- 1430 hrs:

HF calls NCH foreman. A warm front is rapidly approaching the coast and is expected to reach the North Cascades by midnight. Avalanche forecast for NCH: Snow stability is currently increasing after end of storm, and chances of further natural releases are slight, but onset of rain and/or wet snow in release zones is apt to trigger a new cycle of avalanches, especially on those paths which have not yet slid.

HF recommends immediate artillery fire on Delancey Ridge paths and Whistler Mountain to stabilize these ahead of arriving warm front. No control is recommended for Granite Creek and is not possible for Skagit Gorge or Ruby Mountain. Foreman orders gun trucks from Pine Creek to Delancey Ridge and from Swamp Creek to Whistler Mountain.

- 1500 hrs:

Plows report: Gorge rotary has reached Diablo, no other slides encountered. Rotary at RM-10 reports slow work due to debris in slide, estimates another 2 - 3 hours work. CR rotary has reached CR-5, progress is good.

Foreman dispatches Gorge rotary to RM-10 to begin work on this slide from other side. Swamp Creek rotary is shifted from RM-10 to Whistler Shoulder and to stand by during artillery fire on Whistler Mountain.

- 1540 hrs:

Gun truck at Whistler Mountain reports only sluffing from artillery fire and is waiting for arrival of rotary plow at Whistler Shoulder.

- 1630 hrs:

Rotary plows report: Whistler Shoulder cleared. Work begins on west side of RM-10. Good progress on CR with plow at CR-10.

Foreman dispatched Swamp Creek rotary from WS to LB area. Daylight is fading fast and forerunning clouds of warm front are developing an overcast.

- 1745 hrs:

East-side gun truck reports following results from artillery fire on Delancey Ridge:

DR-4, 12 & 13 slid to transition
DR-5 through 11, sluffing only
SS-2 slid to Early Winters Creek with large dust cloud.
No avalanches reached highway.

- 1810 hrs:

Rotary reports from LB-3: Slide snow has filled highway completely and stands 40 ft. deep on uphill side. Bulldozer will be needed. Inspection on foot shows that LB-1 & 2 are similar but with smaller depths of snow on highway.

- 1845 hrs:

Pine Creek rotary reports clearing completed under Cutthroat Ridge with highway passable for narrow two lanes. Now plowing LB-3 on lower leg of hairpin curve.

- 1900 hrs:

Foreman calls HF for check on weather. Warm front still expected some time after midnight, precipitation probably fairly heavy. An avalanche cycle can be expected with possible heavy sliding in Skagit Gorge.

Foreman elects to call off plowing operations at WP for the night and wait until after warm front precipitation to commit bulldozer to LB slides. Rotary at RM-10 reports clearing nearly completed. Rotary at LB-3 lower leg instructed to complete clearing (estimated 2 hours) and return to Pine Creek.

(At this point NCH is plowed clear and passable to traffic except for LB slides. Some widening by further rotary work required under Cutthroat Ridge. Highway remains closed, except open for local traffic Newhalem-Diablo.)

- 2300 hrs:

Highway avalanche network alert: Overrunning warm front has reached southern Cascades. 1 - 2 hours of wet snowfall precedes onset of rain up to 6000 ft.

January 20

- 0300 hrs:

Avalanche network alert: Warm front reached Stevens Pass at 0250 hrs. Several avalanches have fallen on Paradise Highway and at Crystal Mountain. Alpentel reports high winds and rain at ridgetops.

- 0510 hrs:

ND observer reports Sourdough Mountain telemeter shows air temperature starting to rise rapidly. Rain is falling in Skagit Gorge. Foreman orders Skagit Gorge closed to local traffic.

- 0545 hrs:

HF reports to NCH foreman: Warm front is occluding as it moves N and E. Several hours of post-frontal snowfall can be expected from Rainy Pass east. WP observer confirms that wet, heavy snow is beginning to fall. There is some possibility of Granite Creek avalanches running to highway. Foreman orders suspension of plowing to continue until storm and avalanche situation matures.

- 0800 hrs:

WP observer reports intense snowfall, moderately high winds, temperature 29 degrees F.

- 0915 hrs:

ND observer reports rain continues in Gorge, with low clouds and poor visibility. Several avalanches have been heard from Newhalem but locations are unknown.

- 1400 hrs:

Some breaks appearing in storm, snowfall level drops to 2000' in Gorge, WP observer reports snowfall intensity diminishing.

Foreman dispatches plows to begin work and check avalanche occurrence.

- by 1530 hrs:

Following avalanches are reported:

DR-9 into highway - 300' wide, maximum 8' deep.

Plow-out under CR has largely been filled in by a new cycle of small avalanches.

SG has run in volume and covers hairpin curve to 10' deep for 250'.

GC-9 onto highway, 20' deep, 75' wide.

RM-5 almost to highway.

RM-9 - 100' wide, up to 15' deep on highway.

NH-1 - 60' wide, 20' deep on highway.

NH-5 - 150' wide, 30' deep on highway

NH-8 - 80' wide, 15' deep on highway.

- 1600 hrs:

Observers report snowfall ended in all areas. HF reports to avalanche network: Clearing with falling temperatures expected during the night. No more precipitation expected for next 36 hours. Avalanche hazard should diminish rapidly in all areas as wet snow begins to freeze.

- 1630 hrs:

Foreman orders full-scale clearing operations to begin on all avalanches which reached NCH and to continue through night.

(At this point bulldozers are at Newhalem, Swamp Creek, Pine Creek and Mazama. Rotaries are at Diablo, Swamp Creek and Pine Creek. The problem is to dispose this equipment for optimum efficiency. NH & LB slides and GC-9 and RM-9 will require bulldozers. LB slides will take longest to clear.)

Newhalem bulldozer and rotary at Diablo are dispatched to Skagit Gorge. Swamp Creek equipment is set to work on GC-9, to be followed by RM-9. Pine Creek equipment set to work on DR-9, to be followed by CR.

- 2200 hrs:

Plows report: NH-1 cleared by bulldozer, now working on NH-5. Rotary making slow progress on NH-8, need help from dozer.

GC-9 has been cleared, work in progress on RM-9.

DR-9 has been cleared, equipment now at CR-3 and reports CR avalanching has been light but just enough to fill up previously cleared rotary cut.

Foreman dispatches large end-loader from (Diablo?, Sedro-Wooley?) to assist with NH slides.

January 21

- 0200 hrs:

RM-9 cleared, bulldozer and rotary dispatched to WP to begin work on LB slides from the west.

- 0300 hrs:

CR slides and small VP reported cleared with double rotary cut. Instructions requested: Should Pine Creek bulldozer start pushing over downhill side of CR rotary cut to avoid catching the next round of slides, or proceed to LB-1? Foreman orders continued clearing of CR, with rotary to proceed to LB-1.

- 0500 hrs:

Swamp Creek bulldozer reaches LB-3, with relief driver taking over.

- 0930 hrs:

CR bulldozer reports slow progress with snowbank removal. This is mostly old avalanche snow, set up hard. Equipment at LB slides also finding slow going due to depth and steepness of avalanche snow on road. CR bulldozer shifted to LB. All of NCH now cleared of snow except LB slides.

- 1400 hrs:

LB plowing nearly finished and another hour of work reported left. Foreman orders NCH open to traffic --- signs revised and gates open. Highway has been continuously closed for 64 hours.

- 1500 hrs:

Last of slide debris cleared from LB-3 as traffic reaches this area. Normal traffic flow resumes with routine maintenance and condition Green for NCH.

Both bulldozers from LB shifted to continue clearing road shoulder under CR.

- 2000 hrs:

Avalanche network forecast: Front approaching Washington coast is expected to bring snowfall to North Cascades by early morning.

January 22

- 0600 hrs:

WP observer reports snowfall since 0430, wind is from SSW gusting to 25 mph on ridges. HF issues NCH alert: Soft slab avalanches can be expected to run on LB and CR paths by noon if storm persists.

Implications

- 1) Chain control sites are needed at Mazama, Thunder Arm, Newhalem (Marblemount?)
- 2) Gates east and west must be manned after closure to keep new traffic out but let traffic already underway on NCH through.
- 3) Continual radio communication is needed between sweep vehicles and gates.
- 4) More than 2 hrs. will be required to complete sweep under blizzard conditions.
- 5) Random traffic flow during hazard periods and prior to impending closure can better be handled if it is logged in and out at checkpoints (know where all vehicles are and whether any have failed to clear gates with closure).
- 6) Good radio net with radios in all vehicles, including plows, is essential.
- 7) At least three rotary plows are needed, stationed at Newhalem, Swamp Creek and Pine Creek. Ditto bulldozers.
- 8) A unified command post under a single highway foreman is essential. It is difficult to see how this operation could be handled with a divided command. The foreman needs a large map of the highway showing all avalanche paths, with a plastic overlay on which current avalanche occurrences and status of clearing operations can be recorded.

