

Bridge Seismic Retrofit Planning Program

WA-RD 217.1

Final Report
December 1991



Washington State Department of Transportation
Planning, Research and Public Transportation Division

in cooperation with the
United States Department of Transportation
Federal Highway Administration

TECHNICAL REPORT STANDARD TITLE PAGE

1. REPORT NO. WA-RD 217.1	2. GOVERNMENT ACCESSION NO.	3. RECIPIENT'S CATALOG NO.
4. TITLE AND SUBTITLE BRIDGE SEISMIC RETROFIT PLANNING PROGRAM		5. REPORT DATE December 1991
		6. PERFORMING ORGANIZATION CODE
7. AUTHOR(S) Khossrow Babaei and Neil M. Hawkins		8. PERFORMING ORGANIZATION REPORT NO.
		10. WORK UNIT NO.
9. PERFORMING ORGANIZATION NAME AND ADDRESS Washington State Transportation Center (TRAC) University of Washington, JE-10 The Corbet Building, Suite 204; 4507 University Way N.E. Seattle, Washington 98105		11. CONTRACT OR GRANT NO. GC8719, Task 22
		13. TYPE OF REPORT AND PERIOD COVERED Final report
12. SPONSORING AGENCY NAME AND ADDRESS Washington State Department of Transportation Transportation Building, KF-01 Olympia, Washington 98504		14. SPONSORING AGENCY CODE
		15. SUPPLEMENTARY NOTES This study was conducted in cooperation with the U.S. Department of Transportation, Federal Highway Administration.
16. ABSTRACT <p style="margin-left: 40px;"> This report documents a study that determined the effectiveness and cost of both previously used and proposed bridge superstructure seismic retrofit methods, including longitudinal joint restraining, transverse bearing restraining, bearing seat extension, replacement of vulnerable bearings with conventional bearings, and replacement with base isolation bearings. In addition, a procedure was developed for systematically prioritizing the state's bridges for seismic retrofitting on the basis of their importance as lifelines and their vulnerability to collapse. </p>		
17. KEY WORDS bridge, earthquake, retrofitting, superstructure, prioritizing, cost		18. DISTRIBUTION STATEMENT No restrictions. This document is available to the public through the National Technical Information Service, Springfield, VA 22616
19. SECURITY CLASSIF. (of this report) None	20. SECURITY CLASSIF. (of this page) None	21. NO. OF PAGES 91
22. PRICE		

Final Report
Research Project GC 8719, Task 22
Bridge Seismic Retrofit Planning Program

**BRIDGE SEISMIC RETROFIT PLANNING
PROGRAM**

by

Khossrow Babaei
Consultant

Neil M. Hawkins
Head of Civil Engineering
University of Illinois at
Urbana-Champaign

Washington State Transportation Center (TRAC)
University of Washington, JE-10
The Corbet Building, Suite 204
4507 University Way N.E.
Seattle, Washington 98105

Washington State Department of Transportation
Technical Monitor
Ed Henley
Bridge Technology Development Engineer

Prepared for

Washington State Transportation Commission
Department of Transportation
and in cooperation with
U.S. Department of Transportation
Federal Highway Administration

December 1991

DISCLAIMER

The contents of this report reflect the views of the authors, who are responsible for the facts and the accuracy of the data presented herein. The contents do not necessarily reflect the official views or policies of the Washington State Transportation Commission, Department of Transportation, or the Federal Highway Administration. This report does not constitute a standard, specification, or regulation.

TABLE OF CONTENTS

Section	Page
Summary	v
Introduction	v
Research Approach	v
Conclusions	vi
Recommendations	vii
Chapter 1: Introduction.....	1
Objective	2
Research Approach	2
Chapter 2: Effectiveness of Retrofit Measures.....	5
Superstructure Restraining Program in California: History and Performance	5
Joint Longitudinal Restrainers	8
Transverse Bearing Restrainers.....	21
Bearing Seat Extensions.....	23
Replacement of Vulnerable Bearings with Conventional Bearings.....	25
Base Isolation Bearings.....	26
Chapter 3: Cost Estimates of Retrofit Measures.....	35
Retrofit Item Prices	35
Longitudinal Restrainers (Pier and Abutment Joints).....	36
Longitudinal Restrainers (Mid-Span Hinges).....	39
Transverse Bearing Restrainers (Mid-Span Hinges).....	41
Retrofitting Seismically Vulnerable Bearings.....	42
Base Isolation	43
Chapter 4: Development of Index for Retrofit Prioritization	45
Form of the Model.....	45
Range of Criticality Factor "A" and Priority Index "I"	49
Probabilistic Estimate of Peak Acceleration Based on the Remaining Service Life of Structure	50
Acknowledgment.....	53
References	55
Appendix A: Preliminary Form of the Bridge Seismic Retrofit Prioritization Model.....	A-1
Appendix B: Panel's Review Comments on the Preliminary Form of the Bridge Seismic Retrofit Prioritization Model	B-1

LIST OF FIGURES

Figure		Page
1.	Prestressed I-Beam, and T-Beam, to Pier Cap Connection.....	10
2.	Steel Girder to Pier Cap Connection.....	11
3.	Prestressed I-Beam, and T-Beam, to Abutment Wall Connection....	12
4.	Steel Girder to Abutment Wall Connection.....	13
5.	Box-girder Mid-Span Hinge Longitudinal and Transverse Restrainers.....	16
6.	T-Beam Mid-Span Hinge Longitudinal and Transverse Restrainers.....	18
7.	Desirable Details for Insuring a Smooth Build-Up of the Restrainer Force in the Event of a Major Earthquake.....	20
8.	Steel Girder Mid-Span Hinge Longitudinal Restrainer.....	20
9.	Steel Girder Mid-Span Hinge Transverse Restrainer.....	24
10.	Bearing Seat Extension.....	25
11.	Replacement of Vulnerable Steel Expansion Bearing.....	27
12.	Modification of Vulnerable Steel Fixed Bearing.....	28
13.	Lead-Rubber Base Isolation Bearing.....	31
14.	Velocity-Related Acceleration Coefficient Map of Washington.....	48

SUMMARY

INTRODUCTION

The state of Washington, particularly in the Puget Sound area, is an active seismic zone. The earthquake of 1949, which occurred near Olympia, and the earthquake of 1965, which occurred between Seattle and Tacoma, are typical of the damaging earthquakes likely in the state. However, recent research suggests that there is a potential in Washington for an earthquake of significantly greater magnitude than the 1949 and 1965 earthquakes. Furthermore, the 1971 San Fernando and the 1989 Loma Prieta earthquakes in California demonstrated that bridges designed according to the AASHTO specifications prevailing in 1971 are vulnerable to seismic activities.

In 1983, AASHTO published new guidelines for the seismic design of bridges that embodied several concepts significantly different from those in previous guidelines. Currently, WSDOT designs its new bridges to those 1983 AASHTO guidelines. However, a study by the WSDOT Bridge and Structures Office showed that of the 1,562 state bridges (approximately half of the state's 3,100 bridges) located in the higher seismic risk zone of western Washington, the majority were designed before the new AASHTO seismic guidelines were established. Therefore, seismic retrofitting priorities and guidelines for bridges in Washington need to be defined. WSDOT initiated this project to evaluate the effectiveness and cost of possible bridge superstructure seismic retrofit measures and to develop a procedure that could be used to prioritize the superstructures of existing state bridges for seismic retrofitting.

RESEARCH APPROACH

The first task in the project involved determining the effectiveness of both previously used and proposed bridge superstructure seismic retrofit methods, by means of a literature search and contact with agencies knowledgeable in seismic retrofitting. The second task was to estimate the cost of the seismic retrofit measures considered in Task 1,

and the third task was to develop a procedure for systematically prioritizing the state's bridges for seismic retrofitting on the basis of their importance as lifelines and their vulnerability to collapse.

CONCLUSIONS

Comparison of the magnitude of damage to the bridges in the 1971 San Fernando earthquake and damage to the bridges in the 1989 Loma Prieta earthquake in California showed that the overall performance of bridges was better in the Loma Prieta earthquake. This better performance is attributable to California's superstructure retrofitting program, which started after the 1971 San Fernando earthquake. However, it is difficult to say how the bridge structures, especially substructures, would have performed if the Loma Prieta earthquake had had a higher magnitude, had shaken the ground longer, had produced different ground motion characteristics, or had been accompanied by a sizeable aftershock.

An effective bridge seismic retrofitting program should consider both superstructure and substructure retrofitting, since procedures that retrofit only the superstructure may lead to overloading and failure of foundation or piers. However, only recommendations on the effectiveness of various superstructure retrofit measures are given in this report.

Further research to develop practical and economical methods of column and foundation retrofitting is definitely warranted.

This study developed a mathematical model to systematically prioritize bridges for retrofitting. Further refinements to the model may be warranted as more information becomes available on the factors that determine the importance of a bridge as a lifeline and the factors that determine its seismic vulnerability.

RECOMMENDATIONS

An effective bridge seismic retrofitting program should consider both superstructure and substructure retrofitting. Further research to develop practical and economical methods of column and foundation retrofitting is definitely warranted.

Capacity/demand ratios, calculated according to the procedures outlined in Federal Highway Administration Report No. FHWA/RD-83-007 titled "Seismic Retrofitting Guidelines for Highway Bridges," indicate the reduced load levels at which the superstructure or substructure may fail. The use of capacity/demand ratios to determine the degree of superstructure and substructure seismic vulnerability is recommended. If substructure retrofitting of a vulnerable bridge is not technically and economically feasible, its superstructure retrofitting is justified when the capacity/demand ratio of the retrofitted structure is larger than the capacity/demand ratio of the existing structure. The capacity/demand ratio of a bridge should be the smaller of the superstructure and substructure capacity/demand ratios. Otherwise, superstructure retrofitting without substructure retrofitting may increase the seismic vulnerability of the bridge.

Recommendations on the effectiveness of various superstructure retrofit measures are given in Chapter 2. The superstructure retrofit measures involve longitudinal joint restrainers, transverse bearing restrainers, bearing seat extension, replacement of vulnerable bearings with conventional bearings, and replacement with base isolation bearings.

Use of the mathematical model developed in Chapter 4 to systematically prioritize bridges for retrofitting, based on their importance as lifelines and their seismic vulnerability, is justified on the basis of existing knowledge. However, further refinements to the model may be warranted as more information becomes available on the factors that determine the importance of a bridge as a lifeline within the community, and the factors affecting a bridge's vulnerability to certain earthquake ground motion characteristics.

CHAPTER 1

INTRODUCTION

The state of Washington, particularly in the Puget Sound area, is an active seismic zone. The earthquake of 1949, which occurred near Olympia, and the earthquake of 1965, which occurred between Seattle and Tacoma, are typical of damaging earthquakes likely in the state. The 1965 earthquake, for example, was a magnitude 6.5 event with an estimated focal depth of 35 miles. As a result, its damage to structures was minimal. However, recent research has demonstrated that there has been and is a potential in Washington for earthquakes of much greater magnitude and significantly shallower focal depth than the 1965 earthquake. Furthermore, the 1971 San Fernando earthquake in California demonstrated that bridges designed to the AASHTO specifications prevailing in 1971 were vulnerable to seismic activities. In 1983 AASHTO published new guidelines for the seismic design of bridges significantly different from previous guidelines. Currently, WSDOT designs its new bridges to those 1983 AASHTO guidelines. However, a study by the WSDOT Bridge and Structures Office showed that of the 1,562 state bridges (approximately half of the state's 3,100 bridges) located in the higher seismic risk zone of western Washington, the majority were designed before the new AASHTO seismic guidelines were established. Therefore, seismic retrofitting priorities and guidelines for bridges in Washington need to be defined.

Seismic retrofitting of bridges has been customary in the U.S. only since the 1970s, when, after the 1971 San Fernando earthquake, the California Department of Transportation initiated a major retrofitting program. The initial goal of the California program was to retrofit bridge superstructures by tying superstructures to substructures at bearing supports and by tying superstructures together at hinges to prevent spans from separating at hinges or falling off their bearing supports. In the 1971 San Fernando earthquake there were two primary modes of failure. In the first mode, joints opened up and allowed collapse of the superstructures. The second mode was a substructure failure

caused by column deficiencies. Those deficiencies usually involved inadequate detailing of the reinforcing steel in columns, such as insufficient amounts of confinement and shear reinforcement, unsatisfactory splice location for main reinforcement, and inadequate end anchorage of the main reinforcement into the foundation or superstructure. Those deficiencies resulted in the failure of the columns, rather than the formation of the plastic hinges at the ends of the columns as needed for a ductile energy absorbing system.

An effective bridge seismic retrofitting program should consider both superstructure and substructure retrofitting. However, bridge superstructures are generally more vulnerable to collapse in the event of lower levels of ground motion. Also, superstructure retrofitting is relatively simple and inexpensive, while substructure retrofitting requires careful consideration of both loading and resistance. Thus, the prevailing philosophy of most engineers is that, in the presence of budget constraints, it is more effective, both in terms of economics and life safety, to retrofit superstructures of a large number of bridges rather than to complete, for the same cost, the comprehensive retrofitting of a small number of bridges.

OBJECTIVE

WSDOT initiated this project with the objective of evaluating the effectiveness and cost of bridge superstructure seismic retrofit measures and the development of a procedure that could be used to prioritize state bridges for seismic retrofitting on the basis of their importance and vulnerability.

RESEARCH APPROACH

The first task in the project was to determine the effectiveness of both previously used and proposed superstructure seismic retrofitting methods, through a literature search and contact with agencies knowledgeable in seismic retrofitting. Retrofitting methods explored were longitudinal joint restraining, transverse bearing restraining, bearing seat extension, replacement of vulnerable bearings, and replacement with base isolation

bearings. The second task of the project was to estimate the cost of the seismic retrofit measures considered in Task 1 on the basis of the basic cost items. Finally the third task was to develop a procedure to systematically prioritize state bridges for seismic retrofitting on the basis of their importance as lifelines and their vulnerability to collapse. The product of Task 3 was a priority index, the realism of which was reviewed by a panel of four experts. The priority index was subsequently tested and calibrated by the WSDOT Bridge and Structures Office.

CHAPTER 2

EFFECTIVENESS OF RETROFIT MEASURES

This chapter presents this study's findings regarding the effectiveness of bridge superstructure seismic retrofit measures, both practiced and proposed, in the United States and abroad. Those measures are longitudinal joint restrainers, transverse bearing restrainers, bearing seat extension, replacement of vulnerable bearings, and base isolation bearings. The main purpose of using those retrofit measures is to prevent loss of support at the bearings and consequent collapse of the superstructure. In the case of base isolation, the retrofit measure is also intended to minimize the seismic loads transferred to the substructure.

SUPERSTRUCTURE RESTRAINING PROGRAM IN CALIFORNIA: HISTORY AND PERFORMANCE

The California Department of Transportation's seismic retrofit program started after the 1971 San Fernando earthquake, an earthquake with a 6.4 magnitude. (1) Approximately 62 bridges suffered damage varying from cracking and spalling to total collapse in that earthquake. About 25 percent of the 62 bridges sustained severe damage, including seven that collapsed either totally or partially. (2) In many cases joints opened up and allowed collapse of the spans. The peak ground acceleration was recorded as 0.55g at Upper San Fernando Dam, about 6 miles from the epicenter (3), and as 0.25g at a Holiday Inn, 13 miles from the epicenter. (2) The bridges that collapsed were generally located about 9 miles from the epicenter. Thus, a rough estimate of the peak ground acceleration at the location of the bridges that collapsed is 0.40g.

After the San Fernando earthquake, an investigation by the California Department of Transportation found that of about 12,500 state bridges in California, approximately 10 percent were in need of seismic retrofitting. The retrofit program was begun modestly in 1971. Fourteen years later it developed into a \$53-million program for improvement of the seismic resistance of about 1,250 bridges. The initial goal of the California retrofit program

was to tie superstructures to substructures at bearing supports and to tie superstructures together at hinges to prevent spans from separating at hinges or falling off their bearing supports. Measures included cable or rod hinge restrainers, concrete-filled pipes inserted in cored holes through expansion joints, concrete shear blocks cast and doweled to supports, and structural steel restraining elements connected to bridge members.

The California bridges were subjected to several major earthquakes after the San Fernando earthquake and prior to the Loma Prieta earthquake. Among those earthquakes were the 1979 Imperial Valley earthquake, with 6.6 magnitude (1), the 1986 Trinidad-Offshore earthquake, with 7.0 magnitude (4), and the 1983 Coalinga earthquake, with 6.5 magnitude. (1) The Trinidad-Offshore earthquake caused the collapse of a freeway bridge (Fields Landing Overhead) that had not been retrofitted. That collapse resulted from inadequate bearing support of simply supported spans. The estimated ground acceleration at the bridge site was only 0.10 to 0.15g. (4)

The 1989 Loma Prieta earthquake was a magnitude 7.1 earthquake. The peak ground acceleration was measured at 0.54g at Capitola, approximately 7 miles from the epicenter, and it was measured at 0.33g at the San Francisco International Airport, approximately 50 miles from the epicenter. (5) That earthquake affected the San Francisco metropolitan area which has a high density of freeway interchanges and bridges. Many bridges in the area had been retrofitted under California's superstructure restraining program. Two bridges failed as a result of the Loma Prieta Earthquake. One of those bridges, the Cypress Viaduct, had been retrofitted with longitudinal restrainers. Although the restrainers did not prevent the collapse of that structure, they also did not contribute to its collapse. Investigations of the collapse of the Cypress Viaduct indicated that the mode of failure was not in the longitudinal direction, and restrainers pulling down spans would have inevitably involved longitudinal collapse of the bents. (6) The collapse of the Cypress Viaduct has commonly been attributed to inadequate reinforcing connecting the columns of the upper and lower bents. The ground acceleration at the Cyprus Viaduct was estimated as

0.25g. (6) Although detailed investigations of all of the bridge structures affected by the Loma Prieta earthquake have yet to be reported, it is evident from the number of bridges that failed in the Loma Prieta earthquake that bridges were generally more resistant to seismic forces during the Loma Prieta earthquake than they were during the San Fernando earthquake. This better performance is attributable to California's superstructure restraining program. However, it is difficult to say how the bridge structures, especially substructures, would have performed if the Loma Prieta earthquake had had a higher magnitude, had shaken the ground longer (i.e., had a greater energy input), or had been accompanied by a sizeable aftershock.

The California seismic retrofit program did not use base isolation as a routine retrofit measure. At the time the program was initiated, base isolation of bridges was considered an experimental approach with a relatively high cost. Three bridges were retrofitted with lead-rubber base isolation units before the Loma Prieta earthquake. One of those bridges (Sierra Point Overhead) was located between the San Francisco Airport and Candlestick Park. That bridge was built in 1957 and designed for a 0.15g static seismic load. Under California's new seismic design loads, the columns would be overstressed by a factor of 5. (7) In the Loma Prieta earthquake, none of California's three base isolated bridges were subjected to a condition that would indicate the performance of their base isolation installations. (8) Apparently, larger ground motions were needed to activate those installations. Thus, regardless of the satisfactory performance of those base-isolated bridges, the performance of their base isolation installation units can not be judged by the Loma Prieta earthquake. However, records exist of the satisfactory performance of a New Zealand bridge with lead-rubber base isolation units that was subjected to an estimated ground acceleration of 0.4g in 1987. (7) Base isolation may be the only retrofit alternative when the restraining superstructure results in overloading columns and foundations, and retrofitting the substructure is not technically and economically feasible. However, there are concerns that base isolation may amplify the response of structures built on softer soils. (9)

LONGITUDINAL JOINT RESTRAINERS

- (a) The California Department of Transportation has used both cables and rods as longitudinal joint restrainers. Those cables and rods are designed to act elastically to avoid loss of support at narrow bearing seats. Thus, these devices do not dissipate any significant amount of energy, and post-elastic ductility of the restrainers is not considered to be a particular advantage. Examples of typical restrainer installations are shown in Figures 1 through 6 and Figure 8.
- (b) The California Department of Transportation has used two types of restrainer materials in its installations. Those are 3/4-inch galvanized steel wire ropes (cables) and 1-1/4-inch galvanized high strength steel rods. The cables (6 strands with 19 wires per strand; ASTM designation A603) have a yield strength of 39.1 kips (176.1 ksi based on 0.222 sq. in. cross section) and a modulus of elasticity of 10,000 ksi (before initial stretching). The rods (ASTM designation A722; plus minimum elongation of 7 percent in a 10-bar diameter before fracture (10)) have a yield strength of 147.1 kips (120 ksi) and a modulus of elasticity of 30,000 ksi. The rods have more ductility than the cables beyond the elastic range. (10) Recently, epoxy coated steel strands of up to 0.6-inch diameter have been developed by steel suppliers. Those strands may be a viable alternative to the galvanized materials used in California, since such galvanized materials are sometimes subject to embrittlement.
- (c) The shorter the cable and rod restrainers are, the more economical is the installation. However, short restrainers may add to the stiffness of the system. This stiffness may in turn subject the system to a higher seismic load and require a larger number of restrainers. On the other hand, because of elastic stretching, the length of the restrainers is limited by the width of the available seat. Such considerations have been the basis for determining the number and length of restrainers.
- (d) Cables are flexible and can accommodate transverse and vertical movements. Rods, however, can accommodate less vertical and transverse movement than cables, and

vertical restrainers may be required to prevent shear failures in the rods. Conversely, cable restrainers may not have a high enough load capacity for certain superstructure configurations. In those circumstances, rod restrainers may be more practical.

- (e) The effective restraining of spans on piers requires positive tying of the spans to the piers. In this case the bent must be sufficiently strong to resist the consequent seismic forces. Also, vertical clearances under the structure near the bent should be considered. To prevent excessive overloading of the pier, it may be possible to forgo a positive tie between each span and the pier and to tie only the adjacent spans together. However, that measure's effectiveness depends on the cumulative openings of the expansion joints, and it may not prevent the spans from becoming unseated unless the bridge is relatively short, with a small number of spans and/or relatively wide bent caps. Also, tying the adjacent spans together does not provide the additional vertical restraint that is provided by tying the spans to the piers. It is customary in design to neglect the consequences of vertical earthquake motion. However, in practice, that component can have a significant effect on deformation, and vertical as well as horizontal restraint is desirable.
- (f) Positive tying of spans to piers has been accomplished by attaching cable restrainers to concrete girder webs (Prestressed I-beam and T-beams, Figure 1) and to steel girder flanges (Figure 2). In the former case, a hole is drilled in the web and the cable restrainer is passed through the hole. In the latter case, the connection is made by welding or bolting to the flange. Attaching the restrainer to the pier has been done by passing the cable restrainer through a hole drilled in the pier cap and anchoring. The restrainer can be attached to an abutment wall by grouting the end of the restrainer in a hole drilled in the wall (Figures 3 and 4). The individual strands of the cable should be splayed apart in the grout hole to assure a better bond.

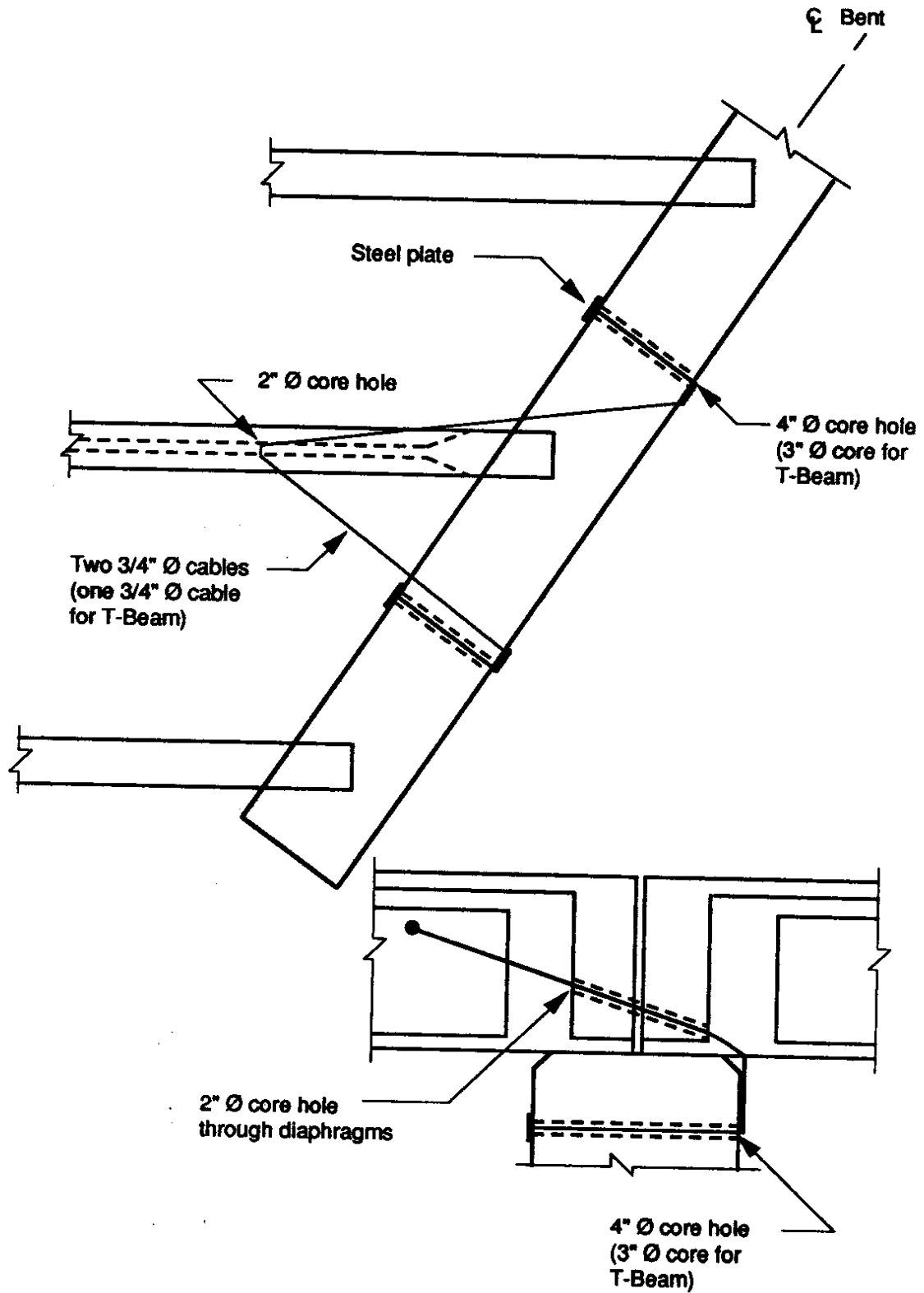

Figure 1. Prestressed I-Beam, and T-Beam, to Pier Cap Connection

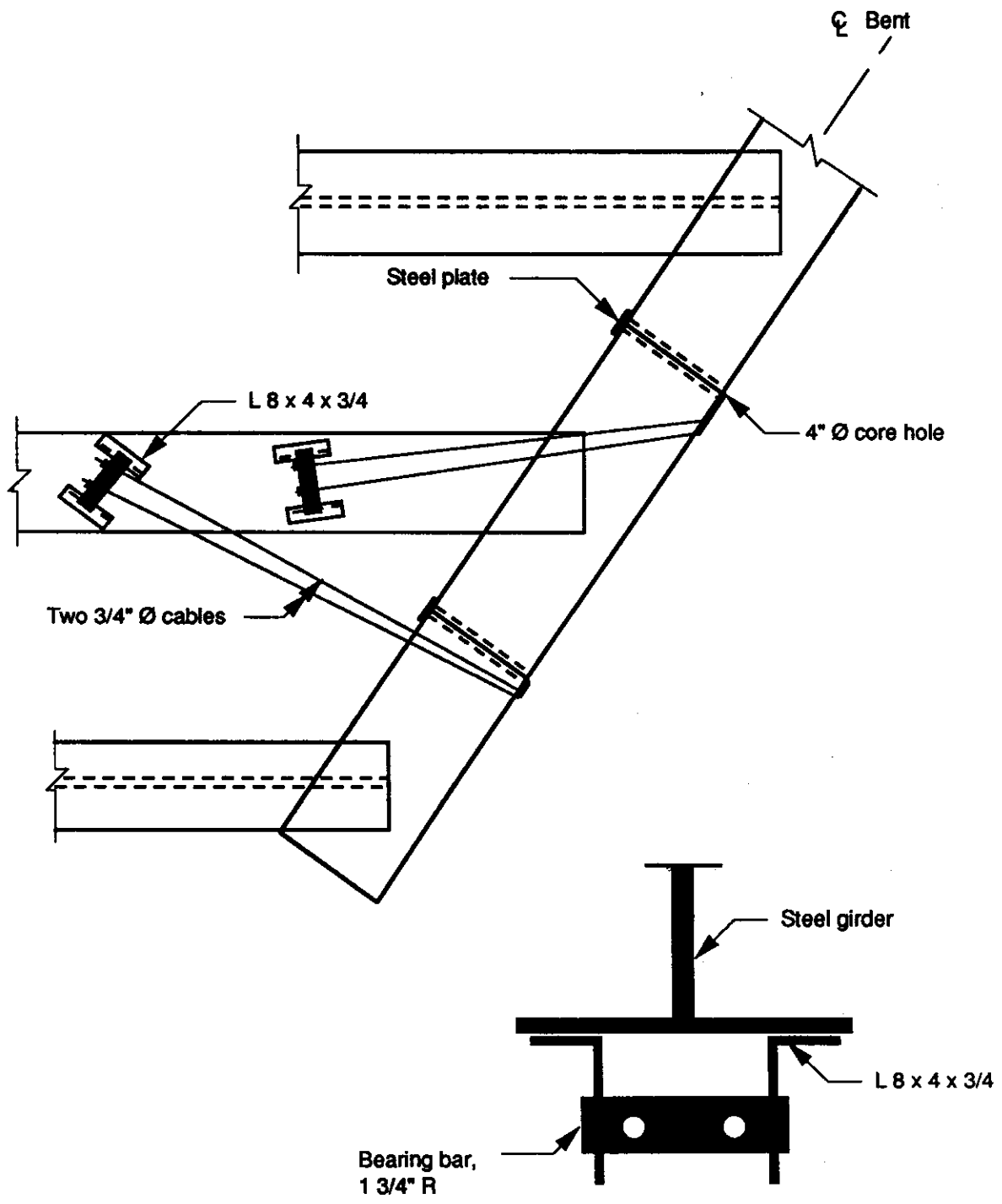

Figure 2. Steel Girder to Pier Cap Connection

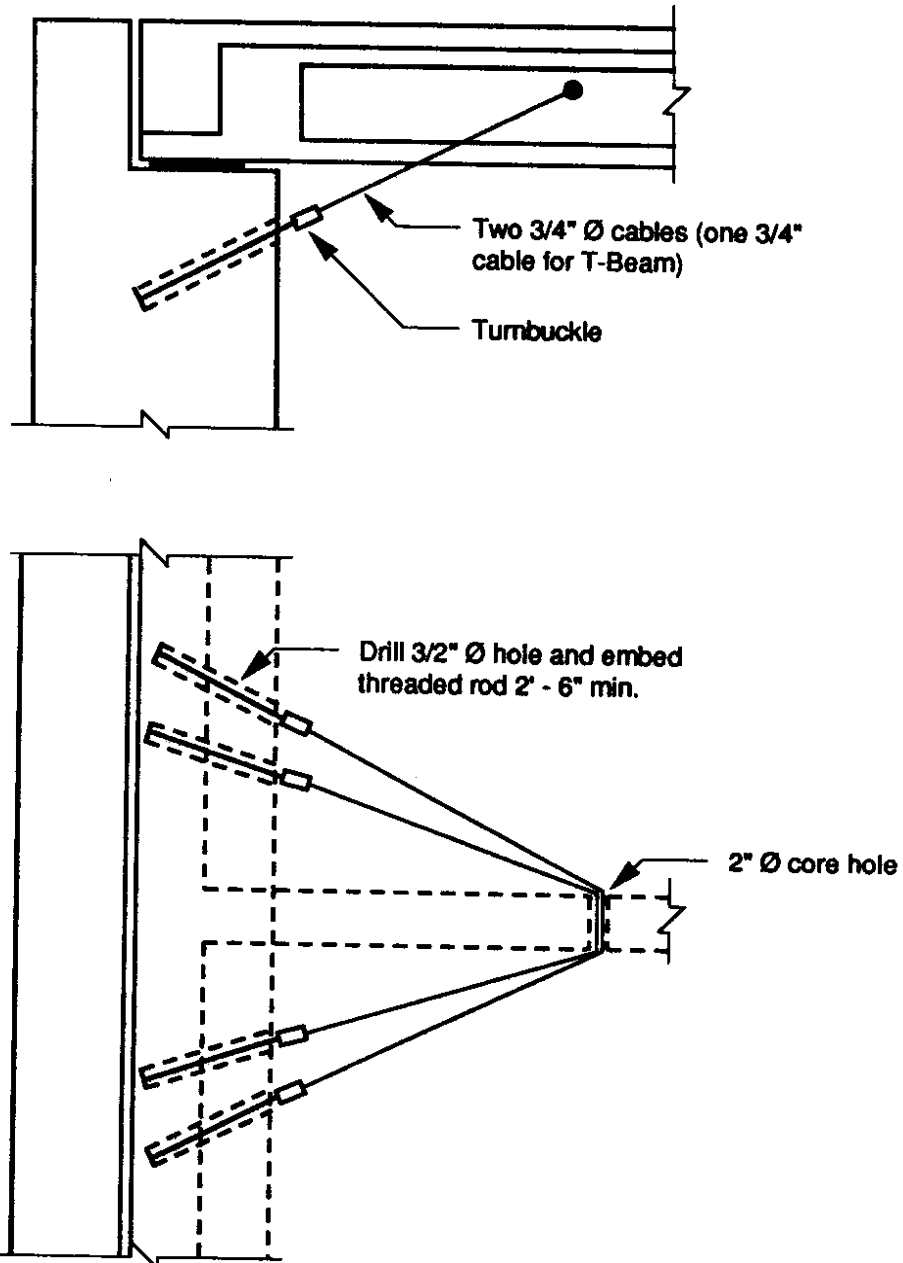

Figure 3. Prestressed I-Beam, and T-Beam, to Abutment Wall Connection

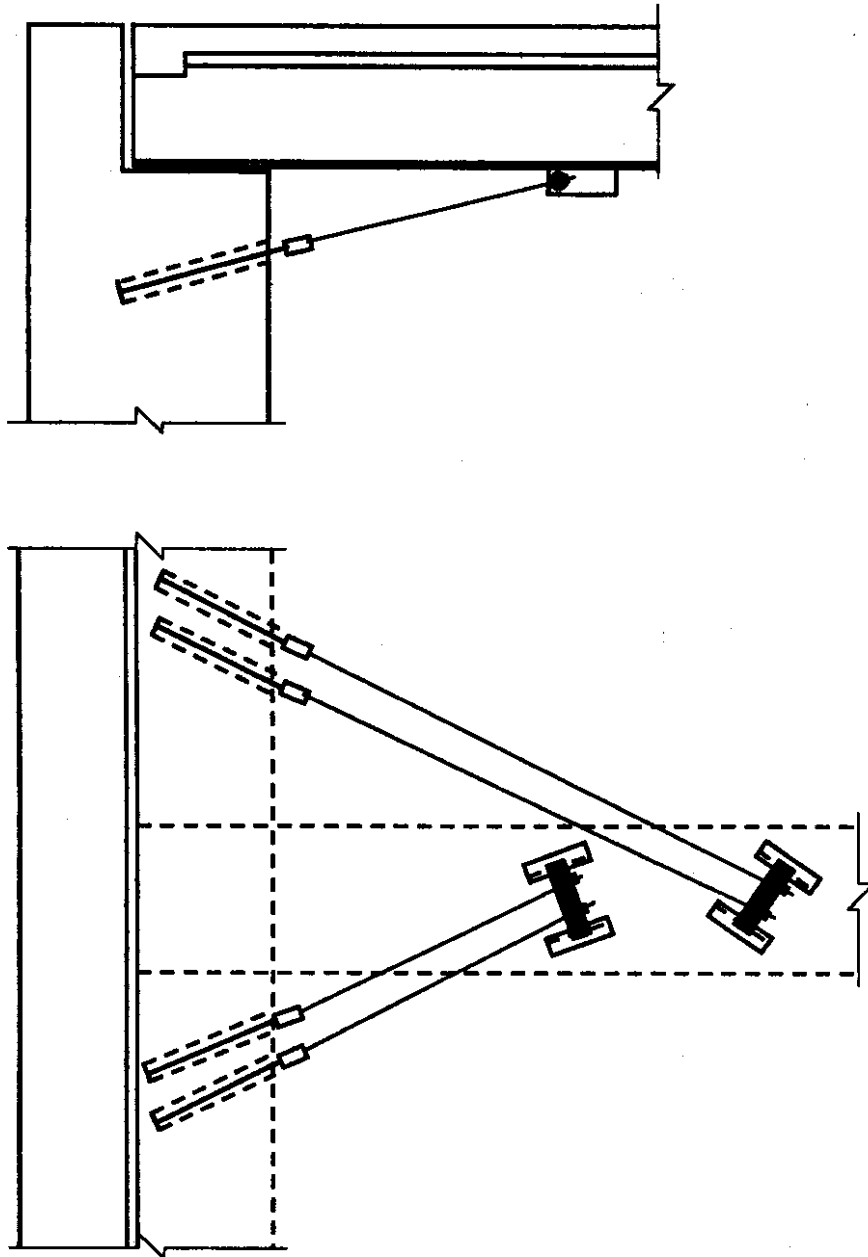

Figure 4. Steel Girder to Abutment Wall Connection

- (g) In a bridge consisting of prestressed concrete girders, restraining the girders may subject girders to forces exceeding the prestressing force during a major earthquake. This condition should be considered when the restrainers are designed. Long multi-span bridges may be more prone to this phenomenon because of the possibility for the structure to respond out-of-phase. If the forces generated in the girders are a concern, attaching the restrainers to the underside of the deck (instead of the girder web) may be a better alternative. That alternative has been practiced in California. (11)
- (h) Connection devices for restrainers should not fail under any seismic loading condition because such failures would be of a brittle nature. To satisfy that requirement, the connections must be designed to be at least 25 percent stronger than the restrainers. Also, past experience has shown that turnbuckles (used to connect a cable restrainer to its anchorage assembly, or to connect two ends of a cable restrainer together) have the potential to fail in earthquakes as low as magnitude 5.9. (12) The failure has occurred when the turnbuckle stud has stripped out of the coupler because the stud was inserted inadequately into the turnbuckle. The capacity of turnbuckles to reliably resist forces 25 percent greater than the actual, as opposed to the specified, cable capacity should be documented.
- (i) Anchoring restrainers to the abutment wall by drilling the concrete and polymer grouting (Figures 3 and 4) may not be prudent if information on the long-term performance of the polymer is not available. The bond strength of some polymers may gradually deteriorate over time. That deterioration would be unnoticed for retrofit elements during the service period of the bridge. Bond between any grout and the hole wall is highly dependent on removal of all debris and dust from the hole before grouting.
- (j) Restrainers should have redundancy so that when a single unit fails because of faulty fabrication or installation, the remaining units have enough capacity to pick

up their increased share of the load. Experience has shown that when redundancy is not provided, the failure of one restrainer can reduce the load capacity of the restrainer system, thereby overloading the remaining restrainers and leading to their failure as well. (12)

- (k) To effectively restrain a mid-span hinge, restrainers should be oriented in the principal direction of the expected movement. When there is no possibility for span rotation (piers are rigid in the transverse direction, as is the case for slab piers), restrainers should be placed longitudinally. When there is a possibility of span rotation, as is the case for flexible piers such as a one column pier in a skewed bridge, restrainers should be placed normal to the joint.
- (l) Restraining mid-span hinges of continuous structures may reduce the seismic forces in the columns. (13) When the hinges are not restrained, a continuous segment of the bridge may act independently, and its inertia forces may be transferred to its substructure only. When a hinge is restrained, the inertia forces may be transferred to both the bridge's substructure and the restraining system. However, the contribution of the restrainer to the stiffness of the segment may increase inertia forces to such an extent that the net effect will be an increase in the substructure forces. Thus, each bridge should be studied individually before any conclusions is drawn.
- (m) A commonly used detail for retrofitting mid-span hinges of concrete box girders in California has been a diaphragm installation of 7-cable units (Figure 5). Each unit is placed in a cell adjacent to the hinge, is threaded through two parallel holes drilled in the hinge diaphragms, and is anchored in the companion cell on the other side of the hinge. Thus, each 7-cable unit provides the capacity of 14 cables in tension. This system can subject the diaphragms to high levels of concentrated loads in the event of a major earthquake. To prevent destruction of the diaphragms, concrete bolsters are generally installed beneath the anchor plates to spread out the

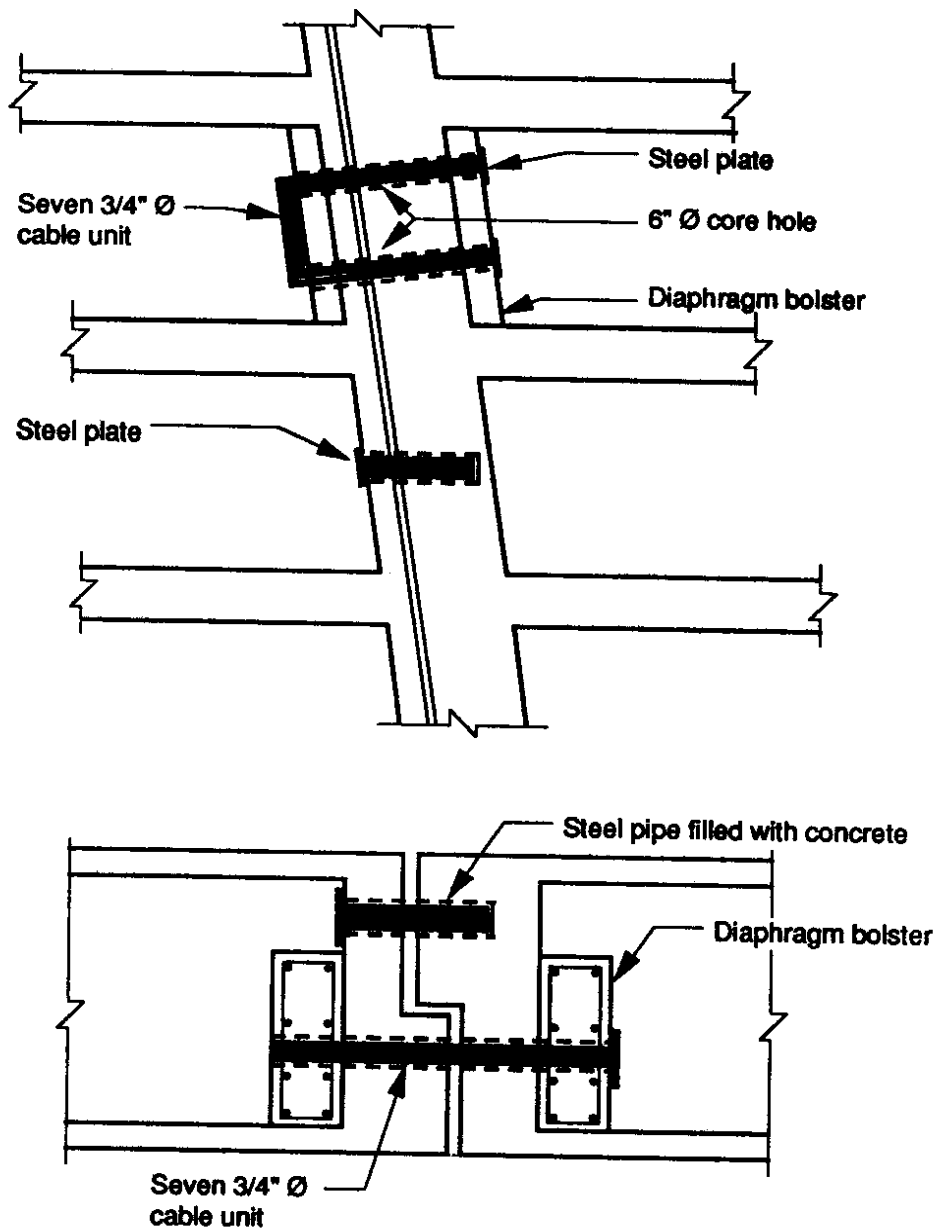

Figure 5. Box-girder Mid-Span Hinge Longitudinal and Transverse Restrainers

concentrated forces. However, it is important that bolstering of a diaphragm does not result in seismic-induced damage to the adjacent girders. Thus, the capacity of the restraining unit should not allow the girders to fail before the restraining unit fails. If the 7-cable unit is too strong for the girders, then the number of the cables in the unit may be decreased and the number of units in the superstructure increased. To prevent transverse bending of the superstructure, one unit in each exterior cell is considered the minimum requirement.

- (n) If cable units do not have a capacity high enough for retrofitting the mid-span hinges of a box-girder bridge (a working load design capacity of 30.5 kips per cable, based on 50 percent of the ultimate strength plus 33 percent overload), then high strength rods may be used. Those rods usually tie the hinge diaphragms to the adjacent bent cap (and have a working load design capacity of 115 kips per rod). An advantage of rod units is that they require smaller holes to be cored through bridge concrete elements than do cables.
- (o) Unlike box-girder bridges, in T-beam bridges, mid-span hinges may not be restrained by connection to the diaphragms because the diaphragm has a lower capacity as a result of the lack of a support at the bottom edge of the diaphragm. In this case, the webs of companion girders on the sides of the hinge are tied together (Figure 6). Cables have been used for this purpose. Typically, four cables are threaded through holes drilled in the webs of the companion girders and through holes drilled in other concrete elements. Turnbuckles are used to connect the ends of the cables. Also, it is possible to attach the restrainers to the underside of the deck instead of the webs of the girders. When the latter alternative is used, it is necessary to locate the connection to the deck a sufficient distance from the hinge to prevent damage to the ends of the span.
- (p) Cable restrainers may allow the faces of concrete diaphragms in mid-span hinges, or the ends of concrete girders in joints over piers, to batter against each other

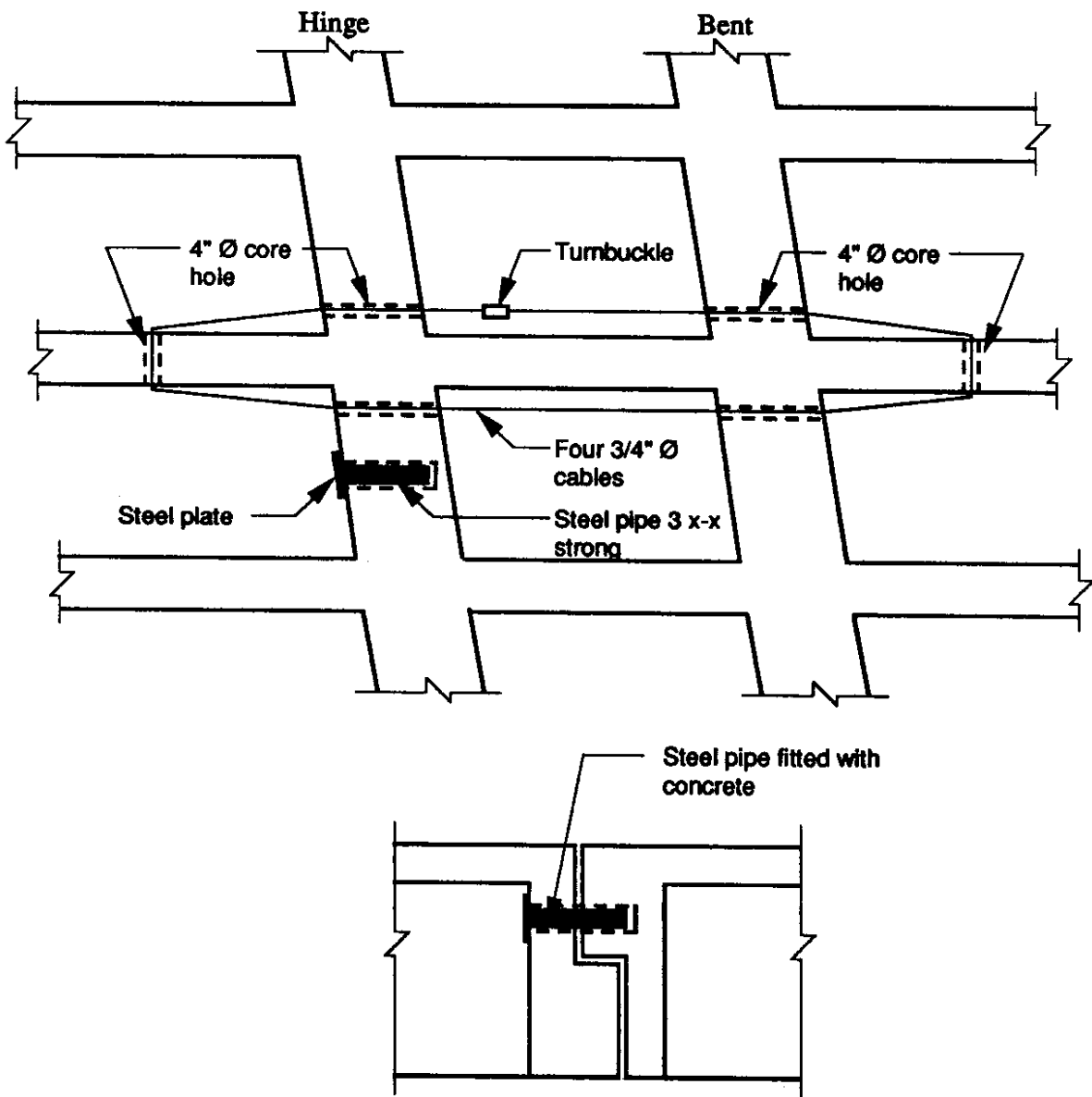

Figure 6. T-Beam Mid-Span Hinge Longitudinal and Transverse Restrainers

- during a major earthquake. This bumping may cause damage, but the damage should be repairable and not extensive enough to allow the span to drop. (10)
- (q) A gap in the restrainer system allows thermal expansion during normal service. That gap creates a sharp transition in the restrainer force during a major earthquake. A restrainer system should be designed to smooth this performance to reduce the impact effects on both the restrainer and its anchoring devices. For example, where the end of a restrainer is anchored to a concrete element (after a hole has been drilled and threaded), a thick rubber pad placed on the face of the bearing plate and in front of the lock nut (Figure 7) can allow changes in length caused by temperature variations, while simultaneously reducing, because of its elasticity, the impact effects caused by earthquakes.
- (r) A method proposed for restraining the mid-span hinges of steel girder bridges comprises restrainer rods that tie together the hinge headers (Figure 8). (14) Two rods, typically 3/4 inch diameter ASTM A307 rods, have been proposed for each interior girder line, although more realistic seismic loads may require stronger rods for typical applications. Each rod is placed on one side of the girder line. The rods are threaded through holes drilled in the headers. The rod is anchored to a header with a lock nut placed over a 1-inch thick, partially compressed rubber pad to allow for changes in length caused by temperature variation. Additionally, that configuration may provide a smooth performance during an earthquake. The header is stiffened where the rod is anchored to the header by a diagonal brace. One end of the brace (typically a channel) is welded to the web of the header and the other end to the web of the adjacent girder.
- (s) Generally, in steel girder bridges hanger type hinges have more seismic resistance against longitudinal movement than seat type hinges. However, they may still be subject to damage under longitudinal seismic loading. (11)

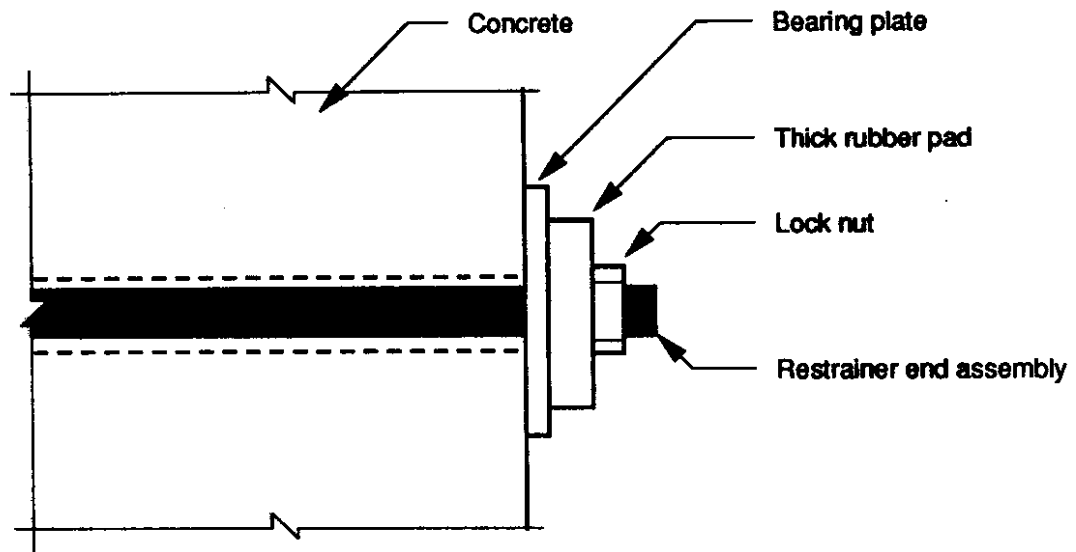

Figure 7. Desirable Details for Insuring a Smooth Build-Up of the Restrainer Force in the Event of a Major Earthquake

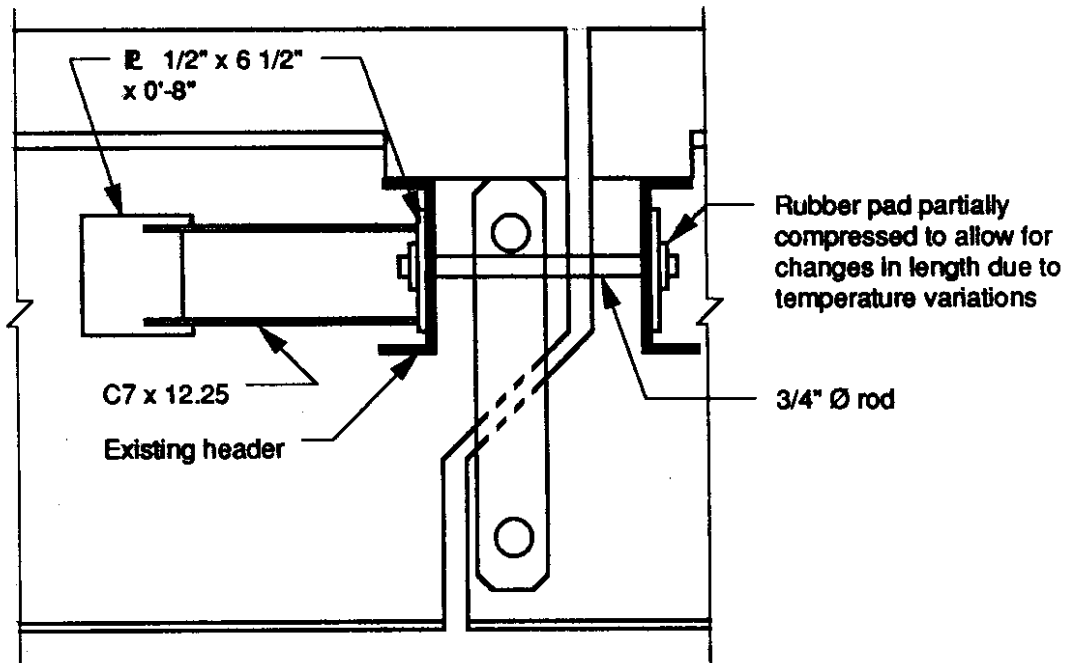

Figure 8. Steel Girder Mid-span Hinge Longitudinal Restrainer (Ref. 14)

TRANSVERSE BEARING RESTRAINERS

- (a) Transverse bearing restraint is provided when transverse bearing movement is likely to result in loss of support and instability. Non-seismic transverse bearing restraints, such as nominal keeper plates and anchor bolts, are subject to failure in Seismic Performance Category (SPC) C and D structures (structures subject to ground accelerations higher than 0.19g). (10) Nominally designed concrete shear keys may provide transverse bearing restraint in SPC C structures (structures subject to ground accelerations limited to 0.29g). (10) Where non-seismic transverse restraints are ineffective, girders are vulnerable to collapse if either of the following conditions exists:
- a. Individual girders are supported on individual pedestals or columns, or
 - b. The exterior girder in a two- or three-girder bridge is near the edge of a continuous-bearing support.
- (b) Even with a continuous-bearing support in a bridge with more than three girders, a skewed bridge has a tendency to rotate, move laterally, and become unseated when shaken by a major earthquake. Narrow, continuous segments are more prone to become unseated than those with low length-to-width ratios. When the ratio of length-to-width is low, the superstructure may be "locked-in" and may not drop. When the skew is less than 40 degrees and the length-to-width ratio is less than 1.5, the bridge may not have vulnerable details. (10) Skewed, continuous, single-column bridges are especially vulnerable, since they are inherently narrow and they do not offer sufficient rigidity against rotation. Skewed, single, simple span bridges, regardless of their inherent lower length-to-width ratio, may still drop, depending on the geometry of the structure and the magnitude of the seismic forces.
- (c) Continuous, curved segments of a bridge have a tendency to move away from the center of the curve laterally. In this case transverse seismic deflection contributes to the longitudinal opening of the joints between the segments. This phenomenon can

contribute to dropping of the superstructure, unless longitudinal restrainers are used. The higher the length of the segments and the lower the radius of the curve are, the larger will be the longitudinal joint opening.

- (d) In highly skewed bridges with longitudinal girders, transverse restraining of bearings on piers, or abutments, may be done with cable restrainers. In this case, one end of the cable is attached to the girder perpendicularly while the other end is anchored to the pier cap, or abutment wall. In prestressed I-beams, the cable can be threaded into a hole drilled in the end block and anchored. In steel girders, the cable may be welded to the bottom flange. This type of transverse restraining may not be suitable for T-beam bridges.
- (e) The California Department of Transportation has developed a method of transversely restraining concrete structures. A double strong steel pipe (typically 3- to 4-inch diameter and 2.5 to 3-feet long) is placed in a hole drilled in the concrete elements located on the sides of the joint and filled with concrete. The hole is drilled in the bays between the girders. The method is well suited to restraining mid-span hinge diaphragms against each other (Figures 5 and 6) and restraining the end diaphragm against the abutment backwall. The design is based on the pipe bearing against the walls of the drilled hole. A 4-inch pipe restrainer has a load-factor design capacity of 175 kips, based on a 50 percent increase in the allowable steel shear stress. (10) In well reinforced diaphragms, the full concrete compressive strength may be relied on. However, at highly skewed joints, care should be taken not to rely on the full strength of acute corners because they can easily break off.
(10)
- (f) Steel girders on piers and abutments can be secured against transverse seismic movements with the installation of properly designed keeper plates and anchor bolts. Those restrainers are usually designed to resist load elastically. Two factors should be considered in designing those restrainers. First, when columns yield,

additional forces will be transferred to those elements. Second, those elements are likely to be built with different construction tolerances and thus to resist seismic loads unevenly. To account for those factors, the transverse restraining elements are designed for loads 25 percent greater than those obtained from an elastic analysis.

- (g) Any seat and hanger type mid-span hinge used with steel girders is likely to need transverse restraining in even moderately severe seismic areas. (11) Those hinges often have lugs attached to the bottom flanges (windlocks). Those devices are usually structurally inadequate for even moderate seismic loading because they are too small. A steel plate, typically 17 inches wide and 1.5 inches thick, connected to the bottom flange for 12 inches, is used to restrain the relative transverse seismic movements of a girder line at the hinge (Figure 9). That plate clears the opposite girder flange by 1/8 inch and extends underneath that flange for typically 8 inches. Restraining a girder against the opposite girder is done with two plates, each typically 1.5 inches thick and 7 inches long, welded to the "flange plate" on each side of the opposite girder.

BEARING SEAT EXTENSION

- (a) Bearing seat extensions at abutments or piers may be considered when it is impractical to restrain seismic movements enough to prevent loss of support. The extended seat should provide a minimum width equal to or greater than that required by Section 4.6 of "Seismic Retrofitting Guidelines for Highway Bridges." (10)
- (b) Concrete extensions scabbed onto the abutment or pier face through dowels grouted in drilled holes may not be a good solution. The magnitude of the impact of the dropped superstructure, in conjunction with the horizontal seismic load, may tear the extension from the face of the abutment or pier. (10, 11) Thus, it is important that the extension be raised above the level of the abutment, or pier, to mitigate the magnitude of that impact (Figure 10). This is especially important where the bearings have large vertical dimensions. Additionally, consideration should be

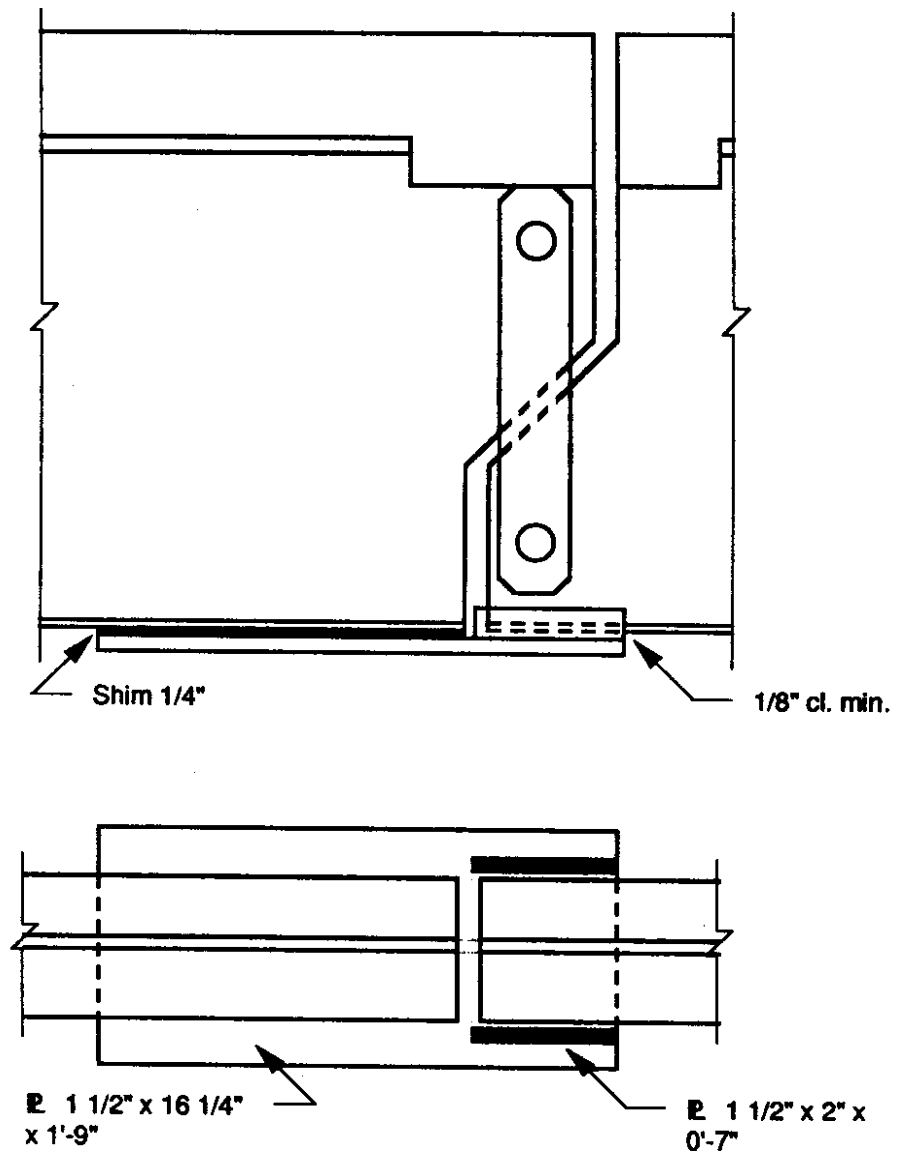

Figure 9. Steel Girder Mid-Span Hinge Transverse Restrainer

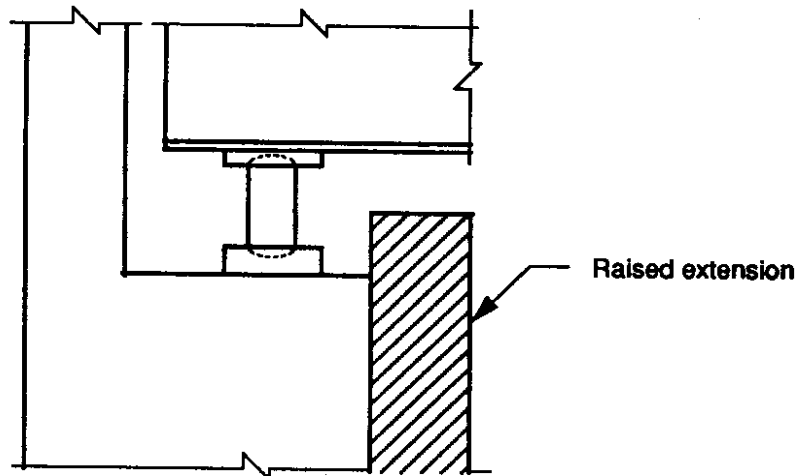

Figure 10. Bearing Seat Extension

given to post-tensioning the extension to the abutment or pier. A better alternative than post-tensioning is to provide a well reinforced concrete extension carried to the existing foundation and tied back to the abutment or pier.

REPLACEMENT OF VULNERABLE BEARINGS WITH CONVENTIONAL BEARINGS

- (a) Certain types of both expansion and fixed steel bearings (e.g., rocker bearings), because of their large vertical dimension, can easily become unstable in the event of an earthquake and topple. All bridges in SPC-D (structures subject to ground accelerations higher than 0.29g) are vulnerable to this type of failure. Bridges in SPC-C (structures subject to ground accelerations higher than 0.19g, but limited to 0.29g) are vulnerable only when the support skew is greater than 40 degrees. (10) If toppling of the bearings is likely to result in collapse of the superstructure, then replacement of the bearings should be considered.
- (b) Expansion type bearings may be replaced with elastomeric bearing pads. To maintain the proper elevation of the superstructure, a reinforced concrete cap should

be constructed to build up the elevation difference between the elastomeric pad bearing and the original bearing (Figure 11). Jacking of the superstructure can permit removal of the unstable bearings and construction of the new concrete cap. Typically, the cap is secured to the existing concrete with No. 6 bars grouted in that concrete to a depth of 8 inches. Transverse restrainers in the form of reinforced concrete shear keys can be provided by constructing a new concrete cap at a higher elevation between the girders.

- (c) Fixed type bearings generally do not need to be removed. They can be enclosed in a reinforced concrete cap to reduce the vertical dimension and provide stability (Figure 12). Reinforced concrete shear keys can be provided between the girders by suitable configuring of the new concrete cap.

BASE ISOLATION BEARINGS

- (a) Ideally, a base isolation bearing should be capable of reducing seismically induced forces, reducing relative displacements across the bearing, dissipating energy, and returning the structure to the pre-earthquake position. Additionally, the bearing should perform satisfactorily under normal service conditions. Such behavior may eliminate the need to restrain the superstructure longitudinally and/or transversely. More important, it may eliminate the need to retrofit the substructure because of the reduced level of the seismic forces. Base isolation may be the only retrofit alternative when restraining the superstructure results in overloading of the substructure, and retrofitting the overloaded substructure is not feasible.
- (b) Currently, a worldwide interest exists in the development and use of base isolation bearings. Japan, Italy, and New Zealand have constructed, or retrofitted, bridges utilizing base isolation bearings. For example, in Japan in the 1970's, more than a hundred prestressed concrete railway bridges were built that incorporated sliding bearings and viscous dampers for longitudinal isolation. The isolation devices comprised shear keys embedded in a highly viscous material. (15) During an

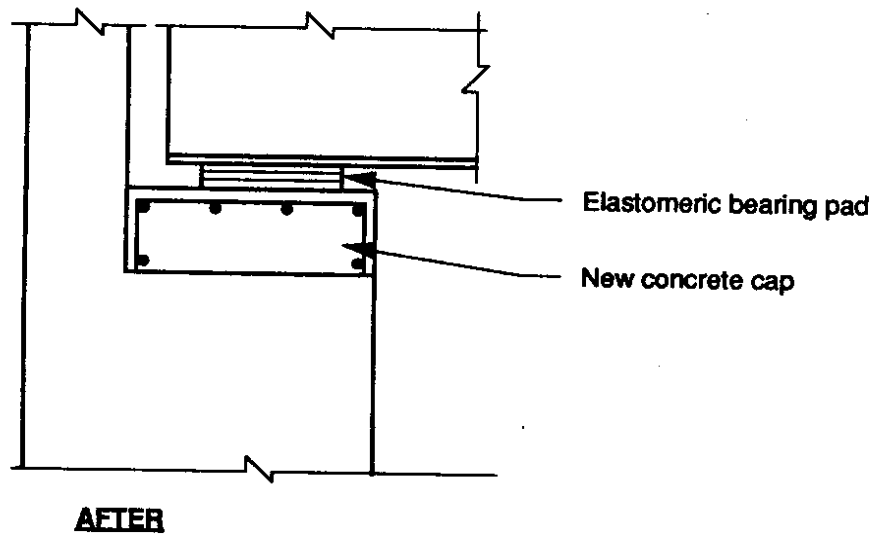
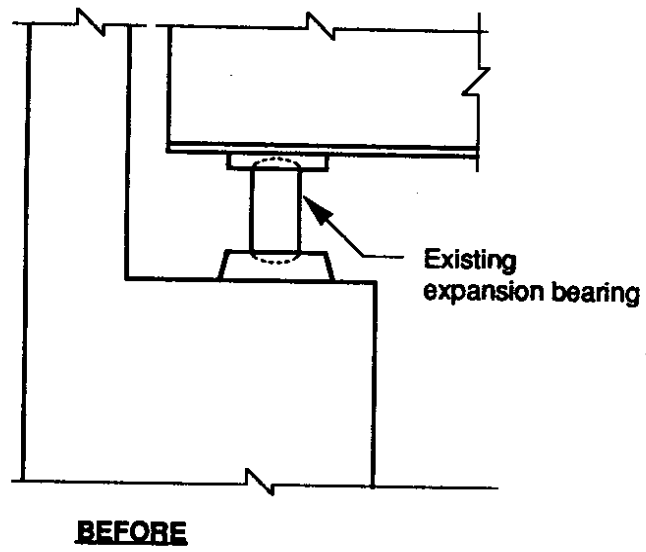

Figure 11. Replacement of Vulnerable Steel Expansion Bearing

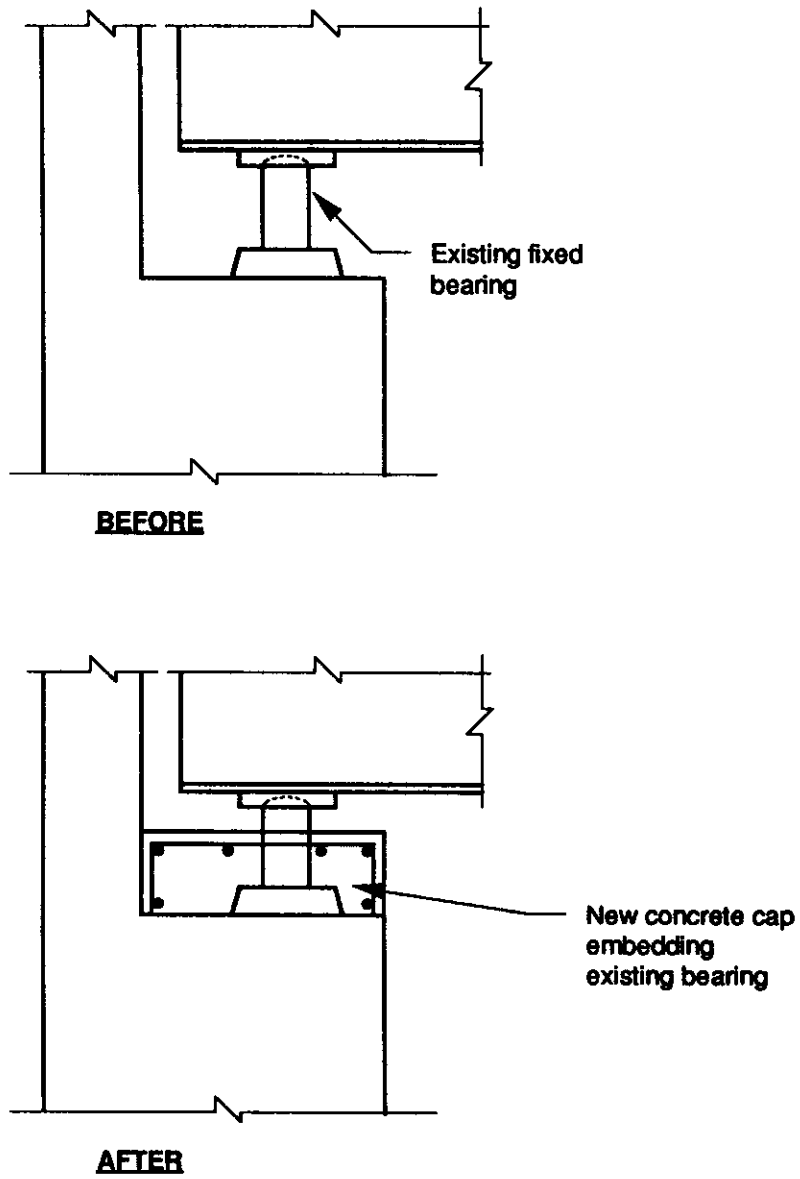

Figure 12. Modification of Vulnerable Steel Fixed Bearing

earthquake, rapid movement of the key would be resisted by the viscous material, thus reducing the load transferred to the substructure. In Italy, 31 bridges have been constructed that use sliding bearings and energy absorbers. Typical construction comprises a continuous prestressed concrete box-girder superstructure with slide bearings at all piers and one abutment. Seismic resistance in the longitudinal direction is provided only in the other abutment by the incorporation of absorbers made of rubber pads and bellows fabricated from ductile steel. The total yield capacity of all absorbers at that abutment is designed to be less than the total prestressing force in the box girder. (15) One disadvantage of these devices is that they work in one direction only. Thus, sufficient restraint in the other horizontal direction must also be provided, and the pier must be capable of resisting the seismic forces in that direction. Further, since normal wear (e.g., leaking of the viscous systems) can produce system failure, a positive backup system, such as one of elastic restrainers, may be necessary.

In New Zealand, of the approximately 2,600 bridges on the country's highways, 37 bridges had base isolation systems by 1986. Eight of those bridges were retrofitted. (15,9) This relatively high commitment to seismic isolation was the result of the development of low cost, low maintenance mechanical energy dissipaters in New Zealand, which could be fitted to most standard bridge designs. One of the most highly developed energy dissipaters is the lead-rubber device, in which a cylinder of lead is enclosed in an elastomeric bearing pad. The elastomeric bearing pad replaces existing non-seismic bearings at piers and/or abutments. While the elastomeric pad provides flexibility to reduce the seismic forces by increasing the period of vibration, the lead cylinder limits the relative displacements across the bearing by yielding and dissipating energy. The elasticity of the elastomeric pad tends to return the superstructure to its original position. Additionally, the rigidity of the lead cylinder provides restraint against movement at the normal service. New

Zealand now has specific design recommendations for base isolated structures written into its code of practice for the design of concrete structures. (15)

In the United States, at least one bridge has been built with a viscous damping base isolation device (Dumbarton Bridge, San Francisco Bay, California (10)), and five bridges have been retrofitted with the lead-rubber base isolation device. (7) Three of those bridges are owned by the California Department of Transportation, one bridge is owned by the Los Angeles County Transportation Commission, and one bridge is owned by the Metropolitan Water District of Southern California. The design acceleration spectrum used for those five retrofitted bridges ranged from ATC 0.4g, S-2 to Caltrans 0.6g, S-4. (7) The calculated base shear coefficient of those five retrofitted bridges ranged from 0.17 to 0.32, and their maximum isolator displacement ranged from 3.85 inches to 12.88 inches. Generally, the lead-rubber isolation bearings reduce seismic forces by 2 to 5 times in low to moderate seismic regions (with a ground acceleration lower than 0.20g), and by 5 to 10 times in higher seismic regions (with a ground acceleration larger than, or equal to, 0.20g). (7)

- (c) The lead-rubber isolation bearing is composed of alternating layers of rubber and thin steel reinforcing plates bonded together (Figure 13). The lead core is tightly fitted into a preformed hole. Two steel load plates, substantially thicker than the steel reinforcing plates, accommodate connection to the superstructure from above and to the substructure from below. Those plates distribute the vertical load of the superstructure and transfer shear into the lead-rubber unit. In retrofit projects, keeper plates welded to the sole plate and the masonry plate are usually used to transfer seismic loads into the lead-rubber unit. The keeper plates bear against the sides of the two steel load plates at the top and bottom during an earthquake (Figure 13).

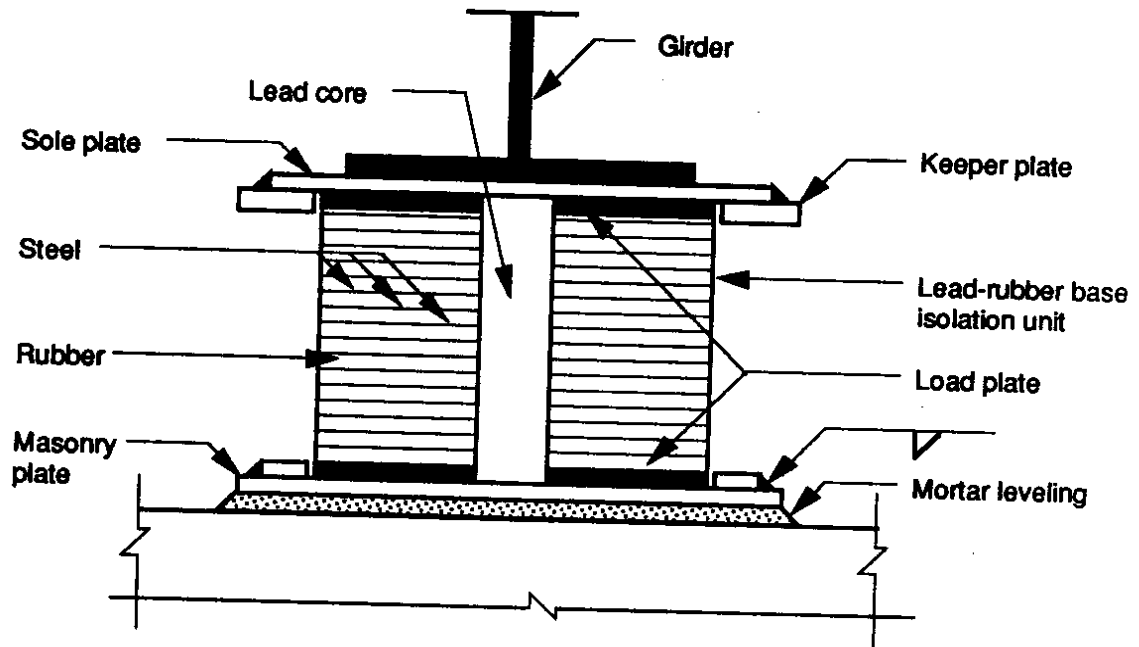

Figure 13. Lead-Rubber Base Isolation Bearing
(Adapted from Reference 22)

- (d) In a lead-rubber base isolation unit, the diameter of the lead core is determined on the basis of short term loads, such as wind and braking loads, to maintain rigidity through the elastic response under those loads. Note that the stress relaxation properties of the lead core significantly reduce its stiffness against long-duration displacements caused by changes in temperature, creep, and shrinkage.
- (e) The plan size and the thickness of the internal rubber layers are determined on the basis of the dead and live load requirements to prevent excessive loading and bulging of the unit.
- (f) The overall thickness of the rubber in a lead-rubber unit is determined on the basis of the level of isolation required (i.e., the base shear coefficient required), depending on the amount of dead load applied and the diameter of the lead core selected. Generally, taller units, units with higher vertical loads, and those with

smaller lead core diameters have lower stiffnesses and result in lower seismic loads and larger displacements.

- (g) Aging of an elastomer can increase its stiffness, especially when the exposed surface is relatively large. The limited data available suggest that the stiffness of natural rubber does not change significantly with time. In two cases, increases in natural rubber stiffness of about 10 percent and 15 percent have been experienced after 20 and 30 years of service, respectively. (7) That level of stiffening should cause a negligible change to the seismic response of the isolated structure, since a 25 percent change in shear modulus makes only a 10 percent change in the period of vibration ($T = 2\pi(M/K)^{0.5}$), and most spectra are relatively flat in the period range of seismically isolated structures. Unlike natural rubber, neoprene may age and stiffen significantly with time. Some evidence suggests that neoprene stiffens by a factor of between 2 and 3 in a period of about 15 years. (7)
- (h) The stiffness of the elastomeric compound may increase at low temperatures. The stiffening may be due to instantaneous thermal stiffening and/or to crystallization, which is time dependent. Instantaneous thermal stiffening may be a problem for Alaska and limited parts of the continental United States. The stiffness increases many times at approximately -40° F for neoprene and at approximately -67° F for natural rubber. (16) Crystallization, on the other hand, occurs over a wide range of long-duration low temperatures (almost any temperature lower than 32° F lasting for several days or more). Low temperature crystallization is primarily a problem of neoprene. Natural rubber generally has high resistance to crystallization, but some natural rubber compounds crystallize quite rapidly. (16) In most parts of the United States, elastomers with low resistance to crystallization can stiffen many times during cold seasons, while the stiffness of those with high resistance to crystallization does not increase significantly. (16)

- (i) In a lead-rubber unit, the lead core deforms in shear by lateral pressure from the internal steel reinforcing plates, if the displacements are large enough. The actual yield level and stiffness values are affected by the size and confinement of the lead core. (17) The internal steel plates plus the externally applied vertical load provide confinement for the lead plug. Where the dead load has not been sufficient to confine the lead core (e.g., abutment dead loads), other types of isolation, such as cantilever tapered steel pin energy dissipaters (18) or lead extrusion energy dissipaters (9), have been used instead of lead-rubber units because their performance is independent of vertical loading. Also, where the axial load has not provided adequate confinement, isolation bearings have been specified with an elastomeric only, without a lead core. (19)
- (j) A bridge isolated with lead-rubber units in New Zealand was subjected to an earthquake in 1987. An earthquake of 6.2 magnitude occurred near the town of Edgumbe and caused severe damage to structures in the region. The State Highway Bridge at Te Teko (a five span, continuous, reinforced concrete bridge on single-column concrete piers supported on batter piles located less than 12 miles from the epicenter) was seismically isolated with lead-rubber bearings at the piers and elastomeric bearings at the abutments. The bridge was subjected to an estimated ground acceleration of approximately 0.4g, with a spectral shape similar to El Centro N-S, 1940. There was no structural damage to the bridge. (7)
- (k) In the Loma Prieta earthquake (1989), none of the California Department of Transportation's base-isolated bridges were subjected to conditions that would indicate the performance of their base-isolations. Those base-isolation installations were designed so that they would be activated after the abutment wall and the soil behind it had broken. That condition, which would allow a sufficient displacement and yielding of the lead-core, did not occur. Apparently, larger ground motions are needed to activate those installations. (8) Thus, regardless of the satisfactory

performance of those bridges, the performance of their base-isolation installations may not be judged by the Loma Prieta earthquake. The peak ground acceleration in that earthquake varied from 0.64g at the slipped fault at Corralitos to 0.33g at San Francisco International Airport. (5) At the Cyprus Viaduct, which collapsed, the ground acceleration was estimated to be 0.25g. (6)

- (l) Seismic isolation cannot work effectively if horizontal restrainers are used in the bridge in conjunction with the isolators. (7) Horizontal restrainers may not allow the isolators to deform through their design displacement, thus becoming an obstacle to proper isolator performance. (7)
- (m) Base isolation of bridges in New Zealand is presently confined to stiff structures founded on firm soils. (9) Seismic base isolation may have limitations if used on soft soils. There is a concern that base isolation may increase the response of structures built on softer soils because of a shift in the predominant period of the earthquake. (9) For example, the predominant period of the 1985 Mexico City earthquake was about 2 seconds, caused in part by the natural period of the overlaying clay deposit. (20) The period of an isolated bridge built with a lead-rubber isolation system is typically in the 2.0 to 2.5 second range. (7) This condition can produce amplification of the surface acceleration, causing extremely high seismic forces in the structure. However, the energy dissipating characteristics of the isolators may mitigate the amplified forces to some extent. A lead-rubber base isolation system has equivalent viscous damping in the range of 20 percent to 40 percent. (7)

CHAPTER 3
COST ESTIMATES OF RETROFIT MEASURES

This chapter presents cost estimates for the superstructure retrofit measures considered in Chapter 2. Generally, the bases for those retrofit measures are the structural details developed by California Department of Transportation. Typical cost estimates were determined by the details of typical retrofit measures and basic item prices. The cost estimates include 30 percent for profit and contingencies, but they do not include traffic control costs.

RETROFIT ITEM PRICES

<u>Item</u>	<u>Unit</u>	<u>Cost</u>
Miscellaneous Restrainer Metal (Cables,Rods, Plates,connections, etc.)	LB	\$ 3.50*
Coring Concrete		
2-inch Diameter Hole	LF	\$ 40.00*
6-inch Diameter Hole	LF	\$ 60.00*
(Interpolate for Intermediate Sizes)		
Grouting (Epoxy Injection)	LF	\$ 20.00
Minor Concrete (Keys, Seats, etc.)	CY	\$ 1,000.00*
Diaphragm Bolsters for Box-Girder (Reinforced Conc., Full Bay Width)	Each Side of Diaphragm	\$ 1,200.00*
Superstructure Access Opening (Box-Girder)	Each	\$ 550.00*
Superstructure Access Closing (Box-Girder)	Each	\$ 780.00
Base Isolation Lead-rubber Bearing (Including Design and Testing)	Each	\$ 3,200.00
Base Isolation Bearing Installation (Bearing plates, connections, etc.)	Each Bearing	\$ 982.00

* The item prices with asterisks were reported in California in 1986. (21) They are for typical urban bridges on a multi-bridge contract, with good access and little traffic interference. Add to all item prices with asterisks 30 percent for profit and contingencies. The prices for base isolation were reported in 1986 from one contract in California. (22) The prices above do not include traffic control costs.

LONGITUDINAL RESTRAINERS (PIER AND ABUTMENT JOINTS)

(a) Prestressed I-Beam Connection to Pier Cap (Figure 1)

Assumptions

Restrainer:

3/4-in. diameter cable restrainers (ASTM A603); two cables per each interior girder; each cable 40-feet long.

Concrete coring:

One 4-in. diameter hole through 3-feet wide pier cap in each bay; one 2-in. diameter hole, 0.5-foot long, through web of each interior girder; two 2-in. diameter holes, each 3-feet long, through diaphragms per each interior girder.

Anchorage:

Two steel bearing plates, each 2 in. by 8 in. by 8 in., per each hole drilled through the pier cap.

Estimated cost

\$ 687.00 per each interior girder, when coring the diaphragms is not required.

\$ 999.00 per each interior girder, when coring the diaphragms is required.

(b) Prestressed I-Beam Connection to Abutment Wall (Figure 3)

Assumptions

Restrainer:

3/4-in. diameter cable restrainers (ASTM A603); two cables per each interior girder; each cable 25-feet long (including the embedded length).

Concrete coring:

Four 3/2-in. diameter holes, each 3-feet long, through the abutment wall per each interior girder; one 2-in. diameter hole, 0.5-foot long, through the web of the girder, per each interior girder.

Anchorage:

Grouting of the abutment wall holes; four holes, each 3-feet long, per each interior girder.

Estimated cost

\$ 1,067.00 per each interior girder.

(c) T-Beam Connection to Pier Cap (Figure 1)

Assumptions

Restrainer:

3/4-in. diameter cable restrainers (ASTM A603); one cable per each interior girder; each cable 40-feet long.

Concrete coring:

One 3-in. diameter hole through 3-feet wide pier cap in each bay; one 2-in. diameter hole, 1-foot long, through the web of each interior girder; two 2-in. diameter holes, each 3-feet long, through the diaphragms per each interior girder.

Anchorage:

Two steel bearing plates, each 1.5 in. by 6 in. by 8 in., per each hole drilled through the pier cap.

Estimated cost

\$ 443.00 per each interior girder, when coring the diaphragms is not required.

\$ 755.00 per each interior girder, when coring the diaphragms is required.

(d) T-Beam Connection to Abutment Wall (Figure 3)

Assumptions

Restrainer:

3/4-in. diameter cable restrainers (ASTM A603); one cable per each interior girder; each cable 25-feet long (including the embedded length).

Concrete coring:

Two 3/2-in. diameter holes, each 3-feet long, through the abutment wall, per each interior girder; one 2-in. diameter hole, 1-foot long, through the web of the girder, per each interior girder.

Anchorage:

Grouting of the abutment wall holes; two holes, each 3-feet long, per each interior girder.

Estimated cost

\$ 573.00 per each interior girder.

(e) Steel Girder Connection to Pier Cap (Figure 2)

Assumptions

Restrainer:

3/4-in. diameter cable restrainers (ASTM A603); four cables per each interior girder; total cable length 100 ft.

Concrete coring:

One 4-in. diameter hole through a 3-feet wide pier cap in each bay.

Anchorage:

Two steel bearing plates, each 2 in. by 8 in. by 8 in., per each hole drilled through the pier cap; four steel angles (L 8 x 4 x 3/4), each 13-in. long, per each interior girder; two steel bearing bars (R = 7/4 in.), each 8-in. long, per each interior girder.

Estimated cost

\$ 1,508.00 per each interior girder.

(f) Steel girder Connection to Abutment Wall (Figure 4)

Assumptions

Restrainer:

3/4-in. diameter cable restrainers (ASTM A603); four cables per each interior girder; total cable length 55 ft. (including the embedded length).

Concrete coring:

Four 3/2-in. diameter holes, each 3-feet long, through the abutment wall per each interior girder.

Anchorage:

Grouting of the abutment wall holes; four abutment holes, each 3-feet long, per each interior girder; four steel angles (L 8 x 4 x 3/4), each 13-in. long, per each interior girder; two steel bearing bars (R = 7/4 in.), each 8-in. long, per each interior girder.

Estimated cost

\$ 1,824.00 per each interior girder.

LONGITUDINAL RESTRAINERS (MID-SPAN HINGES)

(a) Box-Girder Mid-Span Hinge Restraining (Figure 5)

Assumptions

Restrainer:

3/4-in. diameter cable restrainers (ASTM A603); seven cables, each 12-feet long, per each restraining unit.

Concrete coring:

Two 6-in. diameter holes, each 3-feet long, through the hinge diaphragms, per each restraining unit.

Diaphragm Strengthening:

Two reinforced concrete diaphragm bolsters, each on one side of the hinge diaphragms, full width of the bay, per each restraining unit.

Anchorage:

Two steel bearing plates, each 2 in. by 10 in. by 10 in., per two holes drilled through the diaphragms, per each restraining unit.

Access Opening:

Two access openings, each on one side of hinge diaphragms, per each restraining unit.

Access Closing:

Two access closings, each on one side of the hinge diaphragms, per each restraining unit.

Estimated cost

\$ 4,467.00 per each restraining unit, when an access opening is not required.

\$ 5,897.00 per each restraining unit, when an access opening is required, but an access closing is not required (e.g., access from the soffit).

\$ 7,457.00 per each restraining unit, when both an access opening and access closing are required.

Note: Typically, one restraining unit is used in each exterior cell, and every other interior cell is restrained symmetrically.

(b) T-Beam Mid-Span Hinge Restraining (Figure 6)

Assumptions

Restrainer:

3/4-in. diameter cable restrainers (ASTM A603); four cables, each 40-feet long, per each line of interior girders.

Concrete coring:

Four 4-in. diameter holes, each 3-feet long, two holes through the hinge diaphragms and two holes through the cross beam, per each line of interior girders; two 2-in. diameter holes, each 1-foot long, through the webs of the interior girders, per each line of interior girders.

Estimated cost

\$ 1,576.00 per each line of interior girders.

(c) Steel Girder Mid-Span Hinge Restraining (Figure 8)

Assumptions

Restrainer:

3/4-in. diameter rod restrainers; two rods, each 3-feet long, per each line of interior girders.

Header Strengthening:

Four channel braces (C7x12.25), each 2-feet long, per each line of interior girders; eight connection plates, each 0.5 in. by 6.5 in. by 8 in., per each line of interior girders.

Estimated cost

\$ 756.00 per each line of interior girders.

Note: This retrofit scheme also requires retrofitting the exterior girders. The cost of retrofitting each line of exterior girders is half of cost of retrofitting each line of interior girders.

TRANSVERSE BEARING RESTRAINERS (MID-SPAN HINGES)

(a) Box-Girder, and T-Beam, Mid-Span Hinge Restraining (Figures 5 and 6)

Assumptions

Restrainer:

3-in. diameter double-extra strong steel pipe filled with concrete; one pipe, each 2.5-feet long, per each restraining unit.

Concrete coring:

One 3.75-in. diameter hole, 2.75-feet long, through the hinge diaphragms, per each restraining unit.

Core Closing:

One steel retaining plate, 1/4 in. by 9 in. by 9 in., per one hole drilled through the diaphragms, per each restraining unit.

Estimated cost

\$ 421.00 per each restraining unit.

Note: Typically, when concrete shear keys do not exist, one restraining unit is used in each cell. Typically, when concrete shear keys exist, one restraining unit is used in each exterior cell, and every other interior cell is restrained symmetrically.

(b) Steel Girder Mid-Span Hinge Restraining (Figure 9)

Assumptions

Restrainer:

Steel plates; two plates, each 1.5 in. by 2 in. by 7 in., per each line of girders.

Anchorage:

One plate, 1.5 in. by 16.25 in. by 21 in., per each line of girders.

Estimated cost

\$ 714.00 per each line of girders.

RETROFITTING SEISMICALLY VULNERABLE BEARINGS

(a) Vulnerable Steel Expansion Bearings (Figure 11)

Assumptions

New Bearing:

One standard elastomeric bearing, 2-in. thick, 6-in. long, and 16-in. wide, replacing a steel bearing under the longitudinal steel stringer.

Concrete Work:

New reinforced concrete cap, and dowels, to adjust the height.

Superstructure Raising:

Jacking and falsework.

Estimated cost

\$ 767.00 per each vulnerable bearing. Add **\$ 1,000.00** for jacking and falsework of each girder, when superstructure jacking is required.

Note: The bearing replacement costs are based on a lump sum cost (\$23,000.00), reported in California, for replacing 30 vulnerable bearings. (22) That cost is in close agreement with the cost of installing a 1-foot high concrete cap under the girder and 2-foot high concrete shear key between the girders, given \$1000.00 per each cubic yard of concrete. The superstructure raising cost is based on a lump sum cost of \$172,000.00, reported in California, for jacking approximately 170 longitudinal stringers, and falsework. (22)

(b) Vulnerable Steel Fixed Bearings (Figure 12)

Assumptions

New Bearing:

Same bearing under the longitudinal steel stringer.

Concrete Work:

Embedding the existing bearing with concrete, 1-foot wide, 1.5-feet long, and 1-foot high; installing shear key between flanges, 6-feet wide, 1.5-feet long, and 2-feet high.

Superstructure Raising:

Not required.

Estimated cost

\$ 722.00 per each vulnerable bearing.

BASE ISOLATION

(a) Base Isolation Bearings (Figure 13)

Assumptions

Bearing:

Lead-rubber bearings (natural rubber); 350 sq.in. in area and 9 in. to 10 in. in height.

Bearing Installation:

Installation of the sole plate, masonry plate, keeper plates, etc.

Superstructure Raising:

Jacking and falsework.

Estimated cost

\$ 4,182.00 per each base isolation bearing installed. Add **\$ 1,000.00** for jacking and falsework of each girder.

Note: The superstructure raising cost is based on a lump sum cost of \$172,000.00, reported in California, for jacking approximately 170 longitudinal stringers, and falsework (22).

CHAPTER 4

DEVELOPMENT OF AN INDEX FOR RETROFIT PRIORITIZATION

By

K. Babaei, N. Hawkins, E. Henley,¹ A. Emter²

This chapter describes a mathematical model developed to produce an index by which WSDOT bridges at the network level can be prioritized systematically for seismic retrofitting. A preliminary form of the model was developed and subsequently reviewed by a panel of experts. Appendix A describes the preliminary model. Based on the comments offered by the panel, as shown in Appendix B, the preliminary model was modified and submitted to the WSDOT Bridge and Structures Office for its review. The WSDOT Bridge and Structures Office tested and calibrated the model. Below, the final form of the model is presented.

FORM OF THE MODEL

The general form of the model is

$$I = \{A\} \times \{C\}$$

in which

I = Priority index; I increases as priority increases.

A = Factor representing criticality of the route carried by the bridge, criticality of the utility lines carried by the bridge, criticality of the route crossed by the bridge, and criticality of the bridge as a public asset; A increases as criticality increases.

C = Factor representing vulnerability of the bridge to seismic failure; C increases as vulnerability increases .

¹Bridge Technology Development Engineer, WSDOT

²Bridge Engineer-4, WSDOT

Description of Criticality Factor, A

$$A = \begin{aligned} & [(RN_{\text{carry}}) (DL_{\text{carry}} \times N_{\text{carry}})] + \\ & [UT_{\text{carry}}] + \\ & (2/3) [(RN_{\text{cross}}) (DL_{\text{cross}} \times N_{\text{cross}})] + \\ & (1/4) [(ADT_{\text{carry}}/30,000) (L)]^{0.25} \end{aligned}$$

in which

RN_{carry} = Factor representing the nature of the route carried by the bridge.

RN_{carry} = 1.0; interstate route, principal artery, or confirmed emergency route
0.8; all other routes

DL_{carry} = Factor representing criticality of detour length for the route carried by the bridge;

DL_{carry} = 1.00; when detour length > 10 miles
0.80; when detour length is 3 to 10 miles
0.75; when detour length < 3 miles

N_{carry} = Factor representing criticality of detour for the route carried by the bridge because of traffic congestion; minimum 1.

$$N_{\text{carry}} = [ADT_{\text{carry}} / 30,000]^{0.25}$$

ADT_{carry} = Average daily traffic of the route carried by the bridge.

UT_{carry} = Factor representing utility lines carried by the bridge.

UT_{carry} = 1; bridge carrying a confirmed essential utility line.
0; all other bridges

RN_{cross} = Factor representing the nature of the route crossed by the bridge.

RN_{cross} = 1.0; confirmed emergency route
0.8; all other routes
0.0; no route under the bridge

DL_{cross} = Factor representing criticality of detour length for the route crossed by the bridge;

DL_{cross} = 1.0; when detour length > 10 miles
0.80; when detour length is 3 to 10 miles
0.75; when detour length < 3 miles

N_{cross} = Factor representing criticality of detour for the route crossed by the bridge because of traffic congestion; minimum 1.

$$N_{cross} = [ADT_{cross} / 30,000]^{0.25}$$

ADT_{cross} = Average daily traffic of the route crossed by the bridge.

$DL_{cross} \times N_{cross} = 1$, when

$RN_{cross} = 0.8$ (i.e., "all other routes")

This is because currently, the detour length and traffic volume for a route crossed by the bridge are generally not available, unless the route is an emergency route. The term $DL_{cross} \times N_{cross} = 1$ represents a typical condition for "all other routes".

L = Length of the bridge in ft.

Description of Vulnerability Factor, C

$$C = 0.17 [(a) (K)] [SV]$$

in which

a = Velocity-related peak ground acceleration coefficient mapped in Figure 14 (10% probability of being exceeded in 50 years, Reference 20).

K = Factor adjusting "a" to the remaining service period of the bridge based on the WSDOT's 20-Year Bridge Preservation Plan (i.e., to determine ground acceleration coefficient with 10% of probability of being exceeded within the remaining exposure period of the bridge).

The remaining service period of a bridge falls within one of the three categories shown below based on the WSDOT's 20-Year Bridge Preservation Plan.

Category 1 No plans for replacement or rehabilitation within 20 years.

Category 2 Bridge is identified for replacement or rehabilitation in the 20-Year Bridge Preservation Plan.

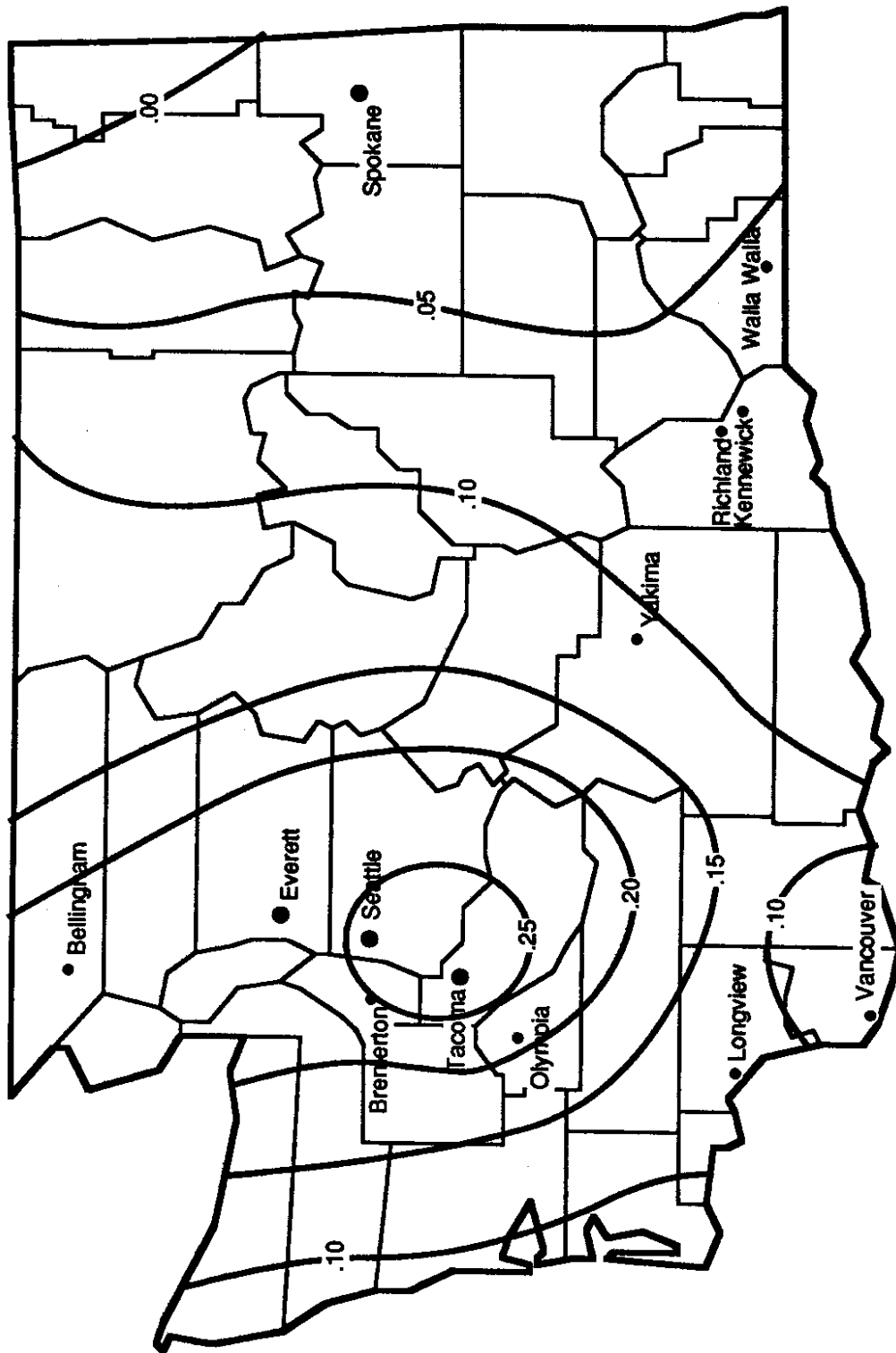

Figure 14. Velocity-rated Acceleration Coefficient Map Of Washington (Ref. 20)

Category 3 Bridge is scheduled or included in the 1991-1993 priority array for replacement or rehabilitation within 8 years. Bridges in this category are excluded from this prioritization model.

Values of K suggested based on the calculations of this work (presented in the last section of this chapter titled Probabilistic Estimate of Peak Acceleration Based on the Remaining Service Life of Structure) are:

K = 1.00; for Category 1
0.86; for Category 2

The value of K for Category 1 was conservatively selected to correspond to 50 years exposure period. The value of K for Category 2 was conservatively selected to correspond to 35 years exposure period. This is because many bridges in Category 2 will probably remain under service beyond the next 20 years time period.

SV = Factor representing seismic structural vulnerability.

"SV" increases as the seismic structural vulnerability increases. "SV" is zero for bridges that meet current seismic design standard criteria. WSDOT is currently conducting a review of bridge construction details to evaluate the seismic reliability of the total bridge structure, including superstructure, substructure, foundation, and soil conditions to determine "SV" factor for each individual bridge.

RANGE OF CRITICALITY FACTOR "A" AND PRIORITY INDEX "I"

Criticality factor, A, can be as high as 5.75, when

- * route carried by the bridge is an interstate route, principal artery, or confirmed emergency route,
- * detour length for the route carried by the bridge is 10 miles or more,
- * ADT of the route carried by the bridge is 100,000,
- * bridge carries a confirmed essential utility line,
- * route crossed by the bridge is a confirmed emergency route,
- * detour length for the route crossed by the bridge is 10 miles or more,
- * ADT of the route crossed by the bridge is 100,000, and
- * bridge length is 3,000 ft.

Criticality factor, A, can be as low as 1.26, when

- * route carried by the bridge is an ordinary route,
- * detour length for the route carried by the bridge is less than three miles,
- * ADT of the route carried by the bridge is 5,000,
- * bridge does not carry a confirmed essential utility line,
- * there is no route under the bridge, and
- * bridge length is 300 ft.

Priority index I ($I = A \times C$) shall not exceed 100

PROBABILISTIC ESTIMATE OF PEAK ACCELERATION BASED ON THE REMAINING SERVICE LIFE OF STRUCTURE

Algermissen and Perkins (Reference 23, pages 29 and 30) state that calculations of extreme probability accelerations for different return periods show the following approximate rule-of-thumb applies.

$$a_1 / a_2 = (T_1 / T_2)^{0.43} \quad (\text{Equation 1})$$

where

a_1 and a_2 are peak accelerations at a particular site for return periods T_1 and T_2 .

Although Equation 1 is for ground acceleration, for prioritization purpose the same empirical relation may be assumed for velocity-related ground acceleration recommended for the modification of WSDOT seismic design procedures (Figure 14).

An alternative form of Equation 1 is

$$a_1 = a_2 (T_1 / T_2)^{0.43}, \text{ or} \quad (\text{Equation 2})$$

$$a_1 = a_2 (K)$$

in that a_1 can be assumed as peak ground acceleration corresponding to an exposure period equal to the remaining life of the structure and with 90% probability of non-exceedence, and a_2 can be assumed as peak ground acceleration mapped (i.e., 90% probability of non-exceedence in 50 years exposure period). Then T_1 will be return period corresponding to a_1 , and T_2 will be return period corresponding to a_2 (i.e. 475 years). Finally, K, or the coefficient that modifies the peak acceleration mapped, considering the remaining service life, will be $(T_1 / T_2)^{0.43}$.

On the other hand the relation between return period, period of exposure, and extreme probability of non-exceedence is (Reference 23, page 7)

$$\ln [F_{\max, t(a)}] = -t / [R_{y(a)}] \quad (\text{Equation 3})$$

where

$F_{\max, t(a)}$ = Extreme probability of non-exceedence of peak ground acceleration,

t = Exposure period, and

$R_{y(a)}$ = Return period

Equation 3 can alternatively be written as

$$R_{y(a)} = -t / \ln [F_{\max, t(a)}] \quad (\text{Equation 4})$$

Using Equation 4, return period is calculated for various exposure periods, and for the extreme probability of non-exceedence of 90%, as follows.

<u>Exposure Period, years</u>	<u>Return Period, years</u>
50	475
45	427
40	380
35	332
30	285
25	237
20	190
15	142
10	95
5	47

Having various values of return period shown above, the coefficient of modification K (see Equation 2) can be found for various exposure periods using the following relation.

$$K = (T_1 / T_2)^{0.43} \quad (\text{Equation 5})$$

Where T_1 is a selected return period, and T_2 is return period for peak acceleration mapped, or 475 years. The values of K corresponding to various exposure periods (or remaining life of the structure) are listed below.

<u>Exposure Period, years</u>	<u>Acceleration Modification Coefficient, K</u>
50	1.00
45	0.96
40	0.91
35	0.86
30	0.80
25	0.74
20	0.67
15	0.59
10	0.50
5	0.37

ACKNOWLEDGMENT

This work was sponsored by the Washington State Department of Transportation (WSDOT), in cooperation with the Federal Highway Administration, and was conducted by the Washington State Transportation Center (TRAC) at the University of Washington.

Neil M. Hawkins, formerly Professor of Civil Engineering, University of Washington, and currently Head of Civil Engineering, University of Illinois at Urbana-Champaign; and Khossrow Babaei, formerly Senior Research Engineer, Washington State Transportation Center, and currently a consultant, were principal investigators for the project. WSDOT Technical monitor for the project was Ed Henley, Bridge Technology Development Engineer, Bridge and Structures Branch.

Ed Henley and Al Emter, WSDOT Bridge Engineer - 4, tested and calibrated the systematic procedure developed in Chapter 4 to prioritize bridges for seismic retrofitting.

REFERENCES

1. Algermissen, S.T., "An Introduction to the Seismicity of the United States," Earthquake Engineering Research Institute Publication, 1983.
2. Murphy, L.M., "San Fernando, California Earthquake of February 9, 1971," U.S. Department of Commerce, National Oceanic and Atmospheric Administration, 1973.
3. "The San Fernando Earthquake of February 9, 1971, and Public Policy," Report of Special Subcommittee of the Committee on Seismic Safety California Legislature, July 1972.
4. Imbsen, R.A., "Highway Structure Damage Caused by the Trinidad Offshore, California Earthquake of November 8, 1980," Federal Highway Administration, Report No. FHWA/RD-82/017, December 1981.
5. Astaneh, A., Bertero, V.V., Bolt, B.A., Mahin, S.A., Moehle, J.P., and Seed, R.B., "Preliminary Report on the Seismological and Engineering Aspects of the October 17, 1989 Loma Prieta Earthquake," Earthquake Engineering Research Center, University of California at Berkeley, Report No. UCB/EERC-89/14, October 1989.
6. Priestley, M.J. Nigel, Seible, F., and Chal, Y.H., "Collapse of the Cypress Viaduct," Department of Applied Mechanics and Engineering Sciences, University of California, San Diego, La Jolla, California.
7. "Design of Lead-Rubber Isolation Bearings for Bridges," Dynamic Isolation Systems Inc., Berkeley, California, January 1988.
8. Maroney, B., California Department of Transportation, Oral Communications, April 1990.
9. Billings, I.J., and Kirkland, D.K., "Base Isolation of Bridges in New Zealand," Proceedings of Second Joint U.S.-New Zealand Workshop on "Seismic Resistance of Highway Bridges," Sponsored in part by National Science Foundation, San Diego, California, 1985.
10. Applied Technology Council, "Seismic Retrofitting Guidelines for Highway Bridges," Federal Highway Administration, Report No. FHWA/RD-83/007, 1983.
11. Mancarti, G.D., "New Concepts in Earthquake Retrofitting of Highway Bridges," Paper Presented at the 6th Northwest Bridge Engineer Seminar, October 6-8, 1981, Updated to September 1984.
12. Mellon, S., "Seismic Report, Post Earthquake Investigation Team, Palm Spring, California Earthquake, July 8, 1986," California Department of Transportation.

13. Degenkolb, O.H., "Retrofitting of Existing Highway Bridges Subject to Seismic Loading - Practical Considerations," Proceedings of a Workshop on "Earthquake Resistance of Highway Bridges," Sponsored by National Science Foundation, 1979.
14. Robinson, R.R., Longinow, A., and Albert, D.S., "Seismic Retrofit Measures for Highway Bridges; Volume 2, Design Manual," Federal Highway Administration, Report No. FHWA-TS-79-217, 1979.
15. Buckle, I.C., "Development and Application of Base Isolation and Passive Energy Dissipation: A World Overview," Proceedings of a Seminar and Workshop on "Base Isolation and Passive Energy Dissipation," Sponsored by National Science Foundation, San Francisco, California, 1986.
16. Roeder, C.W., and Stanton, J.F., "Performance of Elastomeric Bearings," National Cooperative Highway Research Program, Report No. 298, 1987.
17. Kelly, T., and Buckle, I., "Design Guidelines for Lead-Filled Elastomeric Bearings for Use in Seismic Isolation of Bridges," American Concrete Institute, Publication SP-94, "Joint Sealing and Bearing Systems; Volume 2," 1986.
18. Stuart, C.R., "Seismic Retrofitting of Highway Bridges in New Zealand," Proceedings of Second Joint U.S.-New Zealand Workshop on "Seismic Resistance of Highway Bridges," Sponsored in part by National Science Foundation, San Diego, California, 1985.
19. Mayes, R.L., "Conventional and Seismic Isolation Retrofit Techniques for Bridges," Paper Presented at Building Seismic Safety Council Workshop on "Abatement of Seismic Hazards to Lifelines," Federal Management Agency, November 1986.
20. Higgins, J.D., Frigaszy, R.J., and Beard, L.D., "Seismic Zonation for Highway Bridge Design," Washington State Department of Transportation, Report No. WA-RD 172.1, 1988.
21. California Department of Transportation's earthquake retrofit materials submitted by James E. Roberts, Chief Division of Structures, California Department of Transportation, to C.S., Gloyd, Bridge and Structures Engineer, Washington State Department of Transportation, July 8, 1987.
22. Pomeroy, E.G., "Sierra Point Overhead Seismic Isolation Retrofit," Proceedings of a Seminar and Workshop on "Base Isolation and Passive Energy Dissipation," Sponsored by National Science Foundation, San Francisco, California, March, 1988.
23. Algermissen, S.T., and Perkins, D.M., "A Probabilistic Estimate of Maximum Acceleration in Rock in the Contiguous United States," United States Department of Interior, Geological Survey, Open-File Report 76-416, 1976.

APPENDIX A
PRELIMINARY FORM OF THE BRIDGE SEISMIC RETROFIT
PRIORITIZATION MODEL

UNIVERSITY OF WASHINGTON
SEATTLE, WASHINGTON 98195

*College of Engineering, FH-10
Office of the Dean*

March 7, 1990

Dr. Nigel Priestley
Department of AMES, R-011
University of California, San Diego
La Jolla, CA 92093

Dear Dr. Priestley:

The Washington State Department of Transportation is responsible for a state highway system that contains over 3,000 bridges and two important lifelines; Interstates 5 and 90 and their branches. Washington State is also an active seismic area with the AASHTO Bridge Code placing much of the state west of the Cascade Mountains in Zone 3 and that east of those mountains in Zone 2. Those zonings are, however, based primarily on a historic record which is only about 140 years long. Recent geophysical and geologic evidence suggests that there can be larger earthquakes than those normally associated with Zone 3 due to the existence of a subduction zone West of the Olympic Mountains. As a consequence, earthquakes with magnitudes of 8.5 or more are possible in that zone with a 300 to 500 year return period.

The foregoing perception of an increased seismic risk in Washington State and the relatively poor performance of many highway bridges in recent U.S. earthquakes, has prompted the Washington State Department of Transportation, (WSDOT), to initiate a bridge retrofit program. Since the monies available for that program are considerably less than the total need, WSDOT has retained the Washington State Transportation Research Center, (TRAC), to develop a strategy for prioritizing the bridges to be retrofitted and identifying appropriate retrofit methods. TRAC research engineer Khoss Babaei and myself are co-principal investigators for that project and we have developed a proposed strategy for that retrofit program. Since that strategy has major policy implications for the State of Washington, we would like it reviewed for significant omissions and inconsistencies by several knowledgeable individuals before formally recommending it to WSDOT for a bridge retrofit program that will start this Summer.

In view of your experience in earthquake engineering, and particularly its application to bridges, I solicit your help in reviewing our proposed strategy. If you are unable to make that review personally, I ask that you have some knowledgeable individual within your group make that assessment. This same letter is being sent to eight individuals who have a broad range of interests and a wide geographic distribution. Those individuals are:

Dr. Vitelmo Bertero, Director, Center for Earthquake Engineering, University of California Berkeley; Dr. Ian Buckle, Deputy Director, National Center for Earthquake Engineering, State University of New York at Buffalo;
Dr. John Clark, ABKJ Engineers, Seattle, WA; Dr. Kazuhiko Kawashima, Public Works Research Institute, Tsukuba, Japan; Dr. David I. McLean, Department of

Telephone: (206) 543-0340

Page 2
March 7, 1990

Civil Engineering, Washington State University, Pullman WA, and Dr. Nigel Priestley, Department of AMES, University of California, San Diego; Dr. Masanobu Shinozuka, Department of Civil Engineering, Princeton University; and Dr. Colin Brown, Department of Civil Engineering, University of Washington.

A copy of our proposed strategy for prioritizing bridges to be retrofitted is enclosed. Since the eastern part of the State of Washington is in seismic Zone 2 and the western part is in Zone 3 it is necessary for us to have a strategy that might identify a bridge in Zone 2 as having a high priority for retrofit if it is an essential facility and is of a construction likely to perform poorly in an earthquake. Further, we are constrained to have a strategy that allows WSDOT engineers to work only from data that are readily available from existing plans to perform the necessary work for prioritization. That constraint means that at this stage our strategy cannot take into account detailed structural or geotechnical information. We must expedite the prioritization procedure so that the WSDOT can start retrofitting bridges this summer. Our prioritization system is one based on gross bridge characteristics and not details. That is, of course, a weakness but is reasonable if our scheme is envisaged as a first cut, and not an in-depth evaluation system. That in-depth evaluation is a logical second phase to our work.

So you can better understand the geophysical/strong motion situation in Washington State, I enclose copies of:

(1) the velocity-related acceleration coefficient map for Washington State developed by a consultant for WSDOT, and,

(2) the plate tectonics in Washington State from the Washington State Division of Geology and Earth Resources Circular No. 85.

Thank you in advance for your assistance. If possible I would like to receive your comments by March 31 at the latest.

Sincerely,



Neil M. Hawkins
Associate Dean for Research,
Facilities, and External Affairs
FAX 206-545-0666

NMH:mg
cc: K. Babaei
F: BRIDGE-SEISMIC
PERS RES

DRAFT**BRIDGE SEISMIC RETROFIT PLANNING PROGRAM****"Development of an Index for Retrofit Prioritization"****Draft Summary Report for Task 3
(Subject to Revision)**

by

**Khossrow Babaei
Senior Research Engineer
Washington State Transportation Center**

and

**Neil M. Hawkins
Professor of Civil Engineering
University of Washington****Washington State Transportation Center (TRAC)
University of Washington, JE-10
The Corbet Building, Suite 204
4507 University Way N.E.
Seattle, Washington 98105**

Prepared for

**Washington State Department of Transportation
Olympia, Washington**

March 1990

INTRODUCTION

This report describes a mathematical model developed to produce an index by which WSDOT bridges at the network level can be prioritized systematically for seismic retrofitting. This report is the product of the Task 3 of the WSDOT research project "Bridge Seismic Retrofit Planning Program".

FORM OF THE MODEL

The general form of the model is

$$I = \{A + B\} \{C\}$$

in which

I = Priority index; I increases as priority increases.

A = Factor representing the criticality of the route carried by the bridge and the route crossed by the bridge; A increases as criticality increases.

B = Factor representing the worth of the bridge to the public and to the highway agency; B increases as worth increases.

C = Factor representing the vulnerability of the bridge to seismic failure; C increases as vulnerability increases.

Description of Criticality Factor, A

$$A = 10 [(RN_{carry}) (DL_{carry}) + (UT_{carry}) + (RN_{cross}) (DL_{cross})]$$

in which

RN_{carry} = Factor representing the nature of the route carried by the bridge.

RN_{carry} = 1; all routes
 2; interstate, or defense route
 3; interstate and defense route
 5; emergency route

If no information on the nature of the route carried is available, $RN_{carry} = 1$.

DL_{carry} = Detour length in miles for the route carried by the bridge; maximum 10 miles, and minimum 1 mile.

If no information on the detour length is available, $DL_{carry} = 5$ miles for urban bridges, and 10 miles for rural bridges.

UT_{carry} = Factor representing utility lines carried by the bridge

UT_{carry} = 0; all bridges
50; bridge carrying utility lines

If no information on UT_{carry} is available, $UT_{carry} = 0$.

RN_{cross} = Factor representing the nature of the route crossed by the bridge.

RN_{cross} = 0; no route under the bridge
1; all routes
5; emergency route

If no information on the nature of the route crossed is available, $RN_{cross} = 1$.

DL_{cross} = Detour length in miles for the route under the bridge; maximum 10 miles, and minimum 1 mile.

If no information on the detour length is available, $DL_{cross} = 5$ miles for urban routes, and 10 miles for rural routes.

Description of Worth Factor, B

$$B = 1/10 [(ADT) (REP.COST) / (RET.COST)]^{0.5}$$

in which

ADT = Average daily traffic of the route carried by the bridge

REP.COST = Cost of replacing the segment of the bridge vulnerable to collapse in dollars (ignore the effect of local ground acceleration, and consider possibility for a severe earthquake).

RTE.COST = Cost of retrofitting the bridge in dollars (rough estimate of superstructure retrofitting only for prioritization purpose).

Description of Vulnerability Factor, C

$$C = [(a) (K)]^{1.5} [SD]$$

in which

a = Peak ground acceleration coefficient mapped (10% probability of being exceeded in 50 years).

K = Factor adjusting "a" to the remaining service life of the bridge (i.e., to determine ground acceleration coefficient with 10% of probability of being exceeded within the remaining service life of the bridge).

Values of K suggested based on the calculations of this work (see Appendix) are

K =

- 1.0; when remaining life is more than 40 years.
- 0.91; when remaining life is between 40 and 30 years
- 0.80; when remaining life is between 30 and 20 years
- 0.67; when remaining life is between 20 and 10 years
- 0.50; when remaining life is less than 10 years

SD = Factor representing seismic structural deficiency.

Four levels of superstructure deficiency and corresponding SD values are suggested for prioritization purpose as follows.

SD =

- 4; continuous structure with a mid-span hinge.
- 3; Multi-span structure with all spans simply supported.
- 2; continuous structure with simple supports at abutments.
- 1; single span with simple supports.

RANGE OF PRIORITY INDEX, I

Criticality factor, A, can be as high as 1,500 when

- * route carried by the bridge is both emergency and utility route,
- * detour length for the bridge is 10 miles or more,
- * route crossed by the bridge is an emergency route, and
- * detour length for the route crossed by the bridge is 10 miles or more.

Worth factor, B, can be as high as 400 when

- * average daily traffic on the bridge is 100,000, and
- * the ratio of replacement cost to retrofit cost is 160.

Seismic vulnerability factor, C, can be as high as 0.500 when

- * the coefficient of ground acceleration is 0.25,
- * the remaining life of the bridge is 40 years or more, and
- * the structure has hinge in a span.

Priority index, I, can be as high as [(A=1,500) + (B=400)] (C=0.500) = 950

EXAMPLE PROBLEM ONE (BASE CONDITION)

The bridge to be examined is located in the City of Seattle and it carries an ordinary route. The detour length is four miles. The bridge crosses an ordinary route with a detour length of 3 miles.

The average daily traffic on the bridge is 5,000. The structure is a three span T beam (all spans simply supported) and it is 180 foot long and 35 foot wide. The bridge was built in 1955. The local ground acceleration coefficient is 0.20.

Step 1. Determine Criticality Factor. A

$RN_{carry} = 1$
Bridge carries an ordinary route.

$DL_{carry} = 4$
Detour length is 4 miles.

$UT_{carry} = 0$
Bridge does not carry utility lines.

$RN_{cross} = 1$
Bridge crosses an ordinary route.

$DL_{cross} = 3$
Detour length is 3 miles.

$A = 10 [(1)(4) + (0) + (1)(3)] = 70$
 $A = 5\%$ of Max. Criticality

Step 2. Determine Worth Factor. B

$ADT = 5,000$

$REP.COST = (180 \text{ ft} \times 35 \text{ ft}) (\$70/\text{sq.ft}) = \$441,000$
Assuming that all three spans can fall off in a severe earthquake.

$RET.COST = (\$800 \times 5 \times 4 + \$500 \times 5 \times 2) = \$21,000$
Assuming the bridge has five interior girders in each span, which would be restrained with 3/4 in. diameter cables; cost of tying a girder to pier is \$800 and to abutment \$500.

$B = 1/10 [(5,000) (441,000) / (21,000)]^{0.5} = 32$
 $B = 8\%$ of Max. Worth

Step 3. Determine Seismic Vulnerability Factor. C

$a = 0.20$

$K = 0.91$

K corresponds to the remaining service life of 35 years; the bridge has served 35 years and the typical bridge life is 70 years, thus the remaining service life is 35 years.

$$SD = 3$$

SD corresponds to a structure with all spans simply supported.

$$C = [(0.20)(0.91)]^{1.5} [3] = 0.233$$

C = 47% of Max. Vulnerability

Step 4. Determine Priority Index, I

$$I = \{A + B\} \{C\} = \{70 + 32\} \{0.233\} = 24$$

I = 3% of Max. Priority

EXAMPLE 2

Example one bridge carries an emergency route.

$$A = 230$$

(15% of Max. Criticality)

$$B = 32$$

(8% of Max. Worth)

$$C = 0.233$$

(47% of Max. Vulnerability)

$$I = 61$$

(6% of Max. Priority)

EXAMPLE 3

Example one bridge carries an emergency route and crosses an emergency route.

$$A = 350$$

(23% of Max. Criticality)

$$B = 32$$

(8% of Max. Worth)

$$C = 0.233$$

(47% of Max. Vulnerability)

$$I = 89$$

(9% of Max. Priority)

EXAMPLE 4

Example one bridge carries utility lines.

$$A = 570$$

(38% of Max. Criticality)

$$B = 32$$

(8% of Max. Worth)

$$C = 0.233$$

(47% of Max. Vulnerability)

$$I = 140$$

(15% of Max. Priority)

EXAMPLE 5

Example one bridge carries an emergency route, carries utility lines, and crosses an emergency route.

A = 850	(57% of Max. Criticality)
B = 32	(8% of Max. Worth)
C = 0.233	(47% of Max. Vulnerability)
I = 206	(22% of Max. Priority)

EXAMPLE 6

Example one bridge has an ADT of 100,000.

A = 70	(5% of Max. Criticality)
B = 145	(36% of Max. Worth)
C = 0.233	(47% of Max. Vulnerability)
I = 50	(5% of Max. Priority)

EXAMPLE 7

Example one bridge carries an emergency route, carries utility lines, crosses an emergency route, and has an ADT of 100,000.

A = 850	(57% of Max. Criticality)
B = 145	(36% of Max. Worth)
C = 0.233	(47% of Max. Vulnerability)
I = 232	(24% of Max. Priority)

EXAMPLE 8

Example one bridge carries an emergency route with a detour length of 10 miles, carries utility lines, crosses an emergency route with a detour length of 10 miles, and has an ADT of 100,000.

A = 1500	(100% of Max. Criticality)
B = 145	(36% of Max. Worth)
C = 0.233	(47% of Max. Vulnerability)
I = 383	(40% of Max. Priority)

EXAMPLE 9

Example one bridge is located in Yakima (coefficient of acceleration = 0.10), carries an emergency route, carries utility lines, crosses an emergency route, has an ADT of 50,000, is a continuous structure with a mid-span hinge, and has 45 years of remaining service life (assume the same replacement and retrofit cost).

A = 850	(57% of Max. Criticality)
B = 102	(26% of Max. Worth)
C = 0.126	(25% of Max. Vulnerability)
I = 120	(13% of Max. Priority)

EXAMPLE 10

Example one bridge is located in Spokane, (coefficient of acceleration = 0.05), carries an emergency route, carries utility lines, crosses an emergency route, has an ADT of 50,000, is a continuous structure with a mid-span hinge, and has 45 years of remaining service life (assume the same replacement and retrofit cost).

A = 850	(57% of Max. Criticality)
B = 102	(26% of Max. Worth)
C = 0.044	(9% of Max. Vulnerability)
I = 42	(4% of Max. Priority)

SENSITIVITY OF FACTORS CONTRIBUTING TO PRIORITY INDEX, I

Nature of route

Priority index increases on the average by about 6.5 times as RN_{carry} increase from 1 to 5, UT_{carry} increases from 0 to 50, and RN_{cross} increases from 1 to 5 (i.e., regular bridge crossing a regular route versus an emergency/utility bridge crossing an emergency route).

Bridge Traffic

Priority index increases on the average by about 2 times as ADT increases from 1,000 to 100,000.

Ground Acceleration

Priority index increases by about 11 times as "a" (coefficient of peak ground acceleration) increase from 0.05 to 0.25.

Remaining Service Life

Priority index increases by about 3 times as the remaining service life of the bridge increases from 10 years to 40 years or more.

Structural Deficiency

Priority index increases by 4 times as SD increase from 1 to 4 (i.e., from single span bridge simply supported to continuous bridge with mid-span hinge).

APPENDIX

Probabilistic Estimate of Peak Acceleration Based on the Remaining Service life of Structure

Algermissen and Perkins (Reference 1, pages 29 and 30) state that calculations of extreme probability accelerations for different return periods show the following approximate rule-of-thumb applies.

$$a_1 / a_2 = (T_1 / T_2)^{0.43} \quad \text{(Equation 1)}$$

where

a_1 and a_2 are peak accelerations at a particular site for return periods T_1 and T_2 .

An alternative form of Equation 1 is

$$a_1 = a_2 (T_1 / T_2)^{0.43}, \text{ or} \quad \text{(Equation 2)}$$

$$a_1 = a_2 (K)$$

in that a_1 can be assumed as peak ground acceleration corresponding to an exposure period equal to the remaining life of the structure and with 90% probability of non-exceedence, and a_2 can be assumed as peak ground acceleration mapped (i.e., 90% probability of non-exceedence in 50 years exposure period). Then T_1 will be return period corresponding to a_1 , and T_2 will be return period corresponding to a_2 (i.e. 475 years). Finally, K , or the coefficient that modifies the peak acceleration mapped, considering the remaining service life, will be $(T_1 / T_2)^{0.43}$.

On the other hand the relation between return period, period of exposure, and extreme probability of non-exceedence is (Reference 1, page 7)

$$\ln [F_{\max, t(a)}] = -t / [R_{y(a)}] \quad \text{(Equation 3)}$$

where

$F_{\max, t(a)}$ = Extreme probability of non-exceedence of peak ground acceleration,

t = Exposure period, and

$R_{y(a)}$ = Return period

Equation 3 can alternatively be written as

$$R_{y(a)} = -t / \ln [F_{\max, t(a)}] \quad (\text{Equation 4})$$

Using Equation 4, return period is calculated for various exposure periods, and for the extreme probability of non-exceedence of 90%, as follows.

<u>Exposure Period, years</u>	<u>Return Period, years</u>
50	475
45	427
40	380
35	332
30	285
25	237
20	190
15	142
10	95
5	47

Having various values of return period shown above, the coefficient of modification of K (see Equation 2) can be found for various exposure periods using the following relation.

$$K = (T_1 / T_2)^{0.43} \quad (\text{Equation 5})$$

Where T_1 is a selected return period, and T_2 is return period for peak acceleration mapped, or 475 years. The values of K corresponding to various exposure periods (or remaining life of the structure) are listed below.

<u>Exposure Period, years</u>	<u>Acceleration Modification Coefficient, K</u>
50	1.00
45	0.96
40	0.91
35	0.86
30	0.80
25	0.74
20	0.67
15	0.59
10	0.50
5	0.37

REFERENCES

1. **Algermissen, S.T., and Perkins, D.M., "A Probabilistic Estimate of Maximum Acceleration in Rock in the Contiguous United States", United States Department of Interior, Geological Survey, Open-File Report 76-416, 1976**

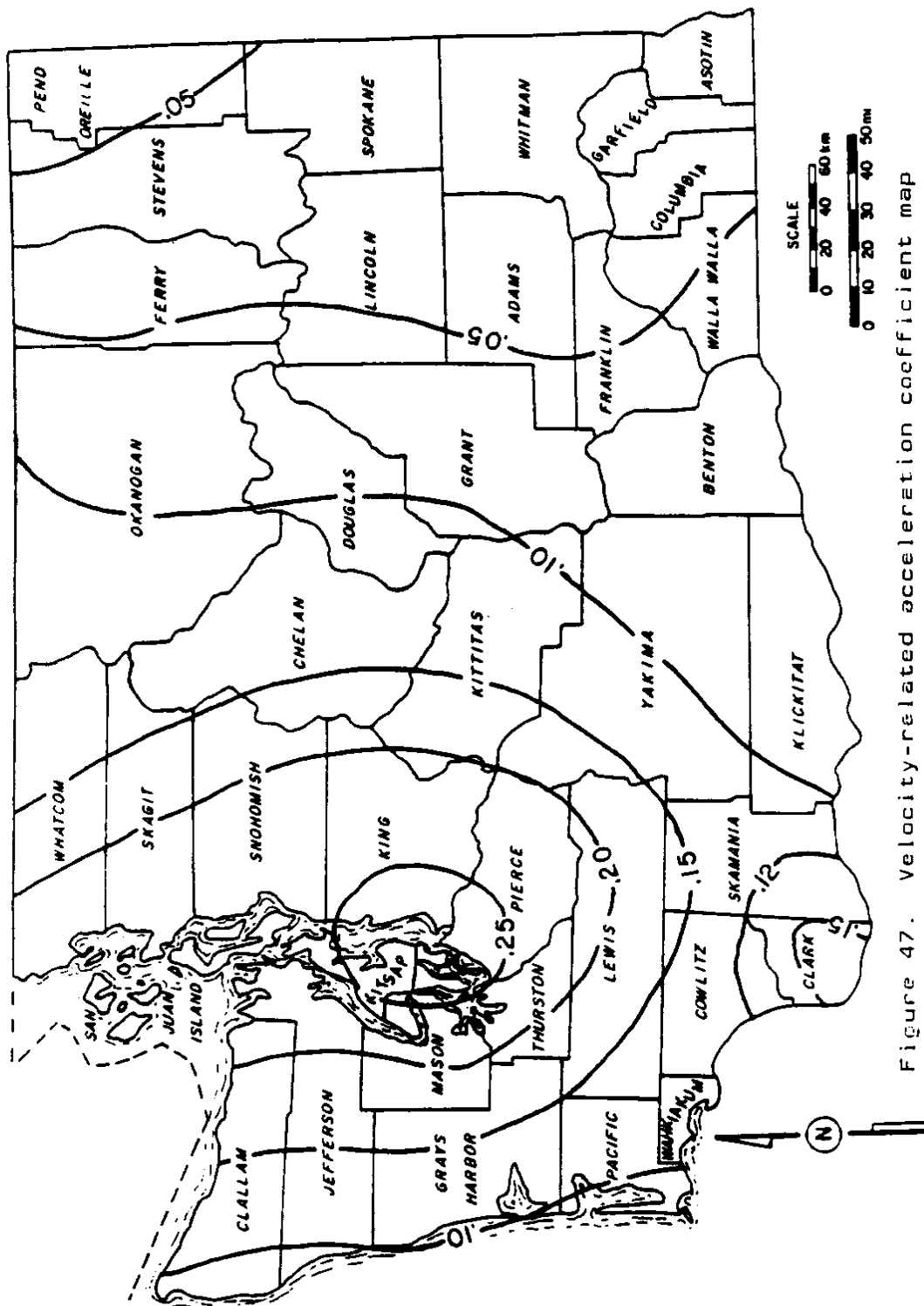

Figure 47. Velocity-related acceleration coefficient map of Washington.

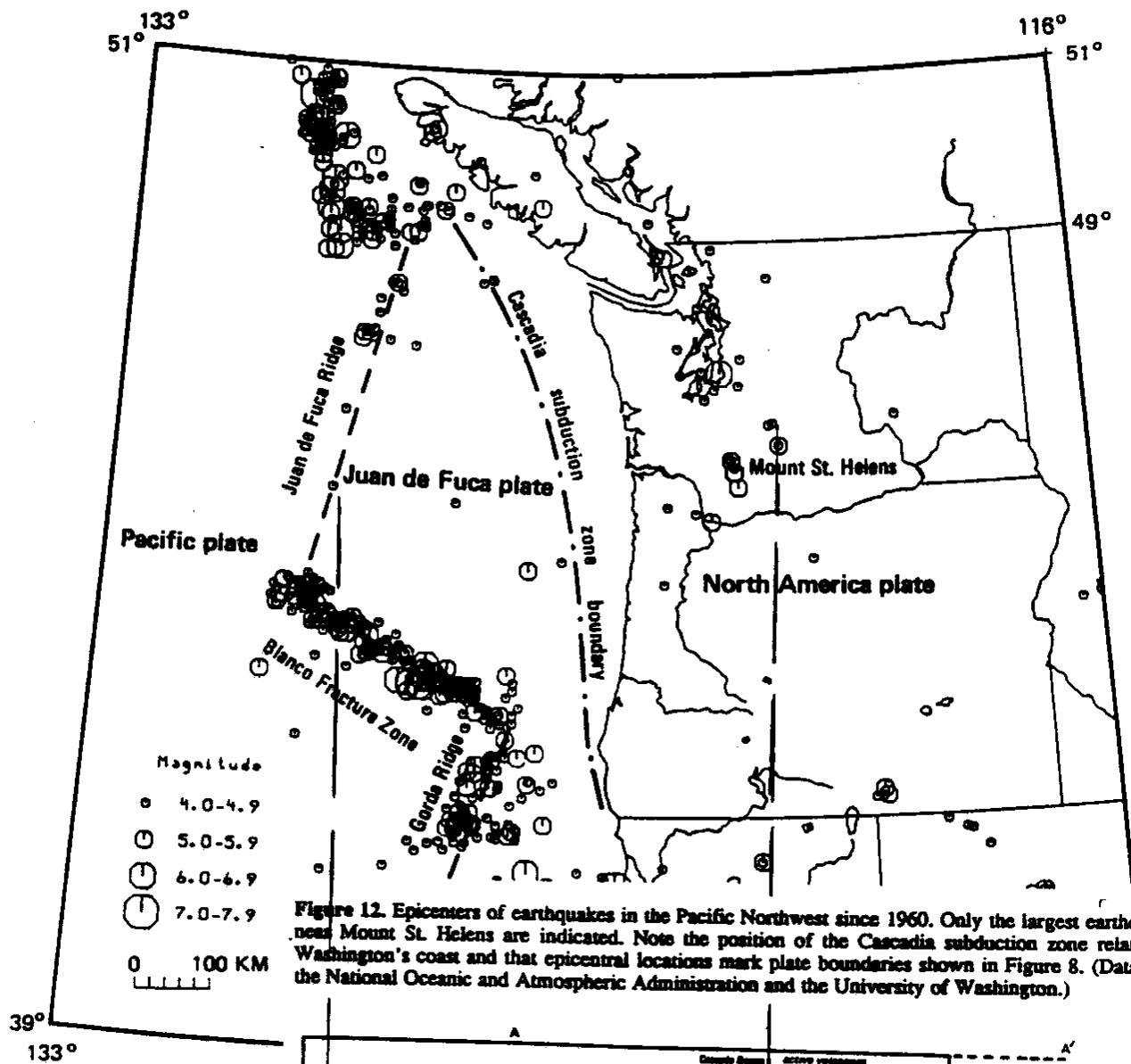

Figure 12. Epicenters of earthquakes in the Pacific Northwest since 1960. Only the largest earthquakes near Mount St. Helens are indicated. Note the position of the Cascadia subduction zone relative to Washington's coast and that epicentral locations mark plate boundaries shown in Figure 8. (Data from the National Oceanic and Atmospheric Administration and the University of Washington.)

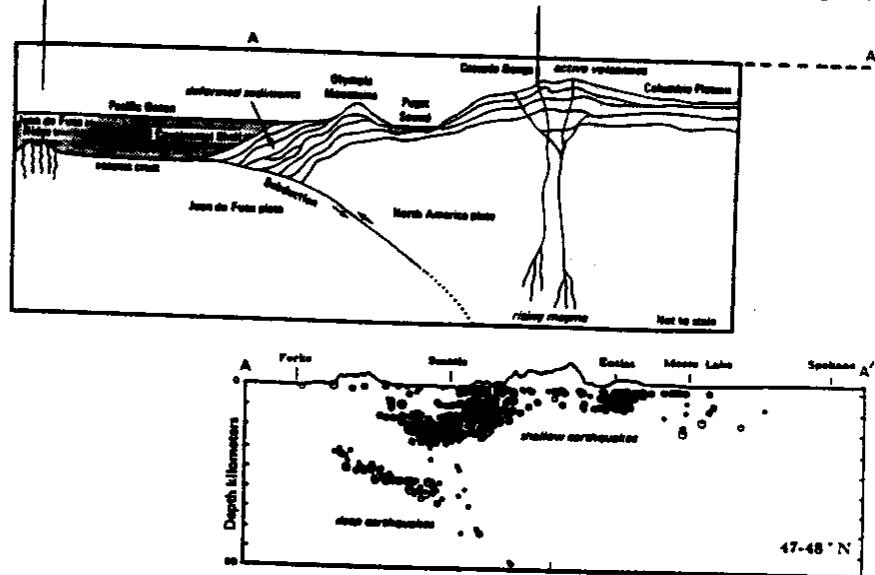

Figure 11. Cross sections of Washington showing plate convergence (top figure) and earthquake hypocenter locations. Some major topographic features and underlying geologic structures of Washington are shown diagrammatically in the upper figure. In the lower figure, selected hypocenters of earthquakes that occurred in 1982 through 1986 between latitudes 47° and 48°N are projected onto a vertical plane that generally corresponds to the diagram in the upper figure. Because of the great number of shallow earthquakes that occurred between 1982 and 1986, only hypocenters of those having magnitudes equal to or greater than 1.8 are shown in the lower figure. Below 30 km, hypocenters of all earthquakes having magnitudes of 1.0 or greater that occurred during this period are shown. The distribution of deep earthquakes indicates the slope of the zone of subduction. In the lower figure there is a vertical exaggeration of 2 to 1 below sea level; this causes the illusion that the subducting Juan de Fuca plate dips more steeply than it actually does. Topography indicated on the lower figure has a vertical exaggeration of 12 to 1.

APPENDIX B

**PANEL'S REVIEW COMMENTS ON THE PRELIMINARY FORM
OF THE BRIDGE SEISMIC RETROFIT PRIORITIZATION MODEL**

UNIVERSITY OF CALIFORNIA, SAN DIEGO

BERKELEY • DAVIS • IRVINE • LOS ANGELES • RIVERSIDE • SAN DIEGO • SAN FRANCISCO



SANTA BARBARA • SANTA CRUZ

DEPARTMENT OF APPLIED MECHANICS AND
ENGINEERING SCIENCES, MAIL CODE R-011

LA JOLLA, CALIFORNIA 92093-0411

March 27, 1990

RECEIVED

APR 02 1990

COLLEGE OF ENGINEERING
ASSOCIATE DEAN FOR RESEARCH

Professor Neil M. Hawkins
Associate Dean for Research,
Facilities and External Affairs
College of Engineering FH-10
University of Washington
Seattle, WA 98195

RE: Bridge Seismic Retrofit Planning Program

Dear Neil:

Thank you for the opportunity to review the Draft Summary Report on the above topic by Babael and yourself. As you know, my experience in bridge retrofit is more in the 'nuts-and-bolts' end of the problem than in the prioritization which seems full of subjective decisions more suited to Colin Brown's 'Fuzzy Set' analyses and other analytical approaches which leave me feeling equally fuzzy.

Nevertheless, I will humbly offer my comments, which will be more in the nature of questions (i.e. have you adequately considered . . . etc. etc).

1. Does the velocity-related acceleration coefficient map appended to your report [Fig.47 (sic)] adequately represent Washington seismicity, considering the subduction potential? Your letter notes the possibility of M8.5 earthquakes with a 300-500 year return period. This corresponds rather closely (in terms of annual probability of occurrence) to the design earthquake with 10% probability in 50 years. I would have thought that the peak acceleration contours resulting from such an earthquake would bear little resemblance to those in Fig.47. In particular, the PGA's recorded in the vicinity of Valparaiso in the M7.9 earthquake of 1985 comes to mind: These can be characterized by PGA's exceeding 0.5g over a wide range. Subduction earthquakes tend to provide a rather large area of effectively uniform ground acceleration, with attenuation not being noticeable until maybe more than 100 km from the epicenter.
2. It is not clear from your report whether retrofit measures include column retrofit, or just restrainer retrofit, although the formulation of the priority index I seems related to the latter. If this is the case I think the formulation is unwise, and I suspect that the Cypress Viaduct victims would agree, were they able to.

Page 2
 Professor Neil Hawkins
 March 27, 1990

3. Although I have no quarrel with the form of the basic model

$$\text{i.e. } I = (A + B) \{C\}$$

Some of the details worry me:

CRITICALITY FACTOR A

- (a) The criticality is dominated by utility lines. The lack of subdivision here (i.e. 0 or 50) seems to make the precision of $RN_{\times DL}$, which can never exceed UT , somewhat unwarranted. Are all cases of utility carriage equally critical?
- (b) It would seem to me that inner city detour length would be more critical than rural detour. That is, a 2 mile detour of the I-5 through Seattle would probably be worse than a 5 mile detour of the I-5 in a rural location because of the congestion. Strictly, the detour should, I suppose, be time, rather than distance, based.
- (c) I don't understand why RN_{cross} does not have the same subdivisions as RN_{carry} . It seems to me that dropping a bridge onto the I-5 has more serious consequences than dropping it onto a farmer's access route.
- (d) However, I believe that carried traffic is more important than crossed traffic. A collapsed bridge carrying the I-5 will affect traffic for months. A collapsed bridge crossing the I-5 will affect (I-5) traffic for only days. Therefore the product $(RN_{\text{cross}}) (DL_{\text{cross}})$ should have a reduced weighting factor appended (maybe 0.5?).

WORTH FACTOR B

- (e) The worth factor, though strictly consistent, does not take into account the public preference for killing people in a large number of small incidents rather than a small number of major incidents. A 3 span and a 50 span bridge of similar structural form carrying the same traffic will have the same B value. However, if you want to avoid the current CALTRANS problems, it would be a good idea to look at your multispan bridges with high potential for large death tolls first.
- (f) Should an interstate bridge carrying 100,000 vehicles/day be given a higher I value than an 'all routes' bridge with the same volume of traffic? It seems to be doubly weighted in this case.

Page 3
Professor Neil Hawkins
March 27, 1990

- g) The index I is very insensitive to the ADT. This seems surprising to me, since deaths and cost of detour will be directly proportional to ADT.

VULNERABILITY FACTOR

- (h) As noted above, I believe the "a" values are probably too low. For prioritization this is less important than the contours of a, which, again as noted above, I suspect to be questionable if a large subduction earthquake is possible.
- (i) K seems ok.
- (j) SD worries me. It doesn't seem to be based on sufficient structural information. Is a 5 span bridge with one midspan hinge really more vulnerable than the same bridge with all spans simply supported? Are the support conditions irrelevant? Are the soils conditions irrelevant? I believe that SD should reflect
- (i) height of piers.
 - (ii) redundancy of bent support [i.e. 3 columns better than 1].
 - (iii) potential for soils amplification or liquefaction.
 - (iv) date of construction [current design details are presumably better than pre 1970].
 - (v) superstructure material [steel bridges are much lighter and seem to have a better track record in earthquakes].
 - (vi) articulation [already considered in your SD values].
 - (vii) double decker [the press would crucify WSDOT if one collapsed].

By implication, a single span or multispan bridge with portal type supports has an SD = 0. Although a lower value is appropriate, particularly for 1 to 3 span bridges, I would be reluctant to say there is no risk, particularly for multispan bridges.

Page 4
Professor Neil Hawkins
March 27, 1990

I hope these comments are of some value. Please contact me if you like amplification of any points. I presume that you have reviewed the CALTRANS prioritization scheme. If not, you should contact Jim Gates or Brian Maroney.

Kind regards

Yours sincerely,



M.J. Nigel Priestley
Professor of Structural Engineering

M JNP:jw

**ANDERSEN
BJORNSTAD
KANE
JACOBS, INC.**
CONSULTING ENGINEERS

RECEIVED
MAR 28 1990
COLLEGE OF ENGINEERING
ASSOCIATE DEAN FOR RESEARCH

March 27, 1990

250 WEST HARRISON
SEATTLE, WASHINGTON 98119
TELEPHONE: (206) 205-1195

Dr. Neil M. Hawkins
Associate Dean for Research, Facilities, and External Affairs
College of Engineering, FH-10
University of Washington
Seattle, Washington 98195

Re: Bridge Seismic Retrofit Prioritization Scheme

Dear Dr. Hawkins:

I have reviewed your scheme for prioritization of highway bridges for seismic retrofit and offer the following comments:

General

The procedure appears to be straightforward, simple to apply, and requires no data or skills beyond that of an average highway engineer in the District (except perhaps the cost factors). The procedure allows for a wide range of values, thus more clearly selecting those structures in most need of retrofit.

The section illustrating the sensitivity of the prioritization value to each of the component factors is helpful to both the user and the administrator. I believe that you have extracted the most pertinent factors to be considered in the decision process.

Description of Worth Factor, B

It would seem that there should also be consideration given to the ADT of the route crossed (for an overcrossing) especially if the detour on the route crossed is long.

Description of Vulnerability Factor, C

The structural deficiency factor, SD, should be 3 for a multiple span structure with any one span simply supported since lost of any span renders the bridge inoperable.

There would be a large difference in vulnerability between bridges designed in accordance with the Guide Specifications for Seismic Design of Highway Bridges, AASHTO 1983 and those designed according to older specifications, It may be that this procedure would only be applied to bridges designed under the older specifications.

N. Hawkins
March 27, 1990
Page Two

Example Problem One (Base Condition)

The current map showing expected peak acceleration coefficients in use by WSDOT shows the coefficient for the Seattle area to be 0.25 instead of 0.20 (See Fig 47 attached. This is not critical to understanding the application of the procedure.)

You are to be commended for producing a useful tool for decision makers faced with this difficult question.

If you have any questions concerning this review please call me.

Sincerely,

ANDERSEN BJORNSTAD KANE JACOBS, INC.

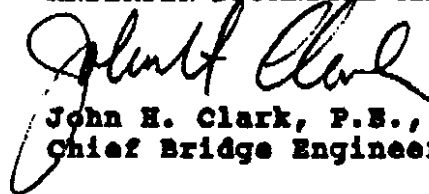

John H. Clark, P.E., Ph.D.
Chief Bridge Engineer

JHC:SLP

Washington State University

Department of Civil and Environmental Engineering Pullman, Washington 99164-2910
Telephone: 509-335-2576 / Facsimile: 509-335-7632

March 27, 1990

Dr. Neil M. Hawkins
Associate Dean for Research,
Facilities, and External Affairs
College of Engineering
371 Loew Hall, FH-10
University of Washington
Seattle, WA 98195

Dear Dr. Hawkins:

In response to your request for review of your proposed bridge retrofit strategy, I offer the following comments.

- (1) What is the basis/background for the proposed priority index model? Is the model based upon previous work? If not, additional information on the reasoning behind the form of the model would be insightful.
- (2) With regard to "Criticality Factor, A":
 - Detour length is an important factor. However, a 10 mile urban detour is not equivalent to a 10 mile rural detour in terms of time delay, congestion, etc. Equally as important as the detour length is the ability of the detour to accommodate increased traffic volume and the load ratings on any bridges of the detour.
 - The proposed model gives equal weighting to a bridge with utilities ($UT_{\text{carry}} = 50$) and to a bridge over an emergency route with a 10 mile detour ($RN_{\text{carry}} \times DL_{\text{carry}} = 50$). With only a few exceptions, I don't think that the presence of utilities should be this significant.
- (3) With regard to "Worth Factor, B":
 - The worth factor incorporates both the daily volume for the bridge (use importance of the bridge) and the replacement cost relative to the retrofit cost of the bridge. I would offer that these are two separate factors.
 - Planned future nonseismic rehabilitation (resulting in possible economies in the seismic retrofit) and the time required to replace or repair a damaged bridge (a replacement cost) should also impact the priority index.

- (4) With regard to "Vulnerability Factor, C":
- To be consistent with ATC recommendations, the acceleration coefficient should be based on effective ground acceleration rather than peak ground acceleration.
 - The proposed structural deficiency factor seems overly simplistic. It does not take into account different types of in-span hinges and expansion joints, provided support lengths, nor nature of bearings.
- (5) The sensitivities (weightings) of the factors are given as approximately:
- (a) Nature of route: can increase I by 6.5 times for the given parameter variation.
 - (b) Bridge traffic: can increase I by 2 times.
 - (c) Ground acceleration: can increase I by 11 times.
 - (d) Remaining service life: can increase I by 3 times.
 - (e) Structural deficiency: can increase I by 4 times.

For comparison purposes, the Seismic Priority Rating System given in the FHWA "Seismic Design and Retrofit Manual for Highway Bridges" proposes the following factors:

- (f) Seismic vulnerability: Factor ranges from 0 to 10. The factor is to be chosen as the greater of the superstructure or substructure vulnerability. This factor approximately corresponds to the structural deficiency factor (e) above, except that the structural deficiency factor does not consider substructure deficiencies.
- (g) Seismicity: equals 25 times the acceleration coefficient. Factor ranges from 0 to 10. Approximately corresponds to (c) above.
- (h) Importance: includes social/survival and security/defense requirements, level of traffic, size of bridge, and the age of the bridge. Factor ranges from 0 to 10. Approximately corresponds to (a), (b), and (d) above.

It is recommended in the manual that equal weighting be given to the three factors. The sensitivities of these factors on the seismic index are approximately:

- an increase in the index of 1.6 to 9 times as the vulnerability factor increases from 0 to 10 (depends on the values of the seismicity and importance factors). For the region of practical interest, the increase is in the range of 1.6 to 4. This is approximately the same as the sensitivity of the structural deficiency factor incorporated into the Hawkins/Babaei proposed model.
- an increase in the index of 1.2 to 5 as the ground acceleration coefficient increases from 0.05 to 0.25, with the region of practical interest being in the range of 1.2 to 2. Thus, greater weight is given to the ground acceleration with the Hawkins/Babaei proposed model than with the FHWA proposed model.

- an increase in the index of 1.6 to 9 times as the importance factor increases from 0 to 10, with the region of practical interest being in the range of 1.6 to 4. It would appear that the FWHA proposed model is less sensitive to importance factor than is the Hawkins/Babaei proposed model.

(6) It is noted in your cover letter that, while the proposed model does not take into account detailed structural or geotechnical information, the model is a first-cut evaluation system. Any strategy for prioritizing bridges to be retrofitted must include comprehensive consideration of the response of the total bridge structure, including superstructure, substructure, and soil conditions. The problems of retrofitting only part of a bridge were illustrated in the damage to the highway bridges in the Loma Preita Earthquake, several of which had undergone superstructure retrofit only. Noting this, I would hope that your proposed model would be presented as being incomplete, and that development of the in-depth evaluation system would be a necessary second step prior to the implementation of your prioritization model.

I thank you for giving me the opportunity to respond to your proposal. Please contact me if you have any questions about my review.

Sincerely,



David I. McLean

JA 298 (*) 15:05

トホ*777*199* ヲセカ



**PUBLIC WORKS
RESEARCH INSTITUTE**
MINISTRY OF CONSTRUCTION
GOVERNMENT OF JAPAN
1, ASAMI, TSUKUBA-SHI, IBARAKI-KEN, 305 JAPAN
TELEPHONE:(0298)64-2211/FAX:(0298)64-2840
TELEX:3652-874 PWRIMC J

Dr. Neil M. Hawkins
Associate Dean for Research, Facilities,
and External Affairs
University of Washington
Seattle, Washington 98195
U.S.A.
Fax: 206-545-0666

Dear Professor Hawkins :

This letter is to correspond to your letter of March 7, 1990 on your proposal to bridge seismic retrofit planning program prepared for the Washington State Department of Transportation.

Before making comments on your proposal, let me have some explanations on the Japanese situation, which will assist you to interpret my comment. Seismic retrofitting is important but hard jobs for Japanese road bridges, too. However the reason why we require seismic retrofit for road bridges in Japan may not be the same with yours. Seismic design was introduced in design of Japanese road bridges in 1926, i.e., 3 years later than the Kanto Earthquake. Since 1926, seismic design has been made with use of elastic lateral force equivalent with 20 - 30 % of gravity force and with allowable stress approach. Important point in the past seismic damage is that the damage pattern has been gradually changed as the seismic design provisions have been gradually improved and amended in an effort to minimize the damage. In rather old time, the foundations were likely to suffer movement, tilting and even overturning, and this, in turn, resulted complete failure of deck. Because soft soil deposit exists widely in Japan, failure of weak soil had been more contributing factors for bridge damage than structural response. However this type of the damage decreases although it still occurs when ground failure associated with soil liquefaction develops. Failure of RC piers and bearing supports are more frequently observed in recent earthquakes.

2/2

Through such damage situations, we have made seismic inspection four times since 1971. In the last inspection in 1985, about 40,000 road bridges with span length more than 15 m were inspected. About 11,000 bridges were found to require seismic retrofit, and the cost required for the retrofit was evaluated as about 700 billion yen. This is now being made in the 5 year road construction project. Seismic inspection method is outlined in a paper enclosed.

I have been discussing with Mr. James Gates and Mr. Ray Zelinski, CALTRANS, on the seismic design and seismic retrofit of California road bridge. Although I do not know the seismic design practice in the State of Washington, I anticipate the situation may be somehow similar with the CALTRANS. Based on such assumption, following are my understanding and comments on your proposal :

- 1) No matter how it is urged, prioritization without enough structural information based only on available data on desk may be meaningless to prepare against an event with magnitude as large as 8.5. In-depth evaluation of seismic vulnerability from structural characteristics point of view seems essential. In my understanding it is the lesson from the Loma Prieta Earthquake that those bridge with close natural period with the predominant period of ground motion and with natural period of soils and those constructed on soft soils were vulnerable against seismic action. Therefore, for installing cable restrainer which is less expensive measures, the proposed method for prioritization seems all right, but for much expensive measures, more detailed inspection on the current situation of bridge seems required.
- 2) As a measure for seismic retrofit, cable restrainer seems to be considered in Example Problem One. However it seems the lesson obtained from the Loma Prieta Earthquake that the restrainer is quite effective only when the substructure (pier and foundation) is strong/ductile enough to resist the seismic disturbances. Therefore, for those bridge which is critically important and have high probability to have larger structural response than their strength/ductility, critical evaluation on strength of substructure seems essential.
- 3) It is advised to propose to the Washington State Department of Transportation that the retrofit to prevent damage against M8.5 event is quite costly and requires quite long time. Strong administrative will and support for seismic retrofit as well as enough budget is quite important and essential.

I wish that the above comments are useful to stimulate your program on seismic inspection prioritization. Please allow for my delay in responding to your letter. If you have questions, please feel free to contact with me.

Sincerely,



Kazuniko Kawashima, Head
Earthquake Engineering Division
Public Works Research Institute

B-11