

Return to TRAC  
Director's Library

**Protocols for Evaluation of Upstream Passage  
of Juvenile Salmonids in an Experimental  
Culvert Test Bed**

WA-RD 614.1

Research Report  
May 2005



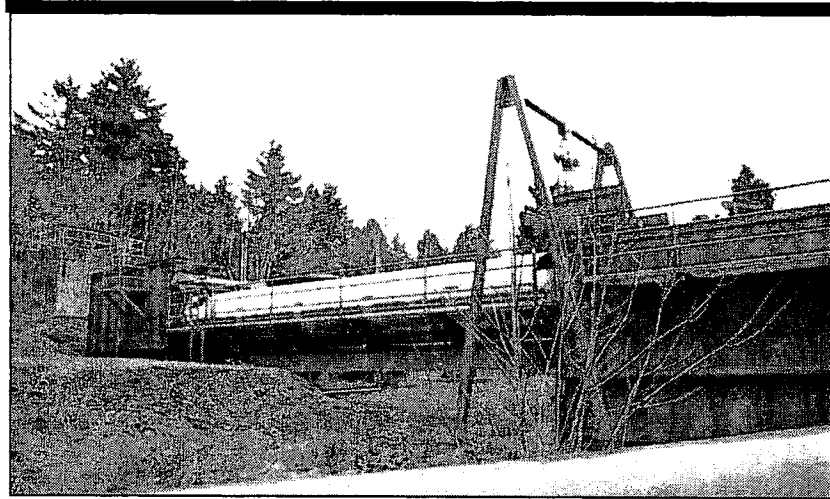
**Washington State  
Department of Transportation**

Washington State Transportation Commission  
Planning and Capital Program Management  
in cooperation with:  
U.S. DOT - Federal Highway Administration

---

# **Protocols for Evaluation of Upstream Passage of Juvenile Salmonids in an Experimental Culvert Test Bed**

---



## **FINAL REPORT**

W. Pearson, M. Richmond, G. Johnson,  
S. Sargeant, R. Mueller, V. Cullinan,  
Z. Deng, B. Dibrani, G. Guensch,  
C. May, L. O'Rourke, K. Sobocinski,  
and H. Tritico

May 2005

Prepared for  
the Washington State Department of Transportation  
under On-Call Agreement Y-9031, Task AA  
Battelle, Pacific Northwest Division  
of Battelle Memorial Institute

## Legal Notice

This report was prepared by Battelle Memorial Institute (Battelle) as an account of sponsored research activities. Neither Client nor Battelle nor any person action on behalf of either:

MAKES ANY WARRANTY OR REPRESENTATION, EXPRESS OR IMPLIED, with respect to the accuracy, completeness, or usefulness of the information contained in this report, or that the use of any information, apparatus, process, or composition disclosed in this report may not infringe privately owned rights; or

Assumes any liabilities with respect to the use of, or for damages resulting from the use of, any information, apparatus, process, or composition disclosed in this report.

Reference herein to any specific commercial product, process, or service by trade name, trademark, manufacture or otherwise, does not necessarily constitute or imply its endorsement, recommendation, or favoring by Battelle. The views and opinions of authors expressed herein do not necessarily state or reflect those of Battelle.

---

# **Protocols for Evaluation of Upstream Passage of Juvenile Salmonids in an Experimental Culvert Test Bed**

---

## **FINAL REPORT**

W. Pearson, M. Richmond, G. Johnson,  
S. Sargeant, R. Mueller, V. Cullinan,  
Z. Deng, B. Dibrani, G. Guensch,  
C. May, L. O'Rourke, K. Sobocinski,  
and H. Tritico

May 2005

Prepared for  
the Washington State Department of Transportation  
under On-Call Agreement Y-9031, Task AA

Battelle Memorial Institute  
Pacific Northwest Division  
Richland, Washington 99352

<sup>1</sup> Battelle Marine Sciences Laboratory, Sequim, Washington

<sup>2</sup> Battelle Pacific Northwest Division, Richland, Washington

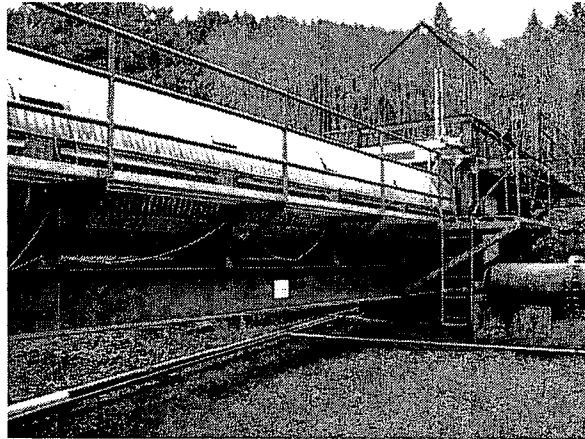
<sup>3</sup> Balance Hydrologics, Inc., Berkeley, California

## WSDOT Technical Report Standard Title Page

1. REPORT NO. <b>WA-RD 614.1</b>	2. GOVERNMENT ACCESSION NO. -----	3. RECIPIENTS CATALOG NO -----	
4. TITLE AND SUBTITLE <b>Protocols for Evaluation of Upstream Passage of Juvenile Salmonids in an Experimental Culvert Test Bed</b>		5. REPORT DATE <b>May 2005</b>	
		6. PERFORMING ORGANIZATION CODE -----	
7. AUTHOR(S) <b>Pearson, W. H. et al.</b>		8. PERFORMING ORGANIZATION REPORT NO. <b>PNWD-3525</b>	
9. PERFORMING ORGANIZATION NAME AND ADDRESS  <b>Battelle Memorial Institute Pacific Northwest Division P.O. Box 999 Richland, Washington 99352</b>		10. WORK UNIT NO. -----	
		11. CONTRACT OR GRANT NO. <b>On-Call Agreement Y-9031, Task AA</b>	
12. SPONSORING AGENCY NAME AND ADDRESS  -----		13. TYPE OF REPORT AND PERIOD COVERED -----	
		14. SPONSORING AGENCY CODE -----	
15. SUPPLEMENTARY NOTES <b>This study was conducted in cooperation with the U.S. Department of Transportation, Federal Highway Administration.</b>			
16. ABSTRACT <b>The Washington State Department of Transportation (WSDOT) and its partner agencies developed a research program to design new and retrofit culverts. The goal of this program is to identify culvert bed configurations, designs, and associated hydraulic conditions that allow successful movement of juvenile salmonids upstream, while safely passing water, sediment, and debris downstream. WSDOT in cooperation with the Washington Department of Fish and Wildlife (WDFW) constructed a culvert test bed at the WDFW's Skookumchuck Hatchery in western Washington State. Battelle conducted experiments to establish protocols for future research on bed conditions, culvert shape, etc. This technical report describes various protocols, such as time of day, duration of test, and density of test fish, and provides hydraulic and biological characterizations of a baseline culvert.</b>			
17. KEY WORDS <b>Culverts, culvert test bed, juvenile salmonid passage, culvert passage</b>		18. DISTRIBUTION STATEMENT -----	
19. SECURITY CLASSIF. (of this report)  <b>None</b>	20. SECURITY CLASSIF. (of this page)  <b>None</b>	21. NO. OF PAGES  <b>93</b>	22. PRICE  -----

## Summary

The Battelle Pacific Northwest Division is working with the Washington State Department of Transportation (WSDOT) and its partner agencies<sup>1</sup> on a research program to design new and retrofit culverts. The goal of this research program is to identify culvert bed configurations, designs, and associated hydraulic conditions that allow successful movement of juvenile salmonids upstream, while safely passing water, sediment, and debris downstream. To this end, WSDOT in cooperation with the Washington Department of Fish and Wildlife (WDFW) has established a culvert test bed (Figure S1) at the WDFW's Skookumchuck Hatchery in western Washington State.



**Figure S1.** Culvert Test Bed Photograph Showing Culvert and Headwater Tank.

The overall objectives of the culvert test bed (CTB) research program are to a) create a conceptual design; b) select a site; c) design, fabricate, install, and test the CTB; d) develop evaluation protocols for hydraulic and biological measurements; e) conduct tests at the CTB under various experimental conditions; and f) report results. Aligned with these six objectives, the CTB research program has six phases. Phases 1-3 have been completed and work is essentially complete on Phase 4 (Protocol Development). Phase 5 (Biological and Hydraulic Testing) and Phase 6 (Reporting) have been started. The program phases build upon one another and provide specific milestones for program management.

As part of Phases 4 and 5, this report provides data from the hydraulic and biological tests conducted in April/May 2003 and November 2004. Results from the leaping ability tests in December 2004 will be reported separately. The objectives of the research reported herein were to

1. Develop evaluation protocols that will be used in future tests of culvert types and bed configurations and assess:
  - a. Hydraulics: equipment, sampling locations, and data analysis

---

<sup>1</sup> Partner agencies include the Alaska Department of Fish and Game, Alaska Department of Transportation, the California Department of Transportation, the Federal Highway Administration, and the Oregon Department of Transportation.

- b. Biological: test fish, fish handling and retrieval, video monitoring, data analysis, and the following test conditions: time of day and shading; backwatering; tailwater (TW) pool depth; and fish density in the TW pool.
2. Provide hydraulic and biological characterizations of a "baseline culvert" (6 ft round corrugated culvert, 40 ft long, bare bed, and sloped 1.14%) as follows:
    - a. Obtain measurements of water velocity for the following CTB discharges: 1.0, 1.5, 2.0, 2.5, 3.0, 3.5, 4.0, 8.0, and 16.0 cubic feet per second (cfs).
    - b. Assess the relationship between fish passage success (defined in Section 2.2.1.4) and the following CTB discharges: 1.0, 1.5, 2.0, 2.5, 3.0, 3.5, 4.0 cfs
    - c. Determine the horizontal distribution of fish exiting the culvert into the headwater (HW) tank
    - d. Assess the relationship between fish passage success and hydraulic conditions.

#### Protocol Development

Protocol development is Phase 4 of the CTB research program. Protocols will ensure that results from various CTB tests are comparable. We developed protocols for the CTB for two main areas: hydraulic measurements and biological tests. The protocols address 24 variables covering CTB conditions, experimental design, fish handling, biological data, and physical data. The protocol results revealed test conditions shown to enhance upstream passage in the test bed. Key results include:

- trials at night rather than during the day;
- no shading;
- shallow tailwater pool depth (approximately 9 in);
- TW pool fish density between 1 and 2 fish/ft<sup>3</sup>.

Also, fish size and seasonality are clearly factors in passage success and needs to be incorporated into design of future experiments at the CTB.

#### Baseline Culvert Characterization

The characterization of the baseline culvert includes 1) hydraulic results, 2) biological results, and 3) data on the relationships between fish passage success and hydraulics. Hydraulic conditions, i.e., water velocities, were measured at 1, 1.5, 2, 2.5, 3.5, 4, 8, and 16 cfs. A summary of the hydraulic measurements and calculations at each flow rate measured is presented in the text.

In the biological characterization of the baseline culvert, passage success (PS) (number in HW tank divided by number released in TW tank) decreased from 16% at 1.0 cfs to 3% at 1.5 cfs and remained below 3% up to 3.5 cfs when it decreased to 0.5 %. The fish that did pass upstream successfully were generally observed on the far right side of the culvert (looking upstream). For fish exiting from the culvert into the HW tank, the data revealed that the horizontal distribution was skewed to the right (looking upstream).

We explored trends in the relationship between passage success and four hydraulic variables: mean velocity over the entire cross section; mean velocity in the RVZ; maximum velocity over the entire cross

section; and mean turbulence intensity in the RVZ. The correlation coefficients indicated the level of association between passage success (transformed using the arcsine of the square root) and four hydraulic variables; the correlations ranged from 26.4% to 75.3%. There was pronounced variability in the hydraulic data. For example, in a 10-sec time-series in the RVZ at 4 cfs, the mean stream-wise velocity was 1 fps and the RMS was 0.41 fps.

### Conclusions

The following conclusions are drawn from research in April/May 2003 and November 2004 at the culvert test bed for upstream passage of juvenile salmon:

1. The CTB facility is completely functional structurally, mechanically, hydraulically, and biologically.
2. The gantry positioning system can locate the acoustic Doppler velocimeter (ADV) to provide detailed water velocity data, from which turbulence intensity can be calculated.
3. The underwater and aerial video cameras in conjunction with infrared lighting at night can provide qualitative data on fish behavior in the tailwater tank, in the culvert barrel, and during entry to the headwater tank, although observing movement of small fish within the culvert is often difficult due to turbulent flow.
4. The procedures for hydraulic characterizations and fish passage tests are ready for use. Volitional trials with a shallow (approximately 9-inch) pool depth and a low-to-moderate fish density (1 to 2 fish/ft<sup>3</sup>) at night without additional lighting are appropriate for future experiments.
5. There are issues at the study design level that need to be addressed in future studies.
  - a. Because passage success varies with fish size and seasonal factors, fish size and seasonal factors will need to be taken into account in the design of future testing programs.
  - b. Specific values for pool depth and backwatering may need to be adjusted if baffles or other configurations change the hydraulic patterns that attract fish and enable passage.
6. For the baseline culvert configuration and the juvenile coho salmon tested in May 2003, preliminary data on the relationship between passage success and flow level showed a decreasing trend in passage success from 1.0 to 3.5 cfs, and that zero passage occurred at 4.0 cfs.
7. Analysis of video observations finds that the fish successfully reaching the upstream end of the culvert exit into the headwater tank predominantly on the right hand side looking upstream. This finding suggests that the juvenile salmon are using the low velocity - low turbulence zone on the right side of the culvert to accomplish passage.
8. There is pronounced variability of hydraulic conditions, e.g., water velocity, turbulence, in space and time. The determinants of fish passage success appear to more to do with the fine scale structure and dynamics of the hydraulics than with the overall or average hydraulic conditions. This situation reinforces the notion that understanding the interaction of the hydraulic conditions with fish behavior will be integral to understanding the determinants of fish passage success. The culvert test bed and its associated instrumentation are well positioned for such a task.



### Recommendations

Protocols describe the methods to be used consistently from test-to-test in future work (Table S1). Categories for the protocols include setup of the CTB, experimental design, fish handling, ancillary physical data, and fisheries data collection.

**Table S1.** Recommendations for Evaluation Protocols at the CTB. See Section 5 of the report for further explanation. TW refers to the tailwater tank; HW refers to the headwater tank.

<b>Category</b>	<b>Factor</b>	<b>Recommendation</b>
CTB Setup	Shade over TW and HW tanks	None
	Distance TW Bottom to Culvert Invert	Set at 9-10 inches; review for baffled systems
	Backwater	Backwater minimally into the culvert; review for baffled systems
	Hiding Structures in HW Tank	None
Experimental Design	Test Period (time of day)	Nighttime
	Duration (length of a test)	3 h, but reconsider tests all night
	Seasonality	Controls and treatments interwoven across time
	Control Tests	Periodically during a series of tests
	Fish Density in TW Tank	Between 1 and 2 fish/ft <sup>3</sup>
	Fish Size	Design yearly experimental program appropriately
	Sampling Unit	All fish in a single test
Fish Handling	Fish Feeding Regime	Feed 24 h before test and then do not feed until after the test
	Fish Holding	In net pens but separate from the facility's fish population
	Acclimation	No pre-test holding in the TW tank
	Counting (Pre-test)	Dual counts
	Retrieval	Dip nets
Fisheries Data	Fork Lengths	Measure at least 20 fish per test (if available) at end
	Counts (Post-test)	Retrieve fish in TW tank, culvert, and HW tank (in this order)
	Video Monitoring	Monitor video in real-time; every 10 min classify behavior
Physical Data	Staff Gages, Flow, and Manometer	Record TW and HW depths, approximate flow from meter (pre-culvert), and manometer measurements
	Turbidity	Observe at least one time per day
	Water Temperature	Record at least one time per test
	Dissolved Oxygen	Measure once each test in HW tank
	Light Intensity	Measure once each test in TW and HW tanks

## Acknowledgments

The following individuals were instrumental to this project: Rhonda Brooks, Leni Oman, Jon Peterson, Marty Pietz, Jim Schaffer, Jim Toohey, and Paul Wagner of the Washington Department of Transportation; Jim Dills, Rich Eltrich, Mary Evans, Tom Burns, and Pat Powers of the Washington Department of Fish and Wildlife; Harry Dunham of Montgomery-Watson-Harza Global, Inc.; Clint Banzet of Hi-Line Engineering and Fabrication; Mark Aldridge and Al Irvin of Baseline Construction, Inc.; and members of the Steering Committee from the Alaska Department of Fish and Wildlife, Alaska Department of Transportation, California Department of Fish and Game, California Department of Transportation, Federal Highway Administration, Oregon Department of Transportation, and U.S. Forest Service. We thank Matthew Mabey (ODOT), Mark Miles (ADOT), Marcin Whitman (CDFG) for reviewing July 2003 draft. We are grateful to Ken Bates (retired WDFW) for comments on the February 2005 draft report. We appreciate the internal Battelle reviews of report drafts by Blythe Barbo, Dennis Dauble, Dick Ecker, Marty Miller, and Terri Gilbride.

## Acronyms

ADV	acoustic Doppler velocimeter
cfs	cubic feet per second
CTB	culvert test bed
FL	fork length
HW	headwater
OZ	occupied zone
PS	passage success
RMS	root-mean-square
RVZ	reduced velocity zone
TW	tailwater
WDFW	Washington Department of Fish and Wildlife
WSDOT	Washington State Department of Transportation

## Contents

<b>LEGAL NOTICE</b>	<b>I</b>
<b>WSDOT TECHNICAL REPORT STANDARD TITLE PAGE</b>	<b>II</b>
<b>SUMMARY</b>	<b>I</b>
<b>ACKNOWLEDGMENTS</b>	<b>V</b>
<b>ACRONYMS</b>	<b>VI</b>
<b>CONTENTS</b>	<b>VII</b>
<b>FIGURES</b>	<b>IX</b>
<b>TABLES</b>	<b>XI</b>
<b>1.0 INTRODUCTION</b>	<b>1</b>
1.1 Report Objectives	3
1.2 Background and Need	4
1.3 CTB Site Description	5
1.4 Report Contents	8
<b>2.0 METHODS</b>	<b>9</b>
2.1 Hydraulic Measurements	9
2.1.1 Equipment	9
2.1.2 Sampling Locations	12
2.1.3 Data Analysis	16
2.2 Biological Tests	18
2.2.1 Test Fish	20
2.2.2 Fish Handling and Retrieval	20
2.2.3 Video Monitoring	21
2.2.4 Fish Passage Success Metric	23
<b>3.0 RESULTS</b>	<b>25</b>
3.1 Hydraulic Measurements	25
3.1.1 Water-Surface Profiles	25
3.1.2 Stream-wise Velocity and Turbulence Intensity	27
3.1.3 Vertical Profiles	34
3.1.4 Cross-Sectional Profiles	39
3.1.5 Longitudinal Profiles	40
3.1.6 Relationships between Hydraulic Parameters	43
3.2 Biological Tests	45
3.2.1 Protocol Development	45
3.2.1.1 Validation of Basic Methods, Including Net Pen	46

3.2.1.2	Time of Day and Shading	47
3.2.1.3	Backwatering	49
3.2.1.4	Tailwater Pool Bottom Distance from Culvert Invert	51
3.2.1.5	Fish Density	54
3.2.2	Baseline Characterization	55
3.2.2.1	Relationship between Passage Success and Culvert Discharge	55
3.2.2.2	Horizontal Distribution of Fish Successfully Passing through the Culvert	57
3.2.2.3	Relationship between Passage Success and Hydraulics	58
<b>4.0</b>	<b>DISCUSSION</b>	<b>61</b>
<b>5.0</b>	<b>CONCLUSIONS AND RECOMMENDATIONS</b>	<b>67</b>
<b>5.0</b>	<b>REFERENCES</b>	<b>71</b>
	<b>APPENDIX A: CULVERT TEST BED (CTB) FACILITY DESCRIPTION</b>	<b>A.1</b>

## Figures

Figure 1. Culvert Test Bed.....	1
Figure 2. Example Culvert. (Note: this replacement culvert has not been re-watered.....	4
Figure 3. Plan and Elevation Schematics of the Culvert Test Bed.....	6
Figure 4. Culvert Test Bed Showing Tailwater Tank, A-frame, and Culvert Barrel.....	6
Figure 5. Schematic of the Water Supply System for the CTB and Fish Ponds.....	7
Figure 6. ADV Probes: (a) Down-looking and (b) Side-looking.....	10
Figure 7. Three-axis Gantry Used to Position the ADV.....	10
Figure 8. Gantry Extension Arm.....	11
Figure 9. Manometer Tubes.....	11
Figure 10. Perspective View of Culvert Showing the Locations of Velocity Measurements.....	12
Figure 11. Elevation View of Culvert Showing the Locations of Velocity Measurements and Reference Coordinate System.....	13
Figure 12. Plan View of Culvert Showing the Locations of Velocity Measurements and Reference Coordinate System.....	13
Figure 13. Cross Section of Culvert Showing the Reference Coordinate System.....	14
Figure 14. Cross section of Locations Measured with the ADV.....	15
Figure 15. Technical Approach to Establish Evaluation Protocols.....	19
Figure 16. Juvenile Coho Salmon (FL about 125 mm) Used in Tests at the CTB.....	20
Figure 17. Net Pen in the TW Tank.....	21
Figure 18. Video Equipment for Real-time Monitoring in 2003.....	22
Figure 19. Digital Video Equipment for Real-time Monitoring in 2004.....	22
Figure 20. Water Surface Profiles for 1, 2, 4, 8, and 16 cfs.....	26
Figure 21. Additional Water Surface Profiles for 1.5, 2.5, 3.5, and 4 cfs.....	26
Figure 22. Streamwise Velocity Data ( $V_x$ ).....	27
Figure 23. Turbulence Intensities (RMS).....	31
Figure 24. Vertical Velocity Profiles for Various Distances Down the Culvert.....	35
Figure 25. Contour Plots of Velocity (fps).....	39
Figure 26. Contour Plots of Turbulence Intensity (fps).....	40
Figure 27. Picture of the Flow Conditions at the Culvert Inlet.....	41
Figure 28. Longitudinal Profiles of Stream-wise Velocity ( $V_x$ ).....	41
Figure 29. Longitudinal Profiles of Stream-wise RMS (turbulence intensity).....	42
Figure 30. Longitudinal Profiles of Stream-wise Velocity ( $V_x$ ).....	42
Figure 31. Longitudinal Profiles of Stream-wise RMS (turbulence intensity).....	43
Figure 32. Edge Velocities versus Average Velocity (discharge/area).....	44

Figure 33. Edge RMS Values versus Average Velocity (discharge/area)..... 44

Figure 34. Maximum Velocity Measured at a Cross Section versus the Average Velocity (Q/A).  
..... 45

Figure 35. TW Tank Showing Pool Depths. .... 52

Figure 36. Relationship between Passage Success and Culvert Discharge ..... 57

Figure 37. Horizontal Distribution of Fish Entering the HW Tank..... 58

Figure 38. Scatterplot of Passage Success and Hydraulic Variables. (a) mean velocity over the  
entire cross section; (b) mean velocity in the RVZ; (c) maximum velocity over the entire  
cross section; and (d) mean turbulence intensity in the RVZ. .... 59

Figure 39. Example Time-Series of Stream-wise Velocity in the RVZ at 4 cfs in the Middle of  
the Culvert Test Bed, April and May 2003..... 59

## Tables

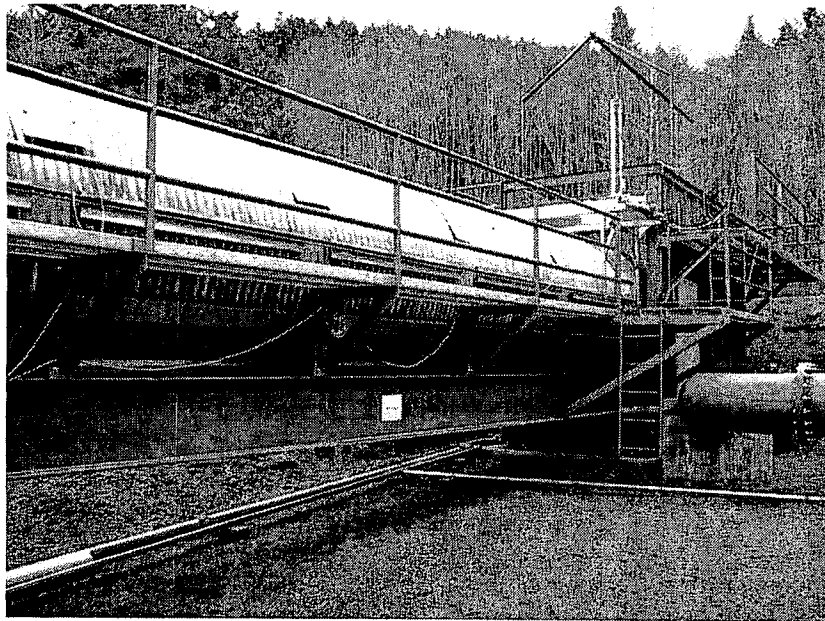
Table 1. Phases and Status of the Culvert Test Bed Research Program.....	2
Table 2. Chronology of Key Events in the CTB Research Program (as of December 2004). (Data from time periods with bolding and an asterisk* are reported herein.) .....	2
Table 3. Possible Experimental Factors for the Culvert Test Bed Evaluation. ....	7
Table 4. Sequence of Actions to Obtain Hydraulic Data Using the ADV. ....	16
Table 5. Summary Table of Hydraulic Measurements and Calculations. ....	25
Table 6. Test Conditions for Focused Experiments for Protocol Development for Validation of Basic Methods in April 8-16, 2003 at the CTB. ....	46
Table 7. Summary Results from Focused Experiments on Validation of Basic Methods during April 8-16, 2003. Test conditions are described in Table 6.....	47
Table 8. Test Conditions for Focused experiments for Protocol Development on Time of Day and Shading in April 22 to May 9, 2003 at the CTB. ....	48
Table 9. Summary Results from Focused Experiments for Protocol Development on Time of Day and Shading in April 22 to May 9, 2003 at the CTB. ....	49
Table 10. Test Conditions for Focused Experiments for Protocol Development on Backwatering in May 19-22, 2003 at the CTB. ....	50
Table 11. Summary Results from Focused Experiments for Protocol Development on Backwatering during May 19-22, 2003 at the CTB. All test were at night with 20 fish each, except for the last which had 300 fish. Test conditions are described in Table 10.....	50
Table 12. Test Conditions for Focused Experiments for Protocol Development on Pool Depth in November 8-13, 2004 at the CTB.....	52
Table 13. Mean, Minimum, and Maximum Fish Sizes (Fork Length, FL) during Pool Depth Tests in November 2004. ....	53
Table 14. Summary Results from Focused Experiments for Protocol Development on Pool Depth in November 8-13, 2004 at the CTB.....	53
Table 15. Randomized Test Blocks for Fish Density Tests. ....	54
Table 16. Mean, Minimum, and Maximum Fish Sizes (Fork Length, FL) During Pool-Depth Tests in November 2004. ....	55
Table 17. Fish Passage Success Relative to Fish Density in November 2004 (low=1 fish/ft <sup>3</sup> ; middle=2 fish/ft <sup>3</sup> ; high=4 fish/ft <sup>3</sup> .).....	55
Table 18. Biological Baseline Characterization in May 27-30, 2003 at the CTB.....	56
Table 19. Results from Biological Baseline Characterization in May 27-30, 2003 at the CTB...	56
Table 20. Recommendations for Evaluation Protocols at the CTB.....	68





## 1.0 Introduction

The Battelle Pacific Northwest Division is working with the Washington State Department of Transportation (WSDOT) and its partner agencies<sup>1</sup> on a research program relevant to new and retrofit culverts. The goal of this research program is to identify culvert bed configurations, designs, and associated hydraulic conditions that allow successful movement of juvenile salmonids upstream, while passing water, sediment, and debris downstream. To this end, WSDOT in cooperation with the Washington Department of Fish and Wildlife (WDFW) established a culvert test bed (Figure 1) at the WDFW's Skookumchuck Hatchery in western Washington State.



**Figure 1.** Culvert Test Bed. This photograph shows the culvert (foreground) and headwater tank (right side).

The overall objectives of the culvert test bed (CTB) research program are to: 1) create a conceptual design; 2) select a site; 3) design, fabricate, install, and test the CTB; 4) develop evaluation protocols for hydraulic and biological measurements; 5) conduct tests at the CTB under various experimental conditions; and 6) report results. Aligned with these objectives, the CTB research program has six phases (Table 1). Phases 1-3 are complete. Work on Phase 4 (Protocol Development) is the subject of this report. Phases 5 (Biological and Hydraulic Testing) and 6 (Reporting) are underway. The program phases build upon one another and provide specific milestones to manage the program.

---

<sup>1</sup> Partner agencies include the Alaska Department of Fish and Game, Alaska Department of Transportation, the California Department of Transportation, the Federal Highway Administration, and the Oregon Department of Transportation.

**Table 1.** Phases and Status of the Culvert Test Bed Research Program.

Phase	Description	Status
Phase 1. Conceptual Design	A conceptual model for behavior of juvenile salmonids passing upstream through culverts was developed and used in design of the CTB (Pearson et al. 2002). The final design input sheet and program development plan were submitted to WSDOT.	Complete
Phase 2. Site Selection	The site selected for the CTB was the WDFW Skookumchuck Hatchery on the Skookumchuck River in western Washington State.	Complete
Phase 3. Design, Fabrication, and Installation	Under a competitive bid process, Baseline Construction, Inc. of Portland, Oregon, was selected to fabricate and install the CTB. Montgomery Watson Harza provided detailed engineering design.	Complete
Phase 4. Protocols	These are procedures will be used consistently in the hydraulic and biological tests in Phase 5. Protocols ensure data comparability.	Complete (reported herein)
Phase 5. Biological and Hydraulic Tests	This phase includes the baseline culvert characterization and other tests using the CTB, such as the Leaping Ability study in December 2004.	Underway
Phase 6. Reporting	Reporting is the phase where the results of the CTB program are documented. This phase also includes scientific presentations.	Underway

WSDOT initiated the program in 2001 (Table 2). The CTB was installed and ready for research purposes in March 2003. We conducted research in three main periods: April/May 2003, November 2004, and December 2004. Steering Committee meetings were held in March 2003 and February 2004 to provide guidance to the program.

**Table 2.** Chronology of Key Events in the CTB Research Program (as of December 2004).  
(Data from time periods with bolding and an asterisk\* are reported herein.)

Time Period	Event
Jan 2001	CTB Program initiated
Jul 2002	Phase 1 Conceptual Design completed
Jul-Aug 2002	Competitive bid process to fabricate and install the CTB.
Aug 2002	Baseline Construction, Inc. of Portland, OR selected to build the CTB.
Aug 2002	Permits to use the Skookumchuck Hatchery near Tenino, WA secured.
Aug 2002	Phase 2 Site Selection completed
Aug 2002 – Mar 2003	Fabrication and installation
Aug 2002	Scientific presentation at the annual meeting of the American Fisheries Society
Mar 2003	Phase 3 Design, Fabrication and Installation of the CTB completed
Mar 2003	Steering Committee meeting in Seattle, WA
<b>*Apr-May 2003</b>	<b>Phase 4 Protocol Development initiated – biological tests for time of day, shading, backwatering, and white light</b>
<b>*Apr-May 2003</b>	<b>Phase 5 Testing, baseline characterization initiated – hydraulic measurements for 1, 2, 3, 4, 8, 12, and 16 cubic feet per second (cfs)</b>
<b>*May 2003</b>	<b>Phase 5 Testing, baseline characterization – passage success vs. discharge</b>

<b>Time Period</b>	<b>Event</b>
Jul 2003	Phase 6 Reporting, draft progress report on protocol development and baseline tests submitted to WSDOT
Feb 2004	Steering Committee meeting in Olympia, Washington
*Nov 2004	<b>Phase 4 Protocol Development continued: pool depth and fish density tests</b>
*Nov 2004	<b>Phase 5 Testing, baseline characterization continued – hydraulic measurements for 1.5, 2.5, and 3.5 cfs</b>
Dec 2004	Leaping ability study

## 1.1 Report Objectives

This report provides data from the hydraulic and biological tests conducted at the CTB in April/May 2003 and November 2004. Results from the leaping ability tests in December 2004 will be reported separately. The objectives for the research reported herein were as follows:

1. Develop evaluation protocols by assessing:
  - a. Hydraulics: equipment, sampling locations, and data analysis
  - b. Biological: test fish, fish handling and retrieval, video monitoring, passage success metrics, data analysis, and the following test conditions:
    - i. Time of day and shading
    - ii. Backwatering
    - iii. Tailwater (TW) pool depth
    - iv. Fish density in TW pool
2. Test the evaluation protocols in hydraulic and biological characterizations of a "baseline culvert" (6 ft round, corrugated, 40 ft long, bare bed, and sloped 1.14%) as follows:
  - a. Obtain water velocity measurements for the following CTB discharges: 1.0, 1.5, 2.0, 2.5, 3.0, 3.5, 4.0, 8.0, and 16.0 cfs
  - b. Assess the relationship between fish passage success (PS) (defined in Section 2.2.1.4) and the following CTB discharges: 1.0, 1.5, 2.0, 2.5, 3.0, 3.5, 4.0 cfs
  - c. Determine the horizontal distribution of fish exiting the culvert into the headwater (HW) tank
  - d. Assess the relationship between fish passage success and hydraulic conditions.
3. Provide recommendations for evaluation protocols that will be used in future tests of culvert types and bed configurations.

## 1.2 Background and Need

The culvert test bed research program is designed to identify culvert designs and associated hydraulic conditions under which juvenile salmonids will be able to successfully swim upstream. Because several salmonid species in the Pacific Northwest are now listed under the Endangered Species Act, the impacts to these fish and their habitats have come under increasing scrutiny. Salmonids utilize freshwater areas during both juvenile and adult stages of their life cycles. Juveniles have different requirements for water quality, depth, velocity, and other parameters than adults, although both life stages use the same stream. Culverts that convey a stream's flow underneath roads or other obstacles must be designed for a wide range of water flows. During low water periods, there must be enough water depth in the culvert for adult and juvenile fish to swim in. During high water periods, culverts must be large enough to pass floodwaters and not become blocked by debris. An example culvert is shown in Figure 2.



**Figure 2.** Example Culvert. (Note: this replacement culvert has not been re-watered.)

Most culvert passage research to date has been conducted on the swimming abilities of adult salmonids migrating upstream to spawning sites. For example, mathematical models to aid culvert design for adult salmonids are fairly well established. The conditions optimal for culvert passage by juvenile salmonids, however, are not as well understood (Behlke et al. 1991). Although the primary movement usually attributed to juveniles is downstream toward the ocean, recent research has indicated that upstream movement by juveniles is more common than previously thought (Kahler and Quinn 1998; Kahler et al. 2001), as juvenile salmon move to find acceptable feeding areas and refugia. If a suitable habitat is on the upstream side of a culvert, it is important that the juveniles not be inhibited from swimming up through the culvert to occupy this area. There are tens of thousands of culverts in the State of Washington, many which impede fish passage. Therefore, determining the appropriate hydraulic and fish passage designs for new and retrofitted culverts before installation has substantial environmental implications for salmonids.

Experiments in the culvert test bed will include measuring the hydraulic conditions (mean velocity, turbulence, and water depth) associated with various culvert designs under various slopes and flow regimes. These measures will be related to repeatable, quantitative estimates of juvenile fish passage success. Water velocity distribution affects juvenile salmonid passage success because these fish have limited swimming capabilities. Thus, to travel upstream through a culvert, juvenile fish may use the low-velocity boundary layer region near the culvert walls

(Barber and Downs 1996; Powers et al. 1997). Juvenile salmonids also may use the low-velocity regions that form in the lee of culvert corrugations or baffles as rest areas (Powers et al. 1997). The turbulence conditions in the boundary layer of corrugated culverts may be particularly important to juvenile salmon (Kahler and Quinn 1998; Powers et al. 1997) because turbulent velocity bursts can exceed the swimming ability of the fish. Understanding the relationship between hydraulic conditions and juvenile passage upstream in culverts will contribute to the scientific basis for fish passage criteria.

There is currently a pressing need to make decisions concerning when to retrofit a culvert and when to replace it. Hydraulic design methods for culvert retrofits may be invoked when stream simulation methods are impractical or inapplicable. With the goal of maximizing successful fish passage at a reasonable cost, hydraulic design for corrective retrofits will entail identifying the hydraulic and physical features that result in successful passage. These physical features might include baffles or bed material for roughness and inlet or outlet structures to provide conditions suitable for passage. Decisions will need to be made on which culverts can be retrofitted and which must be replaced entirely. The results of the CTB research will aid this decision-making process.

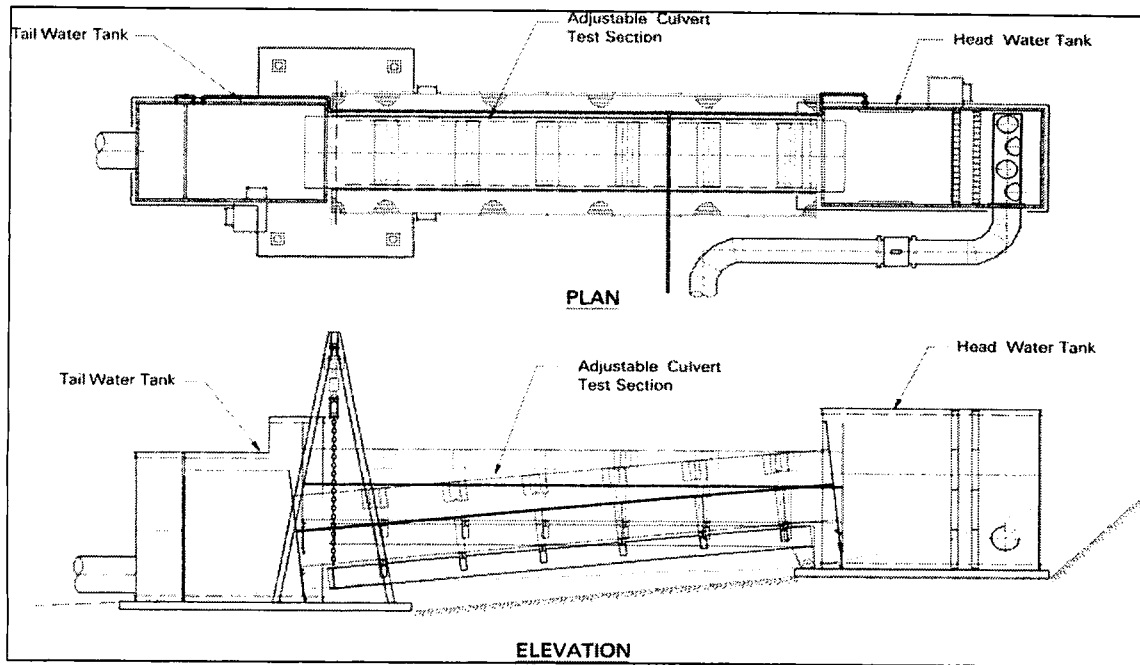
In summary, over the course of the CTB research program, the information and protocols developed in the report herein will be used to guide study design and provide procedures to evaluate the upstream passage success of juvenile salmonids in the CTB for various culvert types, discharges, slopes, and bed types. The end result will be data and information that design engineers can use to ensure retrofit culverts have a high probability of passing both juvenile and adult salmon.

### **1.3 CTB Site Description**

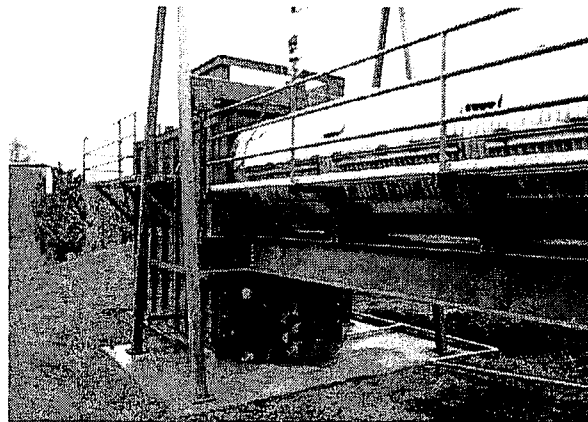
The CTB (Figure 3) is located at the WDFW's coho salmon and steelhead rearing facility on the Skookumchuck River near Tenino, Washington. Other species may be accommodated at the facility on an ad hoc basis. Water for the facility is drawn from the reservoir behind Skookumchuck Dam, located upstream about 0.5 miles. The CTB is integrated into the facility's water supply system. The CTB is designed to accommodate up to 25 cfs, although maximum water discharge through the fish rearing pond system is 20 cfs. The CTB is 40 ft long and can handle culverts up to 6 ft diameter. The CTB is described in detail in Appendix A.

The CTB (Figure 4) has a nominal 5-year design life. It has a concrete foundation, pipe supports, and fabricated steel components. Design criteria for the CTB included the following:

- 0 to 25 cfs hydraulic capacity
- slopes adjustable up to 10% using A-frame, hoist assembly
- interchangeable culverts with access
- adjustable tail water elevation
- fish friendly release and recapture
- minimal impacts to hatchery operations.

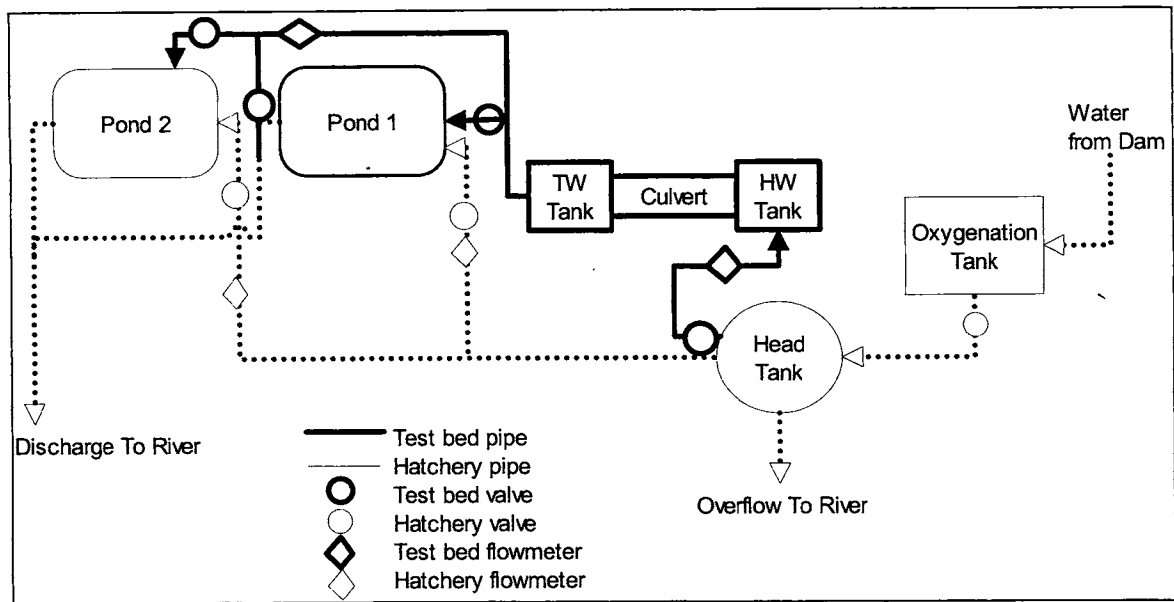


**Figure 3.** Plan and Elevation Schematics of the Culvert Test Bed. Engineering design by Montgomery-Watson-Harza Global, Inc.



**Figure 4.** Culvert Test Bed Showing Tailwater Tank, A-frame, and Culvert Barrel.

The hydraulic features of the CTB include the ability to use existing facility's water supply with a flow range of 0 to 20 cfs and discharge it into the facility water system; separate headers for each pond so that the CTB and facility flow can run simultaneously; the ability to run approximately 10 cfs to each existing rearing pond; overflow protection; and flow metering into CTB and to the rearing ponds (Figure 5).



**Figure 5.** Schematic of the Water Supply System for the CTB and Fish Ponds.

The primary experimental factors of the CTB are related to culvert structure (type and bed configuration) and flows (discharge and slope) (Table 3). In its 2003 meeting, the Steering Committee noted that wisely choosing the combinations of factors to test will be critical to the success of the research program.

**Table 3.** Possible Experimental Factors for the Culvert Test Bed Evaluation.

Factor	Levels				
Culvert Type <sup>(a)</sup>	Round 6-ft unflattened ends	Round 3-ft	Round 2-ft	Box 5x3 ft <sup>(b)</sup>	Pipe Arch <sup>(c)</sup> 81x59 inch
Shade	None	Upstream	Downstream	Both	----
Bed configuration	Bare corrugation	Rock and gravel <sup>(d)</sup>	Baffles (various)	----	----
Slope	Near level	Maximum 10 deg	----	----	----
Culvert Discharge	1 cfs	Maximum 20 cfs	----	----	----
Period	Daytime	Dusk	Night	----	----
TW Pool Depth	Shallow (9 in)	Middle (15 in)	Deep (21 in)	----	----
Initial Fish Density in the TW Tank	Low (1 fish/ft <sup>3</sup> )	Middle (2 fish/ft <sup>3</sup> )	High (4 fish/ft <sup>3</sup> )	----	----

- (a) All test culverts presently have spiraled corrugations.
- (b) Box is not concrete but mocked up from lighter materials and the sides may be plastered with concrete.
- (c) Round and pipe arch are corrugated steel.
- (d) Washed coarse sand and pea gravel will be used to fill the interstitial spaces if required in some gravel bed configurations. A mock up for some gravel bed configurations will be used to reduce the height in round culverts.



## **1.4 Report Contents**

Hydraulic and biological information is interlaced in each of the report's six main sections: Introduction, Methods, Results, Discussion, Conclusions and Recommendations, and References. The main body of the report closes with recommended evaluation protocols. Appendix A contains a detailed description of the CTB.

## 2.0 Methods

Methods are explained below for the hydraulic measurements and the biological tests.

### 2.1 Hydraulic Measurements

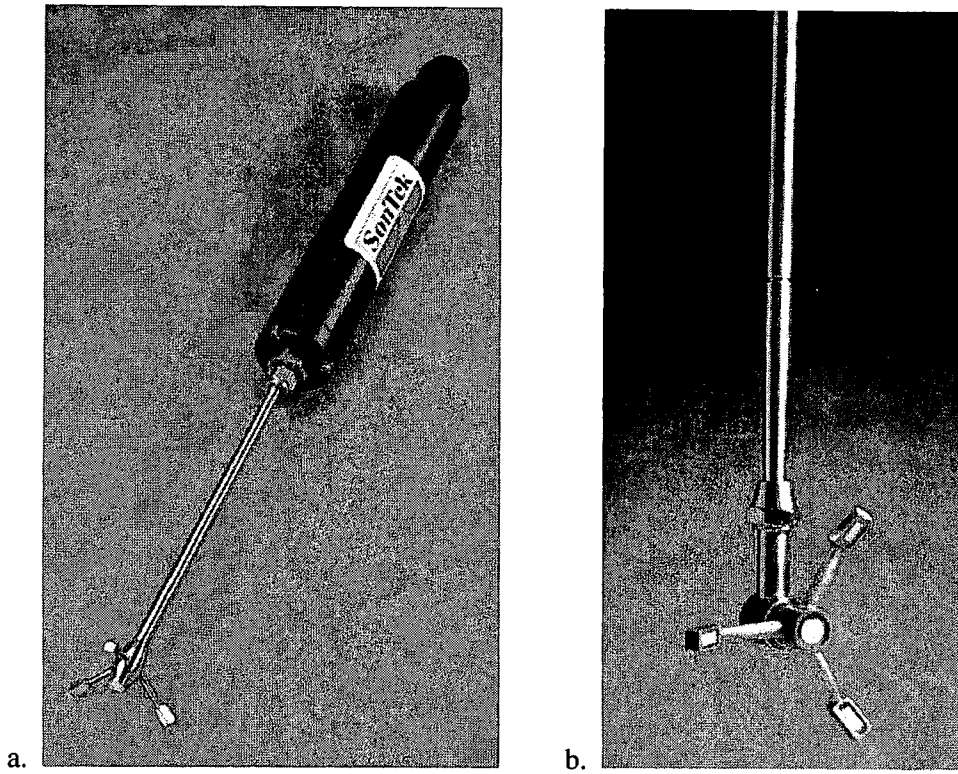
The protocols for hydraulic measurements covered 1) equipment, 2) sampling locations, and 3) data analysis. Note that sampling locations for hydraulic measurements in later studies may change depending on the presence of baffles or bed material in the culvert.

#### 2.1.1 Equipment

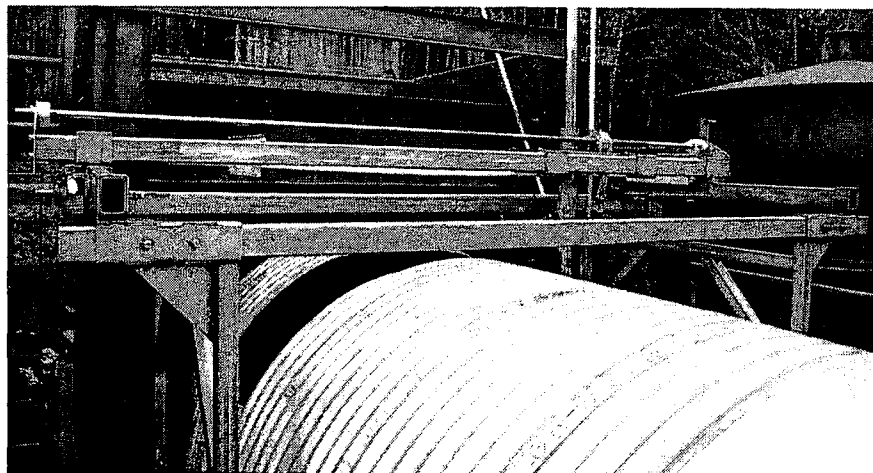
The velocity measurements should be taken with a SonTek (or similar instrument) 16-mHz micro-acoustic Doppler velocimeter (ADV, Figure 6) capable of measuring three-dimensional velocities at a sampling rate of up to 50 Hz (50 measurements per second). The ADV was selected for its capability to measure turbulent velocity fluctuations. Standard pitot tubes or propeller meters were not selected because those instruments do not provide turbulence measurements. A disadvantage of the ADV is the difficulty in obtaining measurements very near boundaries (within ~1 cm), but this was outweighed by the need for turbulence data. A high sampling rate is necessary to measure turbulence characteristics. The micro-ADV has a 5-cm focal length to allow for non-obtrusive velocity sampling. The instrument is positioned with a three-dimensional (xyz) manual traverse or gantry (Figure 7). Samples are collected at 50 Hz for 80 seconds (4000 data points) at each location (distances downstream from HW tank: 2.8, 9.4, 16.4, 23.5, 30.3, and 36.8 ft). The gantry slides on a sub-frame that moves on a track spanning the full length of the culvert apparatus. To sample closer to the left and right edges of the water column in shallow flow, the down-looking ADV (Figure 6a) should be replaced with a side-looking model (Figure 6b). Additionally, a guard tip was added to the ADV probe head to ensure that the acoustic receiver arms were not bent on the culvert walls. Measurements are taken through 1-ft wide access hatches spanning nearly the full width of the top half of the culvert. An extension arm is used to measure the entrance and exit conditions (Figure 8). In future sampling, the hatches may need to be modified to correspond to possible new sampling locations.

The water surface levels are read at 15 locations from manometer tubes tapped into the culvert. The water surface elevation in the culvert was determined by measuring the water height in the manometer tubes (Figure 9). Additional, water surface elevation measurements were obtained using a point gage that was positioned using the gantry.

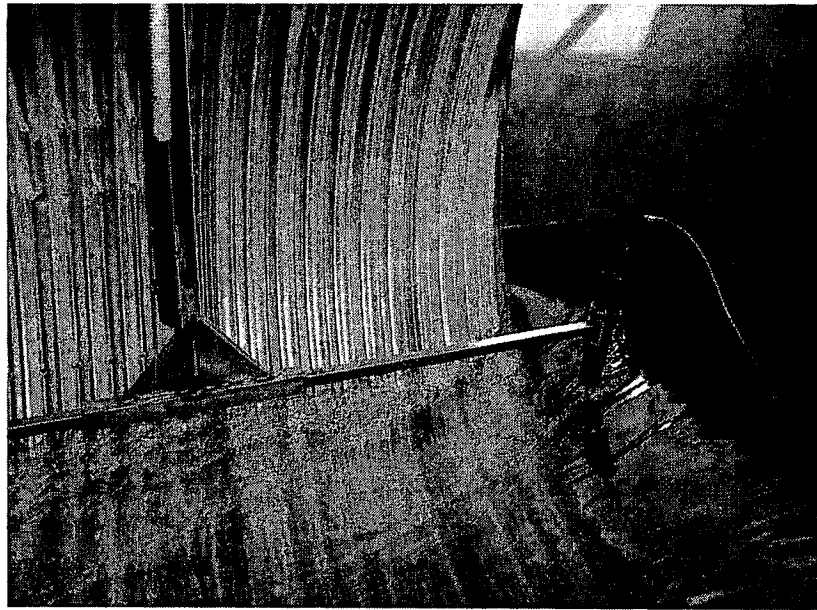
The discharge in the culvert was measured with an Ultramag™ magnetic flowmeter located upstream of the headwater tank (Figure 5).



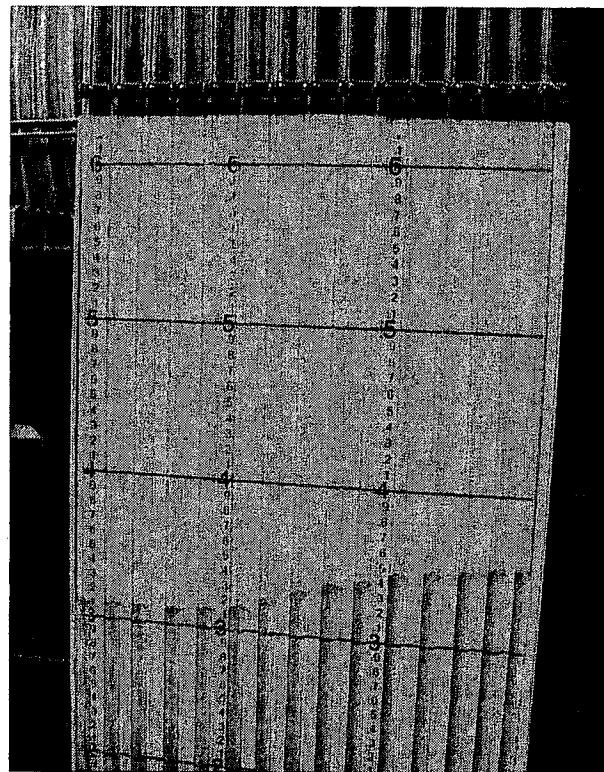
**Figure 6.** ADV Probes: (a) Down-looking and (b) Side-looking.



**Figure 7.** Three-axis Gantry Used to Position the ADV.



**Figure 8. Gantry Extension Arm.**

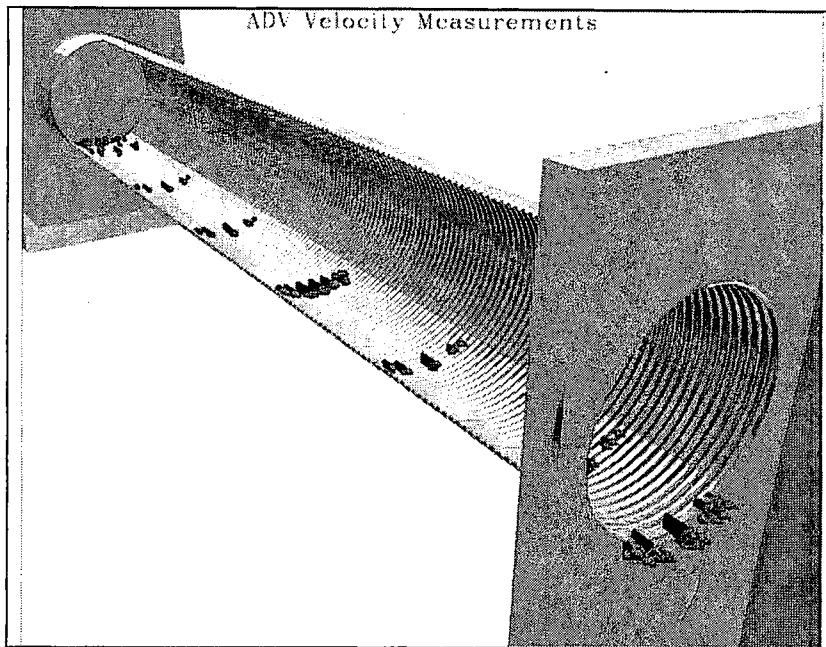


**Figure 9. Manometer Tubes.**

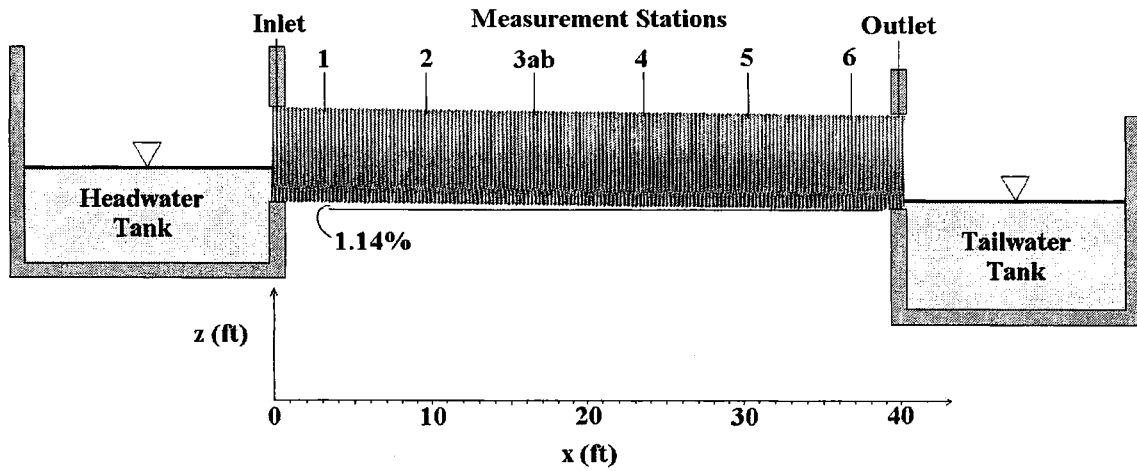
### 2.1.2 *Sampling Locations*

For a given discharge and slope, velocity data are collected at 11 cross sections in the CTB (Figures 10 through 13) as follows:

- 3" into HW tank
- coarse grid at culvert inlet
- coarse grids at hatches 1, 2, 3, 5, and 6
- two fine-grid cross sections 1.5" apart in station 4 (top and bottom of corrugation)
- coarse grid at culvert outlet
- 3" into TW tank.

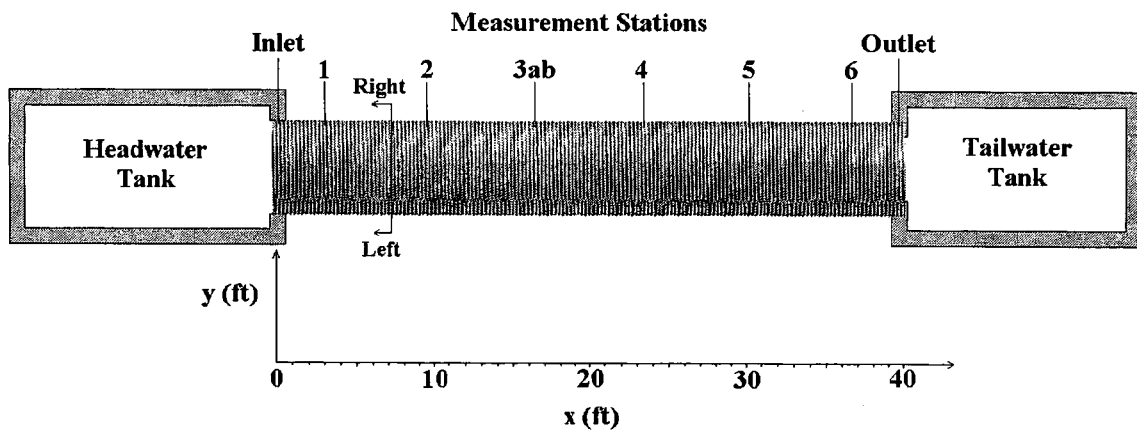


**Figure 10.** Perspective View of Culvert Showing the Locations of Velocity Measurements.



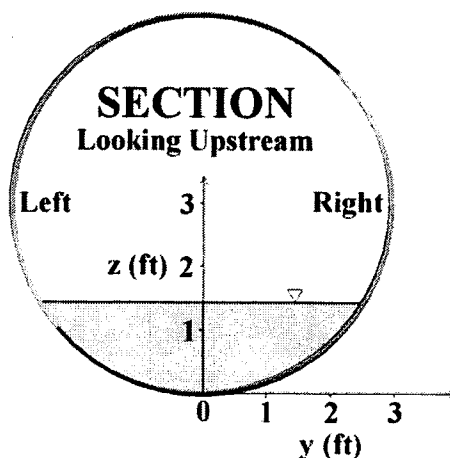
### ELEVATION

Figure 11. Elevation View of Culvert Showing the Locations of Velocity Measurements and Reference Coordinate System.



### PLAN

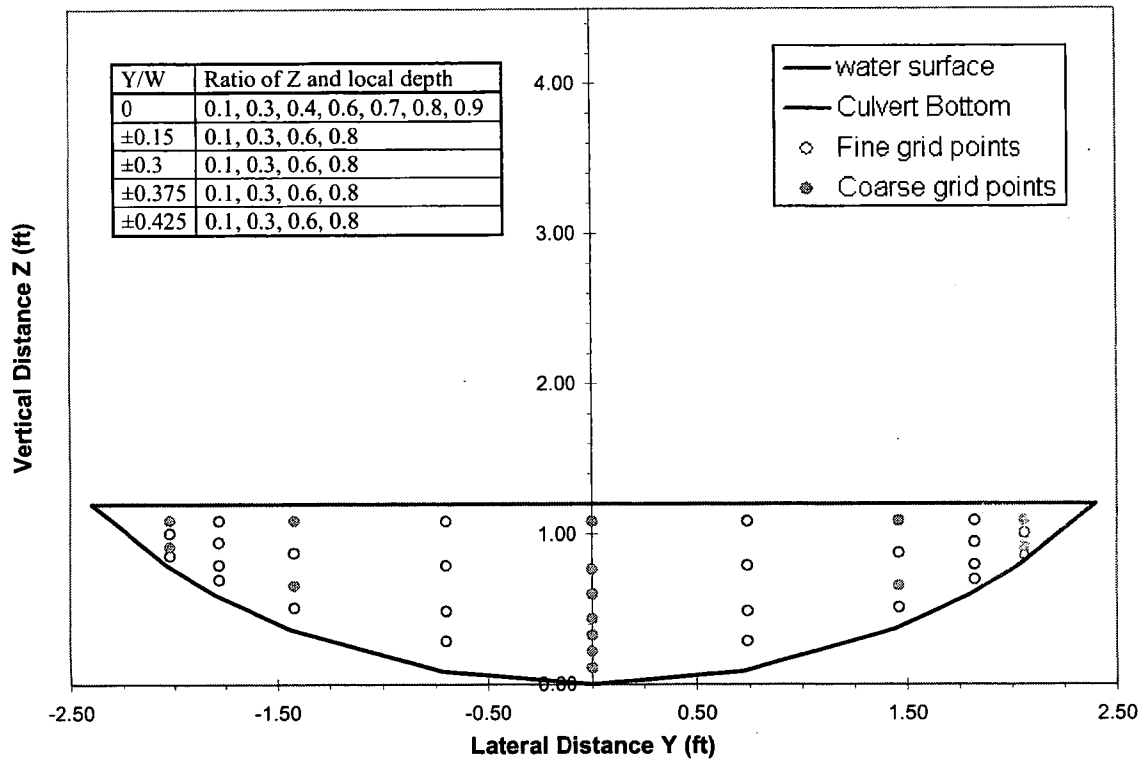
Figure 12. Plan View of Culvert Showing the Locations of Velocity Measurements and Reference Coordinate System.



**Figure 13.** Cross Section of Culvert Showing the Reference Coordinate System. The longitudinal location of the cross-section is shown in Figure 12.

The cross sections just inside the HW and TW tanks consist of five vertical profiles that extend from near the surface to below the lip of the culvert. The coarse grid consists of seven points in the centerline vertical profile and four points on each side (red points in Figure 14). The side regions measured were intended to correspond to what has been referred to as the “occupied zone” (Powers et al. 1997; Barber and Downs 1996). To establish a term that is independent of assumptions about fish location, the corner region on the right as seen looking upstream in the CTB will be referred to as the reduced velocity zone (RVZ). Data for the RVZ are from the measurements locations closest to the right side of the culvert barrel. The reason for only including the corner region on the right is explained in the results. The fine grid consists of nine vertical profiles for a total of up to 39 points (all points in Figure 14). The basic procedure used to take the ADV measurements is described in Table 4.

The hydraulics protocol is used for both centerline profiles and full grids. Full grids are collected at station 3 or station 4, depending upon the extent of backwater. They are collected in pairs separated by 1.5” to capture data from the troughs and ridges of the culvert corrugations. Centerline profiles and four 2-point profiles are collected at all other hatches. The extension arm is used at each end of the culvert to measure the velocities at the inlet and outlet and just inside the HW and TW tanks.



**Figure 14.** Cross Section of Locations Measured with the ADV. Red filled dots are coarse grid points measured at all stations. The fine grid measured at station 4 consists of all points shown. The reduced velocity zone (RVZ) at right culvert edge is shaded green. Lateral distance Y is from the center of the culvert barrel. Suppose the width of water surface is W, then beginning from the left side, the vertical profiles shown in the plot are  $Y/W = -0.425, -0.375, -0.3, -0.15, 0, 0.15, 0.3, 0.375, 0.425$ , respectively. The relative vertical distance (based on the local water depth) is listed in the embedded table.



**Table 4.** Sequence of Actions to Obtain Hydraulic Data Using the ADV.

Step	Action
1	Flush manometer and record zero water levels
2	Set discharge
3	Allow flow to stabilize for 30 minutes prior to proceeding to Step 4
4	Record manometer levels
5	Record HW and TW tank depths
6	Remove station and position gantry
7	Lower probe to surface
8	Move probe to left edge of water and record Y <sub>lew</sub> (field book and laptop)
9	Move probe to right edge of water and record Y <sub>rew</sub>
10	Record X of gantry leg (X <sub>gantry</sub> )
11	Record X on gantry carriage (X <sub>carriage</sub> )
12	Compute X <sub>probe</sub> = X <sub>leg</sub> +X <sub>carriage</sub> +9-X <sub>offset</sub>
13	Position probe at Y <sub>center</sub>
14	Lower probe to just touch surface and record surface Z (Z <sub>surf</sub> )
15	Lower probe until guard rests on the bottom and read Z (Z <sub>bott</sub> )
16	Calculate depth (d = Z <sub>surf</sub> - Z <sub>bott</sub> )
17	Enter Z <sub>surface</sub> , depth, Y <sub>lew</sub> , Y <sub>rew</sub> into spreadsheet
18	Enter appropriate probe offset parameters (submergence, focal distance, offset)
19	Take measurements at each point for 80 sec each on left side
20	Rotate probe to face right
21	Take measurements on right side
22	Raise probe out of culvert and move gantry to next hatch
23	Repeat from step 6

### 2.1.3 Data Analysis

The hydraulic data are analyzed to identify the average characteristics of the flow, the patterns of velocity and turbulence in the channel, the characteristics of the RVZ, inlet energy losses, and the evolution of the flow with downstream distance. The average velocity ( $V_{ave}$ ) is calculated by dividing discharge (Q) as measured with the flowmeter by wetted area (A) calculated from the depth ( $V_{ave} = Q/A$ ). The cross-sectional distributions of velocity and turbulence intensity are examined using point and contour plots.

Vertical profiles at each station are overlaid to show the evolution of the flow profile with downstream distance (Ead et al. 2000). These can be compared with most other studies of culvert hydraulics and used to demonstrate the degree of flow establishment at each measurement cross-section location. The water surface profile is also used to identify flow evolution and to estimate inlet loss coefficients.

Longitudinal profiles of average root-mean-square (RMS) velocity and streamwise velocity ( $V_x$ ) in both the entire cross section and the RVZ are plotted to examine the change in these parameters with distance down the culvert. The relative levels of turbulence and velocity in the RVZ at the entrance and exit of the culvert are of particular interest. Lastly, maximum velocity in the cross section ( $V_{max}$ ), and turbulence intensity and average velocity at the culvert edges are plotted against the average velocity in the cross section. Linear regressions are then performed to relate these parameters to the average velocity.

The turbulence intensity or RMS of the velocity at each measurement point is calculated from a time series of  $N$  velocity measurements. The following equation provides an example of the RMS calculation for the downstream velocity component:

$$RMS_u = \sqrt{\frac{1}{N} \sum_{x=1}^N (v_x - v_{avg})^2}$$

The average velocity and turbulence intensity in the RVZ is estimated for the culvert entrance, barrel, and exit using the outermost points measured in the shaded zone shown in Figure 14. The maximum velocity ( $V_{max}$ ) is estimated as the maximum 2-minute velocity measured at each cross section.

The Reynolds Number is a ratio of the inertial force to the viscous force. If the Reynolds Number is less than approximately 500, then the flow is considered to be laminar. When it is greater than approximately 500, then the flow is considered to be turbulent. For open-channel flow, the Reynolds Number may be calculated as follows:

$$Re = \frac{V_{avg} R_h}{\nu}$$

where,  $R_h$  is the hydraulic radius and is the ratio of the cross sectional area to the wetted perimeter, and  $\nu$  is the kinematic viscosity of water.

Similarly, the Froude Number is a ratio of the inertial force to the gravitational force and indicates whether flow is subcritical or supercritical. The Froude Number may be calculated as follows:

$$Fr = \frac{V_{avg}}{\sqrt{g \frac{A}{T}}}$$

where,  $A$  is the cross sectional area and  $T$  is the top width of the flow.

The Manning's Roughness Coefficient,  $n$ , can be calculated assuming uniform flow conditions as follows:

$$n = \frac{C_n}{V_{avg}} R_h^{\frac{2}{3}} S^{\frac{1}{2}}$$

where,  $c_n$  is a units coefficient (1.486 for English or 1.0 for metric), and  $S$  is the slope of the energy grade line. The Manning's  $n$  was calculated at all cross sections that were near uniformity and then averaged to determine a general culvert roughness for each discharge.

The entrance-loss coefficient,  $K_{ent}$ , indicates the amount of energy lost at the culvert entrance given by the following equation:

$$h_{le} = K_{ent} \frac{V^2}{2g}$$

where,  $h_{le}$  is the headloss at the culvert entrance. The headloss at the culvert entrance is calculated by extrapolating the energy gradeline within the culvert to the culvert entrance and subtracting the extrapolated energy from the actual energy at the culvert entrance. Then the entrance-loss coefficient may be determined by solving the equation above given the velocity in the culvert barrel.

As described later in the Discussion (Section 4), the combination of water velocity and turbulence together may determine the conditions creating a barrier to fish passage. An appropriate variable that combines water velocity and turbulence may be developed in future studies.

Empirical velocity reduction equations and predictive equations for the turbulence intensity in the RVZ are developed from power regressions. These relationships can be compared with those derived by other authors, such as those for velocity in the "occupied zone" by Ead et al. (2000), Barber and Downs (1996), and Powers et al. (1997). The relationship between average velocity and velocity in the RVZ also provide a reasonable means of estimating a reduced velocity to use in fish passage assessments. Power regressions are then performed to relate these parameters to the average velocity.

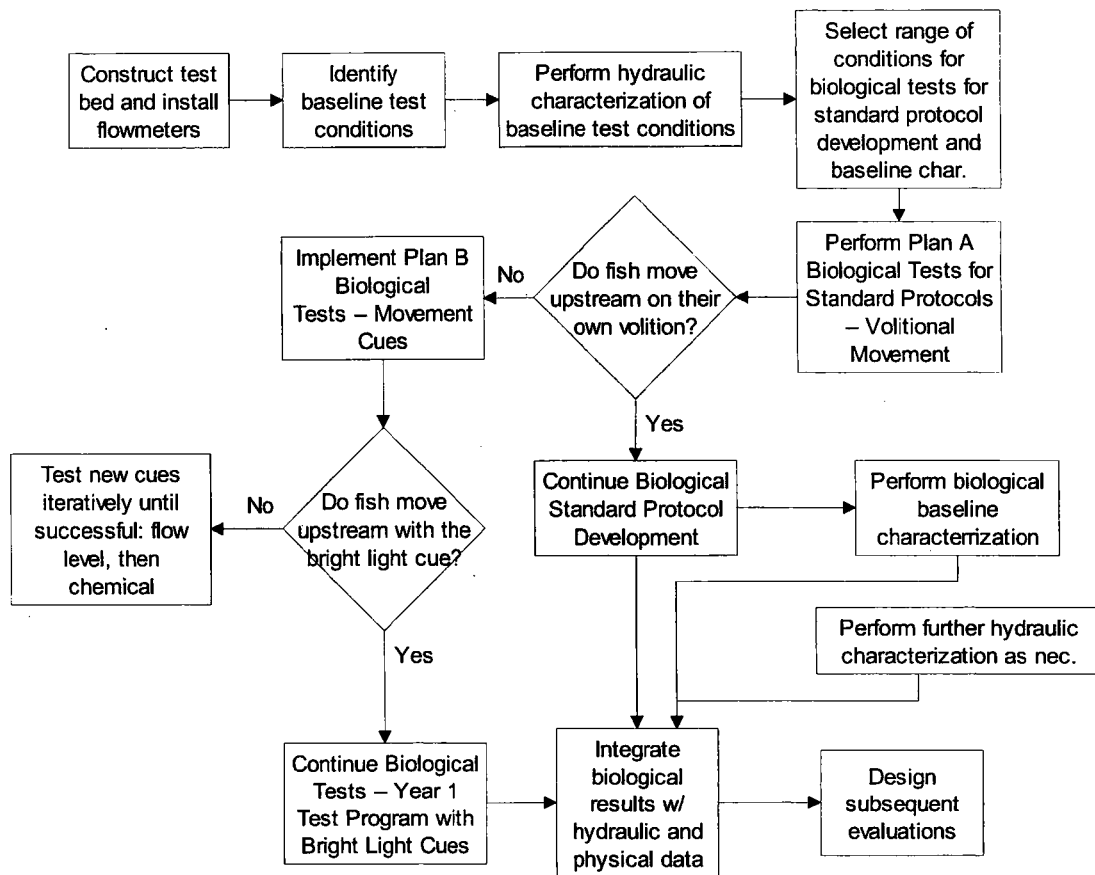
## 2.2 Biological Tests

Two key factors that influence upstream passage by juvenile salmonids are motivation and swimming capability/behavior. Environmental factors that affect upstream movement may include water temperature, substrate, water velocity, habitat degradation, turbidity, predation, overcrowding, light/shade, abrupt flow changes, prey odor, and feeding areas. Once motivated to move upstream, the capabilities and adaptive behaviors of the fish interact with the culvert's physical structure and hydraulic conditions to determine passage success. Biological tests were performed to determine the test conditions that enhance motivation to swim upstream so that experimental trials would focus on capability and adaptive behavior.

Developing CTB evaluation protocols involved technical investigations and focused experiments to determine appropriate conditions for biological tests. We used a sequential adaptive approach (Figure 15) to establish optimum test conditions, which were then assessed in baseline characterization tests. The issues resolved during development of the protocols in April/May 2003 and November 2004 included the following (the year the experiment was conducted is noted in parentheses):

- methods for fish handling and biological measurements, including the TW net pen (2003)
- time of day for testing (2003)
- shading and lighting (2003)
- backwatering (2003)
- tailwater pool depth (2004)
- fish density in the TW tank at test initiation (2004)

During the CTB research in 2003 and 2004, we followed “Plan A” in Figure 15, because a portion of the test fish showed volitional movement under the cues from such test conditions as night-time testing, low backwatering, and pool depth. Preliminary trials with bright lights did not appear promising and were not pursued. The level of volitional movement observed was sufficient to warrant further testing without going to “Plan B,” i.e., providing more cues or stimuli to promote upstream movement in the CTB. Therefore, we did not conduct trials with chemosensory cues such as egg odor or feeding attractants.



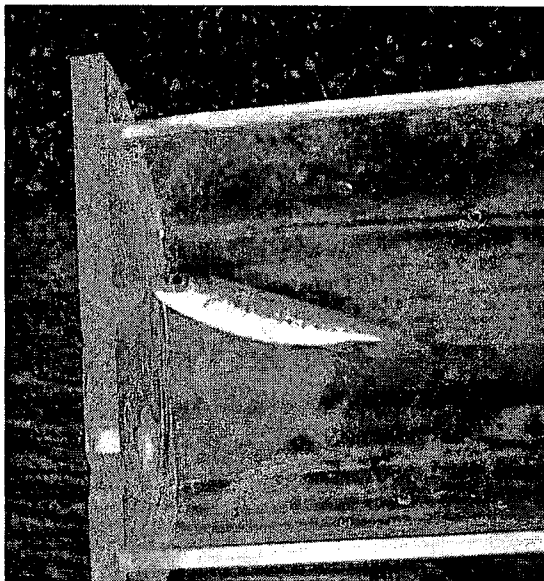
**Figure 15.** Technical Approach to Establish Evaluation Protocols.

This section contains methods to develop protocols for biological tests including 1) test fish, 2) fish handling and retrieval, 3) video monitoring, and 4) fish passage-success metric.

### **2.2.1 Test Fish**

Test fish were juvenile coho salmon (*Oncorhynchus kisutch*) from the WDFW Skookumchuck Hatchery. The fish raised at this facility are used in experiments using the same water source as that supplied to the rearing ponds. These fish are expected to experience less stress than fish acquired from other sources because there is no need to transport them long distances. In addition, the fish remain under the care of WDFW personnel until they are used in the CTB experiments. These juvenile coho salmon are assumed to represent juvenile salmonid species swimming capabilities and behaviors, although other fish may also be used with the appropriate permits and approvals.

We tested two size classes of juvenile coho salmon in April and May 2003. Relatively large juvenile coho salmon (104 mm to 177 mm fork length [FL]) (Figure 16) from the Bingham stock were available before they were released into the Skookumchuck River during the week of April 7, 2003. The hatchery released a smaller size class of juvenile coho salmon (40 mm to 62 mm FL) from the Wallace stock into Pond 1 on April 20, 2003. These fish were used in all remaining 2003 tests. In November 2004, the juvenile coho tested ranged from 61 mm to 126 mm, and averaged 93.4 mm.

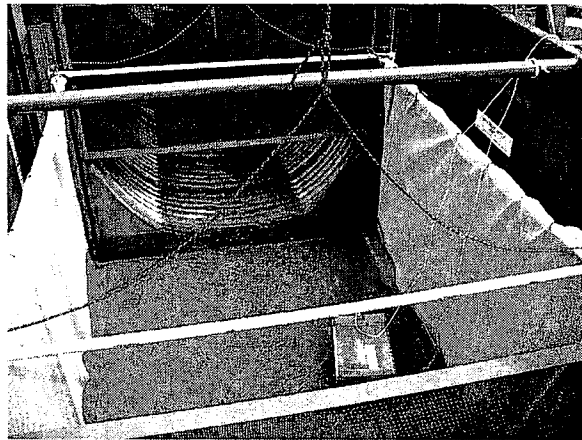


**Figure 16.** Juvenile Coho Salmon (FL about 125 mm) Used in Tests at the CTB.

### **2.2.2 Fish Handling and Retrieval**

For a given test, fish are handled in the sequence of events that starts when the test fish are obtained from a rearing pond and ends after the test when they are deposited in a holding raceway or a second rearing pond. Fish are not fed between the time of collection and testing to enhance

upstream movement. We observed that fish not fed for 24 h showed more active exploratory behavior in the 2-cfs tests than fish that were fed. Immediately before testing, the test fish are counted and carried from the holding tank to the CTB TW tank. With the CTB in operation at the prescribed flow and test conditions, the fish are released by emptying pails into the TW tank net pen (Figure 17) to start the test. In 2003 fish were held in a small holding cage in the TW tank prior to release into the TW tank. After release, these fish still exhibited exploratory behavior indicative of continued acclimation to the TW tank. Thus, we decided the holding cage was redundant and introduced unnecessary handling. Therefore, an acclimation period after release in the TW tank, without the holding cage, is incorporated into the total test duration and enables exploratory behavior to be part of the test.



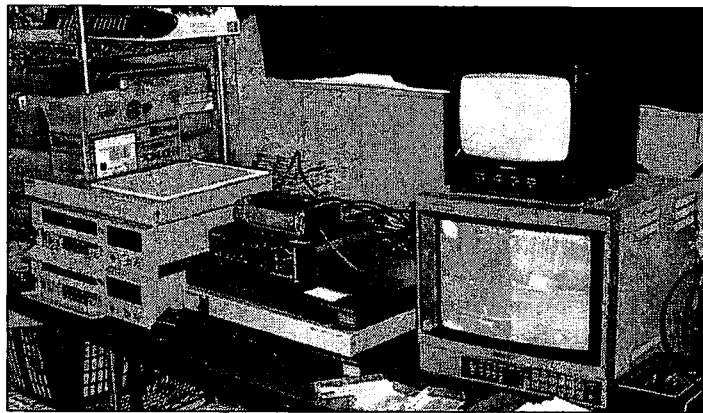
**Figure 17.** Net Pen in the TW Tank.

After a test is completed, flow is turned off and the end screens at the HW and TW tanks are lowered at the same time to isolate the fish in one of three areas: TW tank, culvert barrel, or HW tank. Fish are retrieved from each area and separately counted and measured. In the TW tank, a net pen (Figure 17) is used to confine the test fish and aid in the recapture of test fish. The net is constructed from 3/16-in. nylon-mesh netting with 1-in. diameter PVC frame. It can be raised and lowered to adjust the pool depth along with the false floor. Gaps around the sides are sealed with foam and neoprene material. At the end of each test, fish remaining in the net pen are dip netted as the flow subsides. To retrieve fish that remain in the culvert, personnel walk the length of the culvert and recover any fish using small dip nets. In the HW tank, a drain valve is opened allowing personnel to enter the tank and dip net the fish into a bucket. After retrieval, test fish are anesthetized, measured for fork length (FL), examined for general condition, and returned to a net pen located in the holding raceway or to a second rearing pond separate from the main hatchery population so that they are not used again in tests. The primary biological data are the counts of test fish in the three areas at the end of each test: the TW tank, the culvert, and the HW tank.

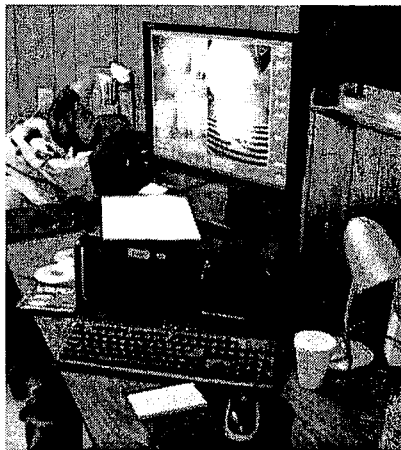
### **2.2.3 Video Monitoring**

A combination of high-resolution, low-light capable underwater and above-water cameras with associated equipment (Figures 18 and 19) is used to monitor fish movement and behavior throughout the tests. All cameras are monochrome CCD type 1/2- and 1/3-in. image sensor

capable of low-light operation and high resolution. A minimum of two underwater cameras are needed, one at the culvert inlet (HW tank) and one at the outlet (TW tank). The camera at the outlet is positioned to view fish entering the culvert from both sides. The camera in the headtank is located just beyond the culvert barrel. In addition, optional overhead cameras may be positioned inside the culvert at the downstream, middle, and upstream sections of the barrel. To enable viewing during the night periods, above-water and underwater infra-red illuminators (880 nm) are used in conjunction with each camera. This wavelength is beyond the spectral visual range of juvenile salmonids (Bowmaker and Kunz 1987; Lythgoe 1988). In 2003, the cameras were connected to a video multiplexer that allowed images from all the cameras to be displayed on one monitor and to be recorded in that format to a single analog 8-mm tape. During post processing, the video tape was played back through the multiplexer, which allowed individual or multiple camera scenes to be viewed on the same monitor. The video monitors, multiplexers, and recorders (Figures 18 and 19) are housed in a nearby work trailer. In 2004, new video equipment was purchased for the CTB research program. Now, cameras are connected to a digital video recording system that stores digital footage for later review (Figure 19). All video data is stored on DVDs for archiving.



**Figure 18.** Video Equipment for Real-time Monitoring in 2003.



**Figure 19.** Digital Video Equipment for Real-time Monitoring in 2004.

Video monitoring with the underwater camera in the TW tank is especially important because it provides insight into fish behavior near the culvert entrance. For example, some fish do not approach or attempt to enter the culvert. Therefore, based on observations during preliminary testing, we developed the following categories of fish behavior:

- feeding and milling;
- milling (no feeding);
- holding;
- schooling;
- territorial / aggressive;
- no fish observed for several minutes;
- enters culvert but falls back to TW tank within 3 seconds;
- enters culvert and remains there greater than 3 seconds;
- falls back after being in culvert more than 3 seconds;
- exits to HW tank.

During each 10-minute segment of a test, a box on a data sheet is checked once for each fish behavior observed. Two observers watched the video in real-time. Although it was not physically possible for the observers to note all significant events in real-time, these observations comprise a qualitative data set that is useful in interpreting the quantitative passage success data. Additional comments are added as specific behaviors or behavioral changes are observed. The observational records make it easy to find events of interest for further scrutiny.

#### **2.2.4 Fish Passage Success Metric**

As described in Section 2.2.2, test fish are counted before and after each test to determine fish passage success. For each fish test, a known number of fish are put into the TW tank. Following the test, the fish in the TW tank, HW tank, and culvert barrel are recaptured separately and counted. Care must be taken to ensure that all fish released are retrieved. Passage success (PS), in percent, is defined as follows:

$$PS = \frac{\text{Number of Fish in HW Tank at End of Test}}{\text{Total Number of Fish Released in TW Tank at Beginning of Test}} * 100$$





### 3.0 Results

This section contains 1) hydraulic results, 2) biological results, and 3) relationships between fish passage success and hydraulics. Because the technical approach started with volitional movement (Plan A, Figure 15), the baseline culvert had benign features (low flow, low slope). The tests for protocol development were conducted with the following general conditions:

- 6-ft round culvert, 40-ft long, spiral corrugations (3 in. x 1 in.), unflattened ends;
- bare bed condition;
- near-level slope (1.14%);
- low flow rates (1 to 4 cfs).

#### 3.1 Hydraulic Measurements

Hydraulic data collection entailed measuring water velocities at various sample locations in the culvert barrel during discharges of 1, 1.5, 2, 2.5, 3.5, 4, 8, and 16 cfs. A summary of the hydraulic measurements and calculations at each flow rate measured is presented in Table 5.

**Table 5.** Summary Table of Hydraulic Measurements and Calculations.

Q (cfs)	Depth (ft)	V <sub>avg</sub> (ft/s)	V <sub>max</sub> (ft/s)	V <sub>rvz</sub> (ft/s)	RMS <sub>avg</sub> (ft/s)	RMS <sub>max</sub> (ft/s)	RMS <sub>rvz</sub> (ft/s)	Fr (-)	Re (x10 <sup>4</sup> )	K <sub>ent</sub> (-)	n (-)
1	0.30	1.95	2.95	0.83	0.43	0.65	0.38	0.78	2.65	0.42	0.021
1.5	0.40	2.21	3.09	0.78	0.45	0.68	0.43	0.75	3.93	0.35	0.020
2	0.44	2.29	3.29	0.80	0.46	0.72	0.44	0.77	4.41	0.34	0.021
2.5	0.48	2.91	3.87	0.91	0.50	0.75	0.42	0.90	4.46	0.30	0.022
3.5	0.55	3.12	4.10	1.08	0.55	0.83	0.45	0.90	6.17	0.33	0.023
4	0.54	3.21	4.57	1.12	0.59	0.96	0.44	0.94	7.84	0.32	0.022
8	0.76	3.88	5.74	1.42	0.65	1.12	0.49	0.95	13.1	0.34	0.024
16	1.07	4.71	6.87	2.13	0.79	1.29	0.63	0.96	21.9	0.37	0.025

##### 3.1.1 Water-Surface Profiles

The water-surface profiles (Figures 20 and 21) show the inlet drop and backwater conditions for each flow rate. Backwatering (when the water surface in the TW tank extends upstream into the culvert barrel) was about 15 ft up the culvert at 1 and 2 cfs, but decreased to 10 ft at 4 cfs and was minimal at 8 cfs and above. Some backwatering was maintained at low flows to ensure the culvert outlet was not a fish barrier. The inlet drop is evident in all flows, with a standing wave forming about 4 ft into the culvert at 8 cfs and about 6 ft into the culvert at 16 cfs.

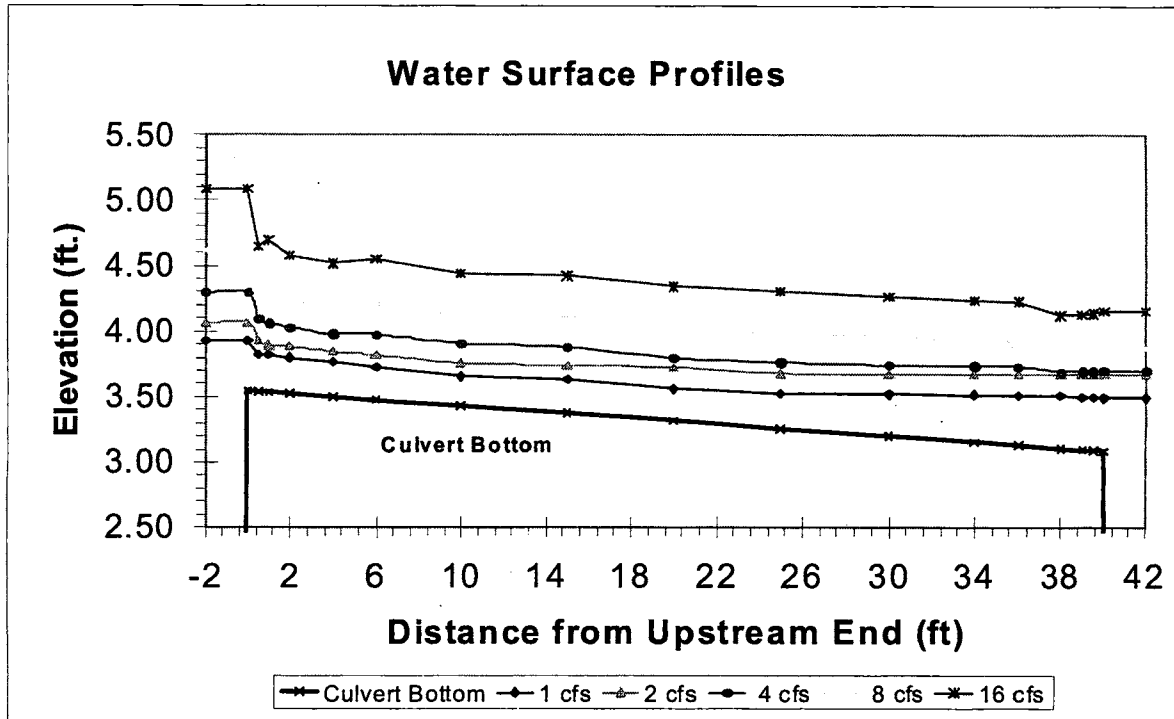


Figure 20. Water Surface Profiles for 1, 2, 4, 8, and 16 cfs.

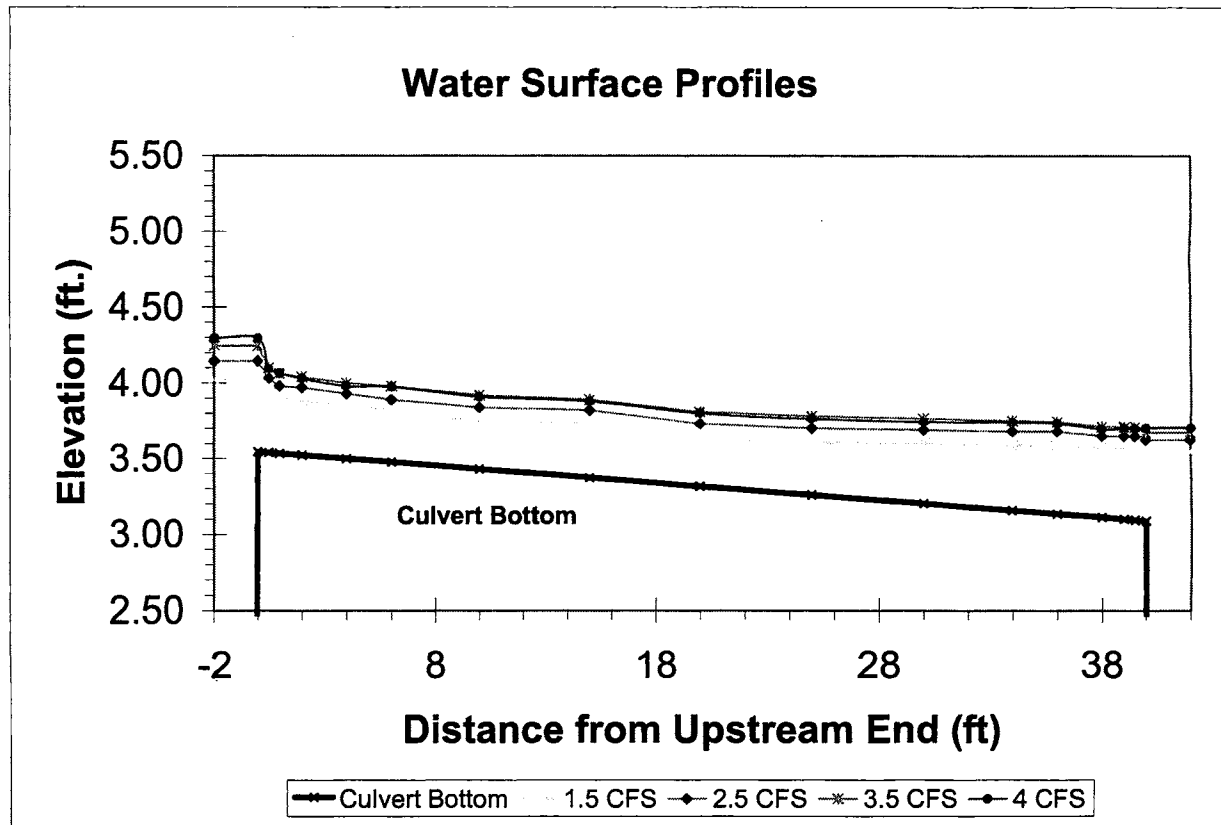


Figure 21. Additional Water Surface Profiles for 1.5, 2.5, 3.5, and 4 cfs.

3.1.2 Stream-wise Velocity and Turbulence Intensity

The fine-grid velocity data show that the stream-wise or axial velocity ( $V_x$ ), as seen looking upstream, was generally higher on the left side than on the right side of the culvert (Figure 22). This occurs because the flow is directed perpendicular to the culvert corrugations. The corrugations travel 21 in. upstream with each clockwise rotation (facing upstream) resulting in a right handed spiral with a pitch of approximately  $5.3^\circ$ . The velocity in the far right region of the flow is approximately 36% of the velocity in the center region. The lateral ( $V_y$ ) and vertical ( $V_z$ ) velocity components are nearly zero at all flows (Figure 22).

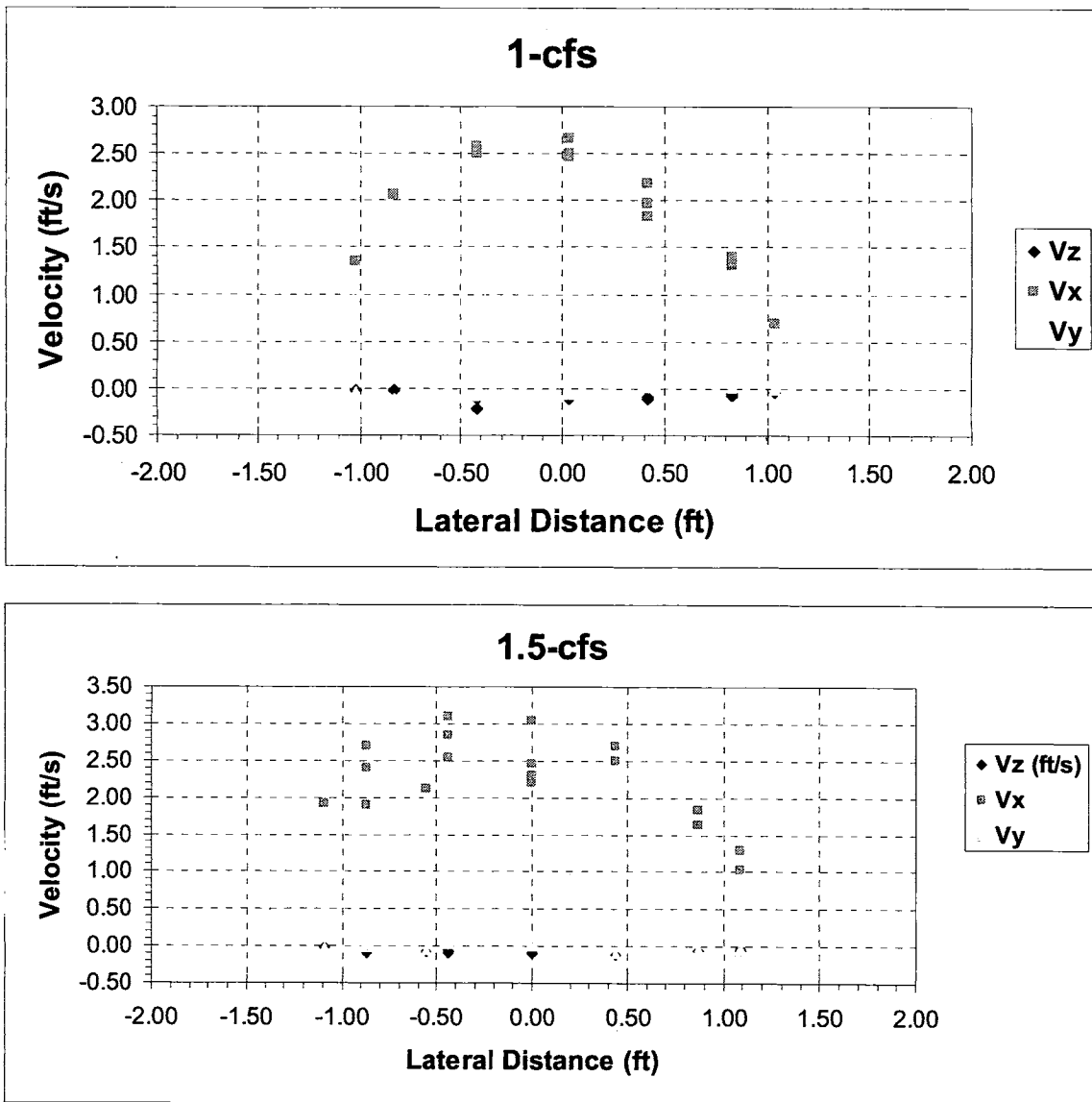


Figure 22. Streamwise velocity data ( $V_x$ ) at 1 (station 3) and 1.5 cfs (station 4). Station 3 (16.4 ft downstream) was used instead of station 4 (23.5 ft downstream) at 1 cfs to be upstream of the backwater effects; measurements for all discharges except 1 cfs were at station 4. Figure 22 is continued on the following three pages.

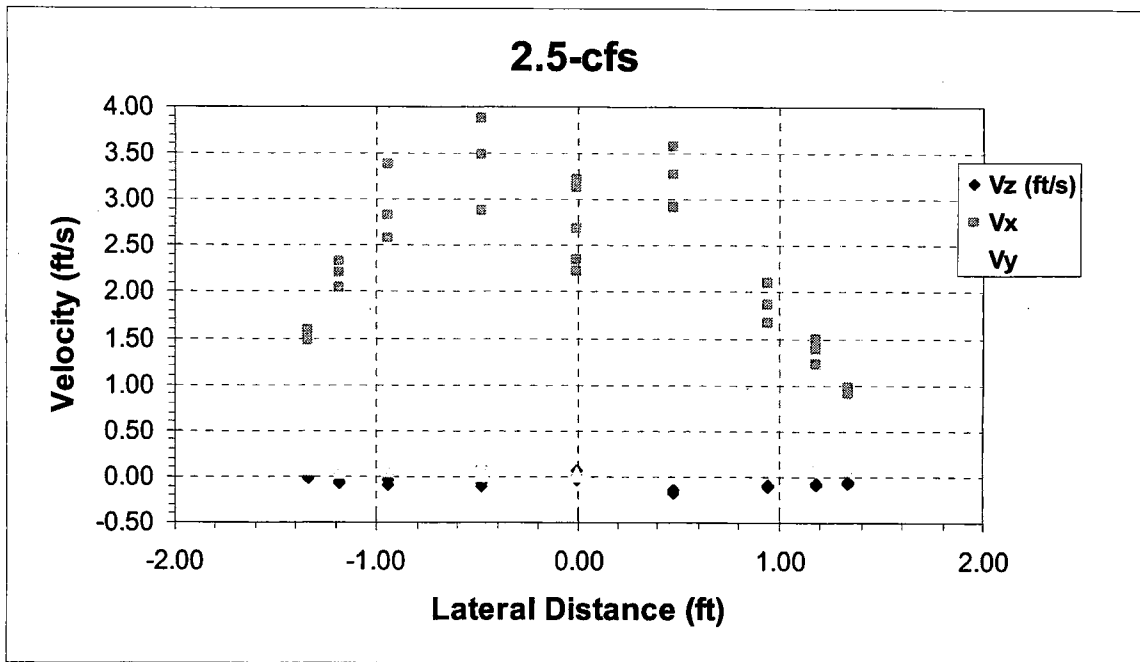
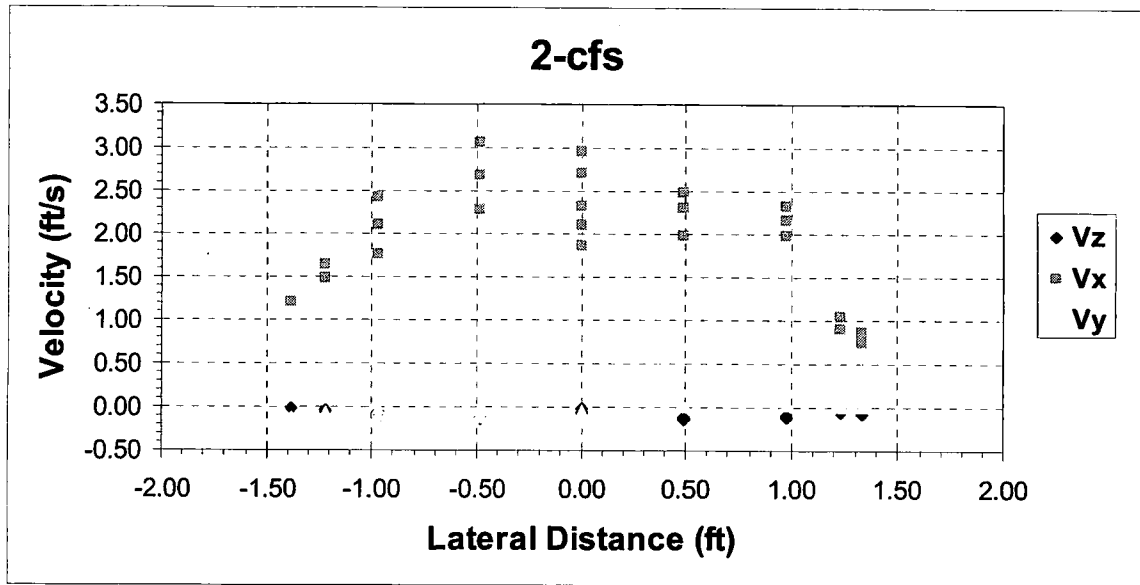


Figure 22 (cont'). Streamwise Velocity Data for 2 and 2.5 cfs (station 4).

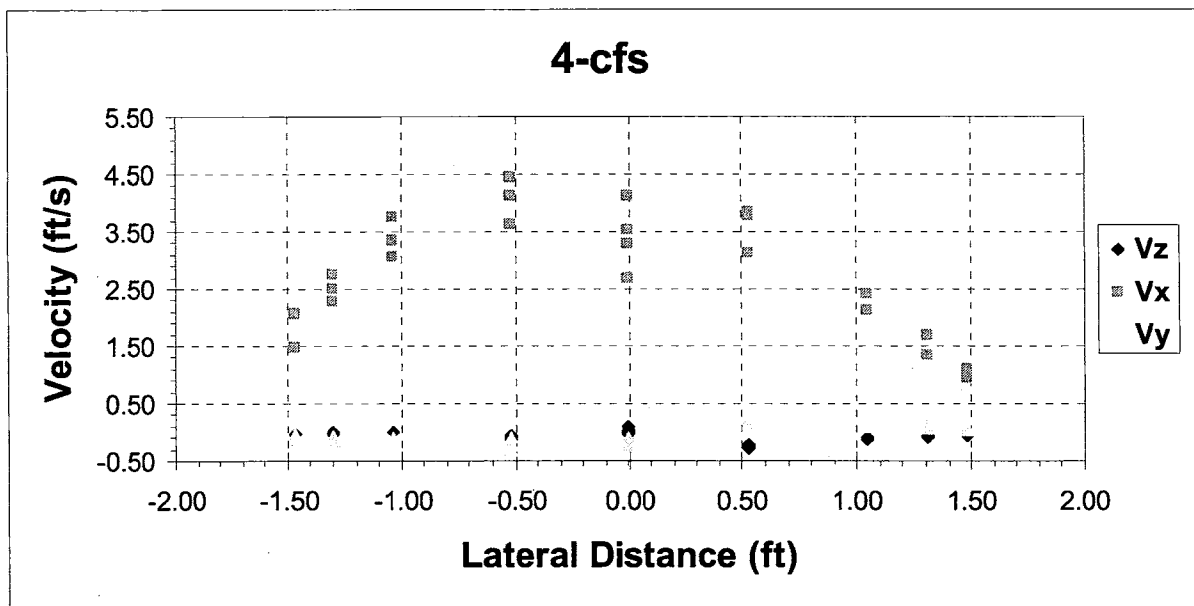
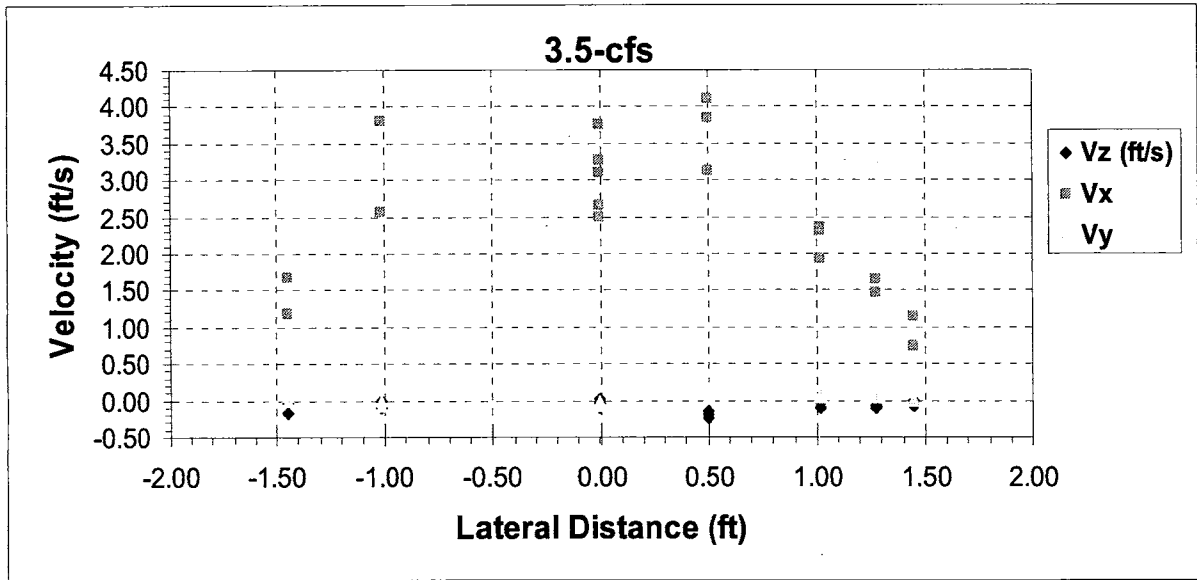


Figure 22 (cont'). Streamwise Velocity Data for 3.5 and 4 cfs (station 4).

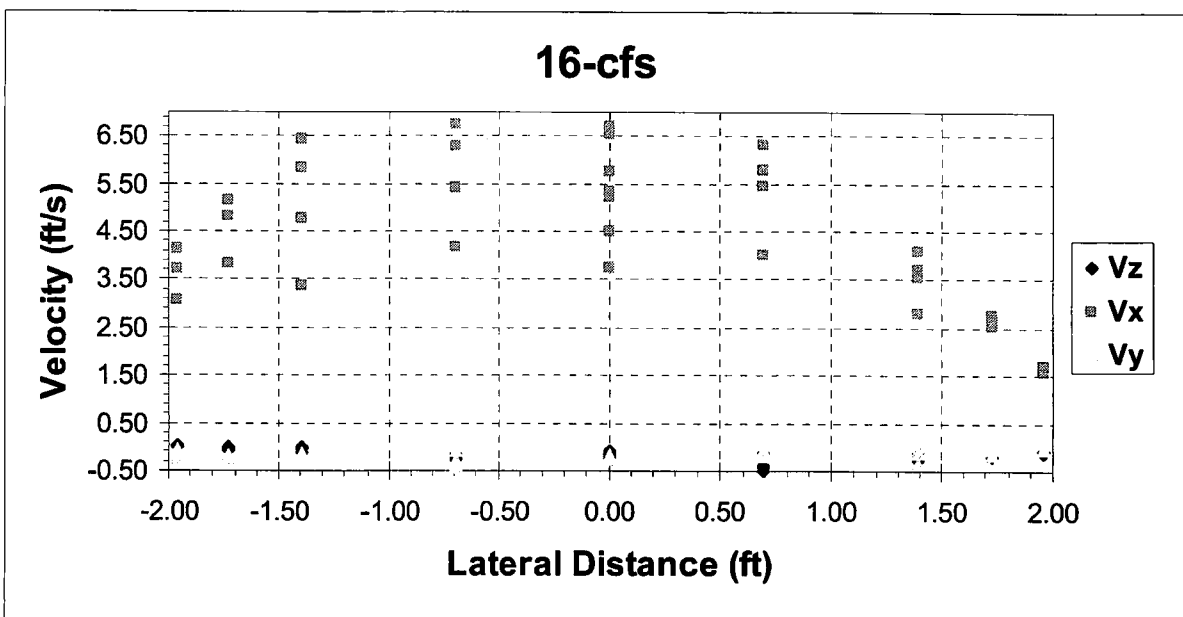
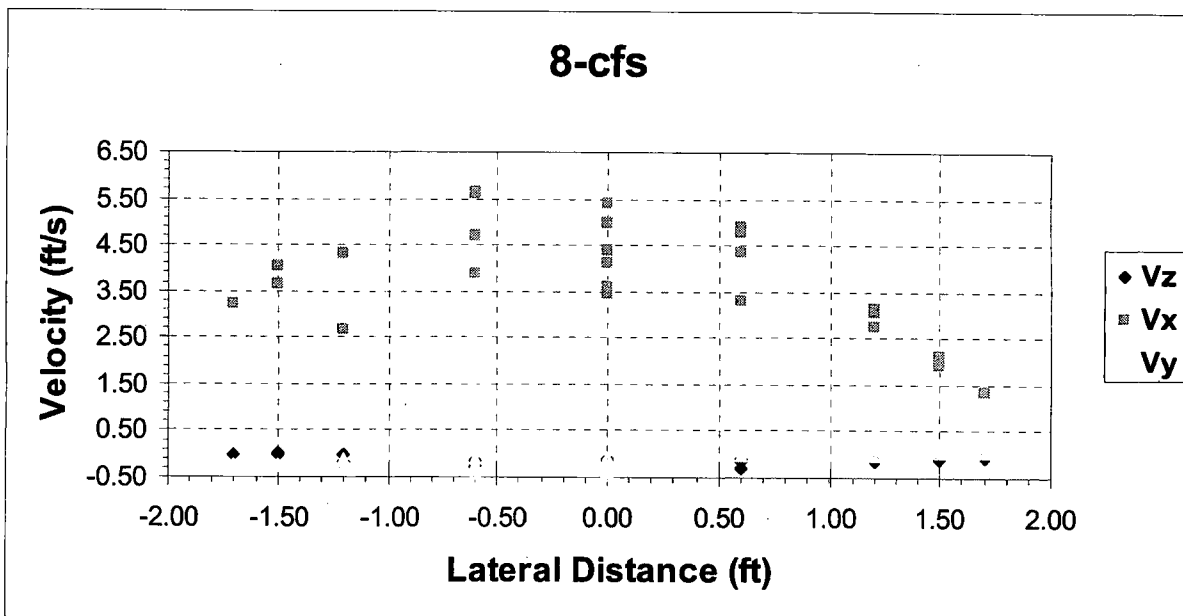
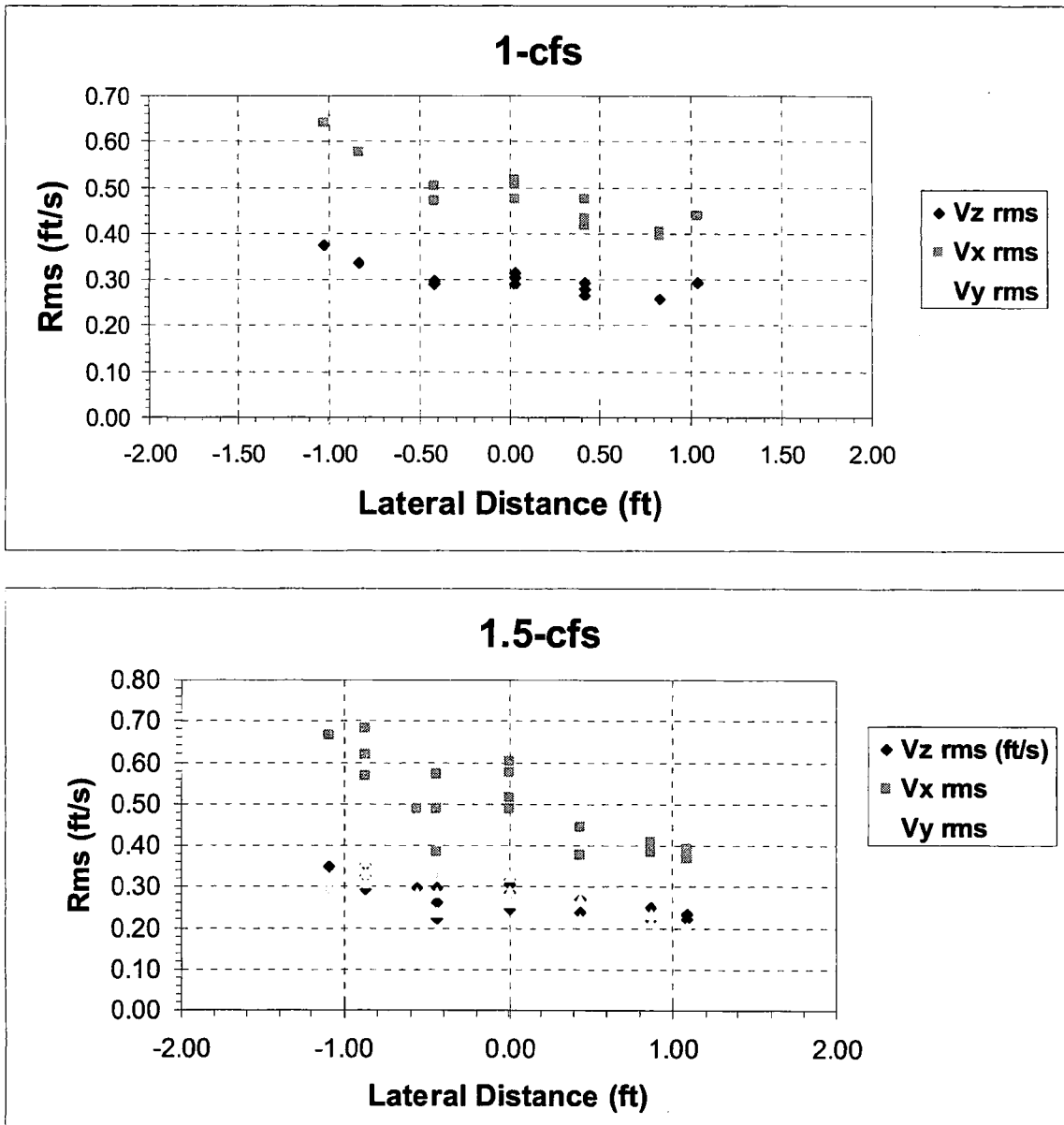


Figure 22 (cont'). Streamwise Velocity Data for 8 and 16 cfs (station 4).

The stream-wise turbulence intensities (RMS values) also tended to be higher on the left side than on the right side of the culvert (Figure 23). In contrast to the velocity data, where  $V_z$  and  $V_y$  were minimal compared with  $V_x$ ,  $RMS_z$ , and  $RMS_y$  were of comparable magnitude to  $RMS_x$  at all flows, indicating that the velocity fluctuations in the non-stream-wise directions are large relative to the corresponding mean velocities. It is also notable that the stream-wise RMS values in the RVZ on the right remain fairly constant at around 0.5 ft/s at all flows and do not increase appreciably at higher flows (Figure 23).



**Figure 23.** Turbulence Intensities (RMS) at 1 (station 3) and 1.5 (station 4) cfs. Station 3 (16.4 ft downstream) was used instead of station 4 (23.5 ft downstream) at 1 cfs to be upstream of the backwater effects; measurements for all discharges except 1 cfs were at station 4. Figure 23 is continued on the following three pages.



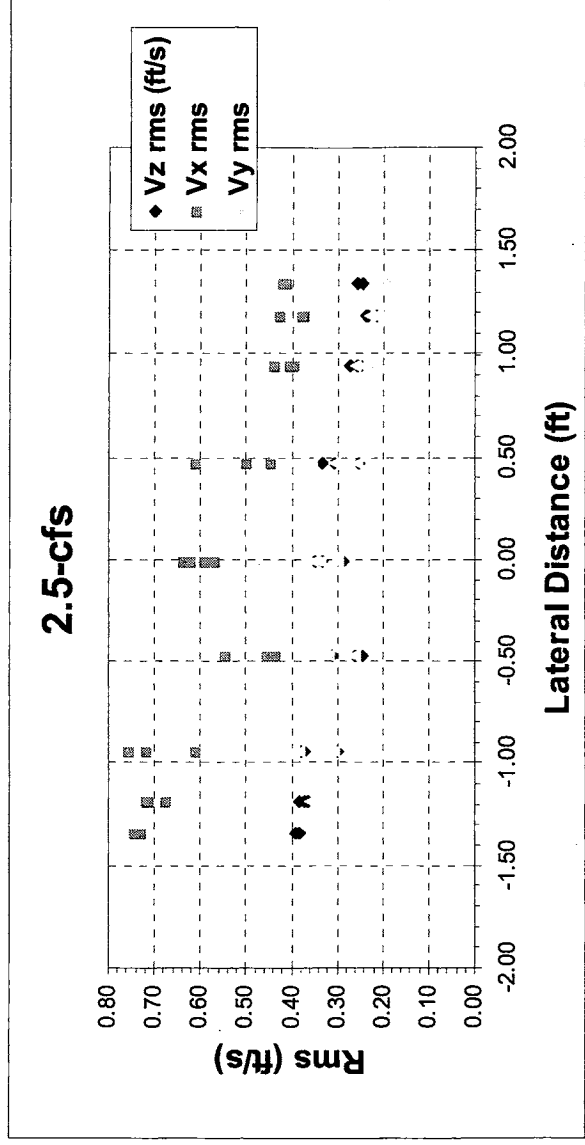
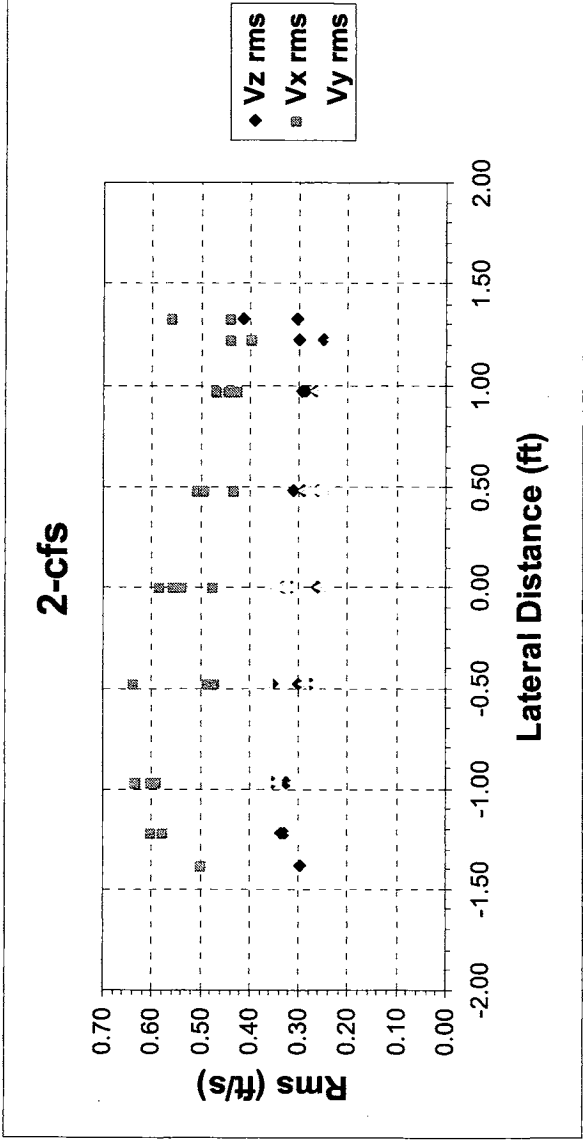


Figure 23 (cont'). Turbulence Intensities (RMS) at 2 and 2.5 (station 4).

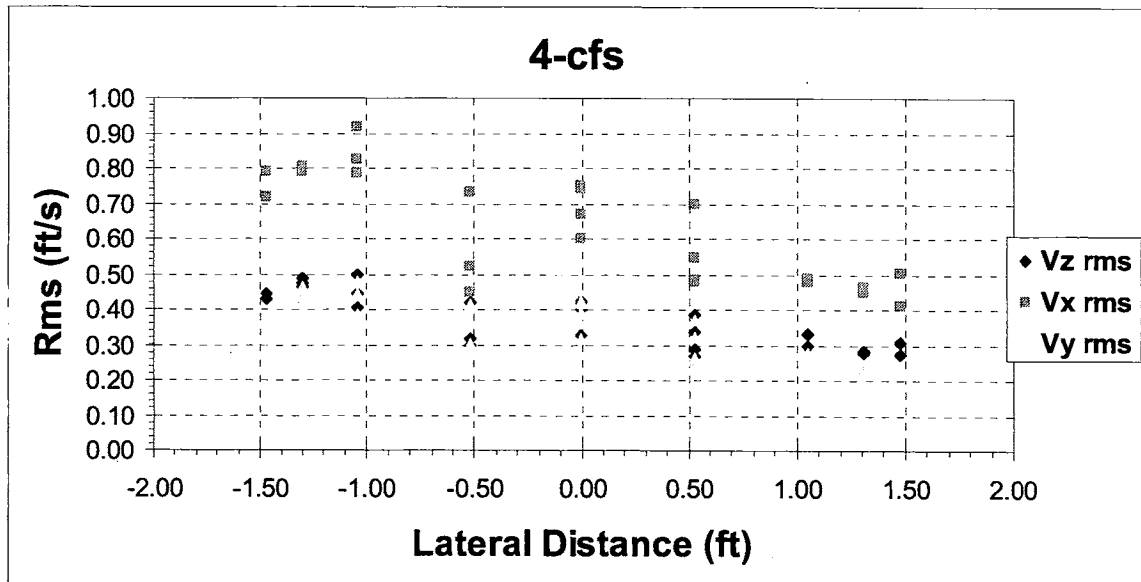
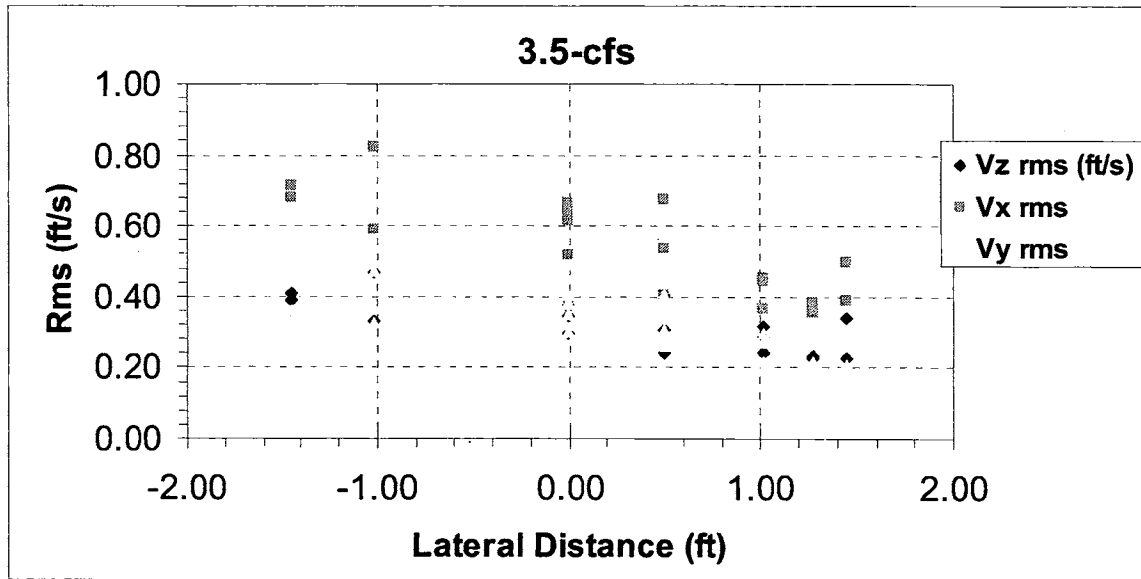


Figure 23 (cont'). Turbulence Intensities (RMS) at 3.5 and 4 cfs (station 4).

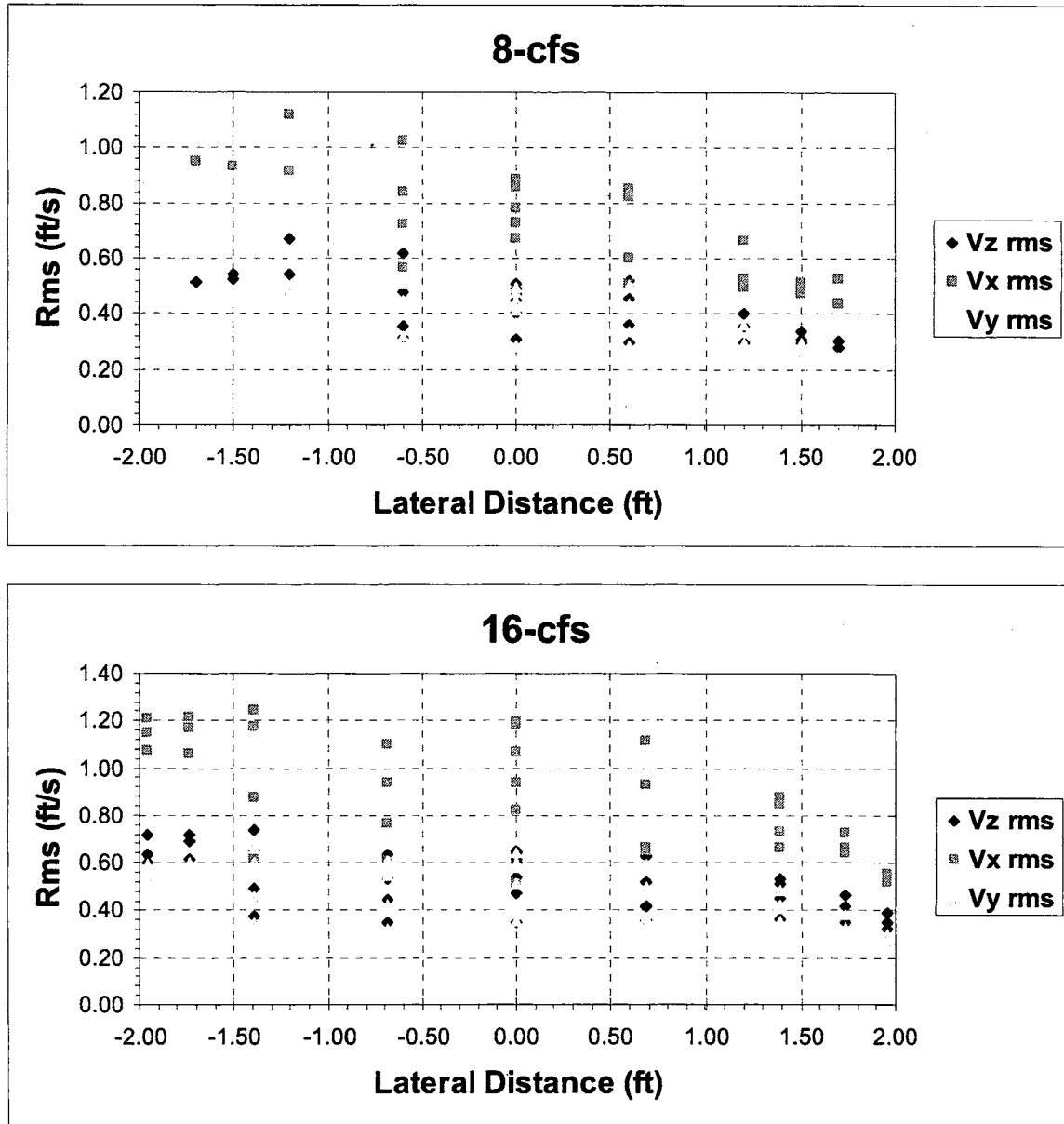
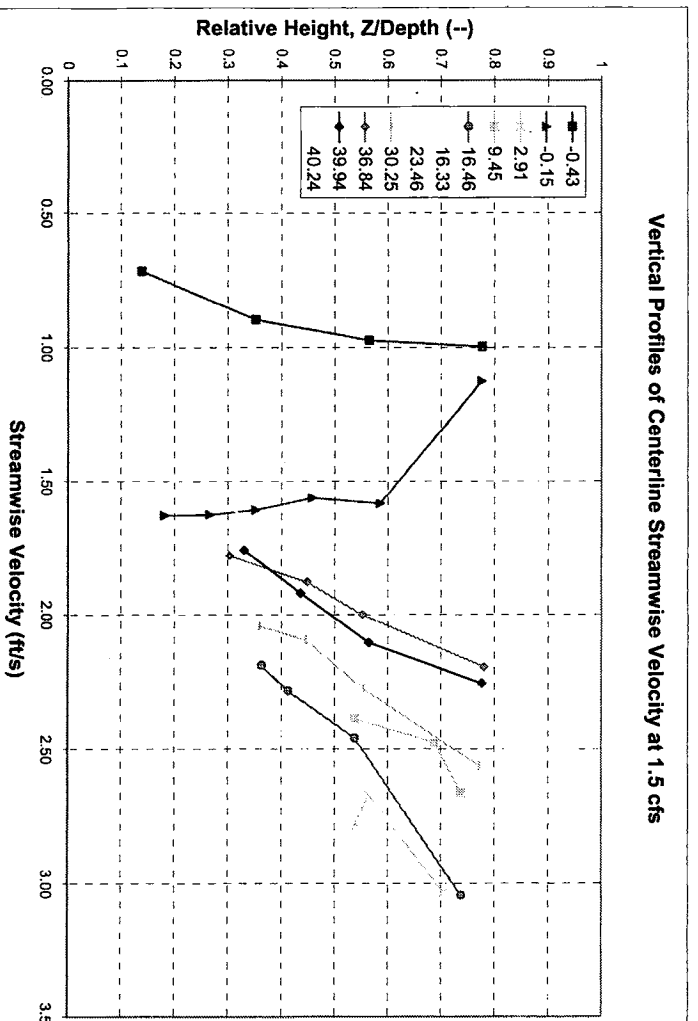
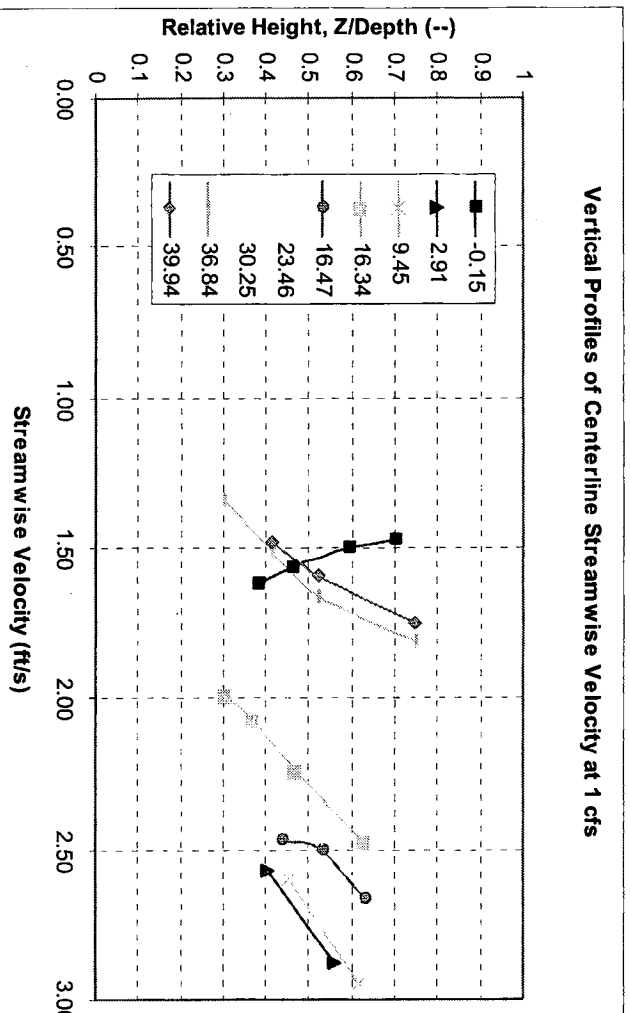


Figure 23 (cont'). Turbulence Intensities (RMS) at 8 and 16 cfs (station 4).

### 3.1.3 Vertical Profiles

Centerline vertical profiles are shown for each sampling location longitudinally down the culvert at each flow. The vertical profiles show that the 1- and 2-cfs flows never achieve true uniformity due to backwater effects that extend upstream (Figure 24) (Song and Chiew 2001). At 8 and 16 cfs, uniform flow occurs between 10 and 16 ft downstream from the culvert entrance. This observation is in general agreement with the findings of Ead et al. (2000), which indicated that uniform flow occurred at approximately two diameters downstream from the culvert entrance. The plots verify, however, that our fine grid of data collected at station 3 for 1 cfs and station 4 for 2 cfs is upstream of the backwater effect and as close to uniform as was attainable. The 4-cfs flow condition was less affected by the backwater condition and has sections where the

vertical profiles overlap, suggesting the flow is somewhat uniform (Figure 24) from 9 to 23 feet. Note that near-surface and near-bottom measurements were not collected because the arms on the side-looking ADV extend outward about 0.1 ft and, therefore, it cannot be positioned closer than that to the bottom or surface.



**Figure 24.** Vertical Velocity Profiles for Various Distances Down the Culvert at each 1.0 and 1.5 cfs. The numbers in the legend are the distance downstream from the culvert entrance for which the profiles were collected. Figure 24 is continued on the following three pages.

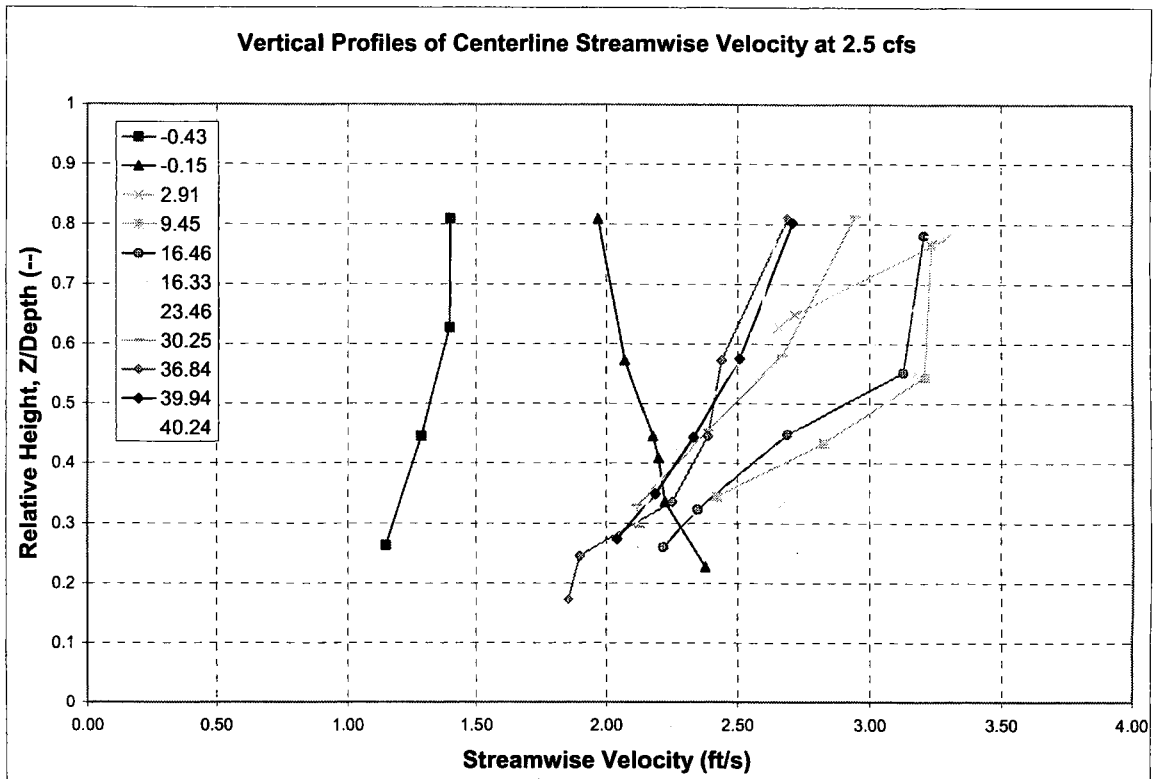
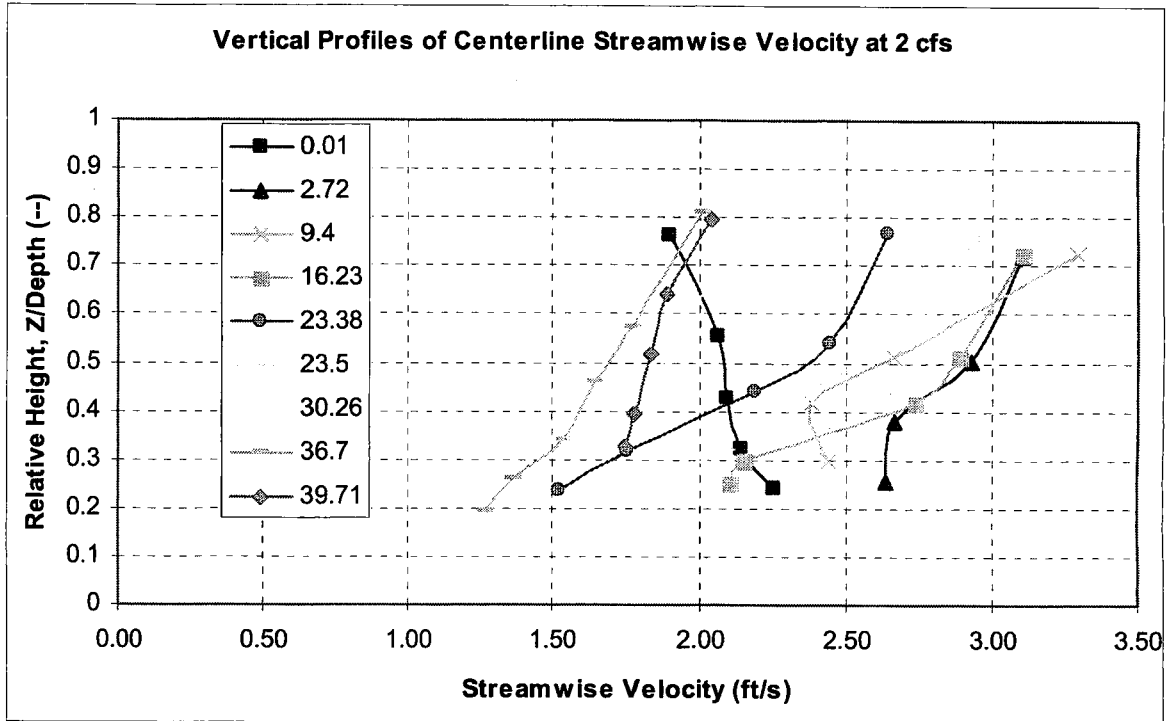
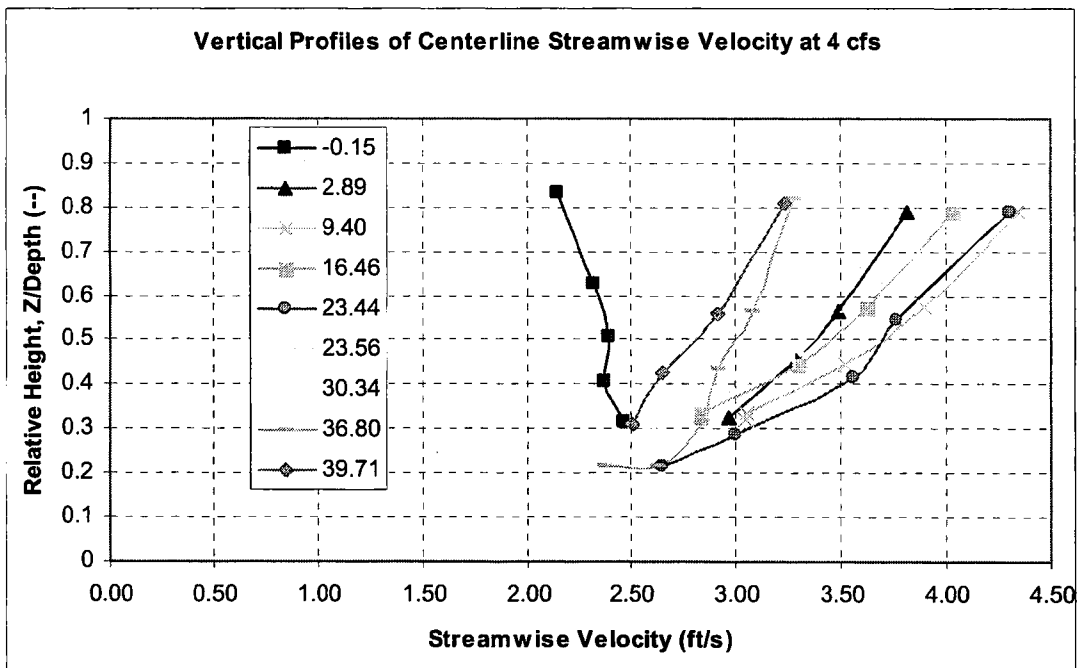
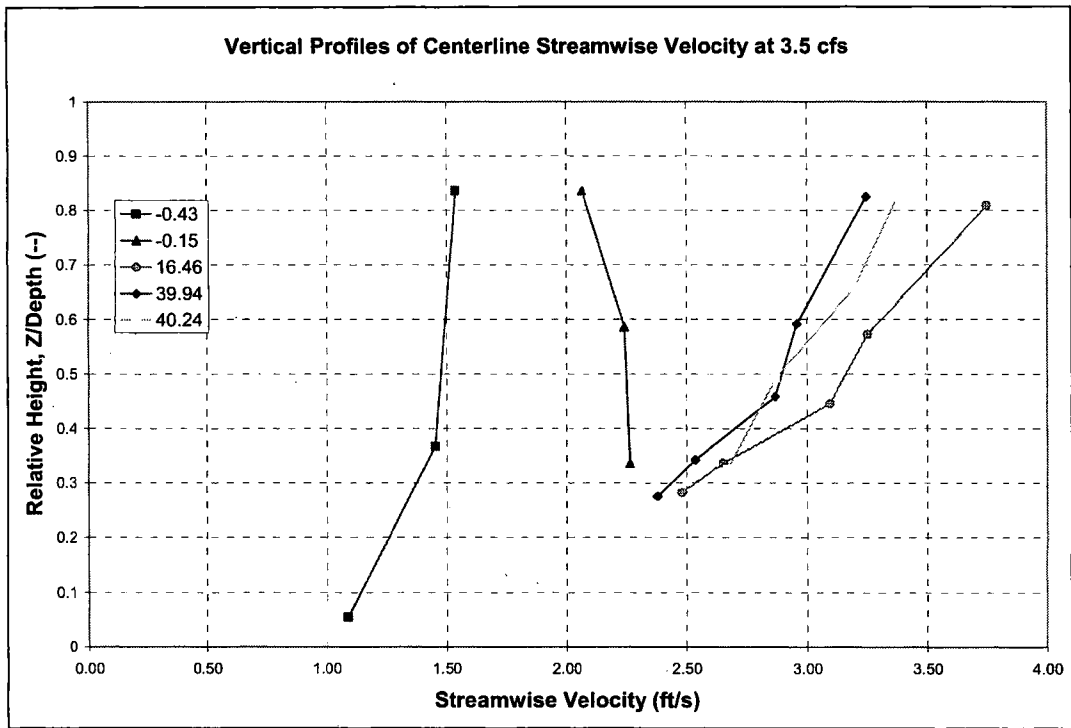
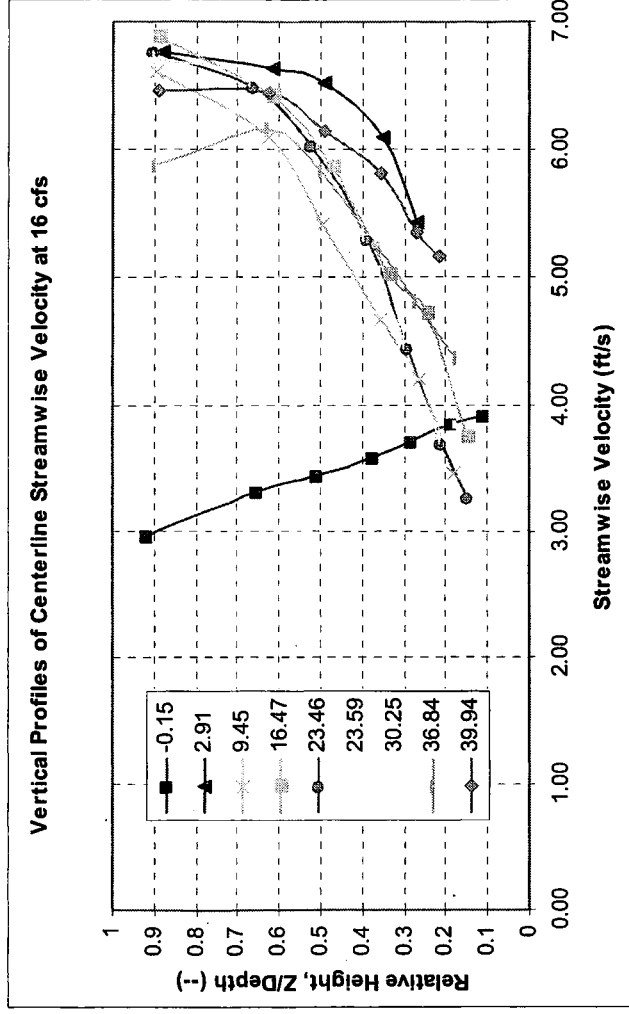
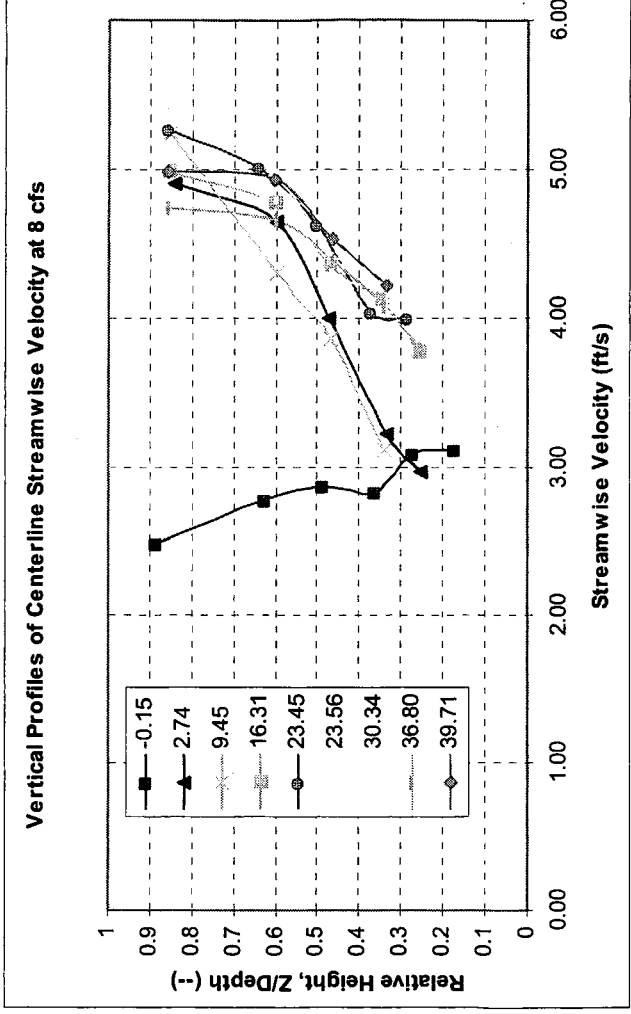


Figure 24 (cont'). Vertical velocity profiles for various distances down the culvert at 2.0 and 2.5 cfs. The numbers in the legend are the distance downstream from the culvert entrance for which the profiles were collected.



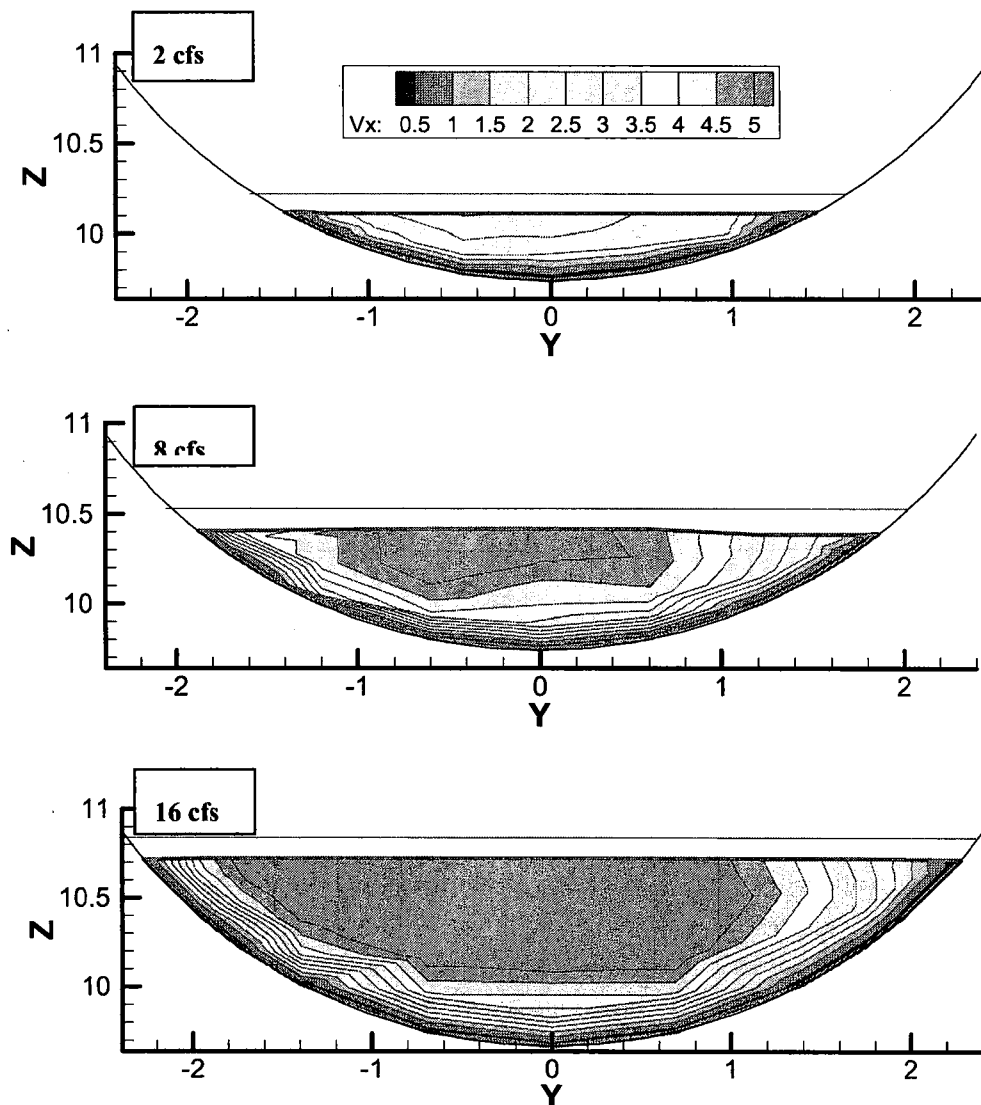
**Figure 24 (cont').** Vertical velocity profiles for various distances down the culvert at 3.5 and 4.0 cfs. The numbers in the legend are the distance downstream from the culvert entrance for which the profiles were collected.



**Figure 24 (cont').** Vertical Velocity Profiles for Various Distances Down the Culvert at 8 and 16 cfs. The numbers in the legend are the distance downstream from the culvert entrance for which the profiles were collected.

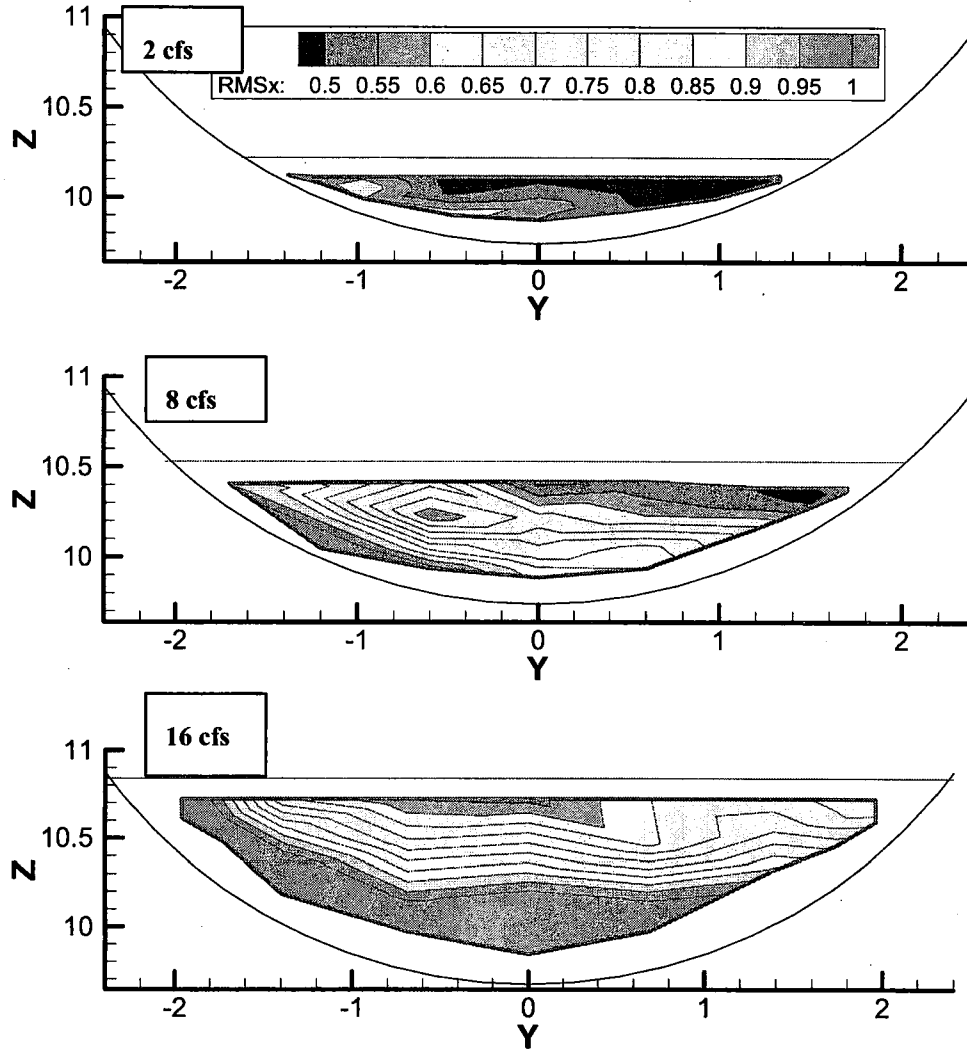
### 3.1.4 Cross-Sectional Profiles

Contour plots of the fine grid of cross-section data illustrate the stream-wise component of the velocity and RMS distributions. At all discharges measured, the stream-wise velocity (Figure 25) and turbulence-intensity (Figure 26) distributions were skewed toward the left side of the culvert (looking upstream) due to the angle of the spiral corrugations. This distribution suggests that the RVZ in the upper-right corner of the flow area in the culvert might provide the easiest fish passage route (i.e., lowest mean velocity and least turbulence) (Powers et al. 1997). The exception to this relationship occurred at the culvert inlet (HW tank), where contraction of the incoming flow created vortices and flow separation in corner regions.



**Figure 25.** Contour Plots of Velocity (fps) Measured at 2, 8, and 16 cfs. The cross section is from the middle part of the culvert test bed.

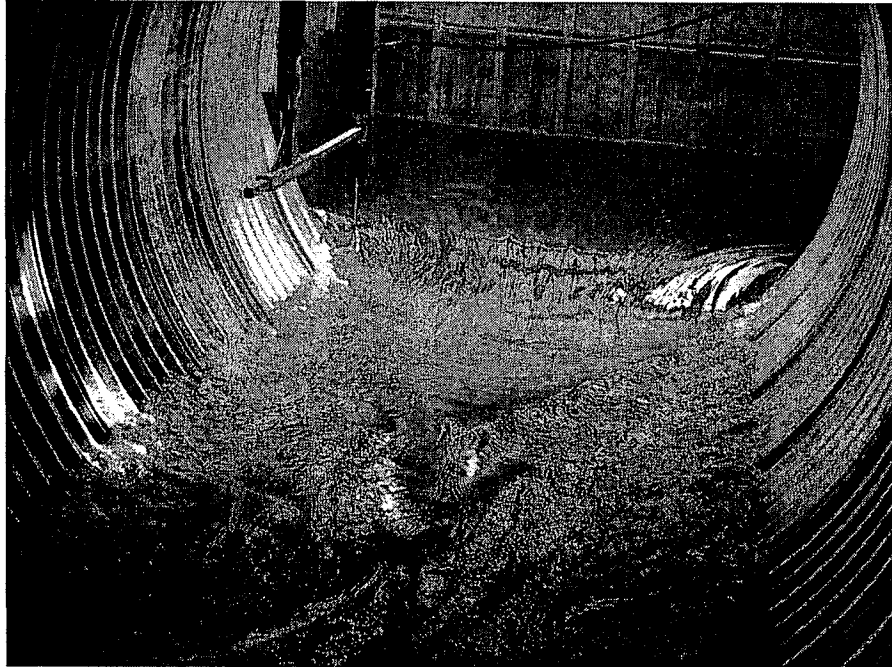




**Figure 26.** Contour Plots of Turbulence Intensity (fps) Measured at 2, 8, and 16 cfs. The cross section is from the middle part of the culvert test bed.

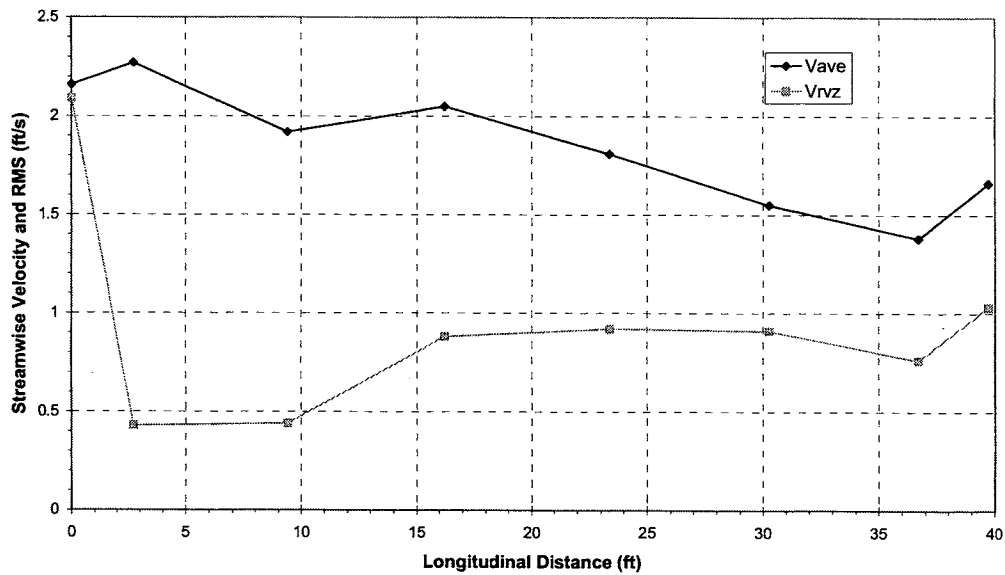
### 3.1.5 Longitudinal Profiles

Longitudinal profiles of the velocity and RMS show that the velocity in the RVZ was less than the overall average velocity throughout the culvert with the exception of the culvert inlet (Figures 27-31). The RMS in the RVZ was also typically less than the overall average at a cross section with the exception of the very upstream end of the culvert where inlet conditions (converging flow, flow separation, inlet drop) created turbulent conditions at the sides (Figures 27, 29, and 31).



**Figure 27.** Picture of the Flow Conditions at the Culvert Inlet. Note that the reduced velocity zones at the culvert edges disappear near the culvert inlet at the HW tank.

**Longitudinal Profiles of Streamwise Velocity at 2cfs**



**Figure 28.** Longitudinal Profiles of Stream-wise Velocity ( $V_x$ ). They compare the average velocity to the velocity in the RVZ ( $V_{rvz}$ ) at 2 cfs

Longitudinal Profiles of Streamwise RMS at 2cfs

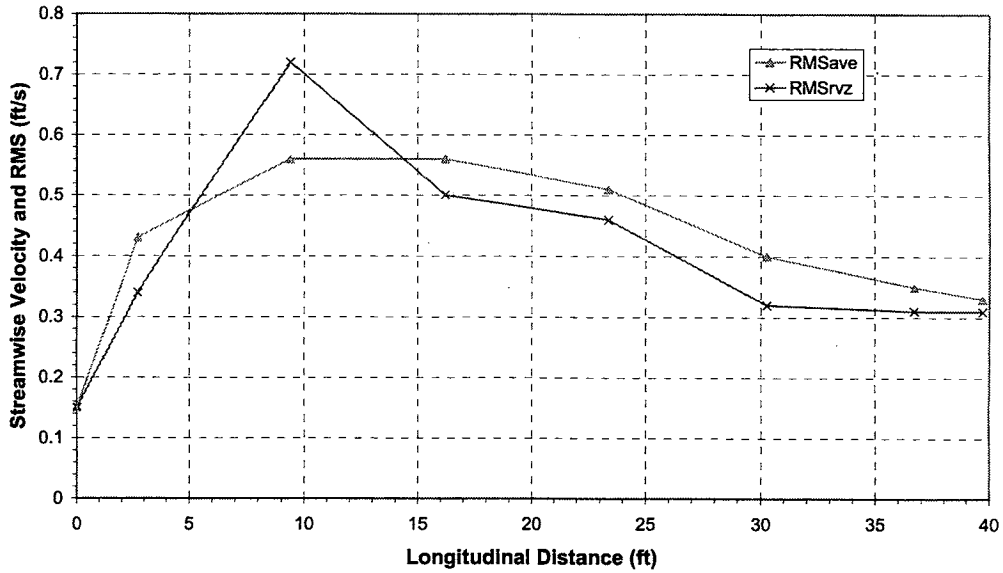


Figure 29. Longitudinal Profiles of Stream-wise RMS (turbulence intensity) at 2 cfs.

Longitudinal Profiles of Streamwise Velocity for 16cfs

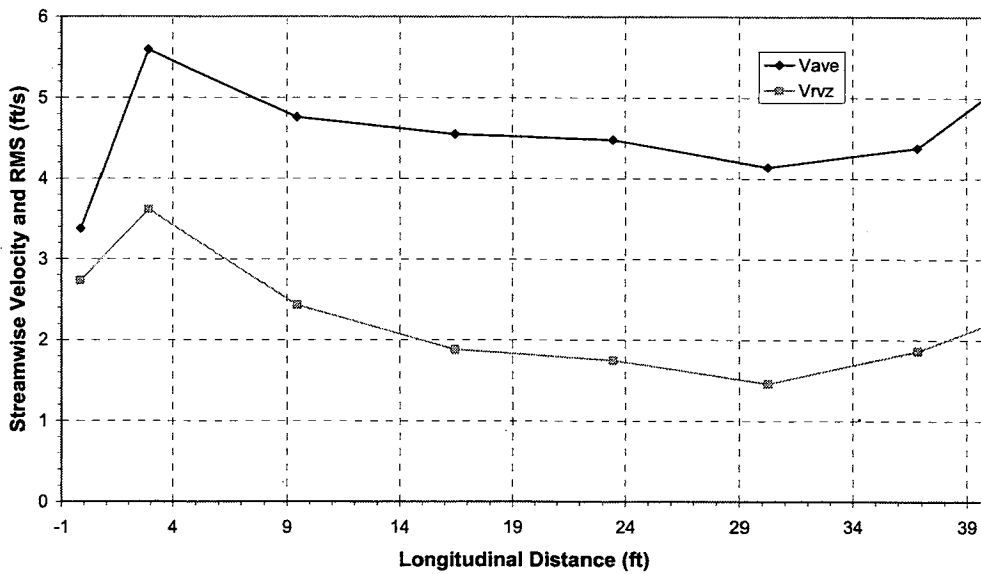


Figure 30. Longitudinal Profiles of Stream-wise Velocity (Vx). They compare the average velocity to the velocity in the RVZ (Vrvz) at 16 cfs

Longitudinal Profiles of Streamwise RMS for 16cfs

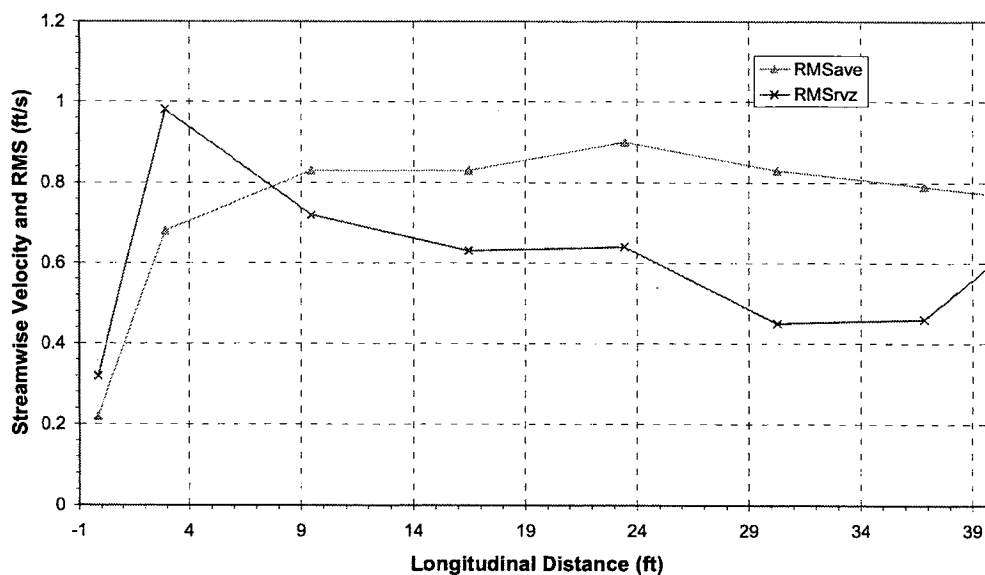


Figure 31. Longitudinal Profiles of Stream-wise RMS (turbulence intensity) at 16 cfs

### 3.1.6 Relationships between Hydraulic Parameters

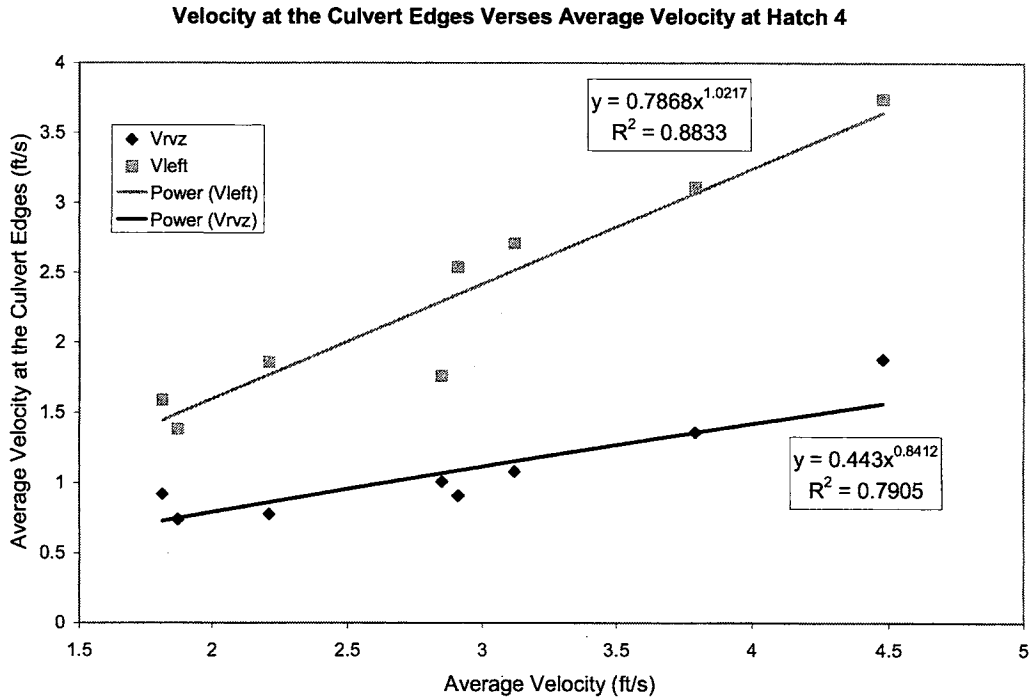
To examine relationships between the average velocity, which is proportional to the discharge, and other parameters of interest, the regressions in Figures 32-34 were performed for hydraulic data collected at station 4. The velocity in the RVZ was clearly less than the velocity in the corner region on the left side of the culvert as seen looking upstream, and it increased less dramatically with increased average velocity (Figure 32). The regression suggests that, for the test culvert, average velocity can be reduced with the following expression to estimate the  $V_{rvz}$ .

$$V_{rvz} = 0.443 * V_{avg}^{0.8412}$$

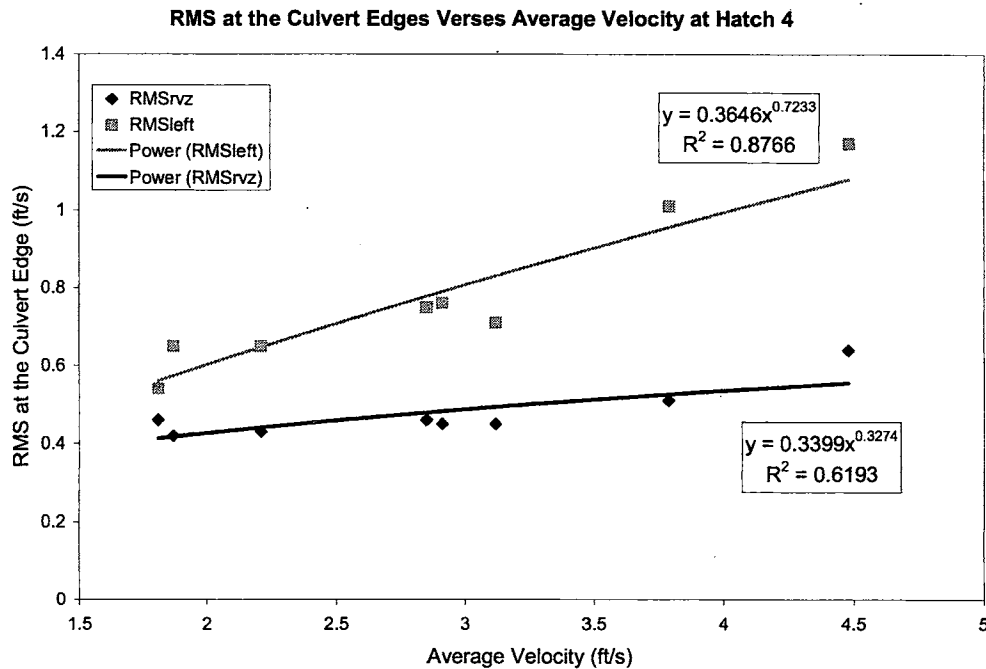
Likewise, the RMS velocity values in the RVZ are less than average and less than those observed in the region on the left side of the culvert flow (Figure 33). Additionally, the RMS values in the RVZ increase very little with increasing average velocity or flow and remain approximately 0.5 ft/s for the discharges measured. The following expression relates the RMS velocity in the RVZ to the average velocity for the test culvert and the range of discharges tested:

$$RMS_{rvz} = 0.3399 * V_{avg}^{0.3274}$$

Note that the expressions for  $V_{rvz}$  and  $RMS_{rvz}$  are empirical relationships for the particular culvert configuration tested and are not general formulas. More work is necessary to examine the effect of lower and higher flows and of changing configuration variables such as the slope, culvert size, bottom material, culvert shape and corrugation patterns.

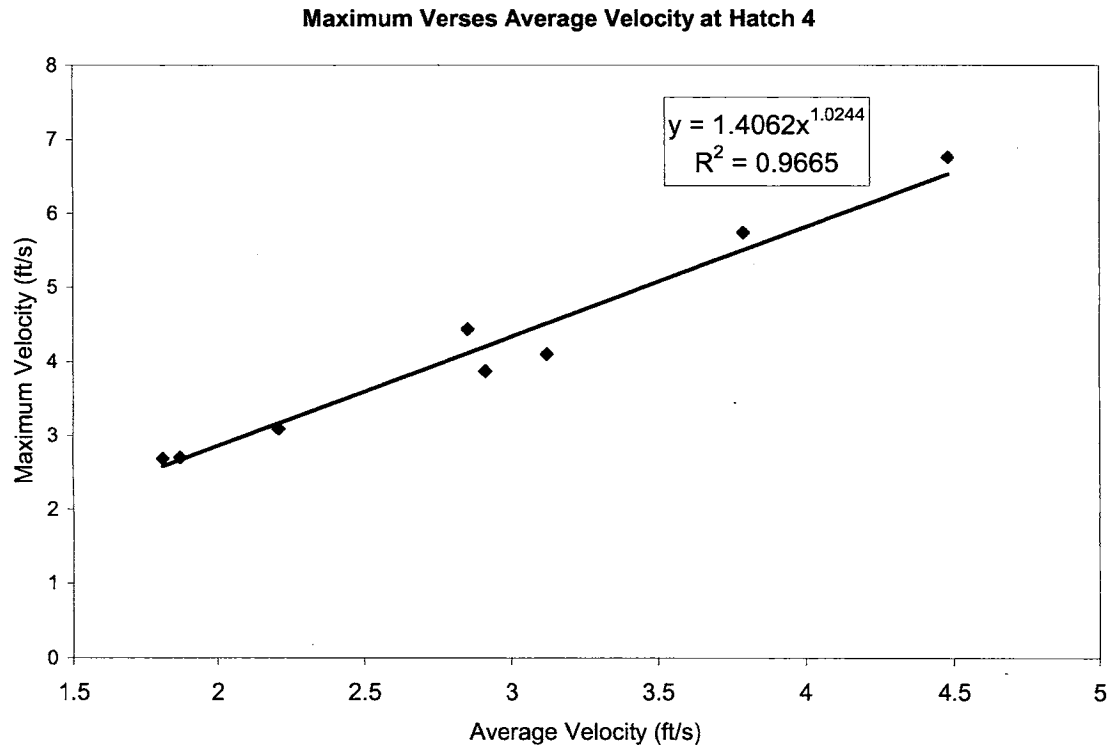


**Figure 32.** Edge Velocities versus Average Velocity (discharge/area). The plots show that the velocity in the RVZ is less than the corresponding velocity on the left side.



**Figure 33.** Edge RMS Values versus Average Velocity (discharge/area). The plots show that the RMS values in the RVZ increase minimally with increased velocity.

The reduced velocity and RMS on the right side of the culvert corresponded with the general observations of juvenile test fish migrating along the right edge of the culvert. With further investigation, these expressions may be useful in determining appropriate velocity and RMS velocity reduction factors. Lastly, the maximum velocity increased proportionally with the average velocity and appears to be generally about 1.5 times the average (Figure 34).



**Figure 34.** Maximum Velocity Measured at a Cross Section versus Average Velocity (Q/A).

## 3.2 Biological Tests

During the biological tests to develop protocols, we conducted focused experiments to resolve specific issues. We also evaluated and refined the protocols in tests using the baseline culvert, which also provided a biological characterization for the baseline culvert.

### 3.2.1 Protocol Development

We performed experiments to establish specific values for conditions to be set in the protocols. The first experiment was designed to validate the basic methods described above, including the TW net pen apparatus. The objectives of other experiments were to determine the evaluation conditions regarding 1) basic methods, 2) time of day and shading; 3) backwatering; 4) tailwater pool depth; and 5) test fish density in tailwater pool.

### 3.2.1.1 Validation of Basic Methods, Including Net Pen

Seven preliminary tests were conducted with large fish between April 8 and April 15, 2003 (Table 6). Four were conducted overnight, one during dusk, and two during daylight. Test duration was not standardized and the data were not normalized for test-duration. Duration for overnight tests ranged from 7.5 h to 17 h; the longer night test periods included some day and dusk periods also. The day tests were 4 h and 6 h long and the dusk test was 4 h long. Tests were conducted with 20 fish per test. In total, 140 large juvenile coho salmon were tested.

**Table 6.** Test Conditions for Focused Experiments for Protocol Development for Validation of Basic Methods in April 8-16, 2003 at the CTB.

Date	Test ID	Period	Fish Size	N	Duration (h)	Flow (cfs)	Shade	Temp (°C)	Comment
4/8	001	Day	Large	20	0.25	2	No	Not recorded	Assess integrity of TW net pen
4/8-9	002	Night	Large	20	16.5	2	No	Not recorded	Preliminary tests with larger coho salmon
4/9-10	003	Night	Large	20	17	2	No	Not recorded	Same, through Test ID 008
4/14	004	Day	Large	20	6	2	No	Not recorded	
4/14-15	005	Night	Large	20	9.5	2	No	Not recorded	
4/15	006	Day	Large	20	4	2	No	Not recorded	
4/15	007	Dusk	Large	20	4	2	No	7	
4/15-16	008	Night	Large	20	7.5	2	No	6.5	

Note: All tests were with a 6-ft round, bare, corrugated culvert at 1.14% slope. The distance from invert to net pen floor in TW was 10 in. Testing was with large juvenile coho salmon (mean FL 139 mm, range 104 mm to 177 mm).

The data indicated that more of these large juveniles (mean FL of 139 mm) moved upstream at night than at dusk or during day (Table 7) ( $P = 0.105$ ; Kruskal-Wallis test). The large fish that moved up the culvert had no difficulties entering or swimming upstream or exiting at the 2-cfs flow tested. For example, a test fish observed entering and exiting the culvert took 20 seconds to swim the 40-ft length of the culvert from the TW tank to the HW tank. Video observations revealed that a few fish exhibited fallback behavior once they entered the HW tank. These fish were not counted in the passage success metric because they were not in the HW tank at the end of the test. The protocols for the basic methods were validated and the TW net pen worked well.

**Table 7.** Summary Results from Focused Experiments on Validation of Basic Methods during April 8-16, 2003. Test conditions are described in Table 6.

Test Period	Number of Tests	Number of Fish in TW Tank	Number of Fish in Culvert	Number of Fish in HW Tank	Passage Success (%)
Day	2	33	0	7	17.5
Dusk	1	17	0	3	15.0
Night	4	12	0	47	79.7

Note: The tests used large juvenile coho salmon (mean FL=139 mm). Passage Success (%) = 100 \* (Number in HW at end of test divided by total number released).

### 3.2.1.2 Time of Day and Shading

During work to develop protocols from April 22 to May 9, 2003 (Tests 010-024, 026-028, Table 8), six tests were conducted during the day (three with canvas over the HW and TW tanks and hatches), six tests at dusk (three with canvas), and six tests overnight (three with canvas). The day and dusk tests were each 3 hours in duration. The overnight tests ranged from 8 h to 10.5 h in duration. All tests were conducted with 20 fish per test. In total, 480 small juvenile coho salmon were tested (this includes a preliminary test to ensure the net pen could contain the small fish and a shorter daylight test with a greater density of fish).

The data from Tests 010-024 and 026-028 indicated that the fish moved upstream at night rather than during dusk or day periods (Table 9). The difference in passage success between day and night was statistically significant ( $P = 0.038$ ; Kruskal-Wallis test). Although the night tests were about three times as long as the day tests, the fish were generally more active and showed a higher proclivity to move upstream during night than during day based on visual observations during testing. There was little or no difference in passage success when the end tanks were covered with the canvas versus when the tanks were not covered (shaded) (Table 9).



**Table 8.** Test Conditions for Focused experiments for Protocol Development on Time of Day and Shading in April 22 to May 9, 2003 at the CTB.

Date	Test ID	Period	N	Duration (h)	Flow (cfs)	Shade	Temp (°C)	Comment
4/22	009	Day	20	1	2	No	7	Assess integrity TW net-pen
4/22	010	Day	20	3	2	No	7	Prelim. tests w/ sm. coho
4/22	011	Dusk	20	3	2	No	7.5	
4/22-23	012	Night	20	8.5	2	No	7	
4/23	013	Day	20	3	2	No	not recorded	
4/23	014	Dusk	20	3	2	No	7	
4/23-24	015	Night	20	8.5	2	No	7	
4/24	016	Day	20	3	2	Yes	7	
4/24	017	Dusk	20	3	2	Yes	7	
4/24-25	018	Night	20	10	2	Yes	not recorded	
5/6	019	Day	20	3	2	No	8	
5/6	020	Dusk	20	3	2	Yes	8	
5/6-7	021	Night	20	8	2	Yes	7	
5/7	022	Day	20	3	2	Yes	7	
5/7	023	Dusk	20	3	2	Yes	7	
5/7-8	024	Night	20	8.5	2	Yes	7.9	
5/8	025	Day	100	2	2	Yes	8	
5/8	026	Day	20	3	2	Yes	8	
5/8	027	Dusk	20	3	2	No	8	
5/8-9	028	Night	20	8	2	No	7	

Note: All tests were with a 6-ft round, bare corrugated culvert at 1.14% slope. The distance from invert to net pen floor in TW was 10 in. Tests were with small juvenile coho salmon (mean FL 55 mm, range 40 to 62 mm).

**Table 9.** Summary Results from Focused Experiments for Protocol Development on Time of Day and Shading in April 22 to May 9, 2003 at the CTB. Test conditions are described in Table 8.

Test Period	Canvas Shade	Number of Tests	Number of Fish in TW Tank	Number of Fish in Culvert	Number of Fish in HW Tank	Passage Success (%)
Day	No	3	58	0	2	3.3
	Yes	3	59	0	1	1.7
Dusk	No	3	51	2	6	10.2
	Yes	3	56	0	4	6.7
Night	No	3	40	6	13	22.0
	Yes	3	44	2	14	23.3

Note: Tests were with small juvenile coho salmon (mean FL 55 mm, range 40 to 62 mm). Twenty fish were released per test.

### 3.2.1.3 Backwatering

During May 19-23, 2003, two tests (029 and 030) were designed to create benign passage conditions (Table 10). The approach was to completely backwater<sup>3</sup> the culvert using a low discharge (2 cfs), thereby creating low water velocities within the culvert.

The data indicated that passage success was not affected by extreme backwatering (Table 11). More fish were retrieved from the culvert barrel during these tests than previous tests, indicating some redistribution of fish within the available habitat; however, there was not a demonstrable increase in movement upstream into the headwater tank when the culvert was extremely backwatered. Next, the backwatering extent was returned to its initial value and tests at 2-cfs and 4-cfs were performed. Passage success for both tests (031 and 032) was zero (Table 11).

Subsequent tests (033-035, Table 10) explored the use of light cues to stimulate motivation because video observations indicated few fish attempted to enter the culvert. Artificial light was introduced to the TW tank during a night test by placing three 250-watt flood lamps above the water. The entire net-pen was illuminated for a 2-h period. An initial startle response was observed when the lights were first activated, but the fish soon returned to milling type behavior. Passage success was zero (Table 11) for the test with white light in the TW tank (Test 033). Alternately, white light was used to illuminate the HW tank and at the upper portion of the culvert. This test (034) also at night resulted in 10% passage success (Table 11).

<sup>3</sup> Backwatering occurs when the water surface elevation in the tailwater tank extends upstream into the culvert.

**Table 10.** Test Conditions for Focused Experiments for Protocol Development on Backwatering in May 19-22, 2003 at the CTB. Note: All tests were with a 6-ft round, bare corrugated culvert at 1.14% slope. The distance from invert to net pen floor in TW was 10 in. Tests used small juvenile coho salmon (mean FL 55 mm, range 40-62 mm).

Date	Test ID	Period	Fish Size	N	Duration (h)	Flow (cfs)	Shade	Temp (°C)	Comment
5/19-20	029	Night	Small	20	3	2	No	8	Complete backwater
5/19-20	030	Night	Small	20	3	2	No	8	Complete backwater
5/20-21	031	Night	Small	20	8	2	No	8	2-cfs
5/20-21	032	Night	Small	20	3	4	No	8	4-cfs
5/21-22	033	Night	Small	20	2	2	No	8	White light in TW tank
5/21-22	034	Night	Small	20	3	2	No	8	White light in HW tank
5/22-23	035	Night	Small	300	3	1.5	No	8	High density to simulate crowding and lower flow

**Table 11.** Summary Results from Focused Experiments for Protocol Development on Backwatering during May 19-22, 2003 at the CTB. All test were at night with 20 fish each, except for the last which had 300 fish. Test conditions are described in Table 10.

Number of Tests	Number of Fish in TW Tank	Number of Fish in Culvert	Number of Fish in HW Tank	Passage Success (%)	Comments
1	12	5	3	15.0	Extreme backwater (2 cfs)
1	14	5	1	5.0	Extreme backwater (2 cfs)
1	20	0	0	0	Normal conditions (2 cfs)
1	20	0	0	0	Greater flow (4 cfs)
1	20	0	0	0	White light in TW (2 cfs)
1	18	0	2	10.0	White light in HW (2 cfs)
1	242	3	55	18.3	High density and lower flow (1.5 cfs)

Note: Tests were with small juvenile coho salmon (mean FL 55 mm, range 40 to 62 mm).

In the final test (035), the number of fish released into the TW tank was increased from 20 to 300 fish to simulate crowding as a motivating factor for upstream movement (Table 10). About 1 h into this test, workers checked the flow level and realized that they could attain 1.5 cfs instead of the 2-cfs minimum for previous tests. Although changing these two variables at the same time produced a confounding situation, the decision was made to proceed with the test because of the

exploratory nature of the work. In future tests, only one variable at a time will be changed. The high-density test resulted in 18.3% passage success and a new minimum flow level for the CTB (Table 11).

In general, the most common behaviors observed on the video monitor in real-time were milling and feeding in the TW tank. A limited amount of territorial/aggressive behavior was observed and it was more prevalent during day than night. Because some fish established territories near the culvert entrance (based on observed antagonistic behavior), the opportunity for other fish to approach the culvert entrance could have been impeded. During the dusk and dark periods, fish were occasionally observed schooling. During several tests, the fish entered the culvert briefly (1 to 2 sec) before being washed out. Other fish entered the culvert and stayed there for some time or swam to the HW tank. Small fish were twice observed swimming from the TW to the HW tank. One fish swam the distance in 2.5 min, the other in 4 min. Unfortunately, their swimming location in the culvert barrel could not be observed during tests 9-28, so we do not know whether these fish used the presumed RVZ, as hypothesized. One observation of fallback from the HW tank to the TW tank was observed on video during dusk with canvas test. (Section 3.2.5 contains additional observations of fish behaviors.)

#### 3.2.1.4 Tailwater Pool Bottom Distance from Culvert Invert

In November 2004, we continued protocol development with tailwater pool depth<sup>(4)</sup> and fish density as experimental factors. All other factors were held constant. The tests were conducted at the same baseline CTB configuration that was used in 2003. The primary response variable was passage success, defined above. Additional factors held constant during pool depth and fish density testing included the following: discharge – 1.5 cfs; backwater – ~25%; hiding structures – none; test period – night; and duration – 3 h. Discharge was constant at 1.5 cfs as opposed to 2.0 cfs in baseline tests in 2003 because the 1.5-cfs condition had the highest passage success in 2003 baseline tests. Discharge is an experimental variable, not a standard condition. Backwater at 25% meant that the water surface was level from the TW tank 25% of the distance up the culvert barrel, i.e., about 10 ft. Backwater is measured by recording water levels on the manometer board. In 2004, three pool distances (Figure 35) were tested (Table 12):

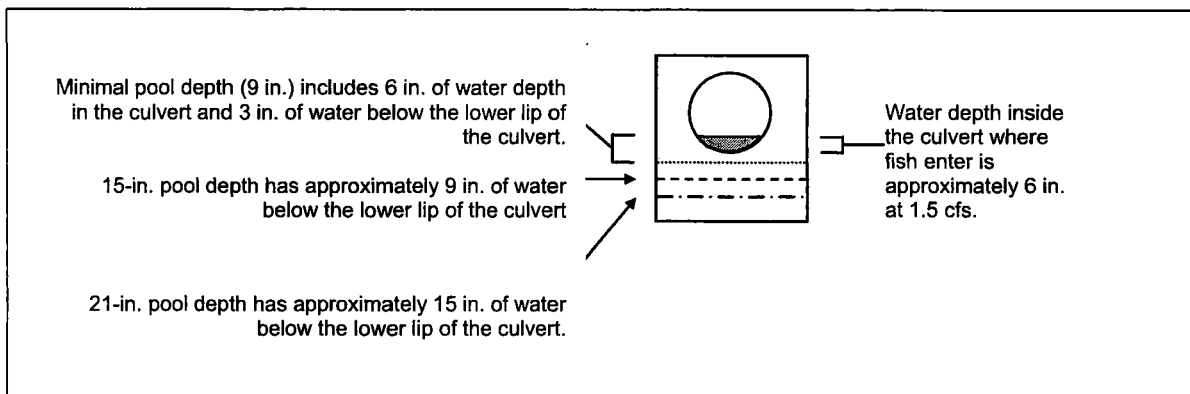
- 9 in. – Shallow pool depth; this equates to approximately 3 in of water between the floor of the net pen and the lowest part of the culvert entrance. Water depth inside the culvert is approximately 6 in at 1.5 cfs.
- 15 in. – Middle pool depth: this was the pool depth in 2003 for 1.5 cfs tests; this equates to approximately 9 in. of water between the floor of the net pen and the lowest part of the culvert entrance.
- 21 in. – Deep pool depth; this equates to approximately 15 in of water between the floor of the net pen and the lowest part of the culvert entrance.

---

<sup>(4)</sup> Pool depth is the distance from the floor of the net pen to the water surface at the culvert outlet.

On any given test-night, it was possible to run a maximum of two tests. The first test was initiated under full darkness (after 1830 h). The second test was initiated as soon as practicable, following completion of the first test. The second test was always terminated before daybreak (usually ~ 0300h). The order of the factor levels for testing was randomized without replacement. Two paired series of tests were performed over consecutive nights (Table 12). Thus, each level of pool depth was tested four times. The number of fish tested was adjusted according to the pool depth, keeping the density of fish in the net pen constant at 2 fish/ft<sup>3</sup> at test initiation, based on the water volume available to fish inside the net pen.

A total of 2400 fish were tested. A subset of fish was measured following each test, up to a maximum of 20 fish from each of the three culvert sections. Average fork-length was 92.5 mm with a range of 61 to 122 mm. The fish recaptured in the HW tank did not differ greatly in size from those that were recaptured in the TW tank and culvert (Table 13).



**Figure 35.** TW Tank Showing Pool Depths. Front view looking upstream.

**Table 12.** Test Conditions for Focused Experiments for Protocol Development on Pool Depth in November 8-13, 2004 at the CTB

Date (2004)	Test ID.	Temp. (°C)	Pool Depth	Pool Volume	Number of Fish Tested
November 8	1	7	15 in	100 ft <sup>3</sup>	200
	2	7	(middle)		
November 9	3	Not rec.	21 in	140 ft <sup>3</sup>	280
	4	7	(deep)		
November 10	5	8	9 in	60 ft <sup>3</sup>	120
	6	8	(shallow)		
November 11	7	6.5	9 in	60 ft <sup>3</sup>	120
	8	6	(shallow)		
November 12	9	6.5	21 in	140 ft <sup>3</sup>	280
	10	6.5	(deep)		
November 13	11	Not rec.	15 in	100 ft <sup>3</sup>	200
	12	Not rec.	(middle)		

Note: Testing in 2004 utilized mid-sized juvenile coho (mean FL 93.4 mm, range 61 to 126 mm).

**Table 13.** Mean, Minimum, and Maximum Fish Sizes (Fork Length, FL) during Pool Depth Tests in November 2004. Test conditions are described in Table 12.

	Mean FL (mm)	Minimum FL (mm)	Maximum FL (mm)
Overall (n=40)	92.5	61	122
Fish Recaptured in the HW Tank (n=20)	93.6	68	122
Fish Recaptured in the Culvert and TW Tank (n=20)	91.8	61	122

Passage success decreased as pool depth increased (Table 14). Mean percentage of passage was 39.2%, 23.8%, and 2.3% for the shallow, middle, and deep pools, respectively. Statistical analyses were performed on these data. Because there was a significant difference between pool depths ( $P=0.012$ ; Kruskal-Wallis test), the shallow pool depth (9 in.) was used to conduct the baseline culvert evaluation of the relationship between passage success and initial TW tank fish density.

It is interesting that pairs of results on a given night are similar, but differ from those on another night for the same conditions (Table 14). Water temperature ranged from 6 °C to 8 °C. Weather was usually cloudy or partially cloudy.

**Table 14.** Summary Results from Focused Experiments for Protocol Development on Pool Depth in November 8-13, 2004 at the CTB. The data were sorted by relative pool depth, then by passage success with each pool depth. Test conditions are described in Table 12.

Test ID	Relative Pool Depth	Number of Fish in TW Tank	Number of Fish in Culvert	Number of Fish in HW Tank	Passage Success (%)
7	Shallow	57	1	63	52.1
8	Shallow	65	1	52	44.1
6	Shallow	75	3	42	35.0
5	Shallow	87	2	31	25.8
11	Middle	127	4	69	34.5
12	Middle	134	2	64	32.0
2	Middle	163	4	33	16.5
1	Middle	175	1	24	12.0
10	Deep	264	0	16	5.7
9	Deep	273	1	7	2.5
3	Deep	277	1	2	0.7
4	Deep	269	0	1	0.4

Note: (shallow = 9 in.; middle = 15 in.; deep = 21 in.) Testing in 2004 utilized mid-sized juvenile coho (mean FL 93.4 mm; range 61 to 126 mm).

### 3.2.1.5 Fish Density

Following the conclusion of the pool depth tests, three fish densities (fish/ft<sup>3</sup>) were tested. Tests were conducted at the pool depth that had the best passage success (i.e., shallow pool depth, 9 in.). The test protocol for fish density was similar to that used to test pool depth. However, tests were not paired on a nightly basis, as it was relatively simple to adjust the number of fish tested (as opposed to adjusting and ensuring the appropriate height of the net pen at night during the pool depth tests, which had been paired to avoid that complication). Two tests were performed over six consecutive nights so that the three fish densities were tested four times each (Table 15).

A total of 1680 fish were tested. A subset of fish was measured following each test (a maximum of 20 fish from each of the three culvert sections). Of these fish tested and measured, the average FL was 94.2 mm with a range of 62 mm to 126 mm. The fish recaptured in the HW tank did not differ greatly in size from those that were recaptured in the TW tank and culvert (Table 16).

Statistical analyses showed that passage success did not differ significantly among the fish densities tested ( $P=0.174$ ; Kruskal-Wallis test). The variability in passage success was large, although the overall mean percentage of passage indicates that there may be less fish passage at the highest density (mean passage success for low, middle, and high densities was 36.0%, 32.6%, and 12.6%, respectively) (Table 17).

**Table 15. Randomized Test Blocks for Fish Density Tests.**

Date (2004)	Test Period	Test ID.	Number of Fish Tested	Fish Density
November 15	1	13	120	2 fish/ft <sup>3</sup> (middle)
	2	14	240	4 fish/ft <sup>3</sup> (high)
November 16	1	15	60	1 fish/ft <sup>3</sup> (low)
	2	16	60	1 fish/ft <sup>3</sup> (low)
November 17	1	17	120	2 fish/ft <sup>3</sup> (middle)
	2	18	240	4 fish/ft <sup>3</sup> (high)
November 18	1	19	240	4 fish/ft <sup>3</sup> (high)
	2	20	60	1 fish/ft <sup>3</sup> (low)
November 19	1	21	240	4 fish/ft <sup>3</sup> (high)
	2	22	60	1 fish/ft <sup>3</sup> (low)
November 20	1	23	120	2 fish/ft <sup>3</sup> (middle)
	2	24	120	2 fish/ft <sup>3</sup> (middle)

Note: Testing in 2004 utilized mid-sized juvenile coho (mean FL 93.4 mm, range 61 to 126 mm).

**Table 16.** Mean, Minimum, and Maximum Fish Sizes (Fork Length, FL) During Pool-Depth Tests in November 2004. Test conditions are described in Table 13.

	Mean FL (mm)	Minimum FL (mm)	Maximum FL (mm)
Overall (n=40)	94.2	62	126
Fish Recaptured in the HW Tank (n=20)	95.3	63	126
Fish Recaptured in Culvert and TW Tank (n=20)	93.3	62	123

Note: Testing in 2004 utilized mid-sized juvenile coho (mean FL 93.4 mm, range 61 to 126 mm).

**Table 17.** Fish Passage Success Relative to Fish Density in November 2004 (low=1 fish/ft<sup>3</sup>; middle=2 fish/ft<sup>3</sup>; high=4 fish/ft<sup>3</sup>.) Test conditions are described in Table 13.

Test ID	Relative Fish Density	Number of Fish in TW Tank	Number of Fish in Culvert	Number of Fish in HW Tank	Passage Success (%)
13	Middle	70	1	49	40.8
14	High	155	7	78	32.5
15	Low	16	0	44	73.3
16	Low	39	0	20	33.9
17	Middle	48	3	69	57.5
18	High	206	27	6	2.5
19	High	207	4	29	12.1
20	Low	41	0	19	31.7
21	High	232	1	8	3.3
22	Low	56	1	3	5.0
23	Middle	102	2	15	12.6
24	Middle	96	1	23	19.2

Note: Testing in 2004 utilized mid-sized juvenile coho (mean FL 93.4 mm, range 61 to 126 mm).

### 3.2.2 *Baseline Characterization*

We evaluated the protocols developed in April/May 2003 in a biological characterization of the baseline culvert in late May 2003. (Baseline culvert conditions were described at the beginning of Section 3.) The biological baseline characterization had three objectives: 1) determine the relationship between passage success and culvert discharge; 2) determine the horizontal distribution of fish exiting the culvert into the HW tank; and 3) examine the relationship between passage success and hydraulic features (mean and maximum water velocity and turbulence).

#### 3.2.2.1 Relationship between Passage Success and Culvert Discharge

During biological tests May 27-30, 2003, we studied the relationship between fish passage success and culvert flow for small fish in the baseline culvert. The baseline culvert was 40 ft long, 6 ft round, spiral corrugated (3 in. x 1 in.) placed at 1.14% slope. The distance from the culvert invert to the floor of the net pen in the TW tank was 10 in. The test protocols were based



on the results of the exploratory work in previous test periods. Two tests were performed each night for three successive nights (tests 036-041; Table 18). Flow levels at 0.5-cfs increments from 1.0 to 3.5 cfs were randomly set for each test period. A total of 200 fish were used for each test.

Passage success (number in HW tank divided by number released in TW tank) decreased from 16% at 1.0 cfs to 3% at 1.5 cfs and remained below 3% up to 3.5 cfs when it decreased to 0.5 % (Figure 36). The fish that did pass upstream successfully were generally observed on the far right side of the culvert (looking upstream) (Section 3.2.5).

**Table 18.** Biological Baseline Characterization in May 27-30, 2003 at the CTB

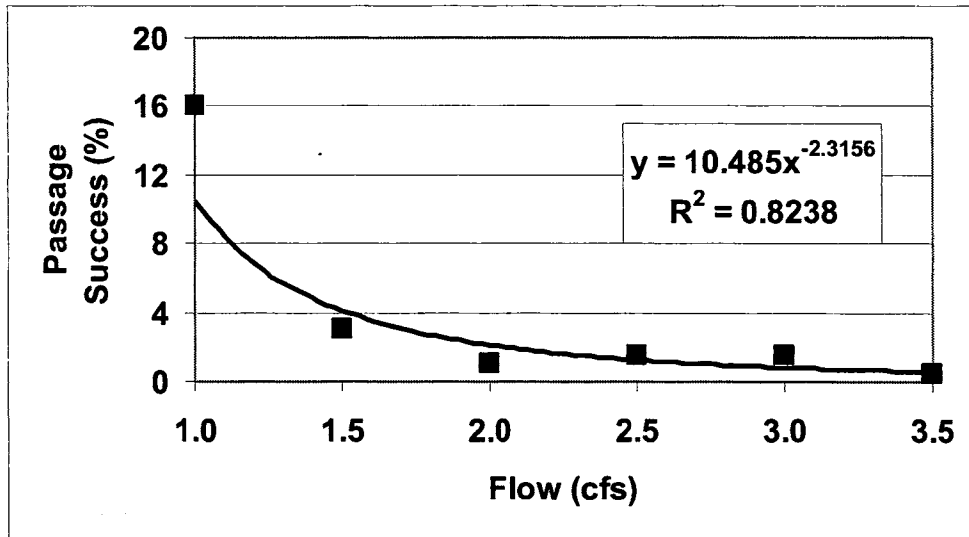
Date	Test ID	Period	Fish Size	N	Duration (h)	Flow (cfs)	Shade
5/27-28	036	Night	Small	200	3	1	No
5/27-28	037	Night	Small	201	3	3	No
5/28-29	038	Night	Small	200	3	2	No
5/28-29	039	Night	Small	200	3	2.5	No
5/29-30	040	Night	Small	200	3	1.5	No
5/29-30	041	Night	Small	200	3	3.5	No

Note: All tests were with a 6-ft round, bare corrugated culvert at 1.14% slope. The distance from invert to net pen floor in TW was 10 in.

**Table 19.** Results from Biological Baseline Characterization in May 27-30, 2003 at the CTB.

Test conditions are presented in Table 18.

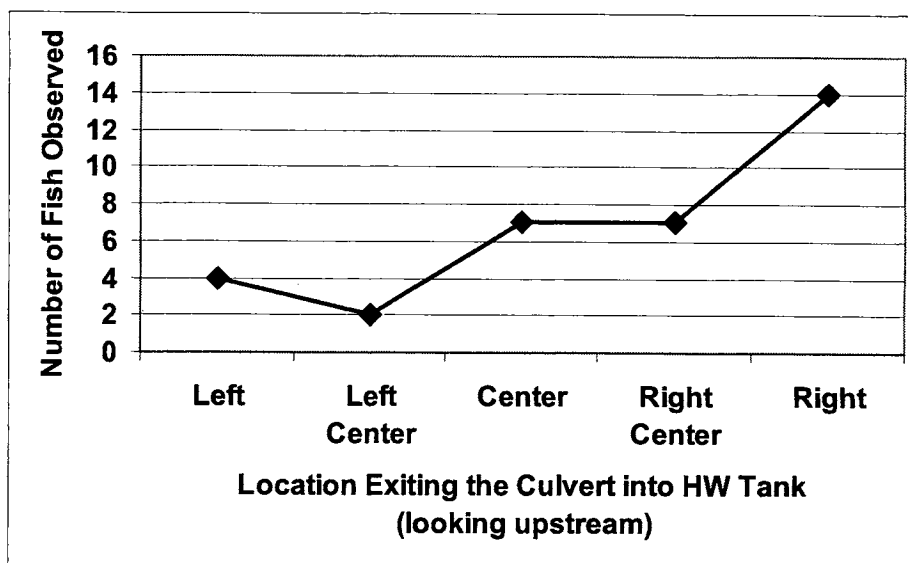
Test Id.	Number of Fish in TW Tank	Number of Fish in Culvert	Number of Fish in HW Tank	Passage Success (%)
036	167	1	32	16.0
037	198	0	3	1.5
038	197	1	2	1.0
039	196	0	3	1.5
040	194	0	6	3.0
041	199	0	1	0.5



**Figure 36.** Relationship between Passage Success (number in HW tank divided by number released) and Culvert Discharge (cfs). All tests were performed during night, lasted for 3 h, and involved the release of 200 test fish. Test conditions are presented in Table 18.

#### 3.2.2.2 Horizontal Distribution of Fish Successfully Passing through the Culvert

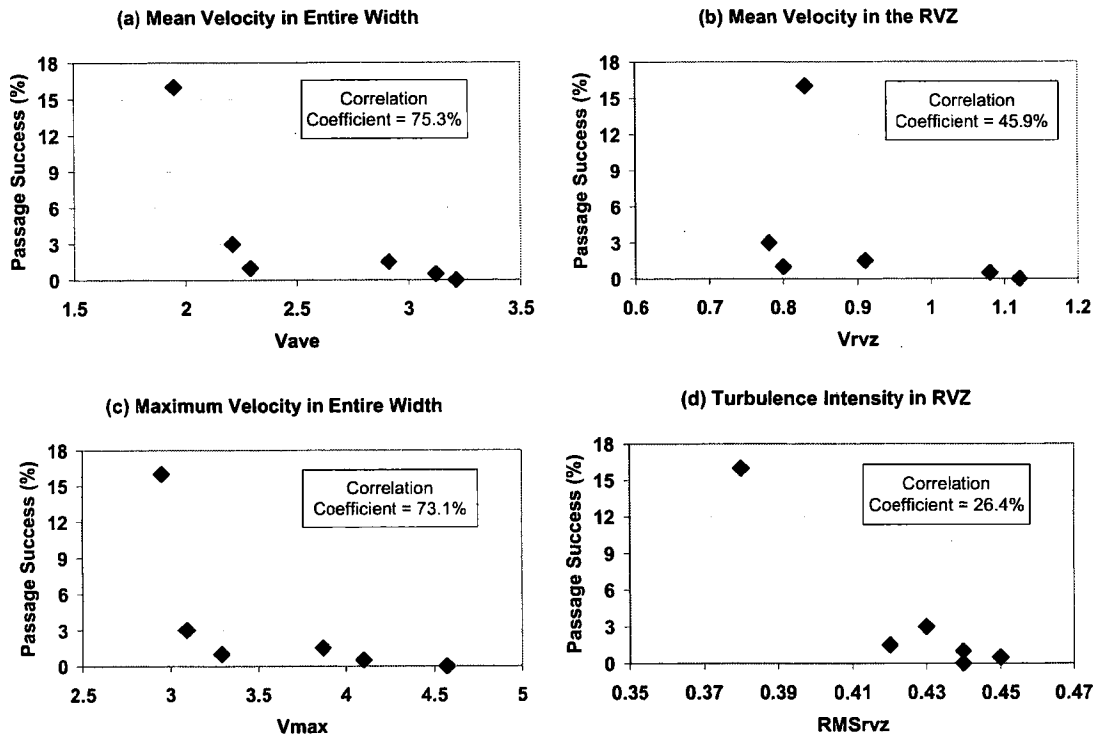
The horizontal location of fish successfully passing through the culvert and into the HW tank was investigated in 2003 using taped video observations from the underwater camera in the HW tank. We divided the culvert flow inlet into five areas: right, right-center, middle, left-center, and left. We chose tests (Tests 035 and 036) with high passage success values. The discharge rates were 1.5 and 1.0 cfs, respectively. Both tests were conducted at night. The data revealed that the horizontal distribution of fish exiting the culvert was skewed to the right (looking upstream) (Figure 37).



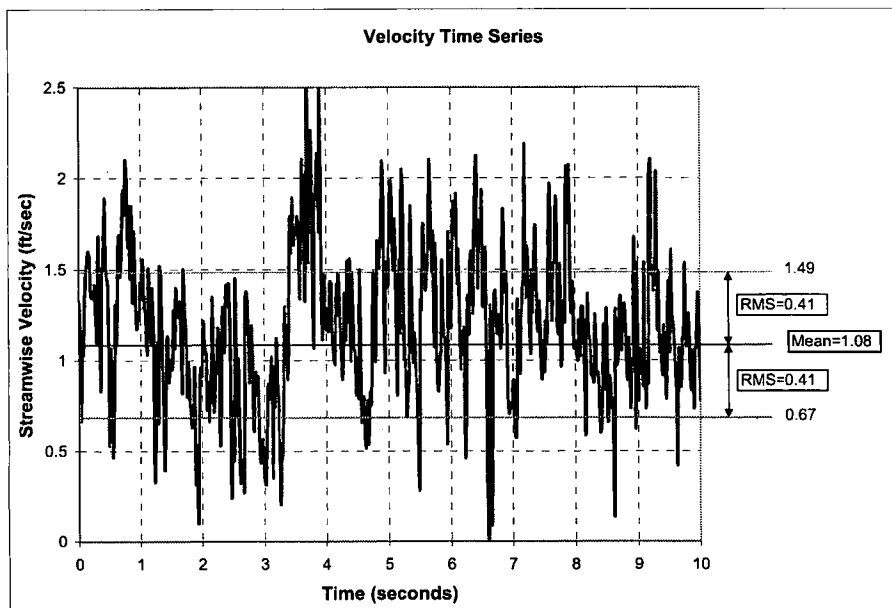
**Figure 37.** Horizontal Distribution of Fish Entering the HW tank after Successful Passage Upstream through the CTB. Data are from the camera in the HW tank viewing the exit from the culvert for Tests 035 and 036 at 1.5 and 1.0 cfs, respectively, during night.

### 3.2.2.3 Relationship between Passage Success and Hydraulics

We explored trends in the relationship between passage success and four hydraulic variables: mean velocity over the entire cross section; mean velocity in the RVZ; maximum velocity over the entire cross section; and mean turbulence intensity in the RVZ. There were six culvert discharges for which hydraulic data were available to compare with the biological data (1, 1.5, 2, 2.5, 3.5, and 4 cfs). Plots of six data points for passage success and each of the four hydraulic variables (Figure 38) reveal that five observations are close to each other (0 through 3% PS) and the sixth is relatively far away (16% PS). These data indicate the general trends of the response - increasing or decreasing for a given independent variable. The correlation coefficients indicate the level of association between passage success (transformed using the arcsine of the square root) and four hydraulic variables; the correlations are positive and range from 26.4% to 75.3% (Figure 38). There is, however, pronounced variability in the hydraulic data. For example, in a 10-sec time-series in the RVZ at 4 cfs, the mean stream-wise velocity was 1 fps and the RMS was 0.41 fps (Figure 39). The ramification of hydraulic variability to the analysis and understanding of conditions for passage success is discussed in the next section.



**Figure 38.** Scatterplot of Passage Success versus Hydraulic Variables. (a) mean velocity over the entire cross section; (b) mean velocity in the RVZ; (c) maximum velocity over the entire cross section; and (d) mean turbulence intensity in the RVZ. The passage-success data are from Tests 036, 040, 038, 039, 041 (200 fish) and 032 (20 fish) for discharges of 1, 1.5, 2, 2.5, 3.5, and 4 cfs, respectively. The arcsine of the square root of the PS proportion was used to compute the correlation coefficient.



**Figure 39.** Example Time-Series of Stream-wise Velocity in the RVZ at 4 cfs in the Middle of the Culvert Test Bed, April and May 2003.



## 4.0 Discussion

WSDOT and its partners have guided the program to achieve a fully functional culvert test bed (CTB) with broad capability to investigate culvert and hydraulic characteristics conducive to the upstream movement of juvenile salmon in culverts. The CTB results to date have illustrated that one fundamental advantage of the CTB is that it allows researchers to integrate detailed hydraulic characterizations with direct observations of fish passage and behavior (Papanicolaou and Talebbeydokhti 2002). The discussion that follows covers CTB research conducted in April/May 2003 and November 2004 and addresses 1) the influence of test conditions on the measurement of juvenile fish passage success in the CTB, 2) the first evaluations of relationship between fish passage success and discharge for the baseline culvert<sup>5</sup>, 3) the influence of hydraulic characteristics on juvenile salmon passage success in the CTB, and 4) considerations for design and protocols in future studies.

### Passage Success and Test Conditions

To develop the testing protocols, we first examined whether volitional upstream movements would occur and then examined the influences of fish size, time of day, light cues, pool depth and fish density (crowding in the tailwater tank) on passage success. Under volitional trials, the juvenile coho salmon did move upstream and the degree of passage success varied significantly with fish size, time of day, and tailwater pool depth.

The tests in April/May 2003 revealed the importance of fish size as an experimental variable. Passage success (PS<sup>6</sup>) values were higher (about 80% at 2 cfs) for the relatively large juvenile coho salmon (mean fork-length 139 mm) than the smaller (mean fork-length 55 mm) test subjects (about 20-25% at 2 cfs). Based on day-time observations in a smaller culvert system of different configuration, Powers et al. (1997) hypothesized that under some circumstances smaller juvenile coho would have higher upstream movement than larger coho. This difference was thought to be because small fish would better utilize the corrugations as resting areas. We observed, however, that at the same flow (2 cfs) the larger fish moved upstream in greater percentages and in shorter times than small fish. Although our preliminary observations do not support the hypothesis that smaller fish would move upstream more readily than larger fish, our observations definitely indicate that fish size must be taken into account in culvert evaluations. We suggest that future work with a fish size intermediate between the large (~160 mm) and small (~55 mm) juvenile coho already tested is warranted and that fish size be taken into account in future studies.

Trials showed that volitional movement upstream was stronger during night than day. Higher passage during night than day was observed for both small and large juvenile coho salmon. The difference was significant ( $P < 0.1$ ) only for the smaller fish. The trials with the larger juveniles

---

<sup>5</sup> The baseline culvert was a 6-ft round, 40-ft long culvert with 3-in by 1-in corrugations, slope of 1.14%, and without any bed configuration.

<sup>6</sup> Passage success is the number of fish in the headwater tank at the end of a 3-h test divided by the number released into the tailwater tank at the beginning of the test. This quantity is multiplied by 100 to express PS as a percentage.

were limited in the number of replicates because of seasonal availability of the larger fish from the hatchery. Increased replication with larger juveniles would have had greater power to detect differences. Experiments with and without shade over the tanks during daytime and white light in the tanks at nighttime indicated that this behavior was related to time of day rather than response to light level. This finding agrees with field observations at culverts by U.S. Forest Service researchers (M. Furniss, USFS, Corvallis, OR, pers. comm. to W. Pearson on June 12, 2003), who have found juvenile coho move primarily at night. Therefore, protocols for future trials with juvenile coho salmon should call for tests at night without additional lighting or shading of the tanks. For other species that may have a diel or crepuscular activity rhythm, pilot trials will be needed to establish the appropriate time of day for testing.

Fish behavior during complete backwatering of the culvert (tailwater raised to be essentially level with headwater tank) indicated that some flow (i.e., velocity, turbulence intensity, etc.) was necessary to elicit upstream movement. Under completely backwatered conditions, more fish were found in the culvert but passage into the headwater tank was similar to standard minimally backwatered tests. The trials for the baseline characterization were conducted with minimal backwatering, as recommended by the Steering Committee.

Some perspective on the CTB results comes from recent field research indicating that upstream movement is common in juvenile coho salmon (Kahler and Quinn 1998; Kahler et al. 2001). The mean percentage of tagged and recovered juveniles (average lengths of 59 to 70 mm) moving in four western Washington streams varied between 28% and 60% (Kahler et al. 2001). Contrary to expectation, upstream rather than downstream movement was predominant. In our tests here with pool depth and density, the passage success (lengths range from 66 to 122 mm and average about 94 mm) with the shallowest pool depth averaged 39% and ranged from 26% to 52%. At the shallow pool depth, the highest passage success was at the lowest density and averaged 36% with a range from 5% to 73%. It appears that the average passage values achieved in the test bed during the pool depth and density trials are in the mid-range of average values for upstream movement in natural streams (i.e., without culverts).

In both the field observations of Kahler et al. (2001) and in the pool depth test here, juvenile movement increased significantly as the depth of the downstream pool decreased. Also, Kahler et al. (2001) found that fish moved from habitats with lower fish densities. Here, we observed that passage success was highest for the lowest density and decreased with increasing density although the differences with density were not statistically significant. Because the habitat units from which coho juveniles moved had low densities, Kahler et al. (2001) suggested that the mechanism behind movement appears not to be displacement by competition for space but rather poor habitat quality. Furthermore, the fish that moved were not smaller and showed higher growth rates than those that did not move, further suggesting that the moving fish are not being displaced by competitive exclusion. The experiments in the test bed with pool depth and density and the findings of Kahler et al. (2001) mutually support each other. The implications of these findings for the test program are that decreasing the depth of the pool in the tailwater tank by raising the false floor and adjusting the density to between 1 and 2 fish/ft<sup>3</sup> will be effective in

increasing the percentage of fish moving upstream in the test bed. The results also suggest that deeper pool depths will probably not be advantageous.

Besides the factors specifically tested in our study, the data from the trials for test conditions and observations from the baseline culvert characterization suggest that other factors related to season and temperature also influence passage success. The influence of fish size is usually taken to be one of swimming performance which increases with fish size. However, fish size is confounded by seasonal changes in both the ambient test conditions (e.g., water temperature) and also perhaps by seasonal differences in the external cues and internal drivers governing upstream movement. Swimming performance for a given fish size is known to vary with water temperature. Griffiths and Alderdice (1972) concluded from their investigation of the influence of temperature on critical swimming speed that the juvenile coho salmon were well adapted to maintain a high level of swimming performance over a broad range of temperatures (especially cooler temperatures). Juvenile coho swimming speed at 2 °C was only half that at 20°C but decreases abruptly above 20 °C to 22 °C (Griffiths and Alderdice 1972). Although the passage success does not appear related to temperature variation (6 °C to 8 °C) in our pool depth studies (Tables 13 and 14), a winter cold snap did appear to influence fish behavior during our tests on leaping ability (C. May, Battelle, pers. comm., January 2005). The results in Table 14 from the pool depth trials do indicate that passage success rates for the same conditions are close on a given day but vary more substantially among days. The reason for this variability among days is not known.

Besides seasonal changes in swimming performance related to size and water temperature, the external cues and internal drivers for upstream movement may differ by season. Kahler et al. (2001) observed in the summer that not only juvenile coho moved upstream more than expected but also a portion of the juvenile fish showed "exploratory" behavior, moving upstream and downstream and then returning to their point of origin. Kahler et al. (2001) suggest that habitat quality is the ultimate driver of summer movement and that both upstream and "exploratory" movement may confer an adaptive advantage when dewatering or other adverse conditions occur during the summer. Fall upstream movement may be related to finding overwintering habitat. The implications of these observations from the CTB and the literature for future CTB studies are discussed below in the subsection on considerations in study design.

#### First Evaluations with Baseline Culvert

In May 2003, tests were performed to evaluate the protocols and characterize the baseline culvert and establish the response relationship between passage success and discharge. The duration for these night tests was standardized at 3 h. Although it is possible that overall passage success rates would have been marginally higher with longer tests, the 3-h duration was chosen because of the trade-off between passage success value and the number of tests that could be performed within a given time period. For the small fish, the passage success decreases as the flow increases from 1 cfs and becomes zero at 4 cfs. There was a clear, exponential trend in the response relationship between passage success and discharge.



To analyze passage success relative to motivation for upstream movement, we counted the number of times fish attempted to enter the culvert from the tailwater tank; however, we could not distinguish individual fish. This meant passage success could not be reported relative to the number of individuals attempting to enter the culvert. Relative passage success of the test population may still prove to be useful, provided the ability to track individual fish is improved. To track individuals, passive integrated transponder tags should be considered, although the steel in the CTB will cause excessive signal interference for the receiving antenna. Innovative ways to deploy the receiving antenna, including specially designed shielding may alleviate this problem. It may also be worthwhile to assess other methods such as Floy-tags or freeze-branding to identify and track individual test fish. The disadvantage of these tagging methods is that all would increase substantially the amount of handling that test fish receive. Allowing for recovery from handling would increase the amount of time that a test fish would need to be held before testing.

#### Hydraulic Conditions and Juvenile Fish Passage Success

The hydraulic characteristics within the culvert relevant to fish passage are different in the inlet, barrel, and outlet zones. The culvert inlet (upstream, headwater end) is characterized by lower average cross-sectional velocities, more uniform cross-sectional velocity distributions, and absence of a Reduced Velocity Zone (RVZ, described further below) compared to the culvert barrel. The lack of a RVZ in this region means there is a short, critical section at the inlet where juvenile salmon would be required to burst through high-velocity, moderate-turbulence water to pass upstream into the headwater tank.

The barrel region comprises the majority of the culvert length where the flow is primarily governed by bed resistance and tailwater elevation. Based on ADV data, the barrel is composed of high-velocity high-turbulence water in the center core of flow, moderate velocity and high turbulence on the left side of the culvert, and low velocity and low turbulence in the upper right corner of the flow (the RVZ). The velocity in the RVZ continues to be below 2 fps even at discharges up to 16 cfs, indicating that if fish can find this area and maintain their position in it, then the likelihood of passage through the barrel region is increased. Since the asymmetry in hydraulic conditions across the culvert is caused by the 5° pitch in the spiraled corrugations, it would be useful for design of culvert retrofits to investigate which commonly manufactured combinations of spiral angle, amplitude, and length maximize the RVZ's cross-sectional area.

The outlet zone at the downstream, tailwater end of the culvert is the first section that fish must pass before entering the barrel section. If backwatered, depth of flow is increased and velocity is reduced; however, at larger discharges (> 2 cfs) the mean velocity can still be higher than the 1-fps prolonged swimming abilities of these fish. Therefore, once a juvenile coho salmon enters the culvert, there is a critical time period for it to find the RVZ on the right side of the culvert. Juveniles moving upstream are more likely to find the RVZ of the CTB if they start on the right side, especially at higher flows. Collectively, these observations indicate where a juvenile salmon enters the culvert at the outlet could influence passage success.

Although this report necessarily treated turbulent fluid flow in a statistical manner, reporting mean velocity values and deviations about the average root-mean-square (RMS), the nature of extreme turbulent events bears further discussion. The time-series of hydraulic data revealed that there were important characteristics other than the mean and RMS parameters. For example, there were numerous moments when the instantaneous velocity was either above or below the RMS range. These bursts of extreme velocity could significantly impact fish, especially relatively small juveniles that can easily be flushed out of the RVZ into the faster core current. Such extreme velocity bursts result from coherent structures of either high velocity fluid from the flow core or low velocity fluid from the bed and can be characterized by their size, rotation, and frequency by looking at the turbulent length scales, vorticity, and spectral distribution of the flow, respectively. Further investigation of these parameters in future studies may help describe the degree and frequency of flow intermittency in the RVZ. The time-series (Figure 39) also illustrates that the nature of the hydraulic environment actually experienced by the fish is both complex and dynamic. The determinant of fish passage success may derive from the way in which the velocity and turbulence interact or in the amount of time that the sum of the velocity and turbulence are below a certain (but as yet unknown) value.

Trials in April/May 2003 enabled us to examine the low-velocity-pathway hypothesis. The hypothesis (Powers et al. 1997; Kane et al. 2000; Pearson et al. 2002) is that juvenile coho salmon will find and use the path in the culvert where they encounter the lowest water velocity and associated turbulence. Hydraulic conditions were uneven across the culvert, apparently because of the spiral corrugation pattern. Using the hydraulics data, we identified the upper, far right side of the culvert (looking upstream) as the reduced velocity zone (RVZ). The horizontal distribution of fish successfully exiting the culvert into the headwater tank was skewed to the right side of the inlet – an observation supporting the low-velocity-pathway hypothesis. In the future, it would be useful to superimpose observed fish tracks on the velocity and turbulence fields to establish an Occupied Zone (OZ). The OZ will most likely correspond to some degree with the RVZ presented here. Given reliable information on the location of the OZ, velocity reduction equations similar to those presented here and in Powers et al. (1997) can be refined and used to estimate appropriate velocity reduction factors. These velocity reduction equations can then be tested against fish passage data.

#### Considerations for Protocols and Study Design in Future CTB Studies

For future studies, we need to consider issues at two levels: 1) protocols and procedures and 2) study design. The test conditions observed to enhance upstream passage in the test bed include:

- trials at night rather than during the day;
- some flow rather than extensive backwatering;
- shallow to moderate but not deep tailwater pool depth;
- fish density between 1 and 2 fish/ft<sup>3</sup>.

The basic procedures for fish handling, release, and retrieval proved effective and without undue stress and with no mortality. Similarly, the basic procedures of the conduct of a trial and the video recording proved effective. It is clear that more cameras to simultaneously record behavior at more locations in the system would be of great benefit. The ADV instrument provided fine scale measurements of velocity and at a speed that enable calculation of turbulence intensity. Some modifications to enhance our ability to measure velocity and turbulence closer to the culvert would be of benefit. The work described in this report suggest that the best test conditions and the procedures in fish handling, hydraulic measurements, and video monitoring are now well established.

The results here also suggest there are several issues that need to be considered in program strategy and specific study designs. First, fish size, water temperature, and season are clearly factors in passage success and need to be incorporated into design of future CTB studies. Water temperatures will need to be monitored, and testing should be avoided at water temperatures above 20 °C and below 4 °C. Fish size and season are correlated so that statistical study designs would consider blocking on season or months and recording fish length as a concomitant variable. An extremely important consideration in study design will be proper control of seasonal factors through close attention to control trials that will need to be interwoven into the trials.

The addition of baffles and changes in inlet or outlet configurations may require re-consideration of the pool depth and backwatering conditions. Whereas the specific values for these conditions that enhance passage success are now established for the baseline culvert, those specific values may not provide the same hydraulic conditions that attract fish and enable passage when baffles or other configurations change the hydraulic patterns. This situation argues for several approaches at the level of study design. First, as tests on different culvert systems and bed configurations are undertaken, some flexibility in adjusting test conditions may be necessary. Second, approaches to statistical design and analysis need to be interwoven with the hydraulic considerations and are best established at the outset of the project. Lastly, a general strategy with both scientific and potential cost benefits is to conduct the biological test first and then the hydraulic characterization. Observations of fish behavior can then be used to "let the fish tell us what is important." The hydraulic characterizations can then be focused on the culvert locations and conditions that appear to be most influential in fish behavior and passage.

## 5.0 Conclusions and Recommendations

The following conclusions are drawn from the work in April/May 2003 and November 2004 at the culvert test bed for upstream passage of juvenile salmon:

1. The CTB facility is completely functional structurally, mechanically, hydraulically, and biologically.
2. The gantry positioning system can locate the ADV to provide detailed water velocity data, from which turbulence intensity can be calculated.
3. The underwater and aerial video cameras in conjunction with infrared lighting at night can provide qualitative data on fish behavior in the tailwater tank, in the culvert barrel, and during entry to the headwater tank, although observing movement of small fish within the culvert is often difficult due to turbulent flow.
4. The procedures for hydraulic characterizations and fish passage tests are ready for use. Volitional trials with a shallow (approximately 9-inch) pool depth and a low-to-moderate fish density (1 to 2 fish/ft<sup>3</sup>) at night without additional lighting are appropriate for future experiments.
5. There are issues at the study design level that need to be addressed in future studies.
  - a. Because passage success varies with fish size and seasonal factors, fish size and seasonal factors will need to be taken into account in the design of future testing programs.
  - b. Specific values for pool depth and backwatering may need to be adjusted if baffles or other configurations change the hydraulic patterns that attract fish and enable passage.
6. For the baseline culvert configuration and the juvenile coho salmon tested in May 2003, preliminary data on the relationship between passage success and flow level showed a decreasing trend in passage success from 1.0 to 3.5 cfs, and that zero passage occurred at 4.0 cfs.
7. Analysis of video observations finds that the fish successfully reaching the upstream end of the culvert exit into the headwater tank predominantly on the right hand side looking upstream. This analysis suggests that the juvenile salmon are using the low velocity - low turbulence zone on the right side of the culvert to accomplish passage.
8. The sum of the behavioral data and observations and the hydraulic measurements is that the fish use the hydraulic features of the system to find and use an appropriate pathway into, through and out of the culvert. There is pronounced variability of hydraulic conditions, e.g., water velocity, turbulence, in space and time. The determinants of fish passage success appear to more to do with the fine scale structure and dynamics of the hydraulics than with the the overall or average hydraulic conditions. This situation reinforces the notion that understanding the interaction of the hydraulic conditions with fish behavior will be key to

understanding the determinants of fish passage success. The culvert test bed and its associated instrumentation are well positioned for such a task.

In closing, recommendations for testing protocols (Table 20) describe the methods to be used consistently from test-to-test in future work. Categories for the protocols include setup of the CTB, experimental design, fish handling, ancillary physical data, and fisheries data collection.

**Table 20.** Recommendations for Evaluation Protocols at the CTB.

Category	Factor	Recommendation	Comment
CTB Setup	Shade over TW and HW tanks	<b>Recommendation</b>	Shade does not significantly affect passage success.
	Distance TW Bottom to Culvert Invert	None	A 9-in distance for 1-4 cfs flows allows juvenile coho salmon to enter the culvert. Tests in 2004 indicate that more fish entered the culvert at shallow than deep depths. This distance may have to be adjusted if baffles change the hydraulic patterns attractive to fish.
	Backwater	Set at 9-10 inches; review for baffled systems	This was the recommendation from the steering committee. Tests conducted in winter 2004/2005 indicate that 0% backwatering may provide even better conditions for promoting fish passage (C. May, Battelle, pers. comm., 2005). Backwatering may have to be adjusted if baffles change the hydraulic patterns attractive to fish.
	Hiding Structures in HW Tank	Backwater minimally into the culvert; review for baffled systems	Not necessary because there are plenty of places for fish to avoid high velocity areas in the HW and to lesser extent in the TW tank. Observed few instances of fallback from the HW tank
Experimental Design	Test period (time of day)	None	Data show most passage for small coho is at dusk/night. Shading trials indicate upstream movement is related to time of day rather than light level.
	Duration (length of a test)	Nighttime	Tested 4 h also, but most activity was usually in first 3 h. Need at least 1 h for fish to acclimate to the TW tank. A 3-h test is reasonable to give fish a thorough opportunity to approach the culvert to move upstream and enables more test to be conducted in a given time period.
	Seasonality	3 h, but reconsider tests all night	There can be seasonal changes in fish behavior that must be accounted for in the experimental design.
	Control Tests	Controls and treatments interwoven across time	Study design will incorporate controls interwoven into tests; Needs statistical design analysis to be done with consideration of specific hydraulics.

Category	Factor	Recommendation	Comment
	Fish Density in TW Tank	Periodically during a series of tests	Although tests with this variable were not conclusive, the fish appeared to be more motivated to move upstream at low to moderate densities, and more inclined to remain in the TW tank at higher densities during the tests conducted in 2004.
	Fish Size	Between 1 and 2 fish/ft <sup>3</sup>	Fish size becomes a confounding factor in the results if it is not accounted for, as passage success could depend on fish size.
	Sampling Unit	Design yearly experimental program appropriately	Cannot distinguish individuals, so this study should employ statistical methods for groups.
Fish Handling	Fish Feeding Regime	All fish in a single test	Fish not fed for 24 h showed more active, exploratory behavior. This does not impact hatchery operations as the test fish are held in a separate net pen in a pond.
	Fish Holding	Feed 24 h before test and then do not feed until after the test	This provides easy access and minimizes handling of the test specimens.
	Acclimation	In net pens but separate from the facility's fish population	Fish "acclimate" after release in the TW tank, so TW holding cages are not needed for acclimation. Allow 3 hours for test duration.
	Counting (Pre-test)	No pre-test holding in the TW tank	Two people to simultaneously count or do consecutive counts prior to releasing fish into TW tank.
	Retrieval	Dual counts	The current retrieval methods are working well, although the lifting mechanism for the end screens should be automated.
Fisheries Data	Fork lengths	Dip nets	Standard practice. Measure TW, culvert, and HW separately.
	Counts (Post-test)	Measure at least 20 fish per test (if available) at end	Cross-check count to number released.
	Video Monitoring	Retrieve fish in TW tank, culvert, and HW tank (in this order)	The time series of observations will include feeding, milling, schooling, milling (without feeding), holding, territorial/aggressive, and/or no fish observed in the field of view.
Physical Data	Staff Gages, Flow, and Manometer	Monitor video in real-time; every 10 min classify behavior	Record these measurements during the test. At least once per day, record the manometer levels when the culvert is dewatered.
	Turbidity	Record TW and HW depths, approximate flow from meter (pre-culvert), and manometer measurements	Use depth scale or secci disc in headwater tank to indicate turbidity
	Water Temperature	Observe at least one time per day	Measure temperature while water is flowing through the CTB. Avoid testing if water temperature is below 4 or above 20 degrees C

Culvert Test Bed – Evaluation Protocols

---

Category	Factor	Recommendation	Comment
	Dissolved oxygen	Record at least one time per test	Record just before each day's test.
	Light Intensity	Measure once each test in HW tank	Record just before each day's test in several standard locations in each end tank, just above the water surface. Also record the ambient (outside with no obstructions) light levels.

---

## 5.0 References

- Barber, M.E., and R.C. Downs. 1996. Investigation of culvert hydraulics related to juvenile fish passage. Research Report for Project T9902, Task 7. Performed for Washington State Transportation Commission by Washington State University.
- Behlke, C.E., D.L. Kane, R.F. McLean, and M.D. Travis. 1991. Fundamentals of culvert design for passage of weak-swimming fish. FHWA-AK-RD-90-10. Fairbanks, AK: Alaska Department of Transportation and Public Facilities. 159 p
- Bowmaker J.K. and Y.W. Kunz. 1987. Ultraviolet receptors, tetrachromatis colour vision and retinal mosaics in the Brown trout (*Salmo trutta*) age-dependant variable. *Vision Res.* vol 27 No 12 pp 2101-2108.
- Ead, S. A., N. Rajaratnam, C. Katopodis, F. Ade. 2000. Turbulent open-channel flow in circular corrugated culverts. *J. Hydr. Eng.*, 126: 750-757.
- Griffiths, J. S. and D. F. Alderice. 1972. Effects of acclimation and acute temperature experience on the swimming speed of juvenile coho salmon. *J. Fish. Res. Bd. Can.* 29: 251-264.
- Kahler, T.H., and T.P. Quinn. 1998. Juvenile and resident salmonid movement and a passage through culverts. Final Research Report for Project T9903, Task 96. Performed for Washington State Transportation Commission by the University of Washington.
- Kahler, T.H.P. Roni, and T.P. Quinn. 2001. Summer movement and growth of juvenile anadromous salmonids in small western Washington stream. *Can. J. Fish. Aquat. Sci.* 58: 1947-1956.
- Kane, D.L., C.E. Belke, R.E. Gieck, and R.F. McLean. 2000. Juvenile Fish Passage Through Culverts in Alaska: A Field Study. Water and Environmental Research Center, University of Alaska, Fairbanks, Alaska. Report Number INE/WERC 00.05.
- Lythgoe, J.N. 1988. Light and vision in the aquatic environment. In *Sensory Biology of Aquatic Animals*. Springer-Verlag, New York.
- Papanicolaou, A. N. and N. Talebbeydokhti. 2002. Discussion of "Turbulent Open-Channel Flow in Circular Corrugated Culverts" by S.A. Ead, N. Rajaratnam, C. Katopodis, and F. Ade. *J. Hydr. Eng.*, 145:547-548.
- Pearson, W.H., M. Richmond, J. Schafer, and K. Bates. 2002. Behavioral Model of Juvenile Salmonid Passage for Assessment of Culvert Designs in an Experimental CTB. Presented at the 132nd American Fisheries Society Annual Meeting, Baltimore, MD. August 2002. Invited Presentation in BioEngineering Symposium IV.
- Powers, P., K. Bates, T. Burns, B. Gowen, and R. Whitney. 1997. Culvert hydraulics related to upstream juvenile salmon passage. Washington Department of Fish and Wildlife report to Washington Department of Transportation. Project No. 982740. Olympia, Washington.

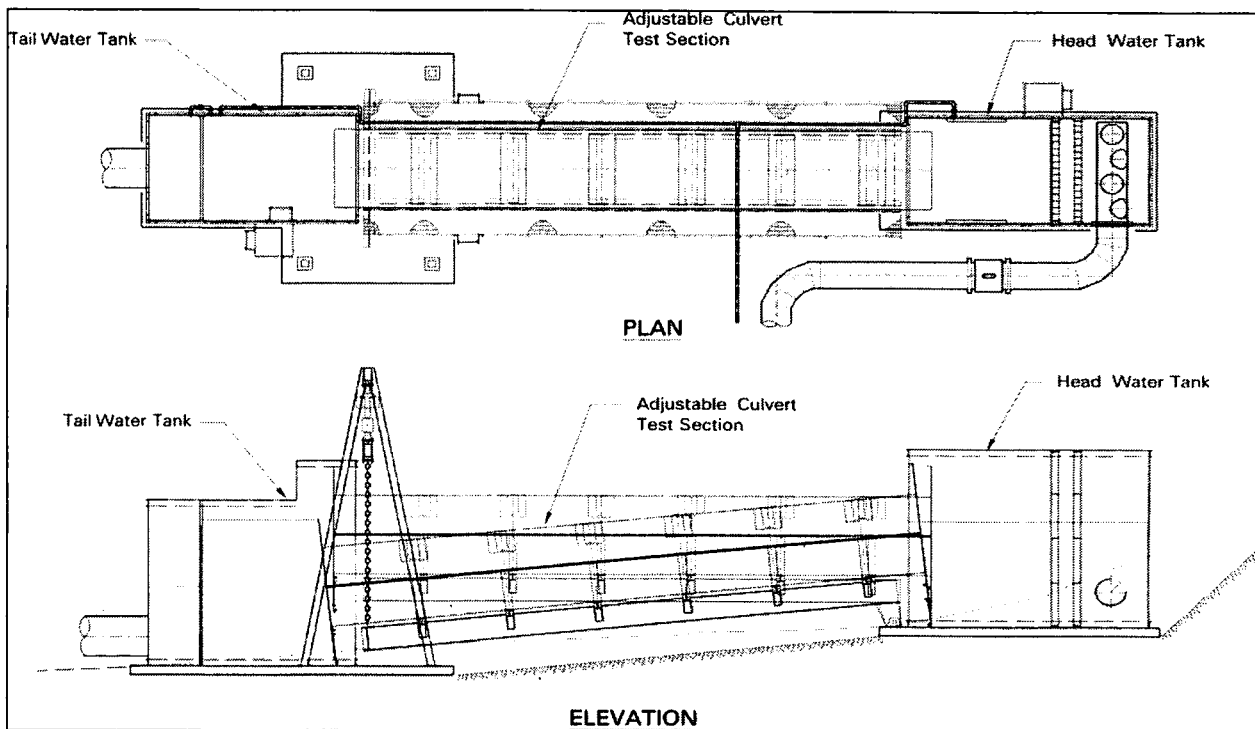


Song, T., and Y.M. Chiew. 2001. Turbulence Measurement in Nonuniform Open-Channel Flow Using Acoustic Doppler Velocimeter (ADV). *J. Engineering Mechanics*. March 2001: 219-231.

## **APPENDIX A: Culvert Test Bed (CTB) Facility Description**

The CTB (Figure A1) is designed to enable the testing of full-scale culvert systems. The intent is to relate quantitative measures of fish behavior and passage success to detailed measures of hydraulic conditions. The general performance criteria of the CTB are:

- Accommodate culverts from 2 to 6 ft in diameter.
- Accommodate round, oval, and box cross sections.
- Accommodate culverts of approximately 40 ft in length.
- Allow bed configuration to be changed.
- Enable the use of gravel as a bed configuration (up to the maximum weight limit for the support structure).
- Allow culverts to be changed.
- Enable the slope of culvert to be changed from near-level to 10%.
- Enable control of water flow rate at a given slope.
- Allow instrument access to measure cross sectional distributions of water depth, mean velocity, and turbulence at several points along the barrel.
- Enable instrument access without compromising the integrity of the wetted portion of the culvert.
- Enable the introduction, acclimation, observation, and recapture of juvenile fish.
- Enable operations with discharges from less than 1 cfs to a maximum of 20 cfs (the maximum flow available to the hatchery).



**Figure A1. Culvert Test Bed** for Evaluation of Passage of Juvenile Salmon through Culverts designed by the Pacific Northwest National Laboratory and Montgomery Watson Harza for the Washington State Department of Transportation.

Discharge will be controlled closely. It will be increased gradually, maintained at a given rate, and then increased or decreased slowly as desired. Once the culvert type, bed configuration, slope, and discharge are set, then water depth and average velocity follow as a consequence of the hydraulics. The Washington Department of Fish and Wildlife (WDFW) has indicated that bed roughness of 0.08 was calculated for gravel bed configurations. Using 0.08 for the Manning’s coefficient in the water supply calculations indicates that a 6-ft culvert tested with a water depth of 1.2 ft would require 19.2 cfs of flow. If the gravel bed configurations have Manning’s coefficients of 0.08 or above, then the CTB and water supply are expected to be sufficient to test such bed configurations up to a 10% slope.

Gravel simulations (mock-ups) will be considered to optimize gravel bed configuration without increasing weight of the system beyond what can be practically managed. If a gravel bed that reaches the spring-line of a 6-ft round culvert needs to be tested, then a support system will be placed inside the culvert so that the depth of gravel in the culvert will not exceed 1 ft. (Note that current practices call for 20% of the culvert diameter to be filled with “spawning” gravel; for a 6-ft culvert, this corresponds to 14.4 in of gravel material).

The primary structures of the CTB include head- and TW tanks, the culvert support system (cradle), the test culvert, and associated piping and valves (Figure A1). The components in the CTB (from upstream to downstream) and their functions include the following:

- *Hatchery Head Tank* supplies the water to both the hatchery and the CTB.

- *Butterfly valve* mounted on the hatchery head tank diverts water flowing into hatchery into the CTB.
- *Large Diameter Pipe* from head tank carries water to the CTB.
- *Flow Meter* in large diameter pipe measures the flow of water entering the CTB.
- *Headwater Tank* in the CTB receives the water, straightens the flow, and passes the water into the culvert. Elements of the HW tank include:
  - *Water Inlet Diffuser Pipe and baffle system* delivers water into HW tank evenly.
  - *Perforated plate and flow straightening vanes* (2 frames) reduce variability in the velocity distribution prior to the water entering the culvert.
  - *Shade and simulated refuge* in HW tank provide conditions that may act as cues to upstream movement by fish.
  - *Removable upstream screen* on the culvert inlet in HW tank is dropped at the end of a trial to capture the fish that had moved upstream into the HW tank.
  - *Headwater Tank Seal Plate* (custom fitted for each culvert type) provides the ability to change the slope of the culvert and then reseal the head water tank.
- *Test Culvert* is the culvert under evaluation and placed into the CTB.
  - *Instrument Mountings* support the instruments and instrument positioning system.
  - *Acoustic Doppler Velocimeter (ADV)* provides fine-scale measurements of the water velocity inside the culvert.
  - *A multi-tube manometer and point Gauge* provide measurements of water surface elevation and depth inside the test culvert.
  - *Ports* in the top of the test culvert provide instrument access at intervals along the length of the test culvert. The ports are covered during trials with fish.
  - *Bed Configurations* (e.g. no baffles, baffles, gravel or gravel simulation) are the physical structures added to the culvert bed or sides to enhance fish passage. Bed configuration will be one of the major items to be evaluated in the program
- *The Cradle* has parallel I-beams to support the test culvert and the walkway.
- *A Frame Hoist* at the downstream end of the culvert enables slope to be adjusted.
- *Blocking* under the cradle bears part of the weight of the test culvert during testing.
- *Tailwater Tank* receives the water flowing out of the test culvert, controls the water level in the downstream end of the culvert, and passes the water to the discharge system.
  - *Tailwater Tank Seal Plate* (custom fitted for each culvert type) provides the ability to change the culvert slope and then seal the tail water tank.

- *Removable downstream screen* in TW tank at culvert outlet is dropped at the end of a trail and separate the fish that moved into the culvert from those remaining in the TW tank.
  - *False bottom* on TW tank enables the water depth in the TW tank to be established at different levels below the downstream end of the culvert.
  - *Fish Screen* in the tail water tank is constructed of perforated plate that passes water downstream but retains the fish in the tail water tank.
  - *Fish Release Cage used for the* the introduction, acclimation, and release of fish during experimental trials.
  - *Tailwater Control Weir* is comprised of stop logs that can be added or removed to control the water level in the TW tank and downstream end of the test culvert.
  - *Gravel Removal Station* on TW tank allows gravel to be removed from the TW tank.
- *Discharge pipes and valves* carry the water from the tail water tank and divert the flow to one hatchery pond, both hatchery ponds, or to the hatchery discharge depending on hatchery requirements.

If high temperatures occur in the summer, the CTB will be shaded. Temperatures will be monitored during all tests. Testing will be suspended if the water temperatures exceed an appropriate threshold (probably 20°C based on the literature). Other components, instruments, equipment, and supplies are listed below.

Other components:

- Fish holding tanks (supplied by Hatchery)
- Portable Office Trailer (rented)
- Power supply (Spider transformer connected to hatchery power supply)
- Conduits from instruments to sensors
- Fish food storage area (supplied by Hatchery)
- Tables for fish handling

Sensors/Instruments:

- Portable turbidity meter and thermometer
- Mini-acoustic doppler velocimeter (ADV) for flow measurements from positions at outlet, inlet and movable locations within the barrel
  - In-line meter for water flow (measuring 3 cfs to 24 cfs with 2% precision and from 1 to 3 cfs with up to 10% precision)
  - Manometer providing water surface elevations at 15 points within the culvert
  - Staff gages to measure depth at inlet and outlet and at least one movable gage within barrel (point gauge)

- Video imagery at outlet, inlet, and one or two movable locations within barrel

Equipment and Supplies:

- Computers
- Data-loggers
- Instrument rack and cabling
- Fish measuring boards
- Fish handling equipment
- Ladders
- Sturdy shoes with nonskid soles