

A Coordination Module for a Crosslinguistic Grammar
Resource

Scott Drellishak

University of Washington

Emily M. Bender

University of Washington

Proceedings of the HPSG05 Conference

Department of Informatics, University of Lisbon

Stefan Müller (Editor)

2005

CSLI Publications

<http://csli-publications.stanford.edu/>

Abstract

The Grammar Matrix is a resource for linguists writing grammars of natural languages; however, up to this point it has not included support for coordination. In this paper, we survey the typological range of coordination phenomena in the world's languages, then detail the support, both syntactic and semantic, for those phenomena in the Grammar Matrix. Furthermore, we describe the concept of a Matrix "module" and our software that enables grammar writers to easily produce an extensible starter grammar.

1 Introduction

The Grammar Matrix (Bender et al., 2002) is an attempt to distill the wisdom of existing broad-coverage grammars and document it in a form that can be used as the basis for new grammars. The main goals of the project are: (i) to develop in detail semantic representations and in particular the syntax-semantics interface, consistent with other work in HPSG; (ii) to represent generalizations across linguistic objects and across languages; and (iii) to allow for very quick start-up as the Matrix is applied to new languages. The current Grammar Matrix release includes types defining the basic feature geometry and technical devices (e.g., for list manipulation), types associated with Minimal Recursion Semantics (see, e.g., (Copestake et al., 2003)), types for lexical and syntactic rules, a hierarchy of lexical types for creating language-specific lexical entries, and links to the LKB grammar development environment (Copestake, 2002). It is, however, completely silent on the topic of coordination.

The next step in Matrix development is the creation of 'modules' to represent analyses of grammatical phenomena which differ from language to language, but nonetheless show recurring patterns (Bender and Flickinger, 2005). These modules are presented to grammar writers through a Web interface that allows them to specify grammatical properties of a language and then download a customized, Matrix-based 'starter-grammar' for that language. In this paper, we propose a design for a module pertaining to coordination. Coordination is an especially important area to cover early on as coordinated phrases have a relatively high text frequency and thus could pose an important impediment to coverage in the development of Matrix-based grammars. In addition, while the world's languages evince a wide variety of coordination strategies, many of the challenges of providing grammatical analyses of coordination constructions are constant across all of the different strategies. Thus a relatively compact statement of the full set of possible modules is possible and the insights gained in existing work on coordination in the English Resource Grammar (version of 10/04, <http://delph-in.net/erg>; (Flickinger, 2000)) can be reasonably directly applied to other languages.

[†]We would like to thank Dan Flickinger, whose analysis of coordination in the English Resource Grammar has served as the basis of this work, as well as the reviewers for and audience at HPSG 2005 for helpful discussion. In addition, we would like to thank the students in Linguistics 567, Spring 2005, for testing the coordination module in their grammars.

In this paper, we restrict our attention to *and* coordination but consider how coordination works for different phrase types as well as both 2-way and n-way coordination.¹ §2 provides a typological sketch of coordination strategies found in the world’s languages. §3 motivates design decisions we have taken in this analysis. §4 describes in detail our implementation of coordination. §5 presents a sample analysis of a coordination strategy in Ono, a Trans-New Guinea language. Finally, in §7 we discuss further extensions to the grammatical analysis and issues of the user interface.

2 Typology of Coordination

The term “coordination” (or sometimes “conjunction”) covers a wide range of phenomena across the world’s languages. In this initial version of the coordination module, we focus on syntactic structures in which two or more elements of the same (or similar) grammatical category are combined into a single larger element of the same category.

Even if we focus on this simplified subset of coordination, we find a wide variety of coordination strategies across the world’s languages and across the phrase types within those languages. These strategies can be classified along several dimensions; among these are the kind of marking, the pattern of marking, the position of the mark, and the phrase types coordinated by the strategy. The coordination module in the Matrix must accommodate all meaningful combinations of these dimensions. This is accomplished by the software underlying the Web interface, which customizes a starter grammar according to the answers provided by the grammar writer.²

2.1 Kinds of Marking

The kind of marking most familiar to speakers of Indo-European languages is lexical marking, in which one or more lexical items (also known as *conjunctions*) mark the connection between the coordinands. The English *and* is an example of a lexically-marked coordination strategy:

(1) Lions *and* tigers *and* bears

¹We leave for future work issues such as non-constituent coordination or the interaction of syntactic and coordination (e.g., Beavers and Sag (2004); Dalrymple and Kaplan (2000)).

²It is worth noting that there exists in many languages an additional type of coordination strategy that is not covered by the Matrix coordination module. Following Stassen (2000), the world’s languages can be classified as either AND- or WITH-languages. AND-languages are those with the familiar syntactic coordination discussed here. WITH-languages, on the other hand, mark coordination asymmetrically: one coordinand is unmarked, while the others are marked by a particle or morpheme meaning “with”. In this type of coordination strategy, sometimes referred to as *comitative coordination*, the syntax (and possibly the semantics) is that of an adjunct. This strategy is quite common among the world’s languages, but we take it to be a separate phenomenon, and it is not covered by the Matrix coordination module.

In some languages, coordination is unmarked, being accomplished by the simple juxtaposition of the coordinands with no additional material, as in Abelam, a Sepik-Ramu language spoken in New Guinea:

- (2) wany balə wany aɬ wanyɬ.bəŋ
that dog that pig fight
'that dog and that pig fight' (Laylock, 1965, 56)

Note that the noun phrases glossed as "that dog" and "that pig" are simply juxtaposed, but they receive a coordinated reading.

In still other strategies, coordination is marked morphologically, usually by an affix on one of the words in a coordinand, as in this example from Kanuri, a Nilo-Saharan language:

- (3) kə̀rə̀zə̀ málə̀mrò wálwònò.
studied.CONJ malam became
'He studied and became a malam.' (Hutchison, 1981, 322)

In this example, the two verb phrases are coordinated by marking the earlier verb with the "conjunctive form".

Consider also this example from Telugu, a Dravidian language:

- (4) kamalaa wimalaa poDugu.
Kamala Vimala tall
'Kamala and Vimala are tall.' (Krishnamurti and Gwynn, 1985, 325)

The two names being coordinated are marked simply by the lengthening of their final vowels. This kind of marking could possibly be analyzed as phonological rather than morphological. Languages with juxtaposition strategies may also be utilizing phonological marking, because such strategies are often marked by a distinctive "comma intonation" on each coordinand. For the purposes of this Matrix module, however, this kind of marking does not need separate treatment: strategies like the Telugu one above can simply be treated like other spelling-changing morphological rules, and intonation does not generally appear in orthographies (although punctuation may serve as a proxy for intonation).

2.2 Patterns of Marking

There are several different patterns of marking attested in the world's languages. In *monosyndeton* strategies, one mark serves to coordinate any number of coordinands:

- (5) A B conj C
'A, B, and C'

In *asyndeton* strategies, no coordinands are marked. This is equivalent to juxtaposition:

- (6) A B C
‘A, B, and C’

In *polysyndeton* strategies, more than one coordinand is marked. For the purposes of the coordination module, it turned out to be important to distinguish between the case where all but one coordinand is marked, and where all coordinands are marked. We therefore reserve the term *polysyndeton* for the former ($n - 1$ marks for n coordinands, (7)) and refer to the latter (8) as *omnisyndeton*.

- (7) A conj B conj C
‘A, B, and C’

- (8) conj A conj B conj C
‘A, B, and C’

For each pattern of marking above (except for *asyndeton*), there are two possible positions of the mark if it is a lexical item or prefix or suffix: before the coordinand, or after the coordinand. The English *and* (along with its cognates in most other Indo-European languages) is an example of a mark that comes before the coordinand, because it precedes the final one. The Latin suffix *-que*, on the other hand, is an example of a mark that follows the final coordinand:

- (9) Senatus Populusque Romanus
Senate people.AND Roman
‘The Senate and people of Rome.’

2.3 Different Phrase Types

Finally, coordination strategies vary as to the types of phrases they cover. In the Indo-European languages, a single coordination strategy often serves to coordinate all types of constituent phrases. It is quite common, however, for coordination strategies to only cover a subset of the types of phrases in the language. For example, in Fijian the coordination of noun phrases is marked by the conjunction *kei*, while that of sentences, verb phrases, adjectival phrases, and prepositional phrases is marked by the conjunction *ka* (Payne, 1985, 5).³

2.4 Typology and the Web Interface

To summarize, then, we analyze coordination strategies in the world’s languages as varying along four dimensions:

³See Drellishak (2004) for a survey of variation with respect to phrase types covered in coordination strategies in the world’s languages.

1. Kind of Marking: lexical, morphological, none.
2. Pattern of Marking: a-, mono-, poly-, or omnisyndeton.
3. Position of Marking: before or after the coordinand.
4. Phrase types covered: NP, NOM, VP, AP, etc.

This analysis of the typological facts drove the design of the Web interface. The grammar-writer is presented with a brief explanation of the kinds of strategies that are covered, and then, for each coordination strategy, answers a series of questions by filling in form fields:

1. What phrase types are covered by the strategy?
2. Which of the marking patterns does it use?
3. Is it marked by a word or an affix?
4. What is the orthography of that word or affix?
5. Does the mark come before or after the coordinand?

When the form is submitted, software running on the web server checks to ensure that the answers are consistent (e.g. if a lexical strategy is specified, the orthography must be supplied), and then produces a starter grammar ready to be downloaded and used. It is worth noting that the set of grammars describable by answering these questions is somewhat smaller than the set of grammars the coordination module can support. For instance, coordination could be marked by an infix, reduplication, or other complex morphological process, or the marking pattern could vary somewhat from the patterns described above. §5 will describe how a coordination strategy with such a variant marking pattern can nonetheless be implemented on the basis of our analysis.

3 Design Decisions

3.1 Category-specific Rules

It may seem desirable at first to have a single rule that covers the coordination of all phrase types. However, experience with detailed work on English (as represented by the English Resource Grammar) suggests that this is not practical, given our formalism and current assumptions about feature geometry. The core generalization⁴ is that phrases of the same category can be coordinated to make a larger phrase of that category. Thus a common first-pass attempt at modeling coordination involves a rule that identifies HEAD and VAL values across the coordinands and the mother (see e.g., Sag et al. (2003)). However, there are features which have been placed inside HEAD for independent reasons which need not be identified across coordinands, such as AUX:

⁴This generalization is subject to several well known exceptions, which tend to have low text frequency.

(10) Kim slept and will keep on sleeping.

Further, there are differences in the semantic effects of coordination for individuals and events. In particular, we follow the ERG in introducing a new index for the coordinated phrase. Since all nominal indices must be bound by quantifiers in well-formed representations (Copestake et al., 2003), NP coordination rules must introduce a quantifier as well. Similarly, the NOM coordination rules must introduce quantifiers for each coordinand.

Finally, there are idiosyncrasies to coordination in certain phrase types. A prime example here is the agreement features on coordinated NPs in English. For NPs coordinated with *and*, at least, the number of the conjoined phrase is always plural, and the person is the lesser of the person values of other coordinands (first person and second person give first person, etc.). In the context of our cross-linguistic analysis, we also find languages where the coordination strategy is different for different phrase types.

In light of these facts, the analysis is considerably simplified by positing separate rules for the coordination of different phrase types. These rules stipulate matching HEAD values, rather than identifying them. The rules are, of course, arranged into a hierarchy in which supertypes capture generalizations across all of the different coordination constructions.

3.2 Binary branching structure

Whether coordination involves binary branching or flat structure is a matter of much theoretical debate (see e.g., Abeillé (2003)). Rather than review those arguments here, we present two engineering considerations which support a binary branching analysis.

First, while the LKB allows rules with any given number of daughters, it does not permit rules with an underspecified number of daughters. This means that a rule like (11a) would have to be approximated via some number of rules with a specific arity (11b):

- (11) a. $XP \rightarrow XP+ conj XP$
b. $XP \rightarrow XP conj XP$
 $XP \rightarrow XP XP conj XP$
 $XP \rightarrow XP XP XP conj XP$
 ...

The relevant rule from such a set would assign the following flat structure to three coordinated phrases:

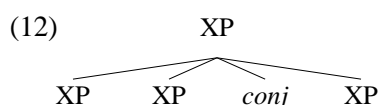

With binary branching, in contrast, three rules produce an unlimited number of coordinands:

- (13) XP → XP XP-co (top coord rule)
 XP-co → XP XP-co (mid coord rule)
 XP-co → *conj* XP (bottom coord rule)

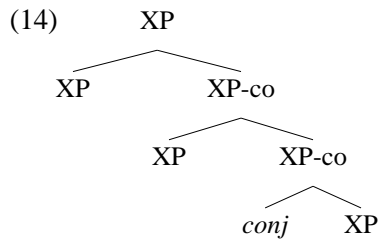

Second, there is the issue of “promotion” of agreement features in coordinated NPs (and potentially other phrase types). In French, for example, the gender value of a coordinated NP is masculine iff at least one of the coordinands is. In order to state this constraint in our system, we will need separate rule subtypes, one of which posits [GEND *masc*] on the mother and on one daughter, leaving the other daughter unspecified, and another that requires [GEND *fem*] on the mother and both daughters.⁵ In either system, this means increasing the number of rules, but the binary branching system starts out with fewer rules (and in fact, only the top and mid coordination rules need to be duplicated, not the bottom coordination rule). The flat structure system, on the other hand, potentially has a very large number of rules to start with. When we also consider promotion of person values, the number of rules involved gets even larger, and the gain from the binary branching system becomes even clearer.

4 Implementation

The implementation of coordination in the Matrix is substantially based on the coordination implementation of the English Resource Grammar (ERG) (Flickinger, 2000). In particular, the Matrix uses a similar set of unary and binary rules and semantic relations to model the structure of *n*-way coordination. The Matrix coordination rules are simplified with respect to the ERG rules, because the Matrix does not support all the details of English coordination, as well as generalized, because the Matrix needs to cover coordination strategies quite unlike those of English.

4.1 Coordination Structures

The analysis introduced above will assign the following structure to three XPs coordinated with an English-like lexical strategy:

⁵(2000) set-based system for succinctly handling such facts is not currently available in the LKB.

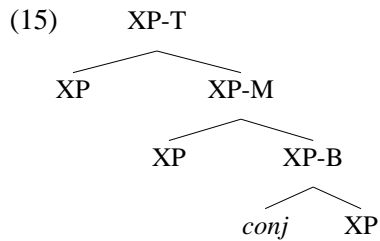

This is accomplished using three rules: a binary “top” rule, a binary “mid” rule, and a “bottom” rule. Other kinds of coordination strategies will be assigned similar structures, with the variation between strategies captured by variations in the mid and bottom rules: asyndeton and polysyndeton strategies lack a mid rule entirely, bottom rules can be either unary or binary depending on whether the strategy is marked lexically or morphologically, and omnisyndeton strategies require special treatment (see §4.1.3 below). Each coordination structure will consist of a single top phrase dominating the whole structure, one or more right-branching mid phrases, and a single bottom phrase dominating the rightmost coordinand (and its lexical or morphological marking, if any). Note that mid rules will iterate to deal with more coordinands, producing a single large coordination structure; for example, the coordination of four elements by an English-like lexical strategy will be assigned the following phrase structure:

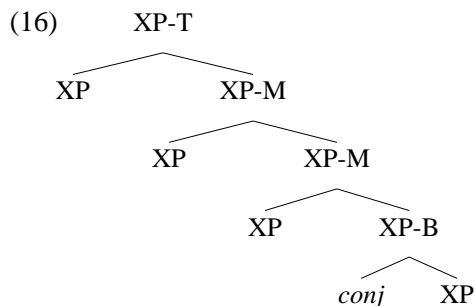

The top phrase is a full-fledged XP and can occur anywhere in a sentence a non-coordinated XP can occur, but the mid and bottom phrases should not combine with other constituents via the ordinary rules. Similarly, other kinds of phrases should not appear inside of a coordination structure. To enforce this, we define a new boolean feature **COORD** on *local-min* (the value of **LOCAL**). Constraints on types high in the hierarchy ensure that all lexical items and ordinary phrase structure and lexical rules are [**COORD** –]. The various patterns of marking can be defined by the **COORD** values of phrases and their left and right daughters (as discussed below).

Below are the portions of the feature structures that define the syntax of the Matrix’s basic coordination structures:

$$(17) \left[\begin{array}{l} \textit{coord-phrase} \\ \text{SYNSEM} \mid \text{LOCAL} \mid \text{CAT} \left[\begin{array}{l} \text{HEAD} \left[\text{MOD} \boxed{1} \right] \\ \text{VAL} \quad \boxed{2} \end{array} \right] \\ \text{LCOORD-DTR} \boxed{3} \left[\begin{array}{l} \textit{sign} \\ \text{SYNSEM} \mid \text{LOCAL} \mid \text{CAT} \left[\begin{array}{l} \text{HEAD} \left[\text{MOD} \boxed{1} \right] \\ \text{VAL} \quad \boxed{2} \end{array} \right] \end{array} \right] \\ \text{RCOORD-DTR} \boxed{4} \left[\begin{array}{l} \textit{sign} \\ \text{SYNSEM} \mid \text{LOCAL} \mid \text{CAT} \left[\begin{array}{l} \text{HEAD} \left[\text{MOD} \boxed{1} \right] \\ \text{VAL} \quad \boxed{2} \end{array} \right] \end{array} \right] \\ \text{ARGS} \left\langle \boxed{3}, \boxed{4} \right\rangle \end{array} \right]$$

$$(18) \left[\begin{array}{l} \textit{top-coord-rule} \\ \text{SYNSEM} \mid \text{LOCAL} \mid \text{COORD} \quad - \end{array} \right]$$

$$(19) \left[\begin{array}{l} \textit{mid-coord-rule} \\ \text{SYNSEM} \mid \text{LOCAL} \mid \text{COORD} \quad + \end{array} \right]$$

The inheritance relationships for these types are shown in the following tree:

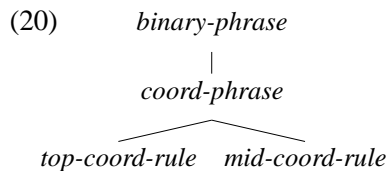

Note that all of these rules derive from *binary-phrase* (rather than *binary-headed-phrase*) and are therefore headless. This approach was chosen in order to avoid making an unwarranted typological generalization about the headedness of coordination structures.⁶ It also prevents some obvious problems with agreement. Consider a language in which the coordination of two singular NPs triggers plural agreement. If AGR is a HEAD feature, then the HEAD value of the whole phrase cannot be identified with either coordinand. Note also that our approach does not identify the HEAD values of the two coordinands, for similar reasons. Consider again the number of coordinated NPs: it is perfectly grammatical to coordinate singular and plural noun phrases, even though the two have conflicting AGR values. Furthermore, although the Matrix Web interface only outputs strategies that cover single phrase types, this is not necessary in principle, because many languages allow coordination of non-identical categories. For all of these reasons, it would be

⁶See Borsley (2005) for a discussion of the problems with headed analyses.

inappropriate to identify any of the HEAD values involved in coordination structures. Instead, the phrase-specific rules derived from the above abstract rules must stipulate the HEAD types.

The remainder of section 4.1 discusses how we capture the variation in marking strategies (monosyndeton, polysyndeton, asyndeton, and omnisyndeton).

4.1.1 Monosyndeton

For monosyndeton strategies, coordination structures are defined by the following rules (in which the value of COORD on a phrase is shown after it in parentheses):

- (21) XP-T (-) → XP (-) XP (+)
 XP-M (+) → XP (-) XP (+)
 XP-B (+) → *conj* XP (-)

These rules license the following phrase structure:

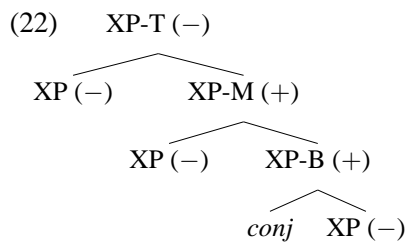

4.1.2 Poly- and Asyndeton

The rules that define poly- and asyndeton strategies, perhaps surprisingly, are very similar to each other; the only difference between the two strategies is that an asyndeton strategy will have a unary bottom rule instead of one that introduces a conjunction or other coordination mark. In both cases, there is no mid rule. The rules for lexically marked polysyndeton are as follows:

- (23) XP-T (-) → XP (-) XP (+)
 XP-B (+) → *conj* XP (-)

The rules for asyndeton (note the lack of a conjunction in the bottom rule) are as follows:

- (24) XP-T (-) → XP (-) XP (+)
 XP-B (+) → XP (-)

For a lexically marked polysyndeton strategy, the rules in (23) license the following phrase structure. Note how the lack of a mid rule forces the alternation of the top and bottom rules, which in turn requires the appearance of the correct number of conjunctions:

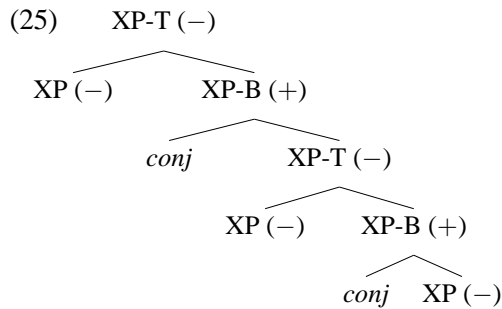

Similarly, the rules in (24) license the following structure for an asyndeton strategy:

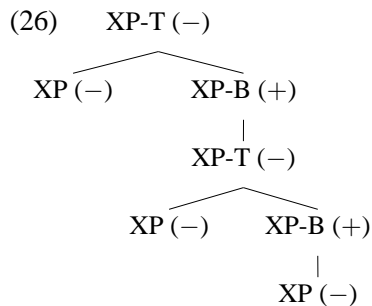

4.1.3 Omnisyndeton

Omnisyndeton strategies, in which coordination of n elements requires n marks, call for a somewhat different approach. The Matrix defines the coordination structures for omnisyndeton using the following rules:

- (27) XP-T (-) → XP-B (+) XP (+)
 XP-M (+) → XP-B (+) XP (+)
 XP-B (+) → conj XP (-)

Note that, unlike the previous rule paradigms, for omnisyndeton the top and mid rules explicitly require a bottom phrase as their left daughter. This ensures that every coordinand is marked:

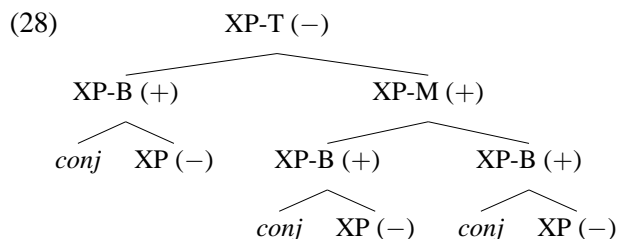

As we will see below, the semantics of omnisyndeton require an additional distinction to be made between the rightmost bottom phrase and all the others.

4.2 Coordination Semantics

The Matrix's semantic representation for the coordination of an unbounded number of elements is handled in the same way as the syntax: one or more binary relations are arranged in a right-branching tree that simulates an n -way flat structure. To this end, we define a relation that coordinates two arguments:

(29) $\left[\begin{array}{ll} \text{LBL} & \textit{handle} \\ \text{C-ARG} & \textit{coord-index} \\ \text{L-HNDL} & \textit{handle} \\ \text{L-INDEX} & \textit{individual} \\ \text{R-HNDL} & \textit{handle} \\ \text{R-INDEX} & \textit{individual} \end{array} \right]$

In addition to dealing with any marking, it is the role of the bottom phrase to contribute a coordination relation associated with its marking conjunction or morpheme, such as *_and_coord_rel*). We define a new feature COORD-REL, also on *local-min*, that is used to store the *coordination-relation* contributed by a phrase. This relation's left and right arguments are left unspecified by the bottom rule; instead, they are identified in the rule licensing the bottom phrase's parent (either a mid or a top rule).

In addition to the coordination relation supplied by the bottom phrase, each mid phrase contributes an *implicit-coord-rel* that serves to link more-than-two-way coordination. For example, three-way coordination in a strategy including a mid phrase would be represented as follows (with the identification of the L-INDEX and R-INDEX represented by branches in the tree):

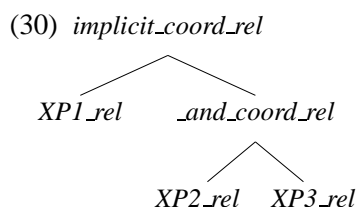

Below are the portions of the feature structures that define the semantic representations of the Matrix's basic coordination structures:⁷

⁷It is worth pointing out that these feature structures only refer to indices and not to handles. We believe NP coordination should not constrain the handles of the coordinands because the handle of an NP is the handle of a quantifier, and in MRS nothing should constrain the handle of a quantifier. Therefore, these generic rules, from which all phrase types' coordination strategies derive, do not constrain the handles. The handles are identified in non-NP phrase types by deriving from a type called *event-coord-phrase* (not shown here). Thanks to Ivan Sag for pointing out this missing detail.

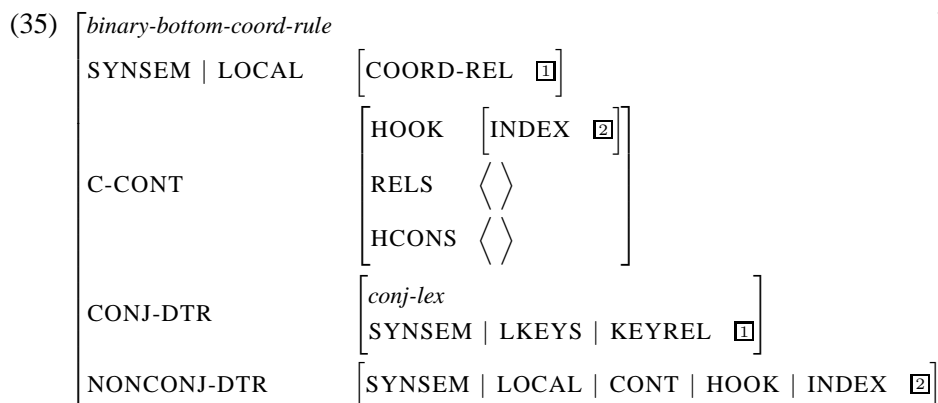
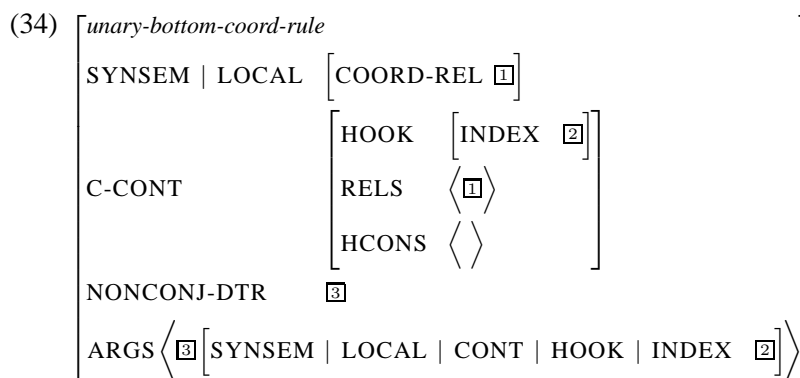
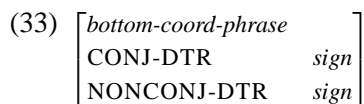
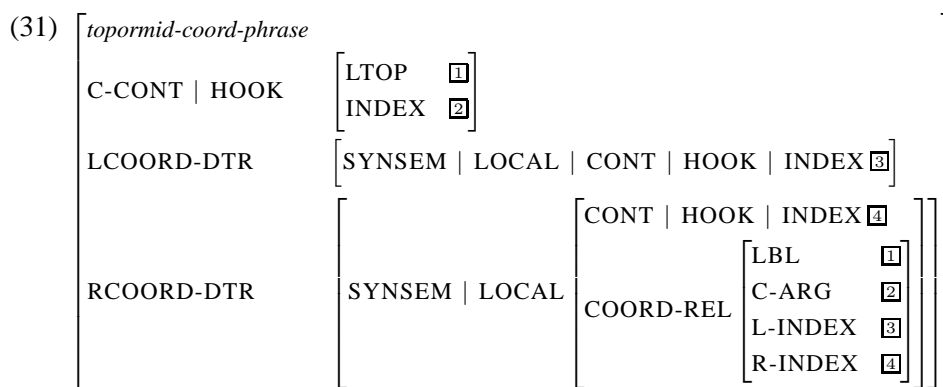

The inheritance relationships among these types and the types in (17) through (19) above are shown in the following trees:

(36)

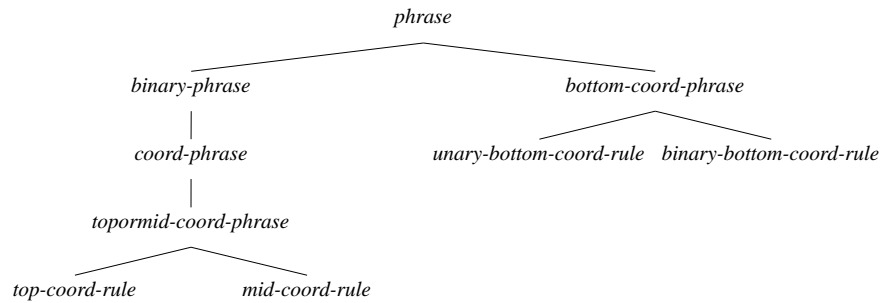

The semantic representations produced by these types are consistent across different marking types and strategies. For example, the coordination of three verb phrases using any strategy produces a representation something like the following:

(37)

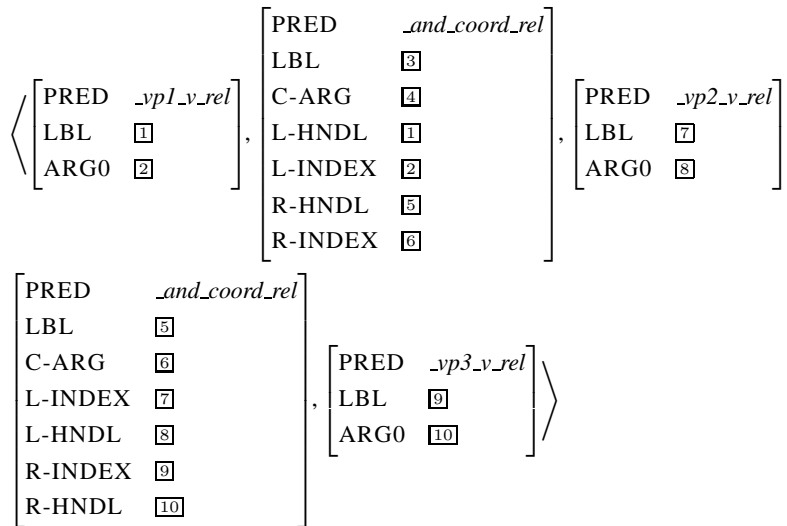

The similarity of the semantic representation for various coordination strategies enables, among other things, generation with multiple coordination strategies. Consider a language with two strategies for VPs. If we parse a sentence with coordinated VPs and then generate from the semantic representation produced, we will get (at least) two sentences: one in which the coordination is marked with the first strategy, and one in which it is marked with the second.

Omnisynдетon strategies present a problem for this approach: they have the same number of bottom phrases as they have coordinands; therefore, there are one too many *coordination-relations*. This means that omnisynдетon must be handled slightly differently. The rule for the rightmost bottom phrase requires a conjunction or morpheme with the same spelling as the conjunction or morpheme that marks the strategy, but which is semantically empty. We also define a new kind of bottom phrase, which we call a “left” phrase, with the usual semantics, and make the omnisynдетon top and mid rules require a left phrase as their left daughter:

- (38) XP-T (-) → XP-L (-) XP (+)
 XP-M (+) → XP-L (-) XP (+)
 XP-B (+) → conj XP (-)

The result is a semantic structure for an omnisyndeton coordination strategy that is exactly the same as for the other strategies, as in (30) above. The phrase structure assigned to a three-coordinand omnisyndeton construction is as follows:

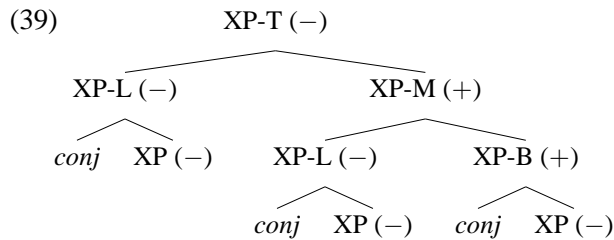

4.3 Summary of Implementation

The coordination module in the Grammar Matrix contains two sets of rules that support coordination: syntactic rules and semantic rules. The syntactic rules include rule paradigms for each of the marking strategies. These paradigms derive from 17–19 above, and include:

- *monopoly-top-coord-rule* and *monopoly-mid-coord-rule*, which license monosyndeton (with optional polysyndeton) marking.
- *apoly-top-coord-rule*, which licenses asyndeton and polysyndeton marking.
- *omni-top-coord-rule* and *omni-mid-coord-rule*, which license omnisyndeton marking.
- *unary-bottom-coord-rule* and *binary-bottom-coord-rule*, which license bottom phrases.

The semantic coordination rules include rule paradigms for various phrase types; for example, *basic-np-top-coord-rule*, *basic-np-mid-coord-rule*, and *np-bottom-coord-rule*, which identify the appropriate COORD-REL arguments for noun phrases.

The grammar writer, either by hand or using the Web interface, can derive coordination strategies from these rules. Each rule in the paradigm for a particular language-specific strategy will derive from two Matrix rules: one syntactic and one semantic. As an illustration, the following are the (very brief) type definitions output by the Web interface in order to license an English-like lexical monosyndeton NP coordination strategy:⁸

⁸The feature COORD-STRAT, which has not been discussed, serves to prevent the interference of rule paradigms for strategies that cover the same phrase type. For example, if the target language has two NP strategies, many ambiguous parses would be licensed if mid phrases from the first strategy could be the RCOORD-DTR of top phrases from the second strategy.

```

(40) np1-top-coord-rule :=
      basic-np-top-coord-rule &
      monopoly-top-coord-rule &
      [ SYNSEM.LOCAL.COORD-STRAT "1" ].
np1-mid-coord-rule :=
      basic-np-mid-coord-rule &
      monopoly-mid-coord-rule &
      [ SYNSEM.LOCAL.COORD-STRAT "1" ].
np1-bottom-coord-rule :=
      conj-first-bottom-coord-rule &
      np-bottom-coord-phrase &
      [ SYNSEM.LOCAL.COORD-STRAT "1" ].

```

5 Sample Analysis

In this section, we provide a sketch of an analysis of coordination of verb phrases and noun phrases in Ono, a Trans-New Guinea language. As described by Phinmore (1988), Ono noun phrases are coordinated with monosyndetic *so*, as in (41), while verb phrases are coordinated by inflecting non-final verbs into a “medial” form, as in (42).

(41) koya so kezong-no numa len-gi
rain and clouds-ERG way block-3sDS
‘Rain and clouds block the way...’ (Phinmore, 1988, 100)

(42) mat-ine gelig-e taun-go ari more zoma ka-ki so
village-his leave-MED town-to go-MED then sickness see-him-3sDS and
ea seu-ke
there die-fp.-3s
‘He left his village, went to town, and got sick and died there.’ (Phinmore, 1988, 109)

We handle the NP coordination strategy with three rules: *np-top-coord-rule*, *np-mid-coord-rule*, and *np-bottom-coord-rule*. These inherit from both the Matrix’s generic NP coordination rules and from the rules for monosyndetic, lexically-marked coordination. This is almost enough to produce a working coordination strategy; all that remains is to specify in the derived NP bottom rule that the lexical item *so* is required as the left daughter.

The VP rules are more interesting. There will be two derived rules: *vp-top-coord-rule* and *vp-bottom-coord-rule*. They derive from the generic VP rules provided by the Matrix and from the rules for asyndeton (hence the lack of a mid rule). The VP bottom rule is unary, because in this strategy the last coordinand is unmarked. The top rule, on the other hand, must specify somehow that its left daughter is in the medial form. If we assume a boolean head feature MEDIAL

whose value is + for medial verbs and verb phrases, then all the top rule needs to specify is that its left daughter's head is [MEDIAL +].

So, although the Ono VP coordination strategy is marked by a pattern that may seem not, at first glance, to be covered by the Matrix's rule paradigms, the two VP coordination rules are in fact quite straightforward. They simply derive from the appropriate Matrix generic rules, with the following additional features specified:

(43)	$vp\text{-top-coord-rule}$ SYNSEM LOCAL CAT HEAD LCOORD-DTR SYNSEM LOCAL CAT HEAD RCOORD-DTR SYNSEM LOCAL CAT HEAD	<table style="border-collapse: collapse; width: 100%;"> <tr><td style="border-right: 1px solid black; padding: 2px;"><i>verb</i></td><td style="padding: 2px;"></td></tr> <tr><td style="border-right: 1px solid black; padding: 2px;">VFORM</td><td style="padding: 2px;">[1]</td></tr> <tr><td style="border-right: 1px solid black; padding: 2px;">TAM</td><td style="padding: 2px;">[2]</td></tr> <tr><td colspan="2" style="border-top: 1px solid black; border-bottom: 1px solid black;"></td></tr> <tr><td style="border-right: 1px solid black; padding: 2px;"><i>verb</i></td><td style="padding: 2px;"></td></tr> <tr><td style="border-right: 1px solid black; padding: 2px;">VFORM</td><td style="padding: 2px;">[1]</td></tr> <tr><td style="border-right: 1px solid black; padding: 2px;">TAM</td><td style="padding: 2px;">[2]</td></tr> <tr><td style="border-right: 1px solid black; padding: 2px;">MEDIAL</td><td style="padding: 2px;">+</td></tr> <tr><td colspan="2" style="border-top: 1px solid black; border-bottom: 1px solid black;"></td></tr> <tr><td style="border-right: 1px solid black; padding: 2px;"><i>verb</i></td><td style="padding: 2px;"></td></tr> <tr><td style="border-right: 1px solid black; padding: 2px;">VFORM</td><td style="padding: 2px;">[1]</td></tr> <tr><td style="border-right: 1px solid black; padding: 2px;">TAM</td><td style="padding: 2px;">[2]</td></tr> <tr><td style="border-right: 1px solid black; padding: 2px;">MEDIAL</td><td style="padding: 2px;">-</td></tr> </table>	<i>verb</i>		VFORM	[1]	TAM	[2]			<i>verb</i>		VFORM	[1]	TAM	[2]	MEDIAL	+			<i>verb</i>		VFORM	[1]	TAM	[2]	MEDIAL	-
<i>verb</i>																												
VFORM	[1]																											
TAM	[2]																											
<i>verb</i>																												
VFORM	[1]																											
TAM	[2]																											
MEDIAL	+																											
<i>verb</i>																												
VFORM	[1]																											
TAM	[2]																											
MEDIAL	-																											

This rule identifies several features of the coordinated VPs beyond what the generic rules specify. This right-branching structure of coordination is enforced as usual by the COORD feature, so it is not necessary to specify MEDIAL on the mother node, which can only serve as the RCOORD-DTR of any further higher coordination. The structure assigned the coordination of three VPs, the first two of which are in medial form (and labeled VP-medial), is shown in (44).

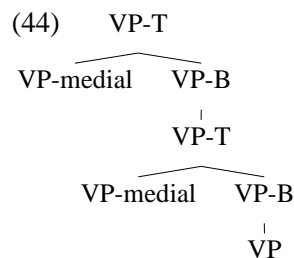

6 Predictions and Theoretical Implications

This analysis of coordination makes typological predictions. First, because our coordination structures are right-branching, they would not naturally accommodate a language that marks coordination only on the first coordinand: “*conj* A B C”. However, that pattern is apparently unattested (Stassen, 2000). Thus, the theory of

coordination we have implemented matches the typological distribution of coordination strategies.⁹

There is something odd about our coordination structures: we use the feature COORD to separate the syntactic space into two domains: the simulated N-way coordination structures, and everything else (regular syntax). This is a powerful tool, but it means that some nodes in the tree do not necessarily correspond to constituents. We also have rules in the omnisyndeton paradigm that require a particular *type* of daughter phrase, not just a phrase with a particular HEAD type. This not the way things are usually done in HPSG (it is certainly not “head-driven”), but we only do it inside of our coordination structures, and it has the not inconsiderable virtue of producing the right result.

Our analysis also makes some predictions about ambiguity. Monosyndeton languages seem to *always* optionally allow polysyndeton—although the semantics will presumably differ—and our analysis does likewise. In fact, it posits multiple structures for mono-, poly-, and asyndeton strategies:

(45) $[[A \text{ conj } B] \text{ conj } C]$ vs. $[A \text{ conj } [B \text{ conj } C]]$

It does not do so, however, for omnisyndeton strategies: the second reading above would require a different surface string:

(46) $[\text{conj } [\text{conj } A \text{ conj } B] \text{ conj } C]$

It would be interesting to know if this prediction is borne out in natural languages with the omnisyndeton strategy: does this sort of “conjunction stacking” actually occur?

Finally, the Matrix’s coordination analysis makes what might be an incorrect prediction about ambiguity. Recall that we treat right-branching coordination structures as unmarked, but left-branching grouping as exceptional. Surely, however, there are three possible readings:

(47) $[A \text{ and } B \text{ and } C]$ (flat)
 $[[A \text{ and } B] \text{ and } C]$ (left-branching)
 $[A \text{ and } [B \text{ and } C]]$ (right-branching)

If all three of these readings really are available, and in particular if the flat and right-branching readings can be distinguished, then we are failing to capture all the possible semantic representations.

⁹Note that if this pattern *were* attested, we could address it by having both left- and right-branching versions of the rules. That is, another theory is possible, but the current one seems to fit the facts.

7 Conclusion and Outlook

We have presented an overview of an initial version of a coordination module for the Grammar Matrix. We believe that it is suited to providing syntactically and semantically valid analyses of the diverse coordination strategies in the world's languages. Furthermore, the factored representation given to the underlying types used to create language-specific coordination systems provides a means of formalizing generalizations across languages.

The next steps for this project include testing the coverage of the module by deploying them in implemented grammars for a diverse range of languages, refining and extending the user interface presented to the grammar-writer, and expanding the coverage to include other types of coordination. In particular, we note that there are a wide variety of coordination phenomena not currently covered, including but not limited to: adversative (“but”) coordination, which seems limited to two coordinands; correlative conjunctions (e.g. “both...and”); and complex phenomena such as gapping and non-constituent coordination.

Those interested in seeing this project in action are invited to visit our web site, where they can generate a simple but functional grammar for their language of study. The URL for the site is:

<http://depts.washington.edu/uwcl/HPSG2005/modules.html>

References

- Abeillé, Anne. 2003. A Lexicalist and Construction-Base Approach to Coordinations. In Stefan Müller (ed.), *Proceedings of HPSG03*, Stanford: CSLI.
- Beavers, John and Sag, Ivan A. 2004. Ellipsis and Apparent Non-Constituent Coordination. In Stefan Müller (ed.), *Proceedings of HPSG04*, pages 48–69, Stanford: CSLI.
- Bender, Emily M. and Flickinger, Dan. 2005. Rapid Prototyping of Scalable Grammars: Towards Modularity in Extensions to a Language-Independent Core. In *Proceedings of the 2nd International Joint Conference on Natural Language Processing IJCNLP-05*, Jeju Island, Korea.
- Bender, Emily M., Flickinger, Dan and Oepen, Stephan. 2002. The Grammar Matrix. *Proceedings of COLING 2002 Workshop on Grammar Engineering and Evaluation*.
- Borsley, Robert D. 2005. Against ConjP. *Lingua* 115, 461–482.
- Copestake, Ann. 2002. *Implementing Typed Feature Structure Grammars*. Stanford: CSLI.

- Copestake, Ann, Flickinger, Daniel P. and Sag, Carl Pollard Ivan A. 2003. Minimal Recursion Semantics. An Introduction.
- Dalrymple, Mary and Kaplan, Ronald M. 2000. Feature Indeterminacy and Feature Resolution. *Language* 76, 759–798.
- Drellishak, Scott. 2004. *A Survey of Coordination Strategies in the World's Languages*. Masters Thesis, University of Washington.
- Flickinger, Dan. 2000. On Building a More Efficient Grammar by Exploiting Types. *NLE* 6 (1), 15–28.
- Hutchison, John P. 1981. *A reference grammar of the Kanuri language*. Madison, WI: University of Wisconsin - Madison.
- Krishnamurti, BH. and Gwynn, J. P. L. 1985. *A grammar of modern Telugu*. Delhi: Oxford University Press.
- Laylock, D. C. 1965. *The Ndu language family (Sepik district, New Guinea)*. Linguistic Circle of Canberra, Series C, No 1, Canberra: The Australian National Library.
- Payne, John R. 1985. Complex Phrases and Complex Sentences. In Timothy Shopen (ed.), *Language Typology and Syntactic Description Vol. 2: Complex Constructions*, pages 3–41, Cambridge: Cambridge University Press.
- Phinnemore, Penny. 1988. Coordination in Ono. *Language and Linguistics in Melanesia* 19, 97–123.
- Sag, Ivan A., Wasow, Thomas and Bender, Emily M. 2003. *Syntactic Theory: A Formal Introduction*. Stanford: CSLI.
- Stassen, Leon. 2000. AND-languages and WITH-languages. *Linguistic Typology* 4, 1–54.