

**Possessor Raising in Nuu-chah-nulth\***

Christine Ravinski  
University of British Columbia

**Issue:**

Nuu-chah-nulth (hereafter denoted as NCN) exhibits a construction whereby the possessive clitic *-uk/-(/)ak /-at* appears on the predicate rather than in its base position on the head noun of a possessed phrase.

**Questions:**

- How do the structures of the two grammatical possessive constructions differ, and what evidence shows this?
- What can these teach us about the wider grammatical structure of NCN?

**I. Overview of possessive constructions****A. Non-raised possession**

1. One way NCN marks possession is through a clitic attached to the possessum: *-uk* or *-(/ )ak* for alienable<sup>1</sup> possession or

\* I am sincerely grateful to my language consultants Mary Jane Dick, Katherine Fraser, Archie Thompson, Josephine Thompson, Barbara Touchie, Sarah Webster and Barney Williams Jr. for sharing their language and their insights with me. Thanks also to H. Davis, F. Lee, L. Matthewson, R. Wojdak, F. Woo, M. Wiltschko, J. Muehlbauer and O. Steriopo for helpful discussion and advice. Fieldwork was funded by a Jacobs Research Fund grant, a UBC Hampton Fund Research Grant awarded to Dr. Henry Davis, and SSHRCC grant #410-2002-1715 awarded to Dr. Lisa Matthewson. Any errors are my own.

<sup>1</sup> Phonological and morphological evidence shows that the possessive and durative morphemes are different although often homophonous. Compare:

a. witq- <b>ak</b>	b. witq- <b>uk</b> -/iS
ugly- <b>DUR</b>	ugly- <b>POSS</b> -3.IND
<i>It is ugly/poor work</i>	<i>His/hers is ugly/poor work.</i>

*-at* for inalienable<sup>2</sup>, together with person and number agreement morphology.

Possessive agreement paradigm:

	Singular	Plural
1st	-uk/-/at -qs	-uk/-/at -qin
2nd	-uk/-/at -/itk	-uk/-/at -/itqsuu
3rd	-uk/-/at -O	-uk/-/at -O-(/i(/al)) <sup>3</sup>

2. NCN attaches this clitic plus agreement to the first word of the possessive phrase, in which normal word order is possessum (PSM) followed by possessor (PSR). (Rose, Davidson, Braithwaite) This is the only possible word order where ambiguity is possible.

(1) a. niCa - nose      b. niCa/atqs - my nose<sup>4</sup>  
 niCa                      niCa -/at -qs  
 nose                      nose - **INAL** -**I.S**

(2) a. house      b. Rachel's house      c. Rachel's new house  
 maHTii      maHTii-ak-/i R.      CuSuk-uk-/i maHTii R.  
 house      house-**POSS**-DET R.      new-**POSS**-DET house R.

(3) a. Sam's friend/relative  
 /uSHYums uk-/i Sam  
 friend - **POSS**-DET Sam

b. Sam's friend/relative's father  
 NuWiiqs ak-/i /uSHYums uk-/i Sam  
 father- **POSS**-DET friend-**POSS**-DET Sam

<sup>2</sup> Note that *-at* is also the passive marker. Whether these are homophones or a single morpheme remains unresolved as of this writing.

<sup>3</sup> Agreement on 3Plural is optional. (R. Wojdak, pc)

<sup>4</sup> See key to glosses page 8.

- c. *Sam's father's friend/relative*  
/uSHYims -**uk**-/i NuWiiqs -**ak**-/i Sam  
friend-**POSS**-DET father- **POSS**-DET Sam

- (4) a. *Adam threw Henry's rock.*  
Tijizit/iS Adam **Muks/i/ak/i Henry**  
Tijiz - mit - /iS Adam Muks/i -/ak -/i Henry  
throw-PST-3.IND Adam rock/stone-POSS-DET Henry

- b. # Tijizit/iS Adam **Henry Muks/i/ak/i**

-MJD: "I'd know what you were trying to say, but if you have *Henry* before *Muks/i/ak/i*, it sounds like he [Adam] threw Henry."

Where the PSR and PSM are clear, phrasal word order is flexible.

- (5) a. *John's teacher is a canoe-maker.*  
japacma?ukviS **tijjaak/i John**  
japac-ma?uk-/iS tijja-/ak-/i John  
canoe-maker.of-3.IND teacher-POSS-DET John

- b. japacma?ukviS **John tijjaak/i**

3. Possessed phrases can be in unrestricted sentence position.

- (6) a. *Mary sees Sue's father.*  
naatsijiz/iS Mary NuWiiqsak/i Sue  
naatsi-ciz -/iS Mary NuWiiqsu-/ak-/i Sue  
see-PERF-3.IND Mary father-POSS-DET Sue

- b. *Sue's father sees Mary.*  
naatsijiz/iS NuWiiqsak/i Sue Mary  
naatsi-ciz -/iS NuWiiqsu-/ak-/i Sue Mary  
see-PERF-3.IND father-POSS-DET Sue Mary

## B. Possessor Raising

1. Sentences or phrases in which a possessum has the thematic role of the subject can alternatively be expressed with the possessive marker on the predicate<sup>5</sup> instead of or in addition to on the possessum.

- (7) a. *John's canoe holds lots.*  
/ayaqs/is Japacuk/i John  
/aya-qs -/is Japac-**uk** -/i John  
lots -in.a.vessel-3.IND canoe-**POSS**-DET John

- b. *John's canoe holds lots.*  
/ayaqsuk/is John Japac  
/aya-qs -**uk** -/is John Japac  
lots -in.a.vessel-**POSS**-3.IND John canoe

2. The subject inflection of the predicate, evident in the person/number of the final mood marker, matches the possessor in cases of possessor raising (PR). This agreement normally corresponds to the sentence's subject. (Wojdak 2004, Davidson 2002, Rose 1981)

Possessive marked on the argument:

- (8) a. *My cat is lazy.*  
wiwiiS/aqz/is piiSpi**Sukqs**  
R -wiiS/aqz-**iS** piiSpiS-**uk** -**qs**  
redup-lazy-**3.IND** cat -**POSS-1.S**

<sup>5</sup> In cases where the main predicate is not the host of the particular clausal subject-agreement enclitics, the possessive marker may also appear on e.g. relative pronoun.

Possessive marked on the predicate:

- b. *My cat is lazy.*  
 wiwiiS/aqzuksiS piiSpiS  
 R -wiiS/aqz-uk -siS piiSpiS  
 redup-lazy-POSS -IS.IND cat
3. Raising is only possible where the possessive marker originates from a subject, including the derived subject of a passivized sentence.
- (9) a. *Adam threw his (own) rock.*  
 Tij iz/iS Adam Muks/i/ak/i  
 Tij iz-/iS Adam Muks/i-/ak-/i  
 throw-3.IND Adam rock-POSS-DET
- b. *Adam threw his (own) rock.*  
 # Tij izuk/iS Muks/i Adam<sup>6</sup>  
 Tij iz-uk-/iS Muks/i Adam  
 throw-POSS-3.IND rock Adam
4. Raised and non-raised possessive constructions are thematic paraphrases; in meaning they are more or less synonymous.<sup>7</sup> (Speakers differ on the allowability of possessor doubling, below. This may show a difference that is as yet undescribed.)
- (10) a. *The doctor's car is ugly.*  
 witq/iS huupukvasuk/i /uStaquy/i  
 witq -/iS huupukvas-uk -/i /uStaquy-/i  
 ugly-3.IND car -POSS-DET doctor -DET
- b. *The doctor's car is ugly.*  
 witquk/iS huupukvas /uStaquy/i  
 witq-uk -/iS huupukvas /uStaquy-/i  
 ugly-POSS-3.IND car doctor -DET
5. The possessor and possessum are no longer a unified constituent where raising has occurred.
- The PSM and PSR form constituents in the non-raised construction. In 11a-b, their order can be reversed, but another element cannot be inserted between them. (11c)
- (11) a. *Florence's teacher wants to make a canoe.*  
 /ukviil maHsa/iS Florence tijaak/i Japac  
 /ukviil -maHsa-/iS Florence tija-ak-/i Japac  
 make-want-3.IND Florence teacher-POSS-DET canoe
- b. /ukviil -maHsa-/iS tija-ak-/i Florence Japac
- c. \*/# /ukviil maHsa/iS Florence Japac tijaak/i  
 /ukviil -maHsa-/iS Florence Japac tija -ak -/i  
 make -want -3.IND Florence canoe teacher-POSS-DET
- In contrast, the same test shows that in the raised construction the PSM and PRS are no longer constituents. (11d)
- d. *Florence's teacher wants to make a canoe (for Florence).*  
 /ukviil maHsatuk/iS Florence Japac tijaak/i  
 /ukviil -maHsa-/at-uk-/iS Florence Japac tija-/ak-/i  
 make-want-PASS-POSS-3.IND Florence canoe teacher-POSS-DET

<sup>6</sup> This means something like "His rock threw Adam."

<sup>7</sup> cf Nakayama 2001

## 6. PR is clause-bound.

Possessor raising cannot occur across clause boundaries. In the example below, when the possessive marker *-uk* is moved past the relative to the main predicate, possession can only be interpreted in the main clause.

(12) a. *I hit the man who lost my axe.*

ZikSizitsiS jakup yaqitii pawal sap hiishiisaJakukqs  
 Zik-Siz -mit -siS jakup yaq-it -ii pawal -sap  
 hit-PERF-PST-1S.IND man who-PST-3.I.REL loose-CAUS

hiishiisaJak-uk -qs  
 axe -POSS-1S

b. *I hit the man who lost my axe.*

*/I hit the man by whom my axe was lost.*  
 ZikSizitsiS jakup ya?atukvitiis pawal saPat hiishiisaJak  
 Zik-Siz -mit -siS jakup yaq-/at -uk -mit-iis  
 hit-PERF-PST-1S.IND man who-PASS-POSS-PST-1S.I.REL

pawal -saP-/at hiishiisaJak  
 loose-CAUS-PASS axe

c. *My husband*<sup>8</sup> *hit [him] who lost an axe.*<sup>9</sup>

*/\*I hit the man who lost my axe.*

ZikSizukvitsiS jakup yaqitii pawal sap hiishiisaJak  
 Zik-Siz -uk -mit-siS jakup yaq-mit-ii  
 hit-PERF-POSS-PST-1S.IND man who-PST-3.I.REL

pawal -sap hiishiisaJak  
 loose -CAUS axe

## 7. Possessive doubling: While the possessive marker can appear in 2 possible locations, it may also appear in both together. Acceptability judgments on this vary.

(13) *The doctor's car is ugly.* (Compare (10) above)

witquk/iS huupuKvasuk/i /uStaquy/i  
 witq-uk -/iS huupukvas-uk -/i\_\_/uStaquy-/i  
 ugly-POSS-3.S.IND car -POSS-DET doctor-DET

(14) *Ken's canoe got broken (by him/her).*

Kvayap/atuk/iS Japacuk/i Ken  
 Kva -yaap- /at -uk -/iS japac-uk-/i Ken  
 to break-caus-PASS -POSS -3S.IND canoe-POSS-DET Ken

(15) *John's arm was broken by a bear.*

KvayaaPatukvit/iS John /a/aapyuml /at/i (/uHat) jims  
 Kva -yaap -/at -uk -mit-/iS John  
 broken-CAUS-PASS-POSS-PST-3.S.IND John

/a/aapyuml -/at-/i (/uHat) jims  
 arm/shoulder-POSS-DET (by) bear

<sup>8</sup> A possessive on *man* or *woman* indicates one's *husband* or *wife*.

<sup>9</sup> Mary Jane Dick tells me that this is more clearly expressed thus:

ZikSizukvitsiS jakup /uHtaa yaqitii pawal sap hiishiisaJak  
 Zik-Siz-uk-mit-siS jakup /uH-taa yaq-it-ii pawal -sap hiishiisaJak  
 hit-PERF-POSS-PST-3.IND man one-to.smone who-PST-3.I.REL loose-CAUS axe

- In contrast with previous observations (Lee 2003, Braithwaite 2003, Davidson 2002), this construction is not restricted to constructions without an agent.

agentive subject:

- (16) a. *My teacher bit a dog* (\* *A teacher bit my dog*)<sup>10</sup>  
 Maj izukvitsiS tiija ?iniiz  
 Maj iz-uk -mit -siS tiija ?iniiz  
 bite -POSS-PST-1S.IND teacher dog

transitive predicate:

- (17) a. *My dog found a ball.*<sup>11</sup>  
 /uyu/aal /iS hupkuml ?iniizukqs  
 /u-yu/aal -/iS hupkuml ?iniiz-uk-qs  
 O- find -3.IND ball dog-POSS-1.S

- b. *My dog found a ball.*  
 /u-yu/aal -uk-siS hupkuml ?iniiz  
 /u-yu/aal -uk -siS hupkuml ?iniiz  
 O- find -POSS-1S.IND ball dog

## II. PR and the notion of SUBJECT in NCN

Definition of cross-linguistic possessor raising:

A construction where the possessor with a “semantic or argument-structure dependency on an element within a “lower” constituent is [being] structurally realized in a “higher” syntactic unit”, such that the possessor and possessum are contained within separate

<sup>10</sup> Because my speakers tend to adhere to an animacy hierarchy, the more expected sentence “My dog bit a teacher” becomes passivized. (See Kim 2000 for more discussion of the role of animacy in passives.)

<sup>11</sup> Thanks to Rachel Wojdak for these data.

constituents and the possessor becomes a core grammatical relation of the verb. (Payne and Barshi 1999)

- The description in I. shows that the PSR and PSM become separate constituents

Question:

Does the raised possessor constitute a core grammatical relation of the verb? (Is a raised possessor a “subject”?)

### A. Structural assumptions about subject-hood.

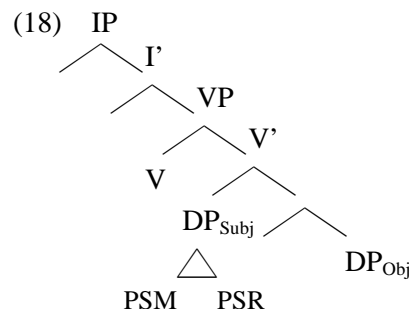

Under the view represented in the structure in 18, properties of the traditional grammatical function “subject” split between an “underlying” thematic subject and a “surface” subject which controls morphological changes such as case and agreement. The two are often related through syntactic movement.

Question:

Are the properties of a raised possessor those of an underlying or a surface subject?

**B. Tests for underlying vs surface subjects:**

1. Subject agreement: The final clitic on the predicate agrees in person and number with the subject. (Rose 1981, Davidson 2002, Wojdak 2004)
2. Subject control: Complex predicate environments exhibit subject control of PRO in the absence of the morpheme *-ap* (Wojdak, pc)

- I propose that these tests show both underlying and surface subject positions remain active in PR constructions

1. Subject agreement

(19) *I am singing.* (adapted from Davidson p. 101)  
 nunuukvazaH  
 nunuuk-/az-maH  
 sing-TEMP-1S.IND

- In view that agreement is positionally determined, this is indicative of a surface subject

2. Subject control

Recent data collected by R. Wojdak shows that the subject has control over PRO in the environment of a complex predicate, except where the causative marker *-ap* is present, in which case a disjoint reference reading results.

- Consider the following:

**No additional inflection on predicate: Subject control reading**

(20) a. *Florence's teacher wants [PRO] to make a canoe.*  
 /ukviil maHsa/iS tijjaak/i Florence Japac  
 /ukviil -maHsa-/iS tijja -ak -/i Florence Japac  
 make -want -3.IND teacher-POSS-DET Florence canoe

**Causative only added to the predicate: disjoint reading**

- b. Florence wants her teacher to make a canoe.  
 /ukviil maHsap/iS Florence tijjaak/i Japac  
 /ukviil -maHsa-/ap-/iS Florence tijja -ak -/i Japac  
 make -want -CAUS-3.IND Florence teacher-POSS-DET canoe

**Poss only on the predicate: Subject control reading**

- c. *Florence's teacher wants to make a canoe.*  
 /ukviil maHsak/iS Florence tijjaak/i Japac  
 /ukviil -maHsa-ak -/iS Florence tijja -ak -/i Japac  
 make -want -POSS-3.IND Florence teacher-POSS-DET canoe

The above data show that subject control is from the underlying position.

- If *Florence* were the underlying subject of 20c, we predict the sentence would be infelicitous, b/c it would say Florence is making the canoe.
- The underlying subject (the PSM teacher) is still syntactically active, and is not an adjunct.

**III. The emerging structure**

Underlying form:

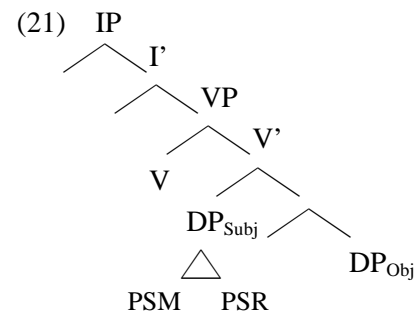

Predicate-initial verb-raising:

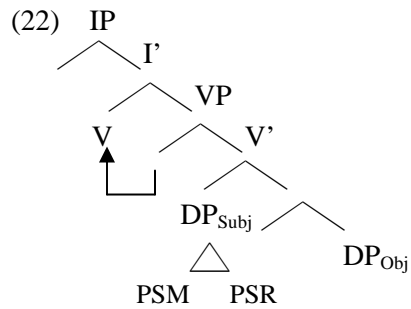

-uk (representing the possessive morpheme) raises above the VP. I assume a copy-raising analysis by way of explaining the possessive doubling observed earlier.

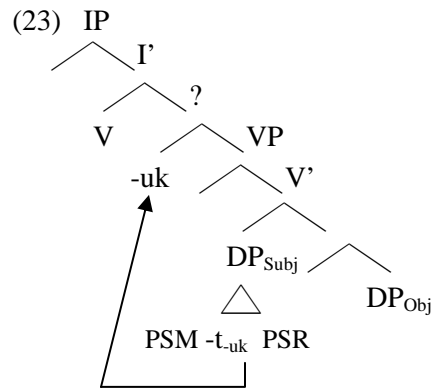

PSR raises out of the possessive subject DP to a position from which it controls agreement. For now I will suggest Spec IP. The lower possessum is still active and controls subject-control.

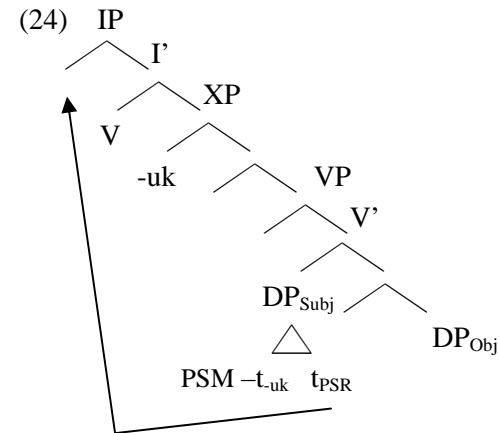

Conclusions:

- Both the surface and logical subjects are active in a PR construction
- *Back to the original question, the raised possessor is not a “subject” in the core sense of Payne and Barshi. Rather it is a “surface subject.”*

IV. Issues for further study

1. What position is the PSR landing in?
2. What position is the possessive marker landing in?
3. What is the structure of the possessive subject DP such that an element can extract out of it?
4. POSS marking on nominal predicates

(25) *That man is my brother* (Wojdak pc)  
 Hajumsiqs-ak-siS Haa jakup-/i  
 brother-POSS-1S.IND DEIC man-DET

**References**

- Braithwaite, Ben. 2003. Syntactic approaches to possessive constructions in Nuuchahnulth. J.C. Brown & Michele Kalmar, eds. The 38th International Conference on Salish and Neighboring Languages. University of British Columbia Working Papers in Linguistics, vol. 11. Vancouver: University of British Columbia Working Papers in Linguistics. 7-22.
- Davidson, Matthew. 2002. Studies in Southern Wakashan (Nootkan) Grammar. PhD dissertation. State University of New York, Buffalo.
- Kim, Eun-Sook. 2000. The Morphology and Syntax of -?at in Nuu-chah-nulth in the Minimalist Theory. In Honour of Professor Young-Jae Lee, ed. Hee-Kyung Moon, pp. 237-281. Korea University Press.
- Nakayama, Toshihide. 2001. Nuuchahnulth (Nootka) Morphosyntax. University of California Publications in Linguistics, vol. 134. Berkeley: University of California Press.
- Payne, Doris L. and Immanuel Barshi. 1999. External Possession: What, Where, How and Why. p 3-29. In External Possession. eds Payne, Doris L. and Immanuel Barshi. John Benjamins: Amsterdam.
- Rose, Suzanne Maria. 1981. *Kyuquot Grammar*. PhD dissertation: Linguistics, University of Victoria. (Nuuchahnulth)
- Wojdak, Rachel. 2004. On the classification of Wakashan lexical suffixes. Proceedings of the 30th meeting of the Berkely Linguistics Society.

Key to Glosses

- Ø - empty  
 1,2,3 - first, second, third person  
 CAUS – causative  
 CONT - continuous  
 DEIC - deictic  
 DET - determiner  
 DUR – durative, formerly IMP (imperfective)  
 INAL - inalienable possessive  
 IND – indicative  
 I.REL – indefinite relative  
 PASS - passive  
 PERF – perfective  
 POSS - possessive  
 PST - past  
 QUOT - quotative  
 REL – definite relative  
 S, PL - singular, plural  
 TEMP – temporal marker, sometimes glossed as “now”