



ADVANCED COMPOSITE STRUCTURES
LABORATORY



UNIVERSITY OF WASHINGTON

Crashworthiness

UW PI: Paolo Feraboli, A&A

UW Students: Bonnie Wade, Max Spetzler

Boeing PI: Mostafa Rassaian, BR&T

FAA PI: Larry Ilcewicz and Allan Abramowitz

JAMS PM: Curt Davies

Presented by Feraboli - Nov. 1, 2011

CMH-17 Crashworthiness Working Group

- *CMH-17 (former MIL-HDBK-17) Working Group supports the development of a self-contained section of the handbook on composite Crashworthiness and Energy Management.*
- *Aim is to generate and present for the first time in a concise and comprehensive fashion, recommended practices and guidelines for the experimental and numerical characterization of the crash behavior of composite-intensive airframes.*
- *Focus of the WG are regulatory agency requirements and industry methods of compliance for crashworthiness certification.*
- *The Crash WG activities have increased every year, drawing larger membership and attendance each meeting.*

Background

- *WG formed in March 2005 at the Charlotte meeting by PF*
- *Automotive and Aviation (Industry & Government) founding members*
- *From its inception, the key areas that were identified for investigation:*
 - *Test standard and experimental guidelines*
 - *Numerical/ analytical guidelines and best practices*
 - *Certification and compliance methodology guidelines*

Context: in March 2005 the Boeing 787 was just launched and the Special condition had not been issued

Revision G Accomplishments

- *In 2005-2006 wrote an introductory section on Composite Crashworthiness, which was approved for publication in the Yellow Pages.*
- *This section now constitutes Chapter 14 in Vol. 3B of Rev. G*

MIL-HDBK-17-3F
Volume 3, Chapter 14 – Crashworthiness and Energy Management

CHAPTER 14 CRASHWORTHINESS AND ENERGY MANAGEMENT

14.1 OVERVIEW AND GENERAL GUIDELINES

14.1.1 Section organization

This chapter of the handbook addresses the multitude of issues associated with the crash performance, energy-absorbing capability, and crashworthiness certification of composite materials and structures. Discussions are heavily reliant on experience gained in the rotorcraft and general aviation industry, since these represent the areas where composites and crash-oriented design philosophy have been most exploited. Whenever possible, reference is also made to the experience gained in the development of open-wheel racecar crashworthy structures, but accessibility to that information is often limited. On the other hand, a substantial portion of the results that will be presented in this chapter was developed during intensive automotive research and development work. As the associated composite technologies continue to evolve, additional applications and service history should lead to future updates with a more complete characterization of the dynamics of the impact event, and of the methodologies employed to achieve the desired crash performance.

Sections 14.2, 14.3, and 14.4, which comprise the bulk of this chapter, address the majority of material and structural responses, as well as design guidelines and analytical efforts. Each section includes detailed discussions of: (a) the major factors that affect the crash response; (b) design-related issues and guidelines for meeting objectives and requirements; (c) testing methods and issues; (d) manufacturing considerations; and (e) analytical predictive methods, and their success in predicting observed responses. Section 14.2 contains a general review of the methods employed in industry and academic institutions to determine the energy-absorbing characteristics of lab-size coupons for material characterization. Section 14.3 concentrates on the static and dynamic crushing response of thin-walled tubular structures, which represent typical current automotive-sized front rails. Section 14.4 focuses on the crashworthy characteristics of cooled-cell structural elements, typical of aircraft fuselage elements.

Section 14.5 includes several examples of successful crashworthy designs from a number of composite aircraft, automotive and rail applications. These examples illustrate how different aspects of crashworthiness come to the forefront as a function of application. They will include the detailed design of a racecar energy-absorbing element, the design of a specific crashworthy fuselage for a prototype aircraft, the development process of a crashworthy primary structure for a production supercar, and the lessons learned in the development of a crashworthy front rail structure of a passenger car.

14.1.2 Principles of crashworthiness

The overall objective of designing for crashworthiness is to eliminate injuries and fatalities in relatively mild impacts, and to minimize them in all severe collisions. A crashworthy vehicle will also control the extent of crash impact damage. By minimizing personnel and material losses, crashworthiness conserves resources, improves effectiveness, and increases confidence of the end-users [14.1.1].

Many influencing parameters need to be considered before an optimum design for crashworthiness can be finalized. A complete systems approach should be employed to include all the parameters concerned with the design, manufacture, overall performance and economic constraints on the vehicle in meeting mission requirements. Trade-offs among these parameters must be made in order to arrive at a final design that closely meets the specifications.

MIL-HDBK-17-3F
Volume 3, Chapter 14 – Crashworthiness and Energy Management

14.1.5 Existing research and development

In the area of aircraft crashworthiness, much of the research focus in the last decades has been directed to the development of composite primary crash structures [14.1.1, 14.1.5, 14.1.5(1)]. Information concerning the inclusion of composite crashworthy features in military rotorcraft is available mainly through US Army-sponsored Research Programs. For example, the fuselage concepts developed during ACAP (Advanced Composite Aircraft Program) and SARAP (Survivable Affordable Repairable Aircraft Program) use a mix of frangible and crushable composite sandwich underfloor structures integral to the composite-resinive airframe [Fig. 14.1.4]. For fixed-wing aircraft, NASA and the FAA have been involved with an extensive research activity to characterize the advantages of retrofitting non-crashworthy designs of General Aviation (GA) aircraft with crashworthy features, as in the case of the Aviation Safety Program (ASP).

Since 1996, the European Union (EU) has funded three research projects (CRAGURV-Commercial Aircraft Design for Crash Survivability, HICAG-High Velocity Impact of Composite Aircraft Structures, and CRAHV-Crashworthiness of Aircraft for High Velocity Impact) concerned with the development and validation of finite element simulation tools to model the crash and impact response of composite energy-absorbing aircraft structures [14.1.12-13]. The focal point of the research effort in CRAGURV was the development of crashworthy fuselage systems, which provide a high-strength structural platform to retain the seats and resist overturning, and a crushable zone to absorb energy and distribute dynamic loads evenly across the fuselage. One particular characteristic of composite aircraft structures that could be a concern to the designer is the intersection of longitudinal fuselage beams and lateral bulkheads. These hard points act as efficient load paths to transfer loads during a crash to the seat and the occupant, and often prevent the occurrence of desirable energy-absorbing failure modes [14.1.14]. The HICAG project focused on testing and modeling of composite materials at high strain rates, while CRAHV dealt with local/global models for complete aircraft simulations as well as impact on different surfaces including water.

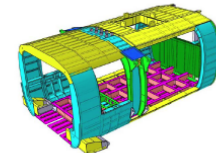

Fig. 14.1.4. Rotorcraft cabin and crashworthy underfloor concept for the Army Survivable Affordable Repairable Composite Airframe Program.

Experimental focus: UW activity

- *UW initial activity focused on test methods*
- *Flat coupon derived from NASA proposed method*
 - “Development of a modified flat plate test and fixture specimen for composite materials crush energy absorption” – Feraboli P. – Journal of Composite Materials, published online July 2008.
- *Self-stabilizing coupon (corrugated/ sinusoidal)*
 - “Development of a corrugated test specimen for composite materials energy absorption” – Feraboli P. – Journal of Composite Materials - 42/3, 2008, pp. 229-256
- *Effect of curvature (from flat to self-stabilizing)*
 - “Crush energy absorption of composite channel section specimens” – Feraboli, P., Wade, B., Deleo, F., Rassaian, M. – Composites (Part A), 40/8, 2009, pp. 1248-1256.

Experimental focus

- *Energy absorption (SEA) is NOT a material property*

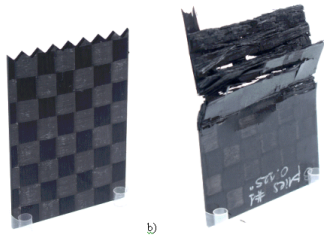

Figure 19 a, b. Flat specimen, before crushing showing the saw-tooth trigger (a), and after crushing (b) at 12.5 mm of unsupported height.

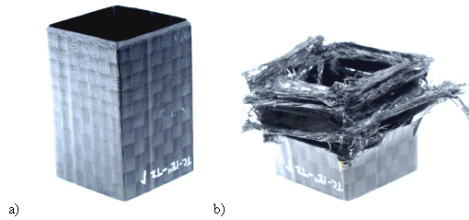

Figure 7 a, b. Square tube, specimen I, before and after crush testing

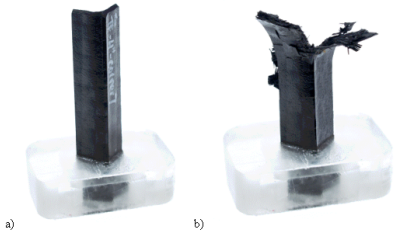
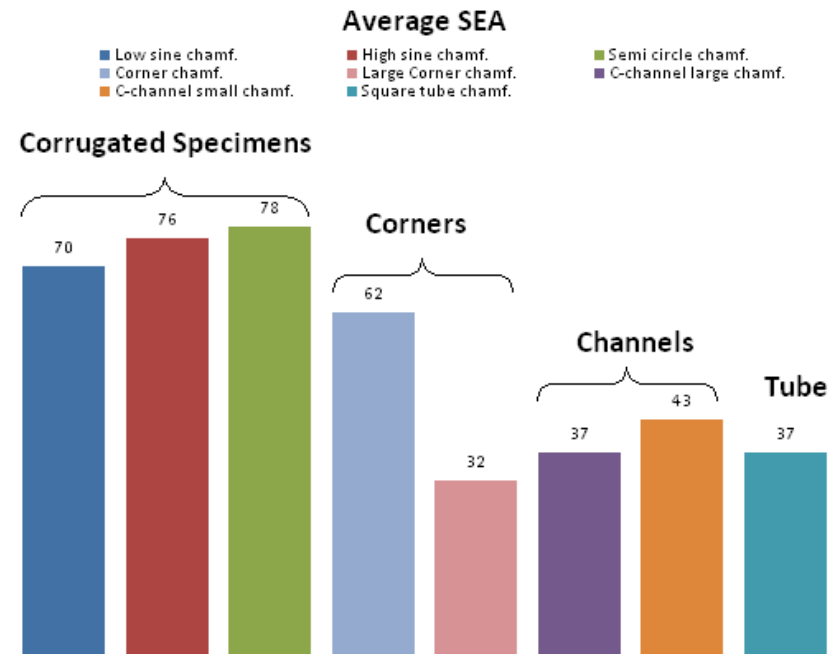
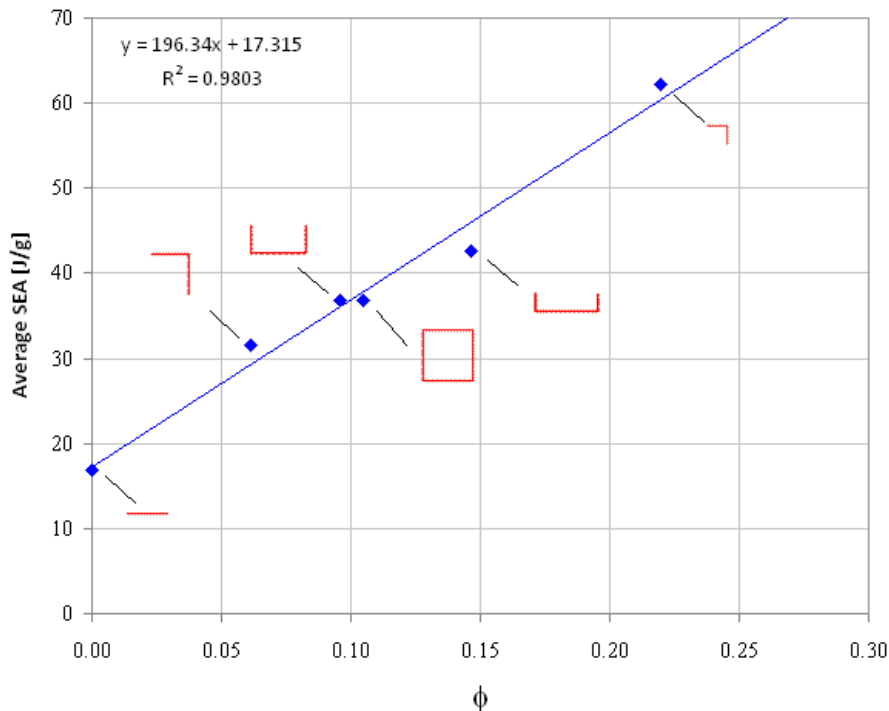

Figure 10 a, b. Small corner element, specimen IV, before and after crush testing



Analysis focus

- *Mostafa Rassaian of Boeing joins at Chicago meeting in July 2006*
- *Emphasis placed on numerical/ analytical needs*
- *Becomes co-chair and spearheads the creation of a Round Robin (RR) exercise to assess predictive capability of commercial FEA codes*
- *Various users with multiple codes and different modeling strategies join the effort*
- *RR begins January 2008 at Cocoa Beach meeting*

FEA Round Robin

- *The RR focuses on evaluating the capability of commercial FEA analysis tools and modeling strategies to simulate the crush energy absorption of composite structural elements.*
- *In 2011-2012 the Numerical Round Robin effort will be completed, and a new section will be incorporated into the Handbook.*

- | | |
|--------------------------------------|---------------------------|
| • LS-DYNA MAT58 | M. Rassaian (Boeing BR&T) |
| • LS-DYNA MAT58
Aihataraju (G.M.) | X. Xiao, V. |
| • LS-DYNA MAT54
Wash.) | P. Feraboli (U. of Wash.) |
| • LS-DYNA MAT162 | R. Foedinger (MSC Corp.) |
| • PAMCRASH CDM | A. Johnson (DLR) |
| • RADIOSS Plasticity | JB Mouillet (Altair) |
| • RADIOSS Tsai-Wu | A. Caliskan (Ford) |

Abaqus VUMAT (Indermuhle) and PAMCRASH crushfront (Pickett) abandoned early on

Roadmap for CMH-17 RR Crashworthiness

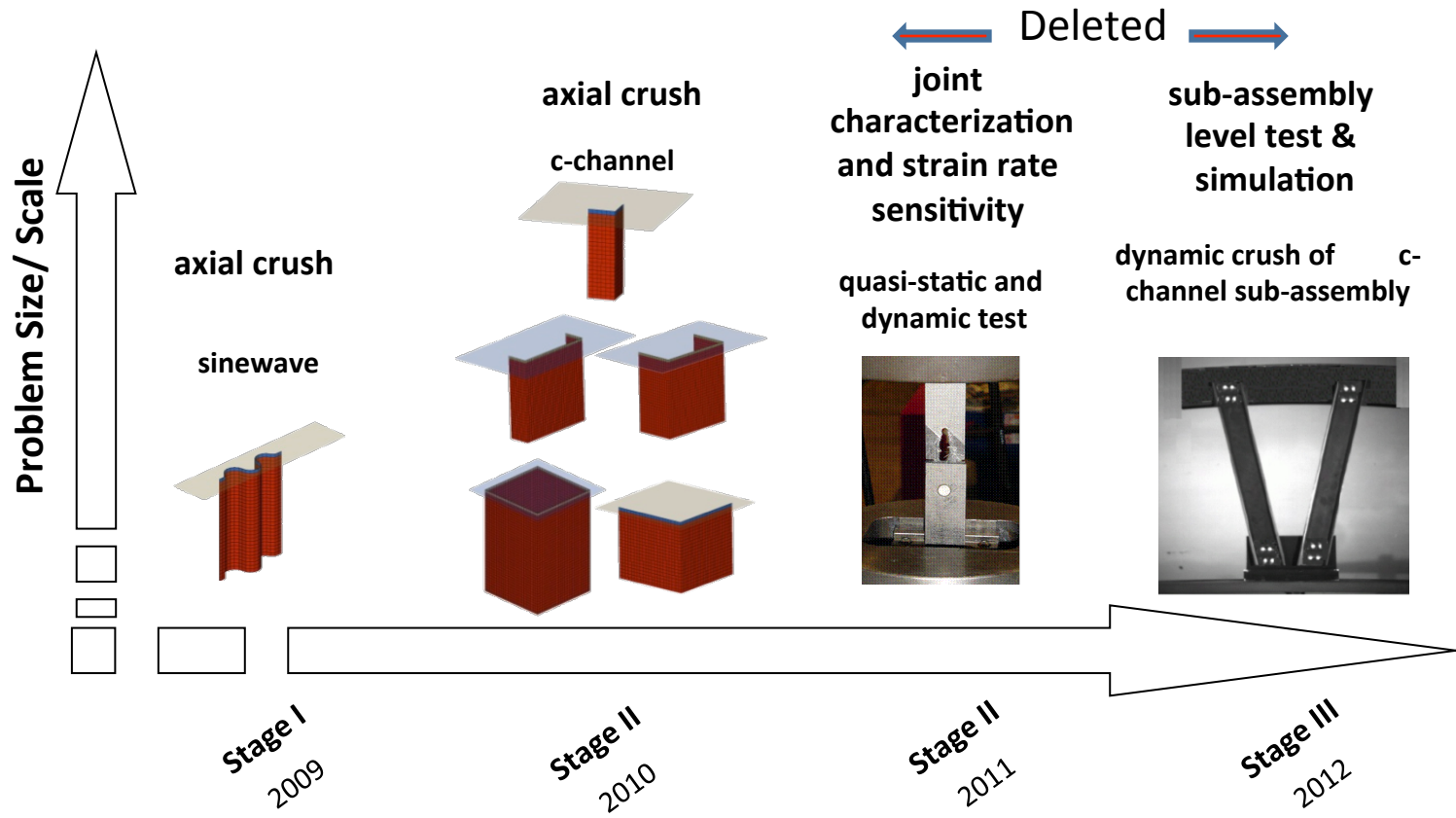

RR observations

- All approaches and codes can reproduce successfully the experimental results (with different accuracy)*

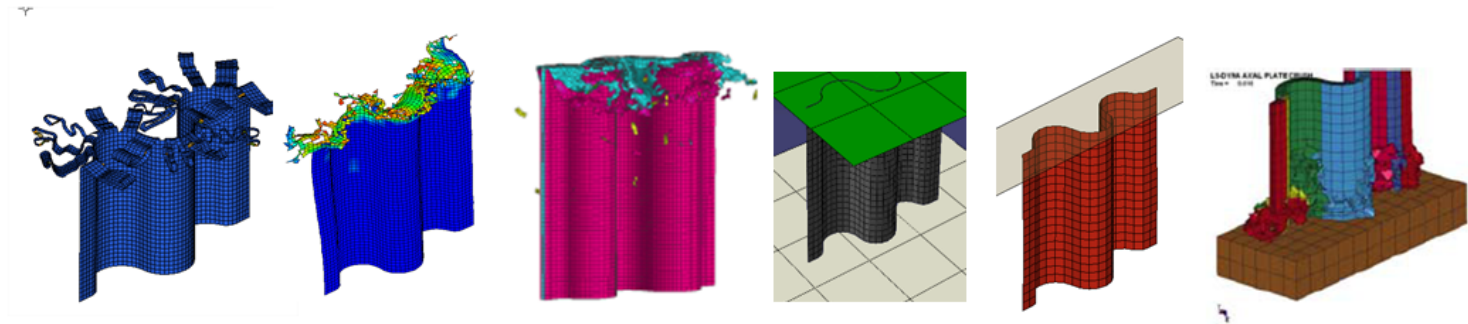
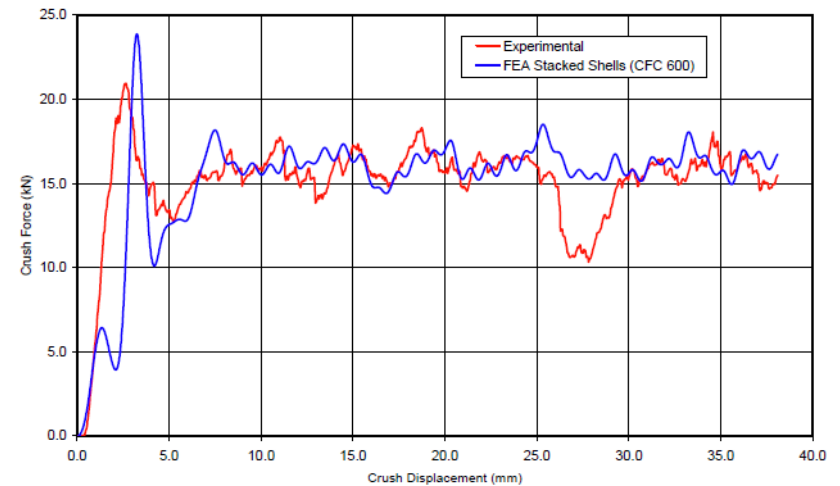
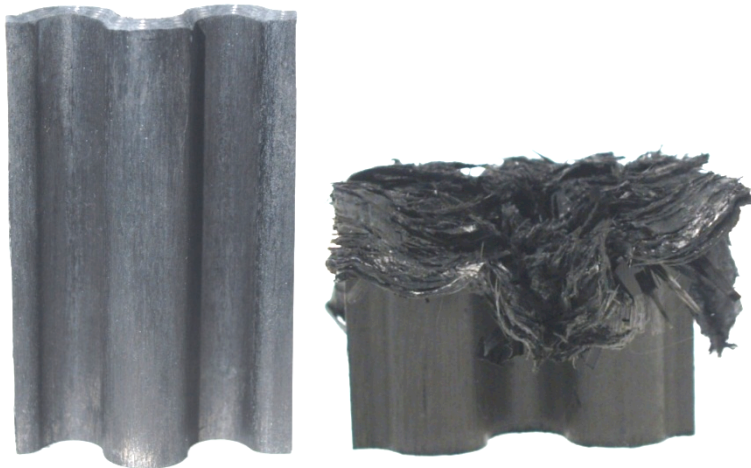

RR observations

- *However, none of them are truly “predictive” but need to be used in the context of a Building Block Approach*

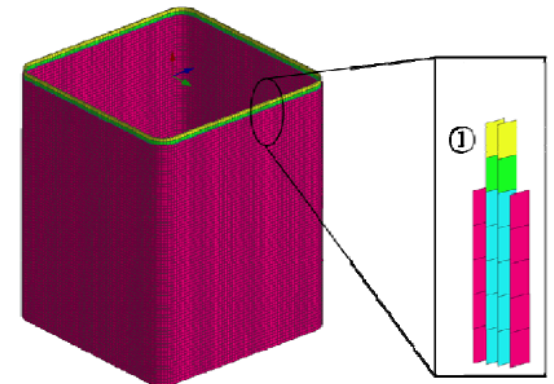
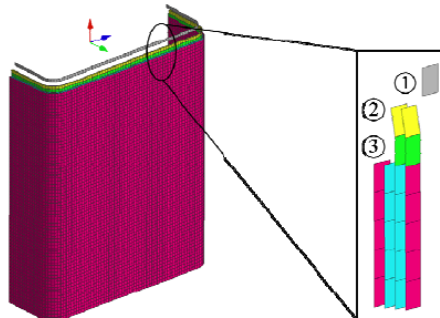
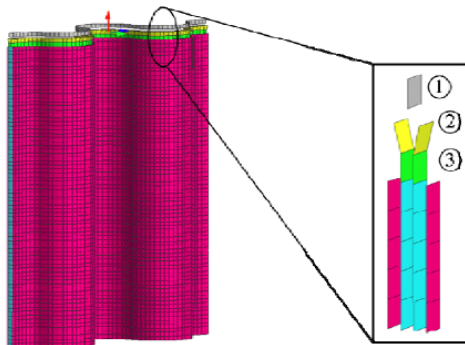
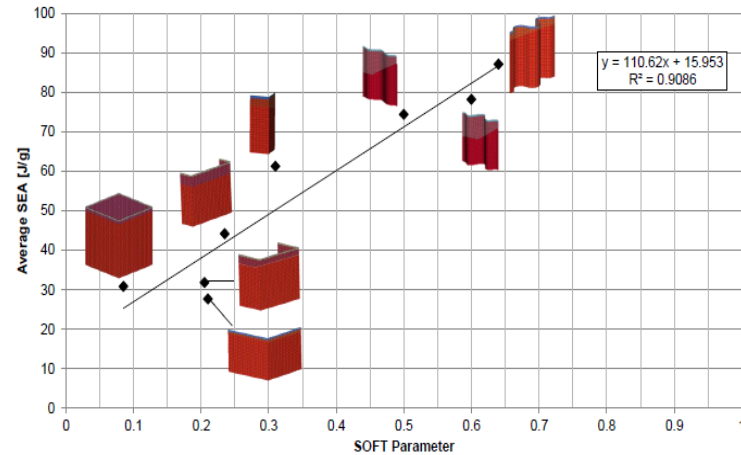
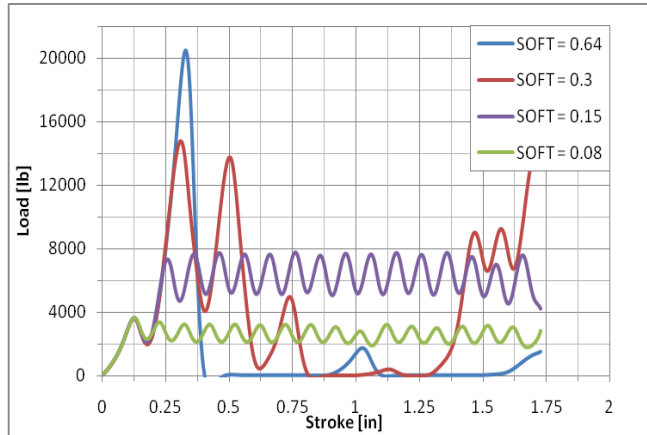

Courtesy: Alastair Johnson (DLR)

LS-DYNA MAT54

- *Began using LS-DYNA MAT54 after advice and based on guidance of Dr. Mostafa Rassaian*
- *No LS-DYNA Capability prior to that at UW ACSL*
- *Assessed robustness of MAT54 to modeling sinusoidal specimen*
 - P. Feraboli, B. Wade², F. Deleo², M. Rassaian¹, M. Higgins¹, A. Byar¹, “LS-DYNA MAT54 modeling of the axial crushing of a composite tape sinusoidal specimen”, Composites (Part A), doi: [10.1016/j.compositesa.2011.08.004](https://doi.org/10.1016/j.compositesa.2011.08.004)
 - Detailed FAA Tech Report submitted and in press

Applications

- Exercise in joint UW-Boeing-Lamborghini effort to predict the crushing of thick sandwich panel
 - P. Feraboli, F. Deleo², B. Wade², M. Rassaian¹, M. Higgins¹, A. Byar¹, M. Reggiani¹, A. Bonfatti¹, L. DeOto¹, A. Masini¹, “Predictive modeling of an energy-absorbing sandwich structural concept using the building block approach”, Composites (Part A), 41/6, 2010, pp. 774-786

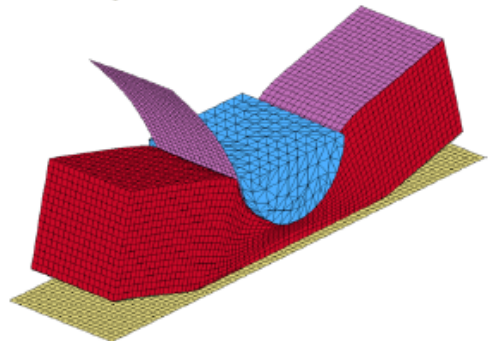
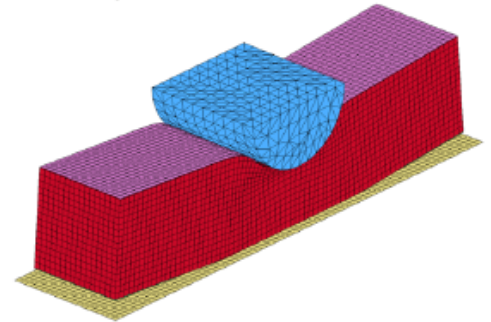
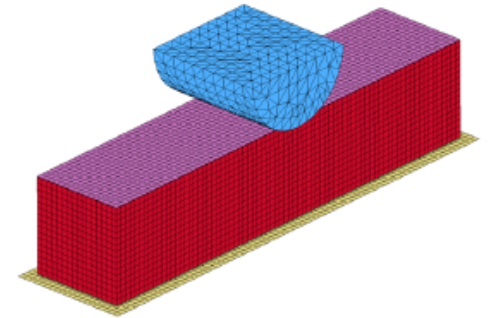
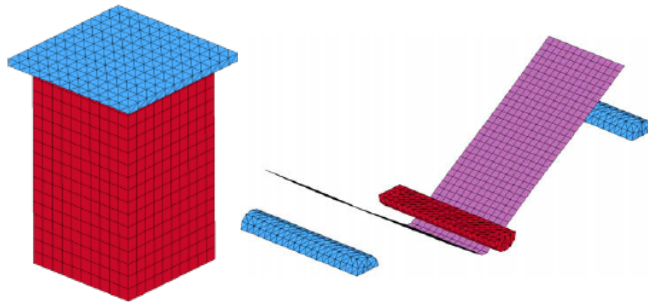

Working Group Membership

- The Working Group has recently been divided in three Task Groups, each focusing on a specific aspect of crashworthiness.*

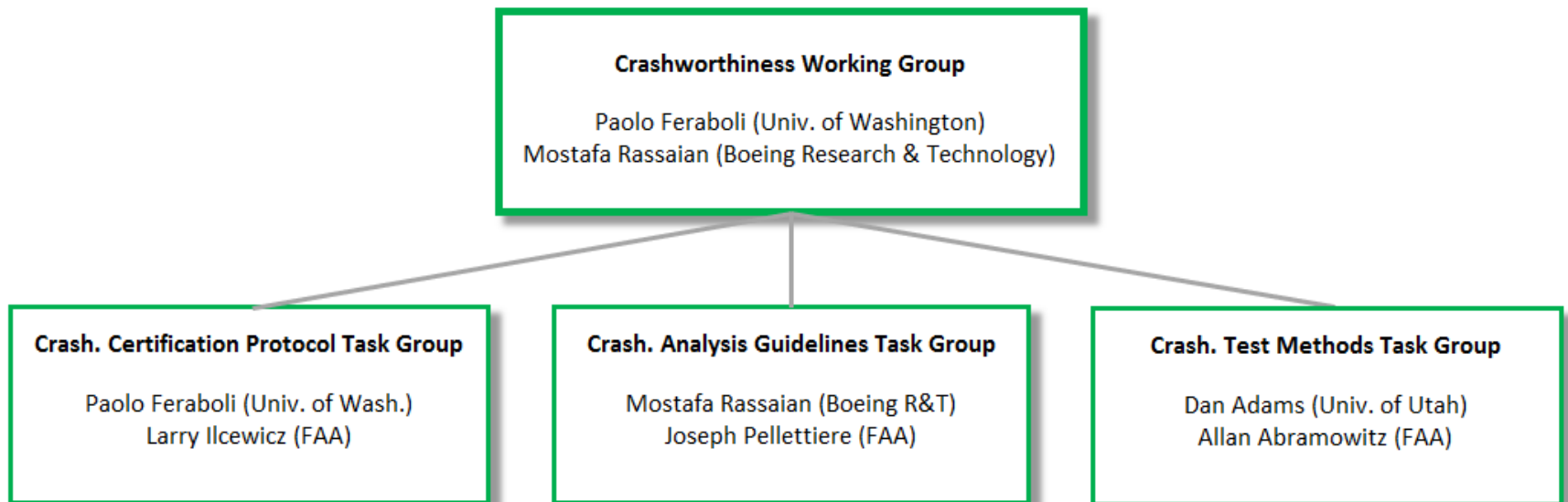

- Very active contributors have also been Karen Jackson (NASA Langley), Kevin Davis (Boeing BCA) and Michael Mahe (Airbus).*

Cert protocol

- *Crashworthiness Certification protocol: Building Block Approach adapted to Crashworthiness*
- *Based on Analysis supported by test evidence*
- *Successfully adopted by Boeing for 787 to meet Special Condition*
- *Cert by test not likely to be an option for Part 25 but may be considered for Part 23*

Courtesy: Boeing

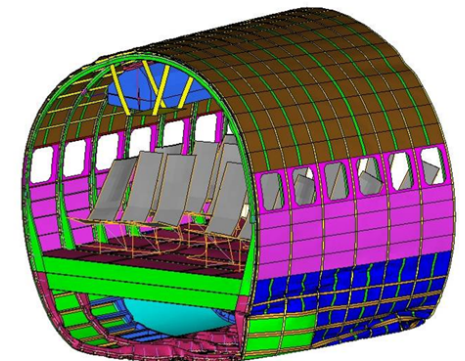

Example of cert protocol

Courtesy: Boeing

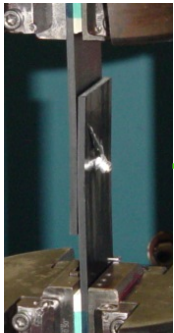

Coupon

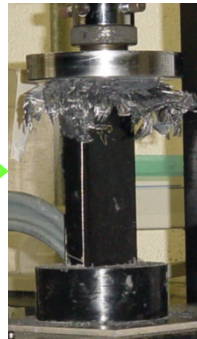

Element

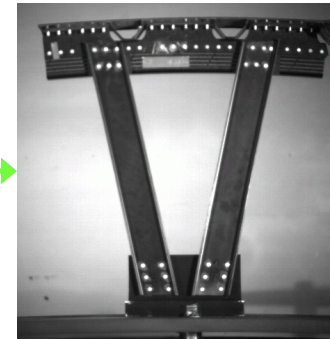

Subcomponent

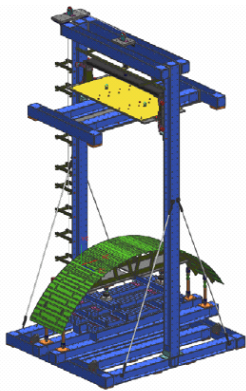

Component

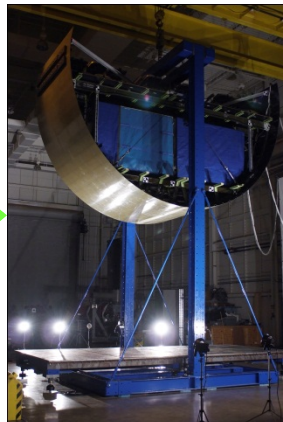

Large scale

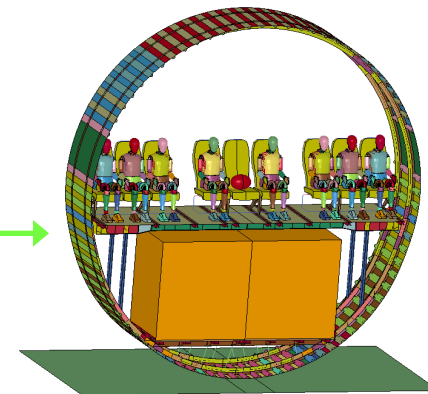
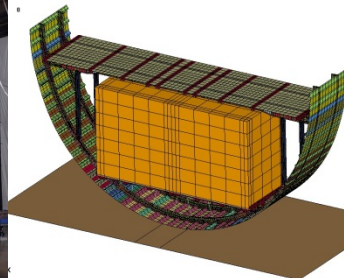

Large scale

Cert protocol

- *Develop a guidance document that contains an example of a certification protocol for Part 25 aircraft based on a generic geometry*
- *Indicate a path toward certification of a virtual aircraft for crashworthiness:*
 - *Certification strategy*
 - *List of Allowables tests*
 - *Definition of Element level tests*
 - *Definition of component and subassembly tests*
 - *Definition of analyses and analysis-correlation procedures*
 - *Validation and large-scale test expectations*

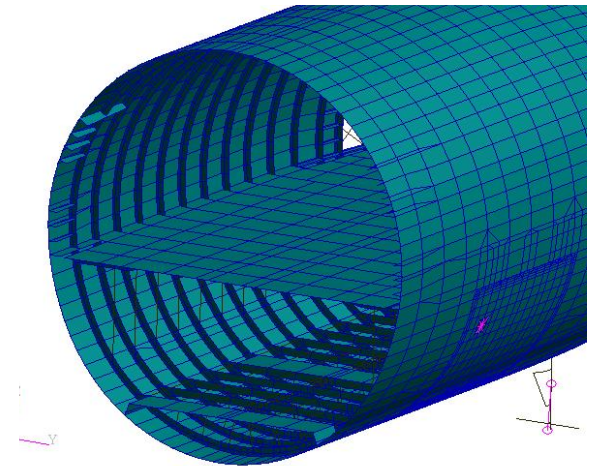
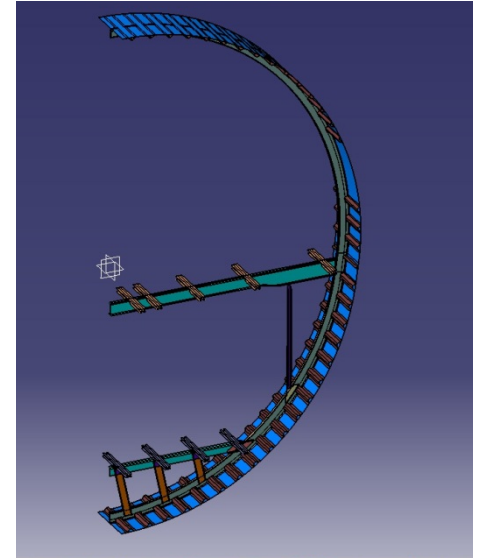

Current efforts of PF

- *Identify a suitable mock geometry, with all relevant structural features (floors, floor beams, floor supports, etc.)*
- *Synthesize the wording of a mock Special Condition into a series of requirements*
- *Define a series of methods of compliance with such requirements*
- *Lay-out the details of the certification protocol for such mock configuration*
- *Aid the FAA in the development of guidance material for crashworthiness certification for the transport industry, and in the preparation of educational/training material for new engineers.*

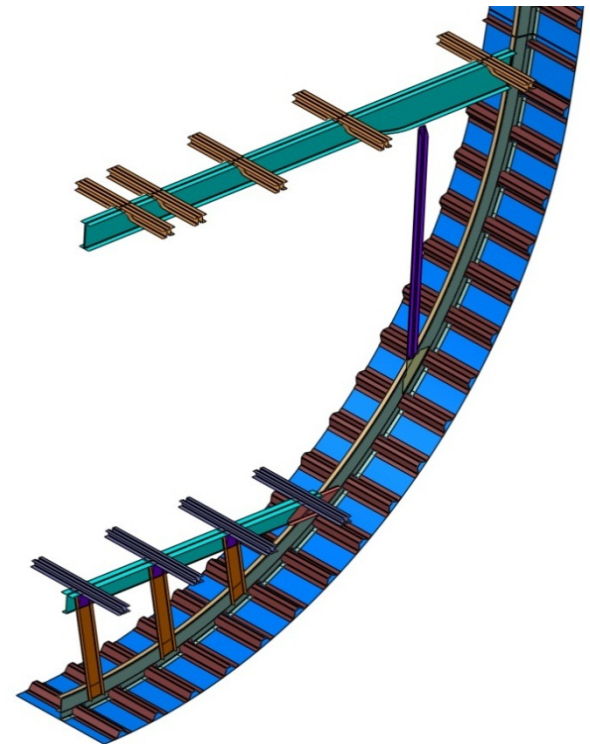

Current efforts of PF

- *Educational Module* (PF)
- *Continue Analysis – Finish MAT54 work* (Bonnie Wade)
- *Cert protocol/ guidelines document* (Max Spetzler)