

Activity of Spinal Interneurons and Their Effects on Forearm Muscles During Voluntary Wrist Movements in the Monkey

STEVE I. PERLMUTTER, MARC A. MAIER, AND EBERHARD E. FETZ

Department of Physiology and Biophysics and Regional Primate Research Center, University of Washington, Seattle, Washington 98195

Perlmutter, Steve I., Marc A. Maier, and Eberhard E. Fetz. Activity of spinal interneurons and their effects on forearm muscles during voluntary wrist movements in the monkey. *J. Neurophysiol.* 80: 2475–2494, 1998. We studied the activity of 577 neurons in the C₆–T₁ spinal cord of three awake macaque monkeys while they generated visually guided, isometric flexion/extension torques about the wrist. Spike-triggered averaging of electromyographic activity (EMG) identified the units' correlational linkages with ≤12 forearm muscles. One hundred interneurons produced changes in the level of average postspike EMG with onset latencies consistent with mono- or oligosynaptic connections to motoneurons; these were classified as premotor interneurons (PreM-INs). Most PreM-INs (82%) produced postspike facilitations in forearm muscles. Earlier spike-related features, often beginning before the trigger spike, were seen in spike-triggered averages from 72 neurons. Postspike effects were present in one muscle for 64% of the PreM-INs. Neurons with divergent linkages to larger "muscle fields" usually generated postspike effects in synergistic muscles. Fifty-eight percent of the PreM-INs had postspike effects in flexor muscles only and 29% in extensor muscles only. Postspike effects were distributed relatively evenly among the primary flexor and extensor muscles studied. The mean percent change in EMG level from baseline and the mean onset latencies for postspike facilitations and postspike suppressions were similar. PreM-INs exhibited a variety of response patterns during the generation of isometric wrist torque. The response patterns and output effects of 24% of the PreM-INs were consistent with a strict reciprocal organization of flexor and extensor muscle control. For another 60% of the PreM-INs, there was a congruent relation between activity and output effects for only one direction of torque production. These neurons were active for both flexion and extension torques, including 37 neurons that exhibited bidirectional increases in discharge rate. The relatively small number of postspike suppressions observed suggests that inhibitory interneurons were silent when their target muscles were recruited. Compared with premotor neurons in the motor cortex, the red nucleus and the C₈–T₁ dorsal root ganglia, spinal PreM-INs affected flexor muscles in greater proportions and had smaller muscle fields. The magnitudes of postspike facilitations were similar in all premotor populations. Bidirectional activity, common for PreM-INs, was rare for corticomotoneuronal and premotor dorsal root ganglion cells, which discharge only for torques in their preferred direction.

INTRODUCTION

Supraspinal control of voluntary limb movements is mediated in large part by descending projections to spinal interneurons. Anatomic studies have demonstrated substantially denser projections from cortical and brain stem motor areas to intermediate spinal laminae than to motor nuclei (Armand et al. 1997; Bortoff and Strick 1993; Cheema et al. 1984;

Dum and Strick 1996; Kuypers 1981; Ralston and Ralston 1985; Robinson et al. 1987). Spinal interneurons appear to integrate convergent supraspinal and peripheral afferent information and distribute appropriate signals to motoneurons to activate muscles in coordinated patterns (Baldissera et al. 1981; Jankowska 1992).

Although mammalian spinal pathways have been examined extensively since Sherrington's reflex studies in the early 1900s (Sherrington 1910), virtually all physiological investigations have been performed in anesthetized or reduced preparations. Of the few descriptions of interneuron properties in awake animals, most concern sensory responses (Bromberg and Fetz 1977; Cleland and Hoffer 1986; Collins et al. 1990; Courtney and Fetz 1973; Soja et al. 1996; Sorkin et al. 1988; Wall et al. 1967). Other studies have reported the activity of some spinal interneurons during fictive locomotion and scratching (Berkowitz and Stein 1994; Jordan 1991; Terakado and Yamaguchi 1990) or inferred the activity of interneurons during normal movements from analyses of muscle responses, limb kinematics, or force (e.g., Nielsen and Kagamihara 1992; Pierrot-Deseilligny 1989; Shefner et al. 1992; Stein and Kearney 1995).

These investigators have characterized reflex circuitry and proposed hypotheses about the functions of specific spinal pathways during voluntary movement. However, two important properties of spinal interneurons are difficult to elucidate in these types of experiments: the activity patterns of spinal neurons under normal conditions of active behavior and the effect of individual neurons on muscle activation (Brink et al. 1983; Hongo et al. 1989; Jankowska and Roberts 1972; Rudomin et al. 1987; review in Cheney et al. 1991). Consequently, despite the crucial role of spinal interneurons in the control of voluntary movements, many basic questions concerning their function during normal behaviors remain unanswered.

To address these issues, we recorded the activity of neurons in the cervical cord of awake monkeys while they performed a trained forearm task. The methods were adapted from earlier studies of the spinal cord and dorsal root ganglia of awake primates (Bromberg and Fetz 1977; Courtney and Fetz 1973; Flament et al. 1992). This paper focuses on the output properties of spinal premotor interneurons (PreM-INs), identified with spike-triggered averages of muscle activity (Fetz and Cheney 1980). The companion paper (Maier et al. 1998) describes the responses of PreM-INs and other spinal neurons during movement and their relation to force produced at the wrist.

METHODS

Spinal interneurons were studied in three male macaque monkeys (2 *Macaca nemestrina* and 1 *M. mulatta*). The experiments were approved by the Animal Care Committee at the University of Washington. All procedures conformed to the National Institutes of Health "Guide for the Care and Use of Laboratory Animals."

During training and recording sessions, the monkeys sat upright in a primate chair adjusted for each animal. The working arm was restrained with the elbow bent at 90°. The hand was held with the fingers straight and the wrist in the midsupination/pronation position. The flexion/extension axis of the wrist was aligned with the shaft of a torque transducer. The other arm was restrained loosely.

Behavioral paradigm

The monkeys were trained to generate isometric, ramp-and-hold flexion and extension torques about the wrist. Torque controlled the position of a cursor on a video screen in front of the animal. To obtain a fruit juice or applesauce reward, the monkeys held the cursor for 1.5–2 s within a target window that specified a given flexion or extension torque ≤ 0.2 N·m. For *animals B* and *R*, the target windows alternated back and forth between fixed flexion and extension levels. These animals produced ramp-and-hold torques in each direction starting from a maintained torque in the opposite direction (Fig. 1A). *Monkey W* began each trial by positioning the cursor within a center target window, corresponding to zero torque, for 1–4 s. Then a target window appeared at one of six positions randomly selected from three flexion and three extension levels. *Monkey W* produced ramp-and-hold torques in each direction starting from rest (Fig. 1B).

Surgical implants

All surgeries were performed with the use of aseptic techniques with the animals under 1–1.5% halothane or isoflurane anesthesia after training was completed. Atropine sulfate was administered preoperatively; antibiotics (cefazolin, 25 mg/kg) and analgesics (ketoprofen, 5 mg/kg) were given postoperatively. Head stabilization lugs were cemented to the exposed skull with dental acrylic, which was anchored to the bone with screws.

A stainless steel recording chamber was implanted over the lower cervical spine (Fig. 2). Following a midline incision, soft tissue was retracted to expose the lateral masses of the midcervical to upper thoracic vertebrae. The dorsal spinous processes of the C₄–T₂ vertebrae were removed and a unilateral laminectomy of C₅–T₁ was performed. Each lamina was removed with a rongeur from its junction with the facet to just past the midline. Bone screws were introduced into the vertebrae, and the recording chamber was positioned over the laminectomy and cemented in place with dental acrylic. The skin and underlying soft tissue were pulled tightly in layers around the chamber with purse-string sutures. The outer surface of the skin was held in contact with the underside of a small flange near the top of the chamber, protecting the exposed skin margin. The chamber was closed at all times with a protective cap except during recording sessions.

In *monkeys B* and *R*, vitalium screws were inserted into the intact C₄–T₂ laminae and the implant remained stable for ~2 mo. In *monkey W*, the stability of the implant was extended to 6 mo with the surgical technique of Anderson et al. (1991) (Fig. 2).

The implant procedure fused the C₄–T₂ vertebrae. After recovery from surgery, the monkeys exhibited a stiffened posture of the upper back, but showed no signs of discomfort nor any neurological symptoms. The animals' behavior in their home cages returned to near normal and their performance at the trained task quickly reached preoperative levels.

Bipolar electromyographic electrodes were implanted in 10–14 forearm muscles. In *monkey W*, patch electrodes (Microprobe,

Clarksburg, MD) and multistranded stainless steel wires were sutured to surgically exposed muscles with the monkey under isoflurane anesthesia. Connecting wires were led subcutaneously to a multicontact socket connector cemented to the skull. In *monkeys B* and *R*, wire pairs were inserted transcutaneously with the animals under ketamine anesthesia; external wires and connectors were taped to the upper arm and concealed in a jacket worn by the monkey. Replacement of transcutaneous electrodes every 2–4 wk ensured recording quality.

Muscles were identified on the basis of their anatomic location and characteristic movements elicited by trains of low-intensity intramuscular stimuli. Pairs of electrodes were implanted in primary extensor and flexor muscles of the wrist: extensor carpi ulnaris (ECU), extensor carpi radialis (ECR), extensor digitorum communis (EDC), extensor digitorum-2,3 (ED-2,3), extensor digitorum-4,5 (ED-4,5), flexor carpi radialis (FCR), flexor carpi ulnaris (FCU), flexor digitorum profundus (FDP), flexor digitorum superficialis (FDS), and palmaris longus (PL). Other muscles with secondary actions at the wrist were recorded frequently. Pronator teres (PT) was active primarily in flexion, abductor pollicis longus (APL) and supinator (SUP) were active primarily in extension, and brachioradialis (BR) was active in either or both directions for different animals.

Recording procedure

During recording sessions, the head and vertebral implants were secured to the primate chair with nylon screws. The implants were held firmly, but both restraints were somewhat flexible, allowing the animal to make small postural adjustments. *Monkey B* received occasional intramuscular injections of diazepam (2–4 mg) to eliminate excessive movements that jeopardized stable neuronal recordings. These procedures were well tolerated: all monkeys moved voluntarily from their home cages and seated themselves in the primate chair for each day's session.

An X-Y positioning stage and microdrive were mounted on the chamber (Fig. 2). Activity of neurons in the C₆–T₁ spinal segments was recorded extracellularly with glass-insulated tungsten or Elgiloy electrodes advanced through the dura mater under direct visual observation through a dissecting microscope. Neurons were isolated while the monkey performed the isometric wrist task for 2–5 h/day. Stable recordings of individual neurons could be maintained for >30 min when the monkey sat quietly. As many as 100 tracks were made in each animal during a period of 2–6 mo. None of the animals exhibited observable behavioral deficits at any time.

Spike-triggered averaging of electromyographic activity

Action potentials of individual spinal units were monitored and pulses generated by a time-amplitude window discriminator (Bak Electronics). Electromyographic activity (EMG) was recorded differentially and band-pass filtered (30 Hz to 3 kHz). The action potentials of isolated neurons were used to trigger averages of EMG to identify functional connections to muscles (Fetz and Cheney 1980). Spike-triggered averages (STAs) of full-wave rectified and occasionally unrectified EMGs, digitized at 4 kHz, included ≥ 20 ms before the trigger time. Only interneurons with STAs compiled from >2,000 triggers were included in the data set; previous experience has demonstrated that such STAs show reproducible effects (Fetz and Cheney 1980; Fetz et al. 1989; Flament et al. 1992; Mewes and Cheney 1991). STAs from putative motoneurons revealed consistent features in averages from less spikes, often with only a few dozen triggers (Maier et al. 1998).

Baseline activity was defined as the average EMG level in the first 10–15 ms of the STA. Spike-related changes in EMG were identified as sustained levels above (facilitation, Fig. 3A) or below (suppression, Fig. 3B) 2 standard deviations (SD) from the baseline mean. The onset and offset latencies of these features were

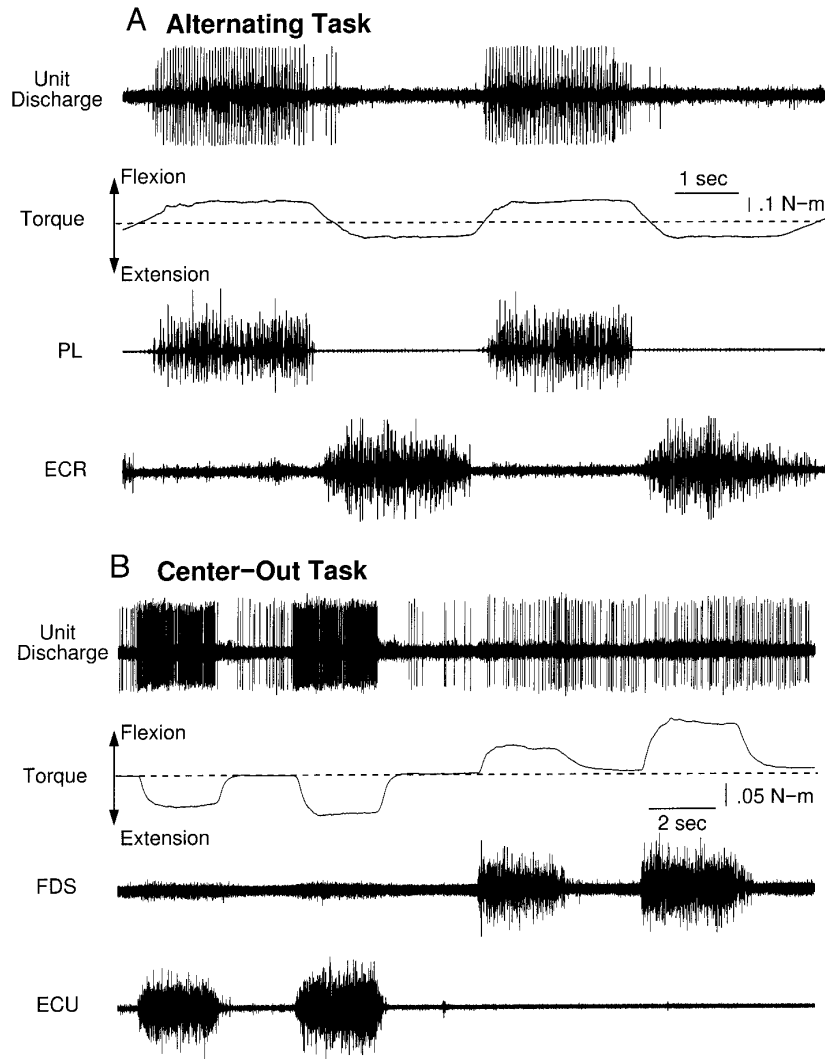

FIG. 1. Behavioral paradigms and discharge patterns of 2 spinal interneurons during the alternating (A) and the center-out (B) tasks. Traces show simultaneously recorded action potentials of the interneuron, isometric torque trajectory, and electromyogram (EMG) of 1 flexor and 1 extensor muscle.

defined as the times from the start of the averaged trigger spike to the first and last bins, respectively, that crossed the 2 SD level. STA features could have onsets after (Fig. 3A) or before (Fig. 3B) the triggering spike. The peak latency was defined as the time from spike onset to the highest (for facilitatory effects) or lowest (for suppressive effects) point in the STA feature. Two measures were used to quantify the magnitude of the output effects

mean percent change

$$= \frac{\text{mean level between onset and offset of output effect} - \text{baseline mean}}{\text{baseline mean}} \times 100$$

peak percent change

$$= \frac{\text{peak level of output effect} - \text{baseline mean}}{\text{baseline mean}} \times 100$$

Facilitatory effects were characterized by the mean and peak percent increase in EMG (MPI and PPI) and suppressive effects by the mean and peak percent decrease (MPD and PPD).

Two distinct types of features were superimposed in the STA of some muscles: a sharply rising or falling postspike effect super-

imposed on a broad change in average EMG with an earlier onset (Fig. 3C; see RESULTS). The latency and magnitude of the postspike and early components were calculated separately. The onset and offset of the postspike effect were identified visually as sharp increases or decreases in average EMG that clearly deviated from the underlying early effect (Fig. 3C). Superimposed features were considered to be separate effects only if they exceeded 2 SD of the mean activity preceding the sharp transition in slope (after the underlying profile of the early effect was subtracted, if appropriate). The mean and peak changes of the postspike effect were measured relative to a base level defined as the average of the EMG levels at the onset and offset times. The magnitude of the early effect was calculated after the postspike effect was replaced with a constant value equal to its base level.

The significance of the STA features was determined by means of a *t*-test between the data in the baseline and the spike-related effect. The neuron was considered to have an effect on muscle activity if the mean levels during these epochs were significantly different at the $P < 0.01$ level.

Cross-talk between muscle recordings

Electrical cross-talk between electrodes in two muscles can produce significant features in the STA of one muscle that are actually

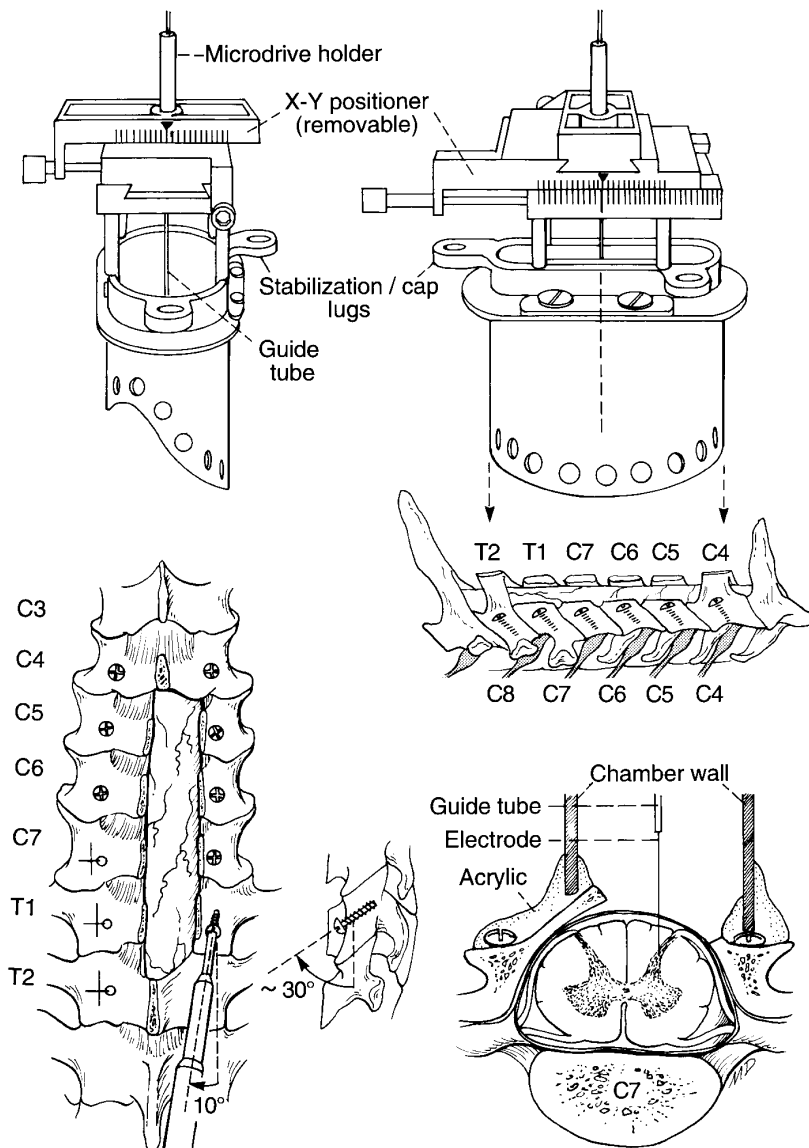

FIG. 2. Schematic diagrams of the surgical procedure for implanting a stainless steel chamber over a unilateral laminectomy of the C₅-T₁ vertebrae and of the system for advancing metal recording electrodes through the chamber into the spinal cord.

due to spike-related effects in the other muscle (Fetz and Cheney 1980; Lemon et al. 1986). This cross-talk confounds estimates of the distribution of effects of individual interneurons to different muscles and was identified by cross-correlating muscle activity.

Motor-unit potentials that exceeded the electrical noise level were used to trigger averages of rectified EMG from all muscles, including the trigger muscle itself. The ratio of the amplitude of the central peak in the averaged EMG of a nontrigger muscle to the peak amplitude of the self-triggered average was used as a measure of the independence of two EMG recordings. Central peaks also could be produced physiologically by synchronous activation of motor units in the two muscles, as commonly occurs in finger muscles of human subjects (Bremner et al. 1991a,b; DeLuca and Mambrito 1987). We chose the following criterion to distinguish synchronous firing of motoneurons from electrical cross-talk. All spike-related effects in muscles for which the amplitude ratio was $>15\%$ were excluded as redundant. Neurons for which STAs were compiled with three or more independent, coactive muscles are included in the data set (average was 4.6 independent, coactive muscles for both flexors and extensors).

Response averages

To characterize task-related modulation, we averaged the activity of isolated units over many trials of ramp-and-hold torque production. Histograms of neuronal activity and analog averages of rectified EMG and torque (8-ms bins) were compiled separately for flexion and extension trials, aligned on the onset of the torque ramps. Torque in the flexion direction is represented in all figures as a positive deflection; extension torques are shown as negative. Response patterns were assigned to describe the profile of averaged neural activity (Maier et al. 1998).

Microstimulation

Microstimuli were frequently delivered through the recording electrode to determine output effects evoked at localized sites within the cord. Single-pulse stimuli (200- μ s biphasic pulses) of $\leq 50 \mu$ A were used to trigger averages of EMG. Stimulus-triggered averages were analyzed in the same manner as STAs for isolated

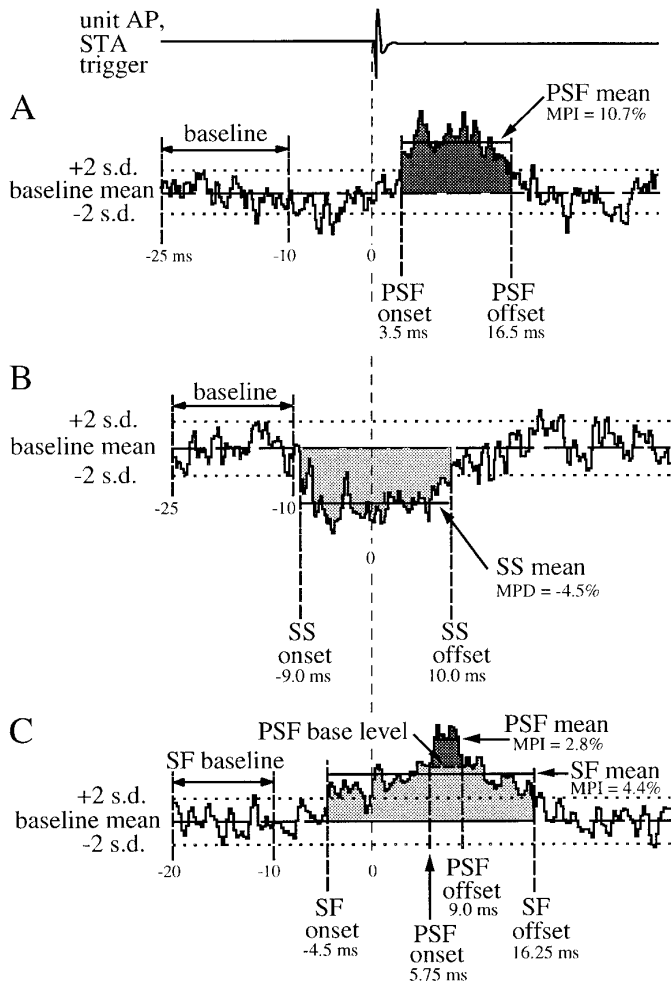

FIG. 3. Methods for quantifying 3 types of spike-related effects in spike-triggered averages (STAs) of rectified EMG. *A*: postspike facilitation (PSF). *B*: synchrony suppression (SS). *C*: PSF superimposed on synchrony facilitation (SF). *Top*: action potential that triggered the STA in *A*. Significant effects had sustained increases or decreases in average EMG above or below the baseline mean ± 2 SD.

units; however, stimulus-triggered averaging yielded reproducible poststimulus features with far fewer triggers, often <10 .

Histological procedures

Near the conclusion of each experiment, we made small electrolytic lesions at several sites within the spinal cord by passing DC current (10–30 μA for 1–2 min) through the recording electrode. Animals were euthanized with pentobarbital sodium (50 mg/kg *iv*) and perfused with 10% Formalin or 4% paraformaldehyde. The spinal cord was cut into 75- μm sections, which were stained alternately with cresyl violet and Perls iron reaction for the detection of iron deposits made with Elgiloy electrodes.

RESULTS

Neurons were recorded in the C₆–T₁ spinal segments of three monkeys. Cells exhibiting spontaneous activity while the monkey sat quietly with no visual targets displayed were encountered at all depths of the gray matter. Firing rates were generally higher for dorsal horn cells and ranged widely for cells in the intermediate layers. Spontaneous firing rates ranged from <1 to

>100 spikes/s. A few neurons exhibited activity modulated in phase with the monkey's respiratory or cardiac cycles.

The activity of 572 neurons (22, 141, and 409 neurons from monkeys *R*, *B*, and *W*, respectively) was modulated during the isometric wrist task (Fig. 1). These cells were located throughout the gray matter, although more commonly in laminae VI–VII and IX. Twenty-nine cells were classified as motoneurons. They were recorded at depths below ~ 2 mm from the surface of the cord and had wide action potentials, low firing rates, and unidirectional activity. Motoneurons are described in the companion paper (Maier et al. 1998) and are not considered further here.

Spike-related effects on muscles

For 134 neurons, STAs revealed significant changes, above or below baseline fluctuations, of spike-related EMG from forearm muscles. Firing rate was modulated during the task for 129 of the neurons and unmodulated for 5. The onset latencies of the STA features were distributed broadly, ranging from 34 ms before to 24 ms after the trigger spike. *Postspike effects* were defined as sustained changes of average EMG level with onset latencies consistent with mono- or oligosynaptic connections to motoneurons. *Early spike-related effects* with shorter latencies were attributed to other mechanisms (see DISCUSSION).

Postspike effects were distinguished from earlier effects by a latency criterion based on the output effects elicited by intraspinal stimuli. Single-pulse microstimulation in the C₆–T₁ segments often elicited responses in forearm muscles that were detected by stimulus-triggered averaging (Fig. 4*A*). Stimuli were delivered at sites throughout the intermediate and ventral laminae, occasionally at locations where isolated neurons were recorded. The distribution of onset latencies of 884 poststimulus effects elicited from 117 sites in monkeys *W* and *B* with stimuli of ≤ 30 μA is shown in Fig. 4*B*.

The earliest facilitatory effects probably were due to the direct excitation of the proximal regions of motoneuron axons. The latency of these effects includes the delay between stimulus onset and neuron discharge, commonly called the utilization time. Figure 4*C* shows an example of stimulus utilization time for a motoneuron, comparing the latencies of its motor-unit profile in a STA and in a stimulus-triggered average elicited with single-pulse microstimulation at the recording site. Gustaffson and Jankowska (1976) found that cat lumbar motoneurons typically were activated 0.2 ms after an extracellular stimulus, and we adopted this value as an estimate of stimulus utilization time for cervical motoneurons in the macaque.

Subtracting 0.2-ms utilization from the earliest poststimulus latency (2.8 ms, Fig. 4*B*) gives an estimate of 2.6 ms as the earliest possible onset time for a motor-unit potential in a STA triggered by a motoneuron. A last-order interneuron could produce a postspike effect in a STA with a slight additional delay, which we estimated to be 0.9 ms: 0.4 ms for conduction time along the interneuron axon (assuming a short conduction distance), 0.3 ms for synaptic delay at the motoneuron synapse (Jankowska and Roberts 1972), and 0.2 ms between the onset of the excitatory postsynaptic potential (EPSP) and spike initiation in the motoneuron (Cope et al. 1987; Gustaffson and Jankowska 1976). Thus we estimated that the synaptic effect of a last-order interneuron on motoneurons could produce postspike effects in STAs of EMG with latencies of ≥ 3.5 ms.

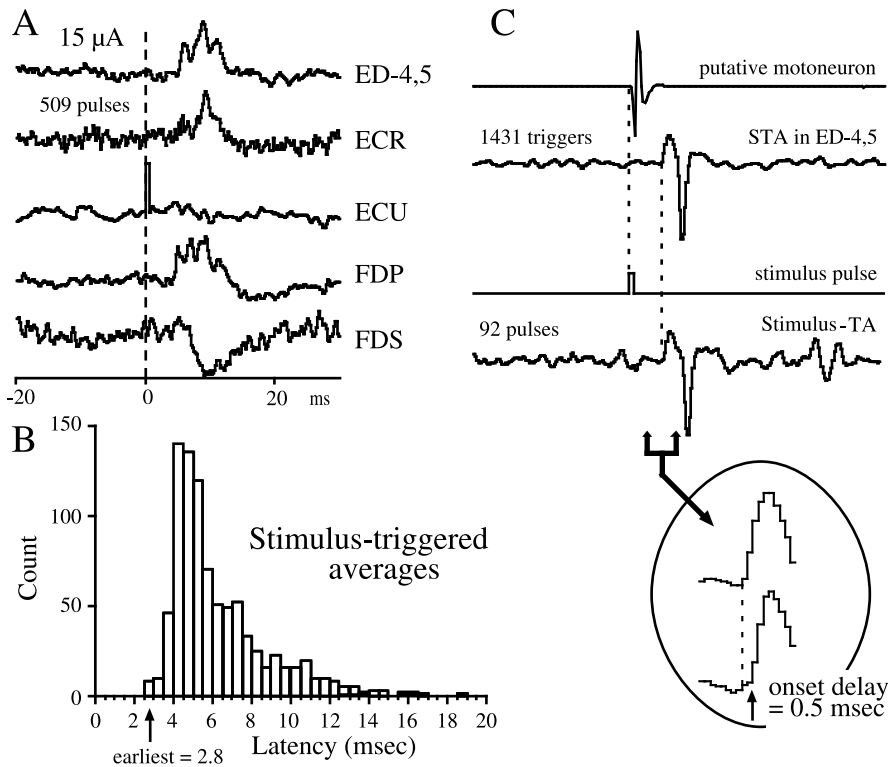

FIG. 4. Determination of the latency criterion for postspike effects based on output effects elicited with microstimulation in the spinal cord. *A*: example of poststimulus effects in forearm muscles. *B*: histogram of onset latencies of effects elicited from 117 stimulation sites with intensities of $\leq 30 \mu\text{A}$. *C*: comparison of onset latencies of the postspike effect of a putative motoneuron (4.0 ms) and the poststimulus effect elicited with $5\text{-}\mu\text{A}$ stimulation at the recording site (4.5 ms). Averages compiled with unrectified EMG show an apparent single motor unit potential. Records are 50 ms long. Difference in postspike and poststimulus latencies attributed to stimulus utilization time.

Neurons were classified as PreM-INs if at least one muscle had a spike-related effect with an onset latency of ≥ 3.5 ms. We use the term "premotor" to indicate a functional linkage to motoneurons rather than a direct anatomic connection. The majority of postspike effects probably are produced by monosynaptic connections to motoneurons (Fetz and Cheney 1980). However, the range of conduction times for motor axons makes it impossible to determine with certainty if our longer latency postspike effects are mediated by mono- or oligosynaptic connections. A last-order interneuron with monosynaptic connections to slowly conducting motoneurons could produce postspike effects with onset latencies equal to, or longer than, those produced by a PreM-IN with disynaptic connections to very fast conducting motoneurons.

We are sure that the earliest postspike effects were mediated by monosynaptic contacts on motoneurons. We estimated that an additional synapse between a PreM-IN and a motoneuron would add a delay of ≥ 1 ms to the earliest possible latency for postspike effects on EMG (0.5-ms conduction along the PreM-IN axon, 0.3-ms synaptic delay, 0.2-ms EPSP-spike initiation in the interposed interneuron). Thus postspike effects with onset latencies of ≥ 3.5 and < 4.5 ms were certainly due to monosynaptic connections to motoneurons. PreM-INs that produced a postspike effect in at least one muscle with a latency of < 4.5 ms were classified as last-order interneurons. Although longer latency postspike effects could be mediated by oligosynaptic connections, the majority are likely to be monosynaptic (see DISCUSSION).

Postspike effects

One-hundred neurons were classified as PreM-INs on the basis of appropriately timed postspike facilitation or suppression of EMG in at least one muscle. Eighteen of these PreM-

INs met the stringent criterion for classification as last-order interneurons. The population of PreM-INs produced 161 postspike effects, 20 of which had latencies of < 4.5 ms. Neurons classified as last-order interneurons had properties similar to those of other PreM-INs, and the populations are combined for most of the subsequent description of results. Last-order and other PreM-INs are described separately only when their properties differed significantly from each other.

Figure 5 shows the STAs and response average for a facilitatory interneuron located in lamina VII of the caudal C_8 segment. This cell discharged tonically during static torques in both directions with a higher rate for flexion torques (*top right*). The STAs of EMG for three coactive muscles reveal sharply rising postspike facilitations in the PT and FCU muscles and no effect in FDP.

Data from an inhibitory PreM-IN located in the rostral T_1 segment are shown in Fig. 6. This neuron exhibited a phasic increase in discharge during extension torque ramps, superimposed on a steady background firing rate. The STAs show a postspike suppression of the ED-4,5 muscle.

Postspike effects did not always appear on flat baseline activity as in Figs. 5 and 6. The STAs of 25 PreM-INs exhibited postspike facilitations that were superimposed on broader, more slowly rising changes in EMG with onset latencies of < 3.5 ms. The neuron in Fig. 7 produced postspike facilitations in three independently recorded flexor muscles (Δ). In FDS and FCU, these effects were superimposed on early facilitations with onset latencies of -5.0 and -0.6 ms, respectively (\blacktriangle). The STAs of the neuron in Fig. 8 showed large early facilitations in the four independently recorded flexor muscles and a postspike facilitation in the FDP muscle. Early features usually had substantially larger MPis than superimposed postspike effects, as in Fig. 8.

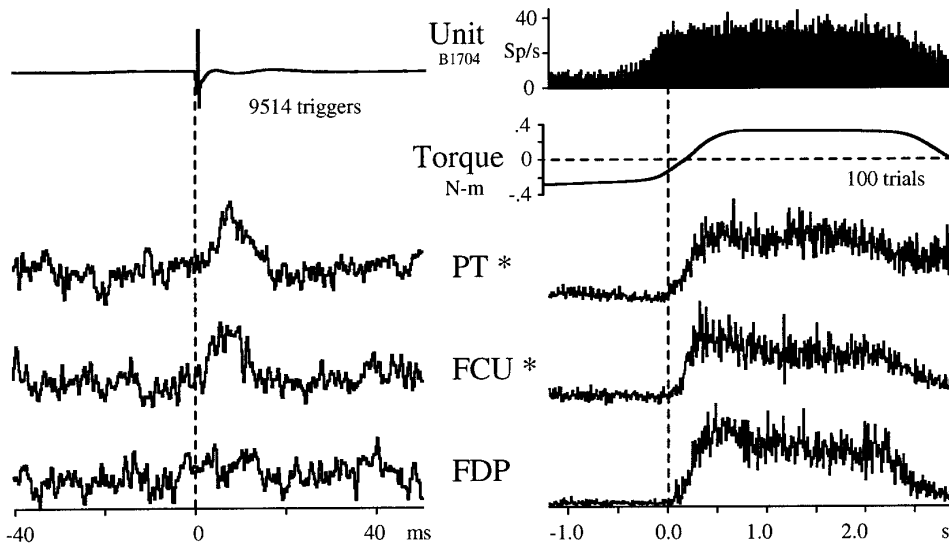

FIG. 5. STAs and response averages of a facilitatory premotor interneuron (PreM-IN) located in lamina VII of caudal C₈. Data were collected during the alternating task. *Left*: triggering action potential above the STAs of EMG in 3 independently recorded coactive muscles. *Muscles with significant postspike effects. STAs are plotted with the variances in baseline activity normalized to the STA of the muscle with the largest postspike effect (PT). *Right*: average activity of the neuron during flexion torques above the average torque trajectory (positive torque in flexion, negative torque in extension) and average responses of the coactive muscles. Neuron exhibited tonic firing during static torques, at a higher rate for flexion. Respective data for PT and flexor carpi ulnaris (FCU): mean percent increase (MPI), 5.0 and 3.9%; peak percent increase (PPI), 9.9 and 5.9%; onset latency, 3.6 and 3.5 ms; peak latency, 8.1 and 5.9 ms; duration of postspike facilitation, 13.0 and 9.3 ms.

The vast majority of postspike effects observed were facilitatory (Fig. 9). Eighty-two of 100 PreM-INS generated only postspike facilitations in one or more muscles, whereas 14 elicited only postspike suppressions. Four PreM-INS had effects of opposite polarity in flexor and extensor muscles. Of 161 postspike effects for the entire population of PreM-INS, 24 (15%) were inhibitory.

Distribution of postspike effects in muscles

Postspike effects were present in only one of the coactivated muscles for 64 of the 100 PreM-INS (e.g., Figs. 6 and 8). The other PreM-INS had larger “muscle fields”: 22 had postspike effects in 2 muscles (e.g., Fig. 5) and 14 produced effects in ≥3 muscles. Most PreM-INS with multiple target muscles (25/36) produced postspike effects only in coactive muscles (i.e., the 5 primary flexor muscles plus PT during flexion torques or the 5 primary extensor muscles plus APL

during extension torques). The other PreM-INS cofacilitated (Fig. 10), cosuppressed, or produced reciprocal effects in flexor and extensor muscles. A larger proportion of neurons classified as last-order interneurons (5/18, 28%) had postspike effects in both flexor and extensor muscles than other PreM-INS (6/82, 7%).

The divergence of a PreM-INS output effects was quantified by dividing the number of muscles with postspike effects by the number of independent, coactivated muscles that were recorded simultaneously. This ratio had a mean of 33% for PreM-INS; ratios were similar for neurons that facilitated or suppressed target muscles.

Postspike effects were twice as common in flexor as in extensor muscles (Fig. 9). Of the 100 PreM-INS, 58 had postspike effects in flexor muscles only (including APL), whereas 29 had effects in extensor muscles only (including APL), 11 had effects in flexors and extensors, and 2 had effects in BR. Of the 161 postspike effects for all PreM-

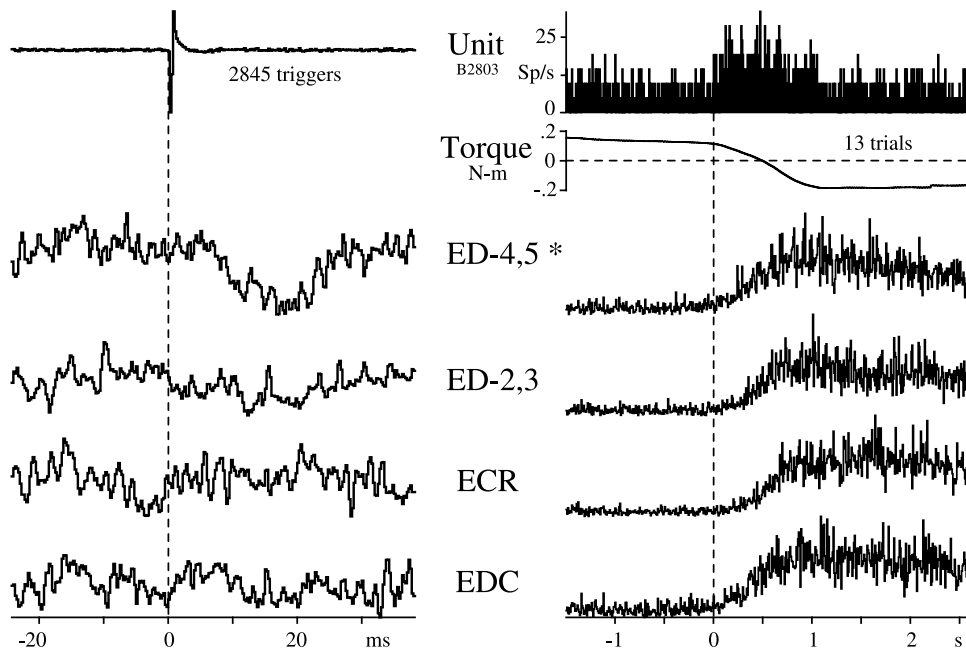

FIG. 6. STAs and response averages of an inhibitory PreM-IN in rostral T₁; format as in Fig. 5. Cell fired phasically during extension torques and produced a postspike suppression in the extensor digitorum-4,5 (ED-4,5) muscle. mean percent decrease (MPD), -8.5%; peak percent decrease (PPD), -12.0%; onset latency, 9.3 ms; peak latency, 16.8 ms; duration of postspike suppression, 13.5 ms. Note that on average postspike facilitations and suppressions had similar rise times (Table 1), despite the difference between the effect in this figure and those in Fig. 5.

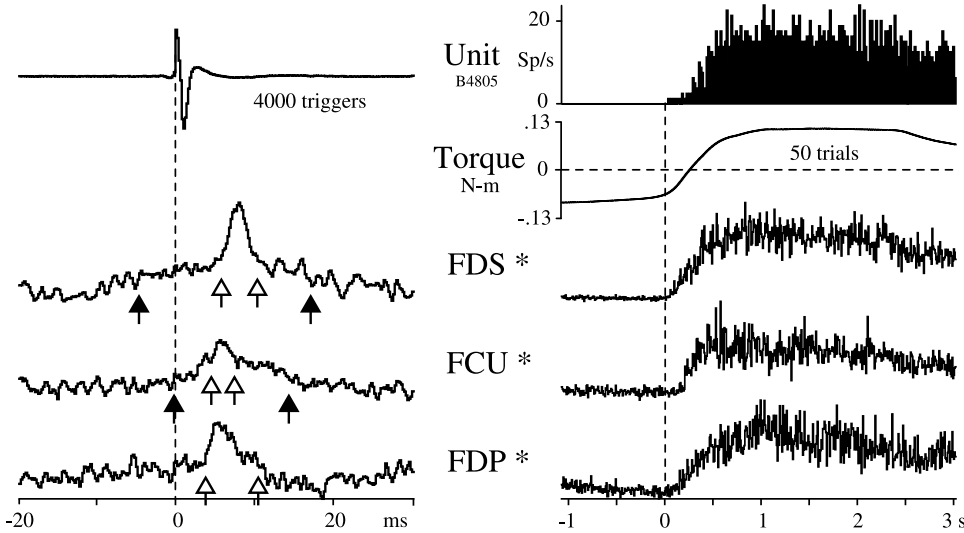

FIG. 7. STAs and response average of a PreM-IN in lamina VII of the C₈–T₁ border; format as in Fig. 5. Postspike facilitations (Δ) were superimposed on synchrony facilitations (\blacktriangle) in the flexor digitorum superficialis (FDS) and FCU muscles. “Peak” immediately preceding the postspike facilitation in FCU was not present in repeated STAs compiled with independent triggers and was regarded as baseline noise. Neuron was activated tonically during flexion torques and was silent during extension. MPI and PPI of postspike effects are 5.4 and 10.9% in FDS, 3.4 and 5.5% in FCU, and 7.6 and 14.2% in flexor digitorum profundus (FDP). MPI and PPI of synchrony effects are 5.4 and 7.4% in FDS and 5.4 and 8.7% in FCU.

INs, 101 (63%) were in flexor muscles. This proportion was similar for postspike facilitation and suppression (Table 1 and Fig. 9).

There was a slight tendency for postspike effects to occur more often in muscles with primary action on the fingers. For the flexor muscles, the number of effects ranged from 15 in FCR to 21 in FDS; only 7 effects were seen in PT. The number of postspike effects observed in ED-2,3 ($n = 18$) was higher than in the other extensor muscles, which ranged from 5 effects in APL to 11 in EDC.

Parameters of postspike effects

Postspike effects had a wide distribution of onset times, with a mean latency of 7.4 ± 3.5 (SD) ms (Fig. 11A). Facilitatory and suppressive effects had similar onsets for neurons classified as last-order interneurons, but postspike facilitations tended to have earlier onsets than postspike

suppressions for other PreM-INs (Table 1). Seventy-nine percent of all postspike effects peaked within 3.5 ms of onset and had durations of <8.0 ms (Fig. 11, E and F). Some effects lasted >10 ms, and in a few cases, the STAs showed two clear peaks in the averaged EMG. Postspike features with long durations may reflect PreM-IN connections to fast and slow motor units or the combined effects of mono- and oligosynaptic connections to motoneurons. Neurons classified as last-order interneurons exhibited postspike effects with longer durations in flexor muscles (but not in extensor muscles) and longer rise times than other PreM-INs. There were no other significant differences in the timing of postspike effects in flexor and extensor muscles (Table 1).

The magnitudes of postspike facilitations (mean MPI = 4.6%) and suppressions (mean MPD = -4.2%) were similar, as were the peak percent changes (Table 1). There was no significant difference between the magnitudes of

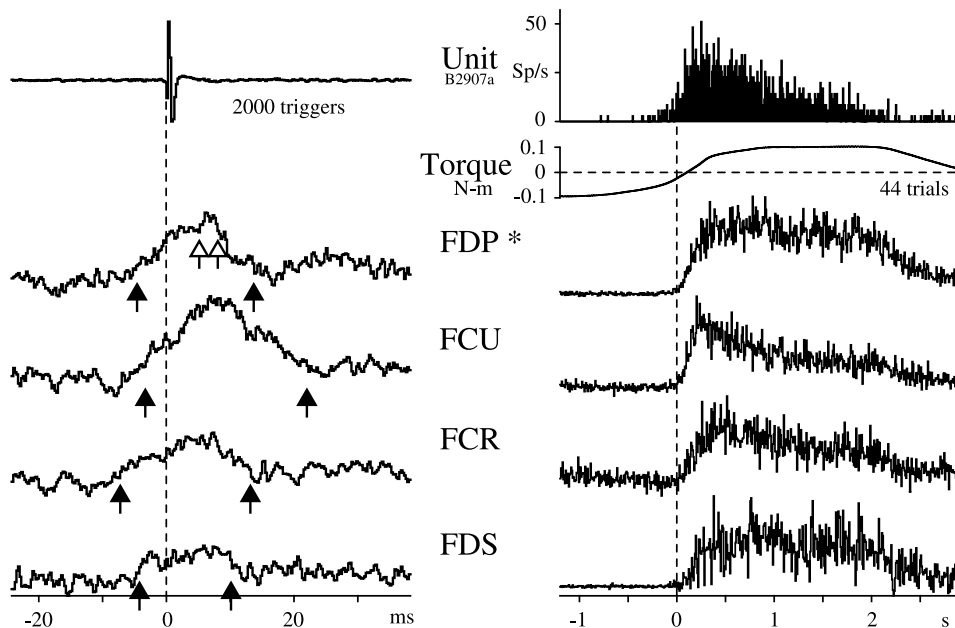

FIG. 8. STAs and response average of a PreM-IN located near the motor nuclei in T₁; format as in Fig. 5. STA shows a postspike facilitation (Δ) superimposed on a synchrony facilitation (\blacktriangle) in FDP and pure synchrony facilitations in the other 4 independently recorded flexor muscles. Neuron was activated for flexion torques with a decrementing response pattern. MPI and PPI of postspike effect are 4.7 and 7.7% in FDP. MPI and PPI of synchrony effects are 14.0 and 21.4% in FDP, 18.7 and 33.0% in FCU, 12.3 and 20.8% in flexor carpi radialis (FCR), and 6.5 and 9.3% in FDS.

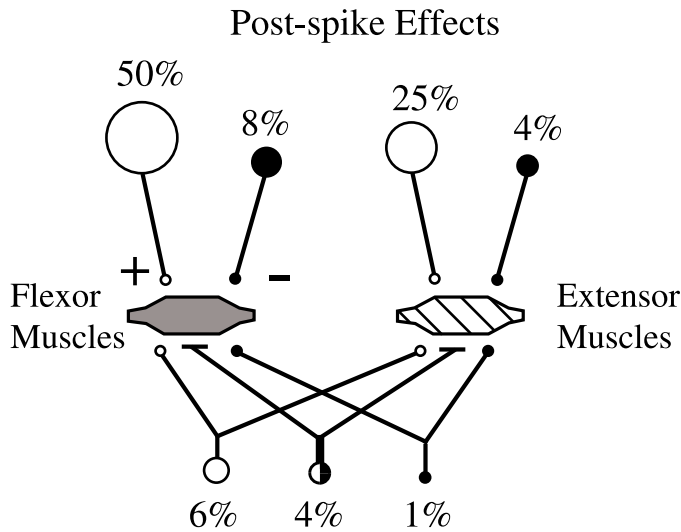

FIG. 9. Relative distributions of postspike effects to wrist flexor and extensor muscles for 98 PreM-INs. ○, neurons producing postspike facilitations; ●, neurons producing postspike suppressions. Neurons with reciprocal postspike effects (●) included 2 that facilitated flexors and suppressed extensors and 2 that facilitated extensors and suppressed flexors. Two neurons with postspike effects only in brachioradialis muscle are not included. Percentages of total number of premotor neurons are listed and depicted as relative area of associated balloon.

postspike effects in flexor and extensor muscles (Table 1) or among effects in the three monkeys.

Response averages and relation to output effects

PreM-INs exhibited various firing patterns during the generation of isometric flexion/extension torques, including tonic (Figs. 5 and 7), phasic (Fig. 6), phasic-tonic (Fig.

10), and decrementing (Fig. 8) responses. Neuronal firing properties are discussed in detail in the companion paper (Maier et al. 1998), but a brief description is relevant here to compare response patterns with the output effects of PreM-INs. Two features of each neuron's firing properties are considered: the cell's "preferred" direction and its activity during torques in the opposite direction.

The discharge rate of 92 PreM-INs increased during torque production in one or both directions. The preferred direction for these cells was taken as the direction of torque for which the neuron's firing rate increased the most. Five other PreM-INs exhibited only a decrease in firing rate associated with one direction of torque, either phasically in the alternating task or tonically relative to the activity during zero torque in the center-out task. For these cells, torque in the direction opposite to that in which the firing rate decreased was considered the preferred direction. Finally three PreM-INs exhibited an unmodulated, steady discharge rate that was not related to flexion/extension torque generated at the wrist. No preferred direction could be assigned to these neurons. A neuron's agonist and antagonist muscles were defined as those muscles that were active for torques in the neuron's preferred and nonpreferred directions, respectively.

Twenty-six (26%) PreM-INs were silent when the monkey produced torque in the direction opposite to their preferred direction (e.g., Fig. 1A), whereas 74 were active for both directions of torque. Of these 74 cells, 37 exhibited increases in activity for both flexion and extension (e.g., Fig. 10), 34 fired tonically when torque was produced in the direction opposite to its preferred direction (e.g., Fig. 1B), and 3 cells had unmodulated activity. For *monkey W*, most neurons that were active for both directions of torque also discharged when the monkey exerted no torque while holding the cursor within the center target.

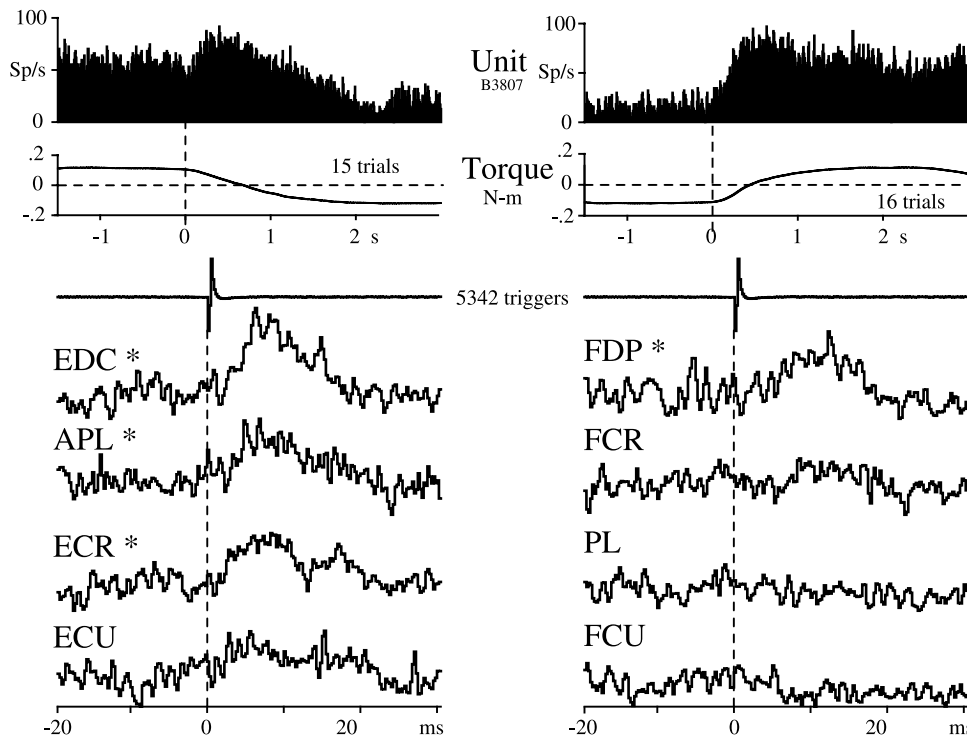

FIG. 10. STAs and response averages of a lamina VII neuron in C₈ that cofacilitated extensor and flexor muscles; format as in Fig. 5. Neuron had tonic background firing for maintained torques, with discharge rate higher for flexion than extension torques, and a phasic increase in rate at the onset of torques in either direction. Postspike facilitation was produced in extensor digitorum communis (EDC), abductor pollicis longus (APL), extensor carpi radialis (ECR), and FDP. First peak in ECR is a posttrigger early effect (latency 2.6 ms). MPI and PPI of effects are 8.7 and 14.0% in EDC, 2.5 and 3.9% in APL, 3.5 and 5.5% in ECR, and 4.7 and 9.0% in FDP.

TABLE 1. *Parameters of output effects*

	Postspike Facilitation			Postspike Suppression			Early Facilitation			Early Suppression		
	Flexors	Extensors	Total	Flexors	Extensors	Total	Flexors	Extensors	Total	Flexors	Extensors	Total
Number	86	50	137*	15	8	24*	60	26	87†	18	29	51†
MPI or MPD, %	4.9	4.3	4.6 ± 2.0	-4.1	-4.6	-4.2 ± 1.9	7.9	5.1	7.1 ± 4.0	-5.2	-5.4	-5.2 ± 2.4
PPI or PPD, %	8.0	7.2	7.7 ± 3.3	-6.1	-7.2	-6.4 ± 2.6	13.0	8.3	11.6 ± 7.1	-9.1	-9.0	-8.8 ± 4.4
Onset latency, ms	7.1	7.6	7.3 ± 3.3	8.8	8.2	8.5 ± 4.4	-3.7	-5.3	-4.1 ± 8.2	-9.6	-8.7	-9.4 ± 7.4
Peak time, ms	9.1	9.9	9.3 ± 3.7	10.7	11.2	10.8 ± 4.5	2.8	-2.1	1.4 ± 8.0	-4.4	-4.1	-4.7 ± 6.8
Duration, ms	5.3	5.8	5.5 ± 3.2	3.7	5.9	4.6 ± 3.1	14.5	9.8	13.1 ± 7.0	10.4	9.8	9.6 ± 4.5
Rise time, ms	2.0	2.4	2.1 ± 1.8	1.9	3.0	2.3 ± 1.9	7.3	4.6	6.4 ± 4.4	5.3	4.5	4.7 ± 2.9

Values are ± SD. * Includes one additional postspike facilitation and one postspike suppression in brachioradialis. † Includes one additional early facilitation and four early suppressions in brachioradialis. MPI and MPD, mean percent increase and decrease; PPI and PPD, peak percent increase and decrease.

The relation between a PreM-IN's activity pattern and the postspike effects it produces in target muscles (Fig. 12) delimits the neuron's possible functions. Motoneurons innervating primary flexor and extensor muscles fired in a strictly reciprocal pattern during the task: they were activated

for torques in one direction and completely silent for torques in the opposite direction. Excitatory inputs from PreM-INs with similar activity patterns are suitable for directly driving motoneuron output. Twenty-four PreM-INs had firing patterns and output effects that matched these criteria (open

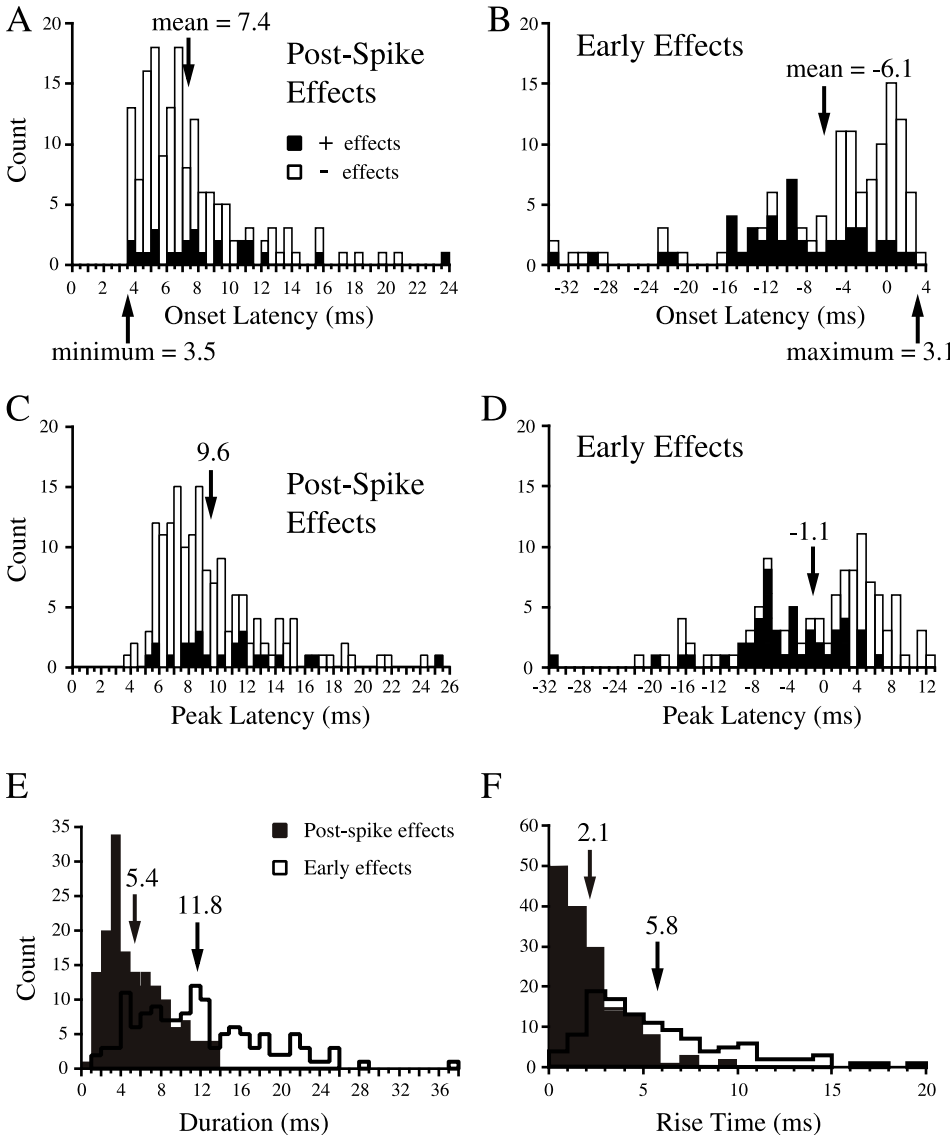

FIG. 11. Timing of spike-related effects in forearm muscles. Histograms show onset latency (A and B) and peak latency (C and D) for postspike (left) and early effects (right). □, facilitatory effects; ■, suppressive effects. Histogram outlines show duration (E) and rise time (F) of postspike (■) and early (□) effects. ↓, means (milliseconds) for all effects.

Post-spike Effects

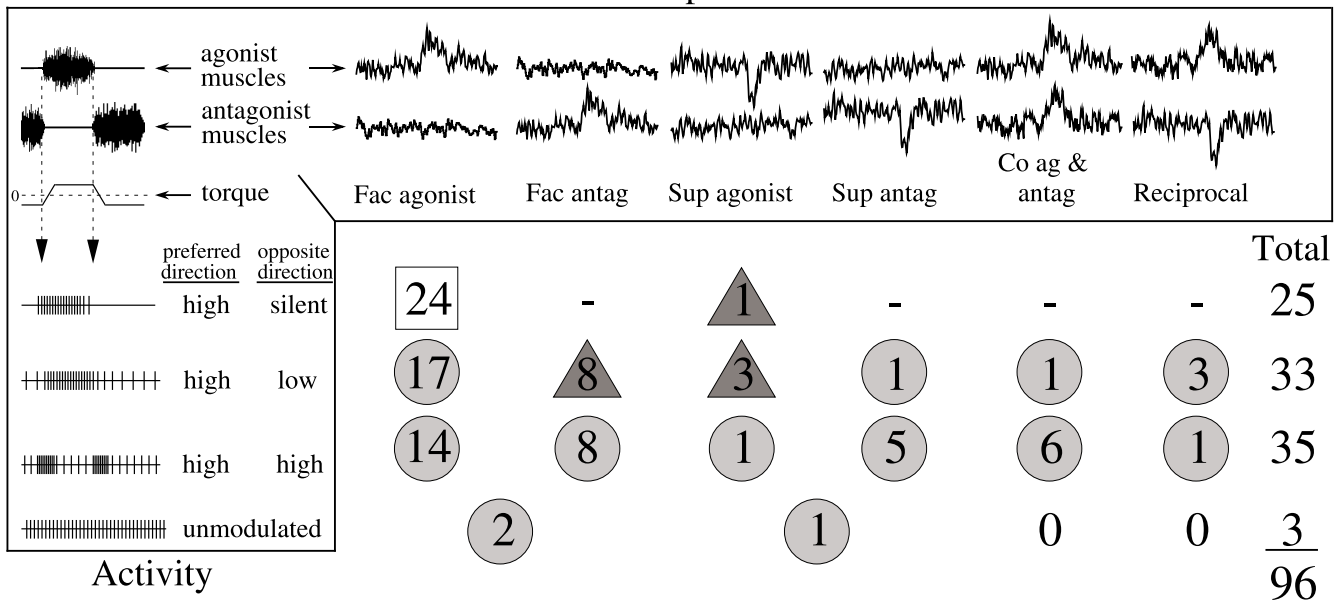

FIG. 12. Relation between response patterns and postspike effects of PreM-INS. Neuron's agonist muscles are those active in the direction of torque for which the neuron has the largest increase in activity (not defined for neurons with unmodulated activity, 50 entries not aligned with agonist or antagonist columns). Fac, facilitatory effects; Sup, suppressive effects; dashed lines indicate connections that are not detectable by spike-triggered averaging. Two PreM-INS with postspike effects in brachioradialis (BR) are not included; 2 PreM-INS with postspike effects only in PT during trials in which PT was bidirectionally active are also not included. Square, circles, and triangles indicate increasing incongruity between response pattern and postspike effects (see text for details).

box in Fig. 12). An example of this type of PreM-IN is shown in Fig. 7. This neuron discharged during flexion torques, was silent during extension, and produced postspike facilitations in coactive flexor muscles.

An additional 60 PreM-INS were activated for directions of torque that were consistent with their output effects but had additional response components that cannot be explained by a strictly reciprocal control of flexion/extension movements (shaded circles in Fig. 12). For example, although the preferred direction of many facilitatory PreM-INS was the same as the "on" direction of the facilitated muscles, these neurons, unlike their target muscles, were not silent for the opposite direction of torque. This category includes PreM-INS that cofacilitated, cosuppressed, or had reciprocal effects on flexor and extensor muscles. The postspike effects produced by these neurons contributed to the activation of agonist muscles or the inhibition of antagonist muscles for one direction of torque but provided inputs to motoneurons that were incongruent with their target muscles' activity during the opposite direction of torque (e.g., Fig. 10).

Finally, 12 neurons had seemingly paradoxical activity patterns in light of their postspike effects (dark triangles in Fig. 12). For example, four neurons had slow background activity during flexion torques and increased firing rates during extension torques, yet produced postspike facilitations in primary flexor muscles. None of these 12 neurons were classified as last-order interneurons; all last-order interneurons had activity that was congruent with the cell's postspike effects for at least one direction of torque.

Location of PreM-INS

Recordings were made primarily in C₈-T₁ in *monkey B*, in caudal C₇-C₈ in *monkey R*, and in C₆-C₇ in *monkey W*. The approximate position of PreM-INS in the transverse plane of the spinal cord was estimated for *monkeys B* and *W* (Fig. 13), in which iron deposits were recovered in histological sections. Each cell's mediolateral position was determined by the relation of the recording track to the lesion tracks. We could not reliably estimate the dorsoventral position of neurons on the basis of these lesions because we did not have a consistent dorsoventral reference from track to track. Instead, we estimated the depth of the neuron by mapping its position relative to the depth of the first and last clearly recorded somatic activity within the track onto the outline of the gray matter at the appropriate mediolateral coordinate.

Most PreM-INS were located in the intermediate laminae of the ventral horn (Fig. 13). A few PreM-INS were found in the dorsal horn, although it is possible that our mapping procedure underestimated their depth in the cord. There was no clear relation between the output properties of PreM-INS and their location. Neurons classified as last-order interneurons were not localized to specific regions of the gray matter.

Spike-related effects with early onsets

TIMING. The STAs of 72 neurons exhibited spike-related effects with onset latencies of <3.5 ms. A total of 138 early effects were seen.

Early effects were subdivided into three groups on the

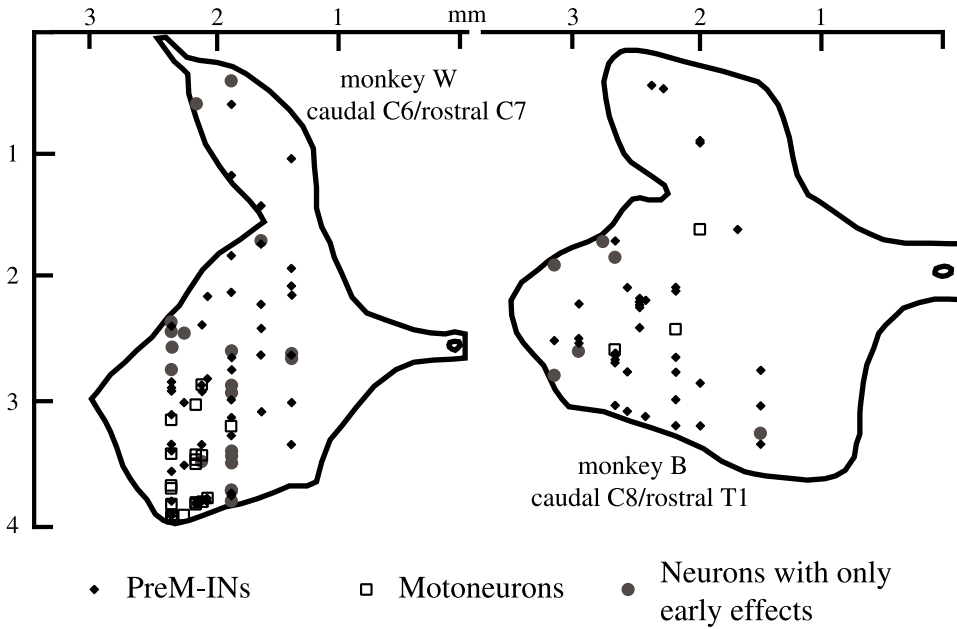

FIG. 13. Histological reconstruction of recording sites for neurons in *monkeys B and W*. Sites are collapsed onto 1 frontal section of the gray matter in each monkey. ♦, PreM-INs; □, putative motoneurons; ○, neurons with spike-related early effects in STAs (and no postspike effects). See text for details of reconstruction method. One motoneuron appears to be located in lamina VI or VII, which probably reflects a limitation of this procedure.

basis of their timing relative to the trigger spike (Fig. 14). Synchrony effects (○, 59%, 81 effects for 45 neurons) straddled the trigger time, having onsets before and offsets after the trigger (Figs. 7, 8, and 15, *A and B*). Early-posttrigger effects (●, 19%, 27 effects for 24 neurons) had onsets that occurred after the trigger but were too early (<3.5 ms) to be classified as postspike effects. Pretrigger effects (◐, 22%, 30 effects for 22 neurons) began and ended entirely before the occurrence of the triggering action potential. A few large, consistent pretrigger effects had onset latencies of less than -20 ms (Fig. 15, *E and F*).

Thirty-eight of the neurons exhibiting early effects in

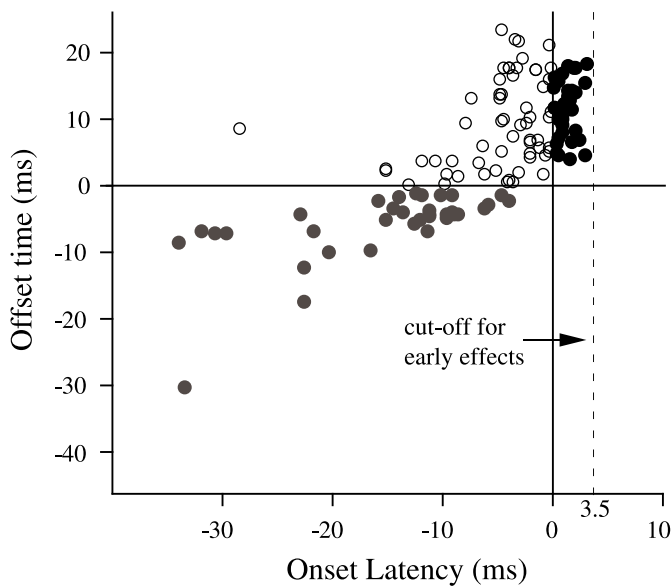

FIG. 14. Onset times plotted against offset times for all early effects. Effects that straddle the trigger time are classified as synchrony effects (○); effects entirely after the trigger are classified as early-posttrigger effects (●); effects entirely before the trigger are classified as pretrigger effects (◐).

STAs were PreM-INs, with postspike and earlier effects in the same or different muscles. Postspike effects often were superimposed on either synchrony or early-posttrigger effects in individual muscles (Figs. 7 and 8). The remaining 34 neurons associated with early effects had no identifiable postspike effect in any recorded muscle.

Although most early effects were purely facilitatory or suppressive (Figs. 7, 8, and 15, *A and B*), the STAs of 14 neurons exhibited multiphasic early effects. In all cases, a phase of suppression was followed immediately by a phase of facilitation (Fig. 15*C*), with the transition usually occurring within a few milliseconds of the trigger time. In a few cases, two or more cycles of suppression followed by facilitation were repeated (Fig. 15*D*), suggesting an oscillatory pattern in the EMG. In such cases peaks in average EMG recurred with periodic frequencies of 25–45 Hz. None of the neurons associated with multiphasic early effects had periodic autocorrelation peaks.

It has been suggested that troughs preceding postspike facilitations in STAs of EMG can be due to the interspike intervals of the triggering neuron (Lemon and Mantel 1989; McKiernan and Cheney 1993). We recompiled STAs with biphasic effects straddling the trigger time using only triggers preceded by a long interspike interval (30–50 ms). If the initial suppression of EMG was related to a trough in the neuron's autocorrelation (Fig. 15, *insets*), this procedure would increase the duration of the suppressive phase. However, there was no significant change in the shape or duration of the effects.

PARAMETERS AND DISTRIBUTION. Early spike-related effects had, on average, slower rise times, longer durations (Fig. 11, *E and F*), and larger magnitudes than postspike effects ($P < 0.01$; Table 1). The rise times of early-posttrigger effects (mean = 4.1 ms) tended to be shorter than those of synchrony effects (mean = 6.5 ms) but longer than those of postspike effects (2.1 ms).

Early facilitatory effects tended to be significantly ($P < 0.05$) larger and longer in duration and had later onsets than early

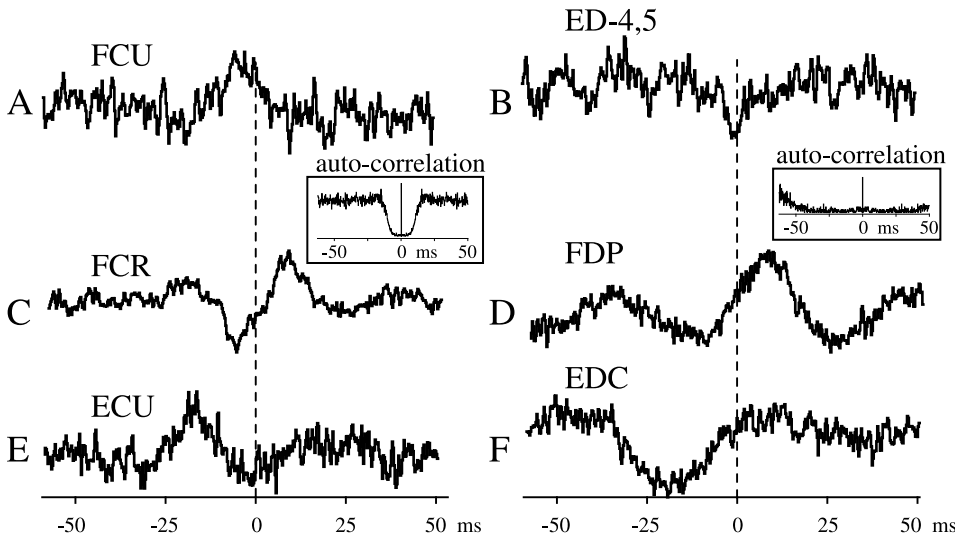

FIG. 15. Examples of different types of early effects from 6 different spinal interneurons. *A* and *B*: facilitatory and suppressive synchrony effects, respectively, associated with neurons that had no observable postspike effect in any muscle. *C* and *D*: multiphasic effects; *insets*: autocorrelogram of trigger cell. *E* and *F*: entirely pretrigger facilitation and suppression of EMG, respectively.

suppressing effects (Table 1). In addition, the average early effect in flexor muscles had a larger MPI, peaked later, and lasted longer than the average effect in extensors ($P < 0.05$).

Early effects had a similar distribution to flexor and extensor muscles and affected roughly the same proportions of muscles as postspike effects (Fig. 16). The majority of early effects were facilitatory (Table 1) and appeared in flexor muscles, although the proportion in extensors was slightly higher than for postspike effects. Early effects were not preferentially distributed to any of the primary flexor or extensor muscles, although the carpi radialis muscles had a higher incidence of multiphasic effects than other muscles.

DISCUSSION

Our goals in this study were to provide the first direct information on two functionally significant properties of spi-

nal interneurons: their effects on muscle activation and their activity patterns during normal voluntary movements. In this paper, we focused on the first objective by characterizing the effects of individual PreM-INs on the firing probability of forearm muscles. In the companion paper, we addressed the second issue in more detail. Here, we compare our results on the postspike effects of spinal interneurons with previous data from supraspinal and afferent premotor neurons obtained under similar conditions and with data from spinal interneurons obtained in anesthetized or decerebrate animals. Then we discuss the implications of these results for the control of motoneuron activity during voluntary wrist movements. Before addressing these issues, we consider the synaptic linkages that produce the postspike effects.

Synaptic pathways mediating postspike effects

By our estimate, the shortest possible latency of STA features that could be mediated by monosynaptic connections of spinal interneurons to fast conducting motor units is 3.5 ms. This estimate is based on the latency of stimulus-evoked effects (Fig. 4) and is consistent with available data on the timing of synaptic transmission and spike initiation in motoneurons (Gustaffson and Jankowska 1976; Jankowska and Roberts 1972), motor axon conduction velocities in monkeys (≤ 90 m/s) (Carp 1992; Eccles et al. 1968; Gilliatt et al. 1976), and the estimated length of forearm motor axons (20–35 cm) in the three monkeys of this study.

Last-order interneurons can produce effects in STAs of EMG with much larger latencies for several reasons. Interneuron axons with slower conduction velocities (as low as 20 m/s for stem axons) (Jankowska 1992) and longer conduction distances (C_7-T_1 motoneurons extend over ~ 2.5 cm in macaques) (Jenny and Inukai 1983) can account for delays of several milliseconds. Even more importantly, the size of the affected motoneurons determines the conduction time along the motor axon, which is a significant component of the onset latency of postspike effects. Many large, fast-conducting motoneurons may not be activated at the low force levels used in these experiments. Differences in conduction velocities of slow- and fast-twitch motoneurons (40–90 m/s in monkeys) (Carp 1992; Eccles et al. 1968;

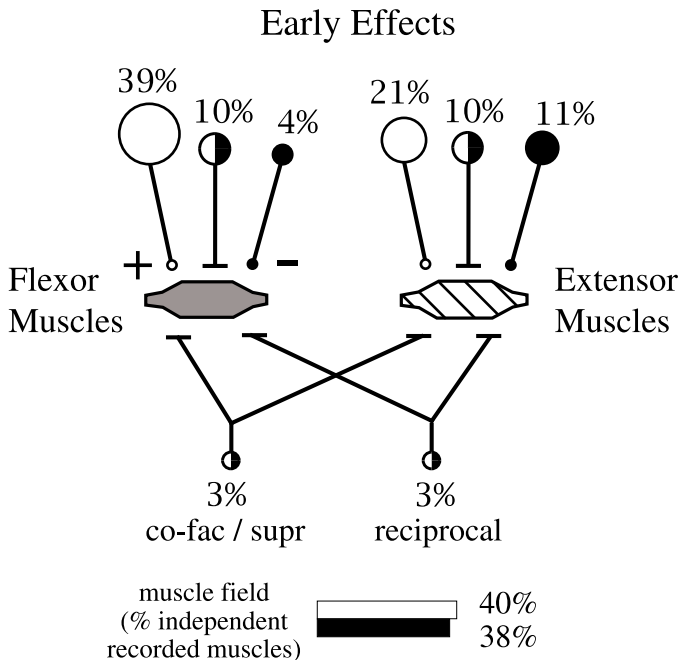

FIG. 16. Relative distributions of early effects to flexor and extensor muscles; format as in Fig. 9.

Gilliatt et al. 1976) can contribute differences in onset delays of ~5 ms (for motor axons 35 cm long) for postspike effects produced by PreM-INs projecting selectively to small versus large motoneurons (Garnett and Stephens 1980; Heckman and Binder 1988). Thus postspike effects that begin ≤ 10 ms after the trigger time still could be mediated by monosynaptic connections to motoneurons (Kasser and Cheney 1985).

Some postspike effects, particularly those with onset latencies of > 10 ms, were probably mediated by oligosynaptic pathways. STAs of EMG have revealed inhibitory linkages from motor cortical (Kasser and Cheney 1985) and rubral (Mewes and Cheney 1991) neurons and excitatory linkages from thalamic neurons (Mewes and Cheney 1990) to forearm muscles. These effects are at least disynaptically mediated. Short onset latencies can result from disynaptic pathways with short conduction distances to fast-conducting motoneurons. We estimated that postspike effects in EMG with latencies of ≥ 4.5 ms could be mediated by disynaptic pathways.

Given the extensive overlap between the possible onset times of postspike effects mediated by mono- and disynaptic connections to motoneurons, we used a stringent criterion to classify last-order interneurons. Other PreM-INs had potentially oligosynaptic linkages to motoneurons, but most of them probably exerted influences on motoneuron firing through slower monosynaptic pathways.

Distribution of postspike effects in muscles

The majority of PreM-INs had postspike effects in only one target muscle. This was somewhat surprising in light of previous data from spinal interneurons and other premotor neurons.

Intracellular staining and electrophysiological mapping of a few types of last-order interneurons have revealed widespread branching of axon collaterals and postsynaptic potentials produced in motoneurons of more than one muscle in the lumbosacral (Cavallari et al. 1987; Czarkowska et al. 1981; Jankowska and Roberts 1972) and cervical (Hongo et al. 1989) cord of cats. This may represent a difference in the organization of primate cervical and feline lumbar spinal circuits or may be due to our sampling of different species of interneurons. Alternatively, interneurons with widespread axonal branching may produce postspike effects in only one muscle for several possible reasons. Some anatomic connections may produce postsynaptic potentials that are too small to produce postspike effects that rise above the background EMG level (Cope et al. 1987) or are in motor units that are not sampled by the EMG electrodes. It is also possible that presynaptic inhibition of interneuron terminals (Aggelopoulos et al. 1997) during normal behavior (Hultborn et al. 1987) decreases the effectiveness of the synapses from specific axonal branches. Finally the interneurons could have branches to large motoneurons that were inactive for the task used in this study.

Premotor neurons in motor cortex (CM cells) (Fetz and Cheney 1980; Kasser and Cheney 1985), red nucleus (RM cells) (Mewes and Cheney 1991), and C_8 - T_1 dorsal root ganglia (DRG cells) (Flament et al. 1992) have more divergent facilitatory outputs than PreM-INs (Fig. 17). Excitatory

spinal PreM-INs may have more focused effects on motor pools than supraspinal cells and segmental afferents and thus may exert more fractionated control of muscles than do CM, RM, and DRG cells.

One technical issue must be considered in these comparisons with previous STA studies. Synchrony effects were less obvious for CM and RM cells and therefore were not distinguished as carefully from postspike effects (Fetz and Cheney 1980; Kasser and Cheney 1985; Mewes and Cheney 1991). Comparing the latency of the postspike effects with poststimulus effects elicited by single microstimuli in the cortex or red nucleus (Cheney and Fetz 1985; Mewes and Cheney 1991) suggests that the short-latency STA features of CM and RM cells did include synchrony effects. Consequently, the muscle field sizes of CM and RM cells may have been overestimated by inclusion of muscles for which STAs exhibited purely synchrony effects. Synchrony and postspike effects were differentiated for DRG afferents (Flament et al. 1992), so their muscle fields and those of PreM-INs are directly comparable.

The distribution of postspike effects from PreM-INs to flexor and extensor muscles also differed from the output patterns of the other premotor populations (Fig. 17). PreM-INs influenced the activity of flexor muscles twice as often as extensor muscles, although the magnitudes of the effects were similar. CM (Fetz and Cheney 1980; Kasser and Cheney 1985) and DRG (Flament et al. 1992) cells generated postspike effects equally in flexor and extensor muscles, and RM cells generated effects more often in extensor muscles than in flexors (Belhaj-Saif et al. 1998; Mewes and Cheney 1991). In addition, the magnitude of postspike effects produced by CM cells was greater in extensor muscles than in flexors (Fetz and Cheney 1980). It is possible that the preferential distribution of postspike effects to flexor muscles reflects a sampling bias of our interneuron recordings. For example, forearm flexor muscle motoneurons are located more rostrally than extensor motoneurons in the cervical enlargement (Jenny and Inukai 1983). However, the rostrocaudal distribution of PreM-INs with effects on flexor versus extensor muscles showed no clear difference.

Alternatively, extensor muscles may be controlled more directly by supraspinal inputs and flexor muscles more directly by spinal interneurons. Differential control of specific muscle groups is typical of many premotor pathways (Buys et al. 1986; Cangiano and Lutzemberger 1972; Clough et al. 1968; Wilson and Peterson 1981). The preferential linkages of PreM-INs to small numbers of forearm flexors may reflect a greater involvement of spinal processing in the control of individual muscles or small groups of muscles during diverse grasping movements of the hand and less influence over more stereotyped hand opening and wrist extension movements.

The flexor bias of PreM-INs recalls the original formulation of the "flexor reflex afferent" system (Eccles and Lundberg 1959; Sherrington 1910), and many PreM-INs with facilitatory postspike effects in flexor muscles may be interneurons mediating flexion reflexes. The widespread flexion reflexes elicited by activation of diverse afferent pathways in spinalized animals suggest that spinal interneurons exert more control on flexor than extensor motoneurons. However, it is clear that the interneurons that mediate flexion reflexes

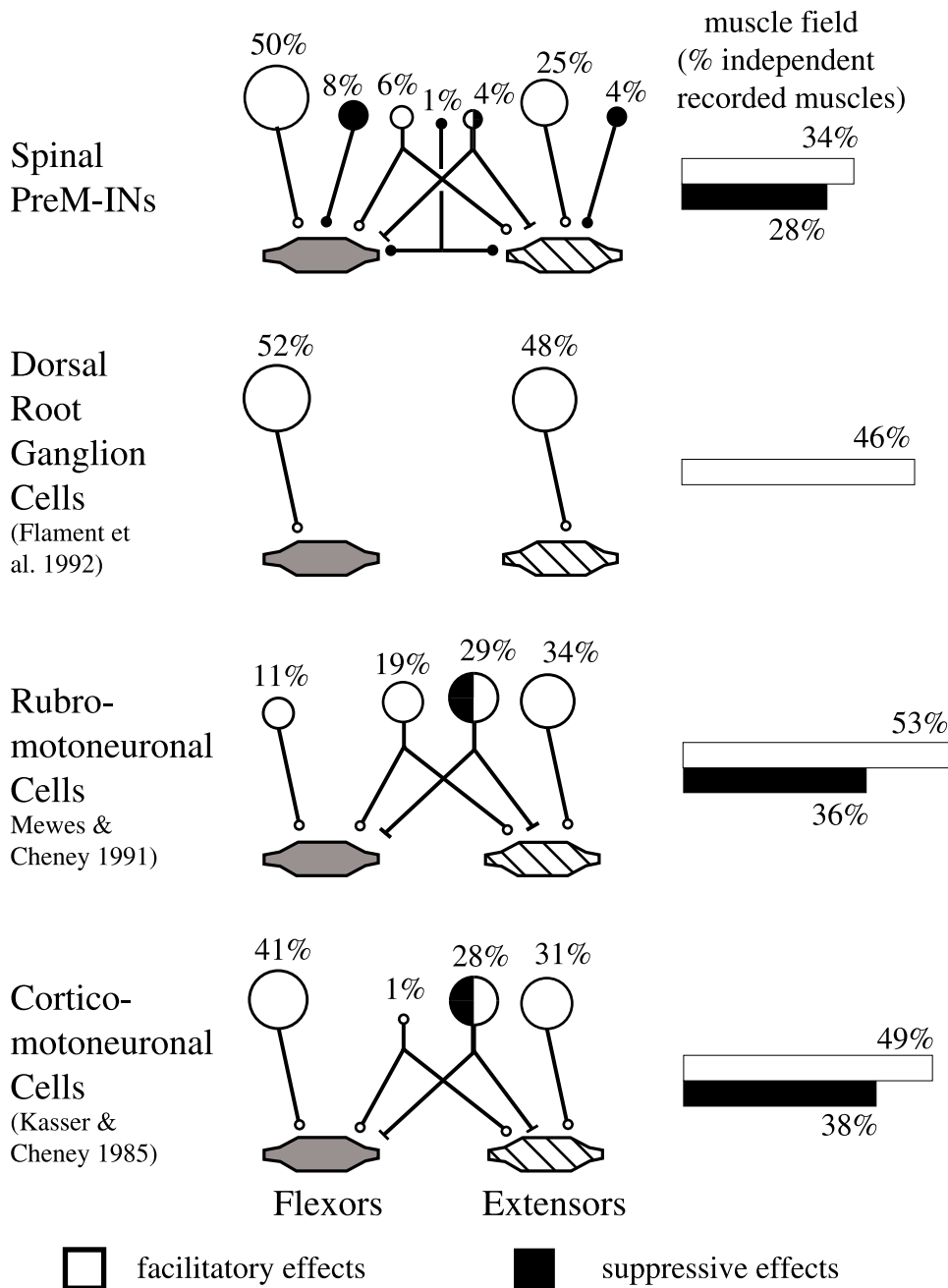

FIG. 17. Relative distributions of postspike effects to flexor and extensor muscles for PreM-INs (same as Fig. 9) and premotor populations previously studied in the motor cortex, red nucleus, and dorsal root ganglia under similar behavioral conditions. Percentages of total number of premotor neurons are listed and depicted as relative area of associated balloon. Relative size of average muscle fields for postspike facilitations and postspike suppressions (considered separately, even when produced by individual neurons with reciprocal output effects) as a percentage of the number of independent, coactive muscles are shown (right) for each population.

are used for a variety of other movements under different behavioral conditions (Lundberg et al. 1987; McCrea 1992). Because the monkeys in our study produced extension torques as often as flexion torques, it appears that interneurons in the primate cervical spinal cord are organized preferentially to influence the activity of flexor motoneurons.

The different distributions of postspike effects for PreM-INs and other premotor cells appear to be independent of the size of the effects. Facilitatory PreM-INs produced postspike effects that were comparable in magnitude with those of CM (Fetz and Cheney 1980; Kasser and Cheney 1985) and DRG (Flament et al. 1992) neurons and only slightly larger than those of RM cells (Mewes and Cheney 1991). On the other hand, postspike suppressions produced by spinal PreM-INs had a shorter mean latency and a larger mean amplitude than

those produced by CM (Kasser and Cheney 1985) and RM cells (Mewes and Cheney 1991). This suggests that suppressive PreM-INs were probably last-order inhibitory interneurons.

Activity patterns of Prem-INs

The discharge patterns of spinal interneurons during isometric torque production at the wrist share many features with those of motoneurons of primary wrist flexor and extensor muscles (Maier et al. 1998). However, motoneurons discharge only when the monkey produces torque in one direction. In contrast, 74% of PreM-INs (71% of neurons classified as last-order interneurons) maintained at least some background activity during torques in both directions

and thus are not organized into simple, reciprocally firing pathways.

Bidirectional increases in discharge rate or residual activity during arm or finger movements in the nonpreferred direction are common for rubrospinal neurons (Gibson et al. 1985; Mewes and Cheney 1994), uncommon for DRG cells and motor cortical neurons during single joint movements (Crutcher and Alexander 1990; Evarts 1968; Flament et al. 1992; Murphy et al. 1982; Thach 1978), and virtually absent for CM cells projecting to forearm muscles (Cheney and Fetz 1980). In their study on hand movements, Gibson et al. (1985) found that magnocellular red nucleus neurons had little resting discharge when monkeys were not making active muscle contractions. Similarly Mewes and Cheney (1994) reported that the background activity of RM cells decreased substantially when the monkeys were not actively engaged in the task. We occasionally observed that spinal interneurons with activity during zero or nonpreferred torques had significantly decreased discharge rates during "time outs" when the target displays were turned off and the monkey was distracted from the task. In the flexion/extension task, the activity of PreM-INs for zero and nonpreferred torques and of RM cells for nonpreferred torques (Mewes and Cheney 1994) may represent a generalized increased excitability related to the generation of movement. Apparently this increased excitability was not evoked by the behavioral paradigms of Gibson et al. and is absent in CM and DRG neurons.

Early spike-related effects in EMG

Several mechanisms can account for STA features with onset times that are too early to be mediated by monosynaptic connections from the trigger neuron to motoneurons (Fig. 18A), as shown schematically in Fig. 18, B–E.

SYNCHRONY EFFECTS. The majority of early effects began before and ended after the occurrence of the triggering action potential. Such effects are similar to the zero-delay peaks found in cross-correlograms of the activity of neighboring neurons in many areas of the CNS (Fetz et al. 1991; Singer 1993). These central peaks are evidence of common synaptic input that increases above chance the probability that the two neurons will discharge synchronously (Kirkwood and Sears 1978). Analogously, peaks (or troughs) that straddle the trigger time in STAs of EMG may reflect common input to the recorded cell and to another neuron with an excitatory (or inhibitory) synaptic connection to motoneurons (Fig. 18C) (Flament et al. 1992).

This conclusion is supported by the longer mean rise time of synchrony effects (6.5 ms) compared with postspike effects (2.2 ms). The STA of a neuron firing synchronously with a premotor cell can be predicted by the convolution of the postspike effect of the premotor cell with the cross-correlogram of activity between the two neurons. Central peaks in the cross-correlogram disperse the postspike effect in time, producing a rise time longer than that of the underlying postspike effect.

It might be expected that the conduction time of action potentials along motor axons would delay the onset time of synchrony effects in STAs until after the trigger. However, cross-correlogram peaks of the activity of pairs of neurons

typically last 10–20 ms (Fetz et al. 1991 for cortical neurons; Prut et al. 1996 for spinal interneurons). Such interactions among spinal cells would produce output effects dispersed in time by more than the conduction delay of motor axons.

Biphasic and oscillatory synchrony effects (Fig. 15, C and D) were not related to features of the autocorrelogram of the triggering interneuron. In many cases, the suppression of EMG was as large as the subsequent facilitation (Fig. 15C), yet the autocorrelograms of spinal interneurons did not show central peaks preceded by troughs of comparable dimensions. The firing rates of many neurons associated with complex synchrony effects also appeared too high to account for the long-duration suppressions that were observed (Lemon and Mantel 1989). In addition, two analytic tests performed on the data (selective triggering with spikes preceded by long intervals and deconvolution of STAs with the autocorrelogram of the triggering cell) failed to show any significant influence of autocorrelogram features on multiphasic synchrony effects. This suggests that these complex STA features reflect the activity in a population of premotor neurons that only weakly entrains the trigger cell.

Synchronous activity has been demonstrated in many different sensory and motor areas of the brain (e.g., Sanes and Donoghue 1993; Singer 1993; Welsh et al. 1995) and between motor units of the same and different muscles (Bremner et al. 1991a; Datta and Stephens 1990; DeLuca and Mambrito 1987; Sears and Stagg 1976). Motor-unit synchronization in human hand muscles is associated with coherent firing at a frequency of 16–32 Hz, suggesting that common inputs fire rhythmically (Farmer et al. 1993). This is consistent with reports of periodic features in the activity of corticospinal pathways (Baker et al. 1997; Conway et al. 1995; Murthy and Fetz 1996).

Our data suggest that some spinal interneurons, including PreM-INs, also exhibit synchronous and oscillatory activity during voluntary movements. The highly divergent nature of projections to the spinal cord (Baldissera et al. 1981; Jankowska 1992), the similarity between synchrony effects in STAs triggered from spinal interneurons and DRG neurons (Flament et al. 1992), and the similarity between the frequencies of oscillatory features in STAs triggered from interneurons and motor cortex (Baker et al. 1997; Murthy and Fetz 1996) suggest common afferent and descending inputs to spinal interneurons. In conclusion, synchrony features in STAs of EMG probably represent the collective activity of premotor circuits that affect the triggering cell. Our data suggest a model of spinal premotor circuitry in which a network of interconnected interneurons receives common supraspinal and feedback signals that tend to produce synchronized, occasionally rhythmic, firing of interneurons and motoneurons (Fig. 18E).

OTHER EARLY EFFECTS. Early STA features that do not straddle the trigger time probably are not due to the synchronous firing of the recorded cell and premotor neurons, as this would require highly unlikely relations between the firing of these neurons. For example, effects with onsets earlier than 10 ms before the trigger time would require common inputs that reliably drive neurons through three or more synapses.

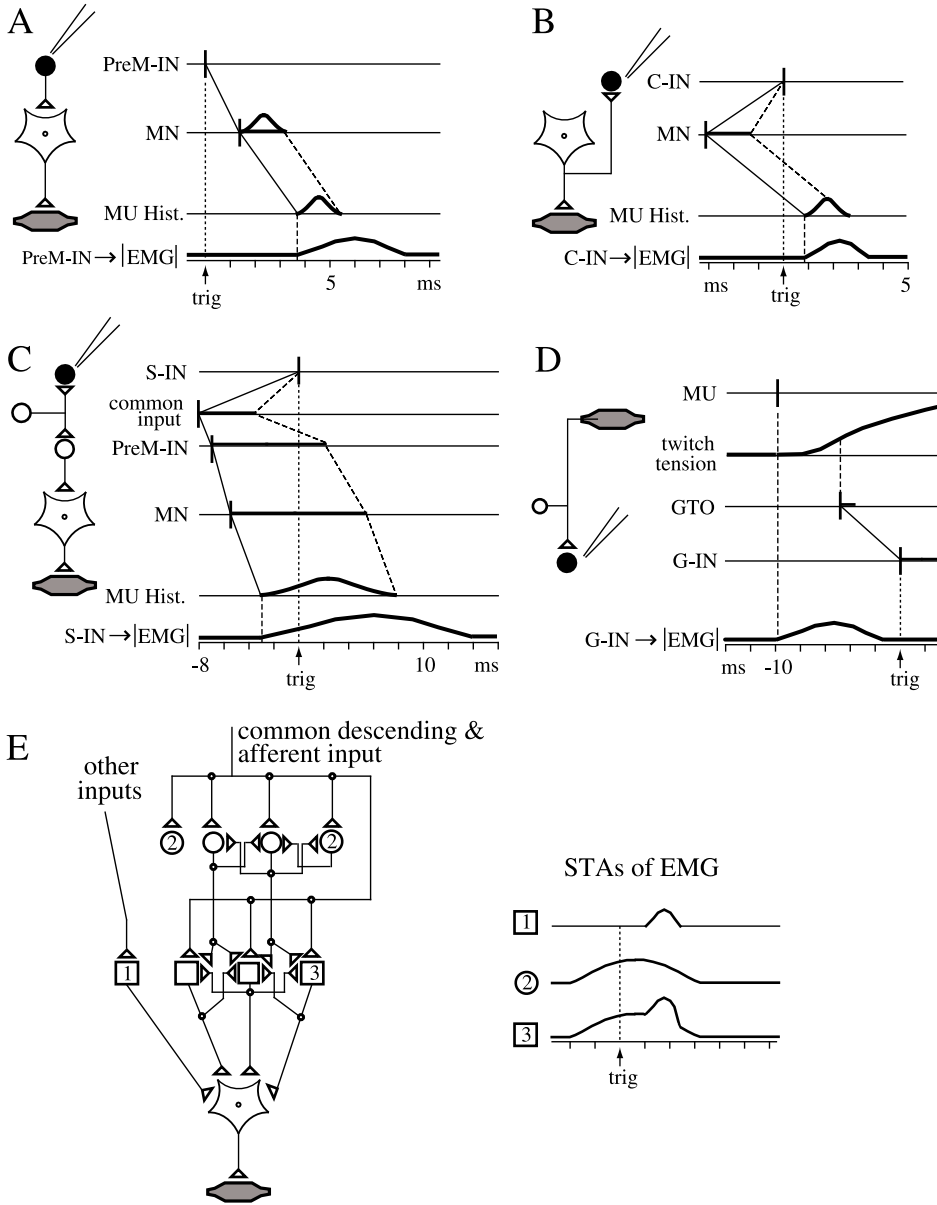

FIG. 18. Schematic diagrams of circuits that can account for spike-related effects reported in this paper. *A*: connectivity of a PreM-IN. *B*: motor axon collateral activates neuron C-IN, resulting in an early-posttrigger effect in STA triggered from C-IN. *C*: common input to a PreM-IN and neuron S-IN results in synchrony effect in STA triggered from S-IN. *D*: neuron G-IN is driven by input from a Golgi tendon organ (GTO) that is activated synchronously with contraction of a motor unit, resulting in pretrigger effect in STA triggered from G-IN. In *A–D*, the neuron triggering the STA is shown as a filled circle in the circuit diagram; the timing of activity is shown (*right* of each circuit diagram). Events for each neuron show the earliest possible occurrence of action potentials, and thick horizontal lines indicate other possible occurrence times, representing the width of the central peak in the cross-correlogram between the triggering neuron [or the motoneuron (MN), in *D*] and the other cells in the circuit. Cross-correlogram is shown *above* the horizontal line for MN in *A*. Diagonal lines indicate synaptic delays that result in probabilistic increases in firing of postsynaptic cell. STAs of rectified EMG are shown in *bottom row*. In *A–C*, MU Hist depicts the histogram of motoneuron firing in relation to the trigger time. Longer duration of the spike-related feature in the STA as compared with MU Hist reflects the width of the muscle unit action potential and the recruitment of other motoneurons by the trigger cell (Palmer and Fetz 1985). In *D*, twitch tension shows the time course of the increase in force produced by activation of the motoneuron. Duration of the spike-related feature in the STA reflects the width of the muscle-unit action potential and the histogram of firing of G-IN relative to the motoneuron. *E*: highly interconnected spinal premotor network, as suggested by present data. This diagram is schematic: all pathways to motoneurons and connections between interneurons are not necessarily present in the spinal cord. STAs of numbered neurons shown to right: 1, postspike effect; 2, synchrony effect; 3, postspike effect superimposed on synchrony effect.

Instead, pretrigger effects may represent sensory responses of interneurons receiving input from afferents that discharge in close association with individual motor units or groups of motor units (Fig. 18*D*). For example, interneurons that receive strong input from Golgi tendon organs tend to fire at a relatively fixed latency after discharge of the motor units in series with those receptors. These motor units will appear in a STA as an increased level of EMG before action potentials of this interneuron. Inputs from muscle spindle afferents activated by beta motoneuron discharge could generate similar STAs.

Early-posttrigger effects (Fig. 18*B*) could be produced by inputs from collaterals of motor axons or PreM-INS. The onset latency of the STA feature represents the difference between the conduction delay from the motoneuron or PreM-IN to the recorded cell and the delay to the muscle fibers. These circuits would produce spike-related effects with post-trigger latencies shorter than those of the PreM-IN or moto-

neuron. The only interneuron known to be excited by motoneuron collaterals is the Renshaw cell, which exerts recurrent inhibition on the same motoneurons (see Baldissera et al. 1981). Early-posttrigger effects were not accompanied by later postspike suppressions of the target muscles, but STAs from Renshaw cells would not necessarily reveal the recurrent inhibition. The greater efficacy of the cell's excitatory input from motoneurons relative to the efficacy of its inhibitory output to motoneurons (see Baldissera et al. 1981), could produce a STA with an early effect that masks the recurrent inhibition.

Control of motoneuron activity

The firing pattern and output effects of 24 PreM-INS were well matched to the alternating activation of forearm motoneurons during the task: they facilitated primary flexor or extensor muscles, were active when their target muscles

were active, and were silent for torques in the opposite direction. However, 71 PreM-INs with postspike effects in primary wrist movers were active for both directions of torque and/or had postspike effects that were not simply correlated with the cell's firing pattern during the task (Fig. 12). Responses often matched target muscle activity for torques in one direction, but for opposite torques these neurons either facilitated muscles that were silent or inhibited muscles that were actively recruited.

The widespread subthreshold facilitatory input from PreM-INs to motoneurons may serve as an excitatory bias that keeps motoneuron membrane potentials close to threshold under movement conditions. Biasing inputs would make activation of motoneurons easier and would decrease reaction times. The subthreshold excitation of motoneurons of muscles that are not recruited for a particular movement would increase their sensitivity to sensory inputs when they might otherwise be deeply inhibited. This hypothesis is consistent with our observation that the background activity of some PreM-INs decreased at times when the animal was not waiting for a movement cue (i.e., visual targets not presented). PreM-INs with tonic, unmodulated activity during the task are particularly suited to this biasing function.

Incongruent relations between a neuron's firing pattern and output effects also could result from synaptic inputs that are organized to control movements other than wrist flexion or extension. For example, PreM-INs that cofacilitate flexor and extensor muscles may be activated maximally during cocontraction tasks. The recruitment of these neurons during alternating flexion/extension would suggest that cocontraction and reciprocal motor patterns are generated by common supraspinal or interneuronal pathways (Feldman 1981; Humphrey and Reed 1983). Because most PreM-INs facilitated muscle activity, it appears that these shared pathways are primarily excitatory.

Clearly the incongruent facilitatory input is insufficient to activate motoneurons that are not being recruited, probably for two reasons. First, the firing rate of most PreM-INs was significantly higher for their preferred directions of torque than for nonpreferred directions. Thus the level of excitation of motoneurons for opposite torques is reduced significantly. Second, extensive inhibitory inputs to motoneurons (Baldissera et al. 1981) counter the inappropriate excitation produced by facilitatory PreM-INs during movements in which the target muscles are not recruited. Alternatively, for incongruent postspike effects that are mediated by disynaptic connections, inappropriate effects would be avoided if the intervening interneuron is inactive.

However, we found very few interneurons producing postspike suppression of muscle activity. This is partially due to a limitation of the spike-triggered averaging technique. STAs of EMG can identify output effects only for neurons that are coactive with their target muscles. Connections between neurons and target muscles that have strictly reciprocal activity patterns—for example, inhibitory PreM-INs that are silent when the muscles they suppress are active—will not be detected with this technique. This reasoning would suggest that many inhibitory PreM-INs in the spinal cord are active in a strict alternating pattern during voluntary flexion and extension of the wrist. These were not detected by STAs because they fired only when their target

muscles were suppressed. Ia inhibitory interneurons probably were included in this group—only one PreM-IN (shaded circle in Fig. 12, “Sup antag” column and “high-low” row) had properties expected of this neuron type (Jankowska 1992). “Unidentified interneurons” with strictly alternating activity patterns, described in the companion paper [Maier et al. (1998), in Table 2, the 84 U-INs (20% of U-INs) with “no activity” in the nonpreferred direction], probably include inhibitory PreM-INs. This conclusion suggests a difference in the organization of excitatory and inhibitory inputs to cervical motoneurons. Excitatory effects seem to be distributed to all wrist muscles during wrist movements, whereas specific inhibitory effects sharpen the reciprocal activation of flexors and extensors.

We found very few PreM-INs with reciprocal output effects on flexor and extensor muscles. This represents an interesting difference between spinal PreM-INs and the other three populations of premotor neurons studied under similar conditions (Fig. 17). Kasser and Cheney (1985) demonstrated that 28% of CM cells produce reciprocal postspike suppressions in antagonists of their facilitated target muscles. They activated CM cells with glutamate iontophoresis during movements in their nonpreferred direction, when they were normally silent. Among RM cells, 29% also had reciprocal effects (Mewes and Cheney 1991). Although not tested with glutamate activation, most DRG cells, which were likely Ia afferents (Flament et al. 1992), also would be expected to exert reciprocal inhibition through the Ia inhibitory interneuron (Baldissera et al. 1981). In contrast, only 4% of the spinal PreM-INs had reciprocal effects on flexor and extensor muscles. This is probably an underestimate: some of the 24 unidirectionally active PreM-INs (Fig. 12) might have exhibited reciprocal effects if tested with glutamate activation. Nonetheless, the reciprocal control of flexor and extensor muscles seems to be determined largely by supraspinal inputs during wrist movements.

Our description of interneuronal responses in this paper has focused on the relation between the activity of PreM-INs and the direction of torque produced at the wrist. Spinal interneurons not only exert control over the timing of motoneuron activity but also help determine the firing pattern and rate at which motoneurons discharge. These aspects of the parametric control of motoneuron activity, which determine the time course and level of torque exerted at the joint, are described in the following paper (Maier et al. 1998).

We thank E. Jankowska for valuable comments on the manuscript, J. Garlid and L. Shupe for expert technical assistance, K. Elias for editorial assistance, and M. Domenowske for the illustration in Fig. 2.

This study was supported by National Institutes of Health Grants RO1-NS-12542, F32-NS-9189, and RR-00166; American Paralysis Association Grants PB1-9402-1 and PBR2-9502; and a Swiss National Science Foundation fellowship (M. A. Maier).

Present address of M. A. Maier: Sobell Dept. of Neurophysiology, Institute of Neurology, Queen Square, London WC1N 3BG, UK.

Address for reprint requests: S. I. Perlmutter, Dept. of Physiology and Biophysics, Box 357330, University of Washington, Seattle, WA 98195-7330.

Received 2 December 1997; accepted in final form 28 July 1998.

REFERENCES

- AGGELLOPOULOS, N. C., CHAKRABARTY, S., AND EDGLEY, S. A. Evoked excitability changes at the terminals of midlumbar premotor interneurons in the cat spinal cord. *J. Neurosci.* 17: 1512–1518, 1997.

- ANDERSON, P. A., HENLEY, M. B., GRADY, M. S., MONTESANO, P. X., AND WINN, H. R. Posterior cervical arthrodesis with AO reconstruction plates and bone graft. *Spine* 16: S72–S79, 1991.
- ARMAND, J., OLIVIER, E., EDGLEY, S. A., AND LEMON, R. N. Postnatal development of corticospinal projections from motor cortex to the cervical enlargement in the macaque monkey. *J. Neurosci.* 17: 251–266, 1997.
- BAKER, S. N., OLIVIER, E., AND LEMON, R. N. Coherent oscillations in monkey motor cortex and hand muscle EMG show task-dependent modulation. *J. Physiol. (Lond.)* 501: 225–241, 1997.
- BALDISSERA, F., HULTBORN, H., AND ILLERT, M. Integration in spinal neuronal systems. In: *Handbook of Physiology. The Nervous System. Motor Control*. Bethesda, MD: Am. Physiol. Soc., 1981, sect. 1, vol. II, part 2, p. 509–595.
- BELHAJ-SAIF, A., KARRER, J. H., AND CHENEY, P. D. Distribution and characteristics of poststimulus effects in proximal and distal forelimb muscles from red nucleus in the monkey. *J. Neurophysiol.* 79: 1777–1789, 1998.
- BERKOWITZ, A. AND STEIN, P.S.G. Activity of descending propriospinal axons in the turtle hindlimb enlargement during two forms of fictive scratching: broad tuning to regions of the body surface. *J. Neurosci.* 14: 5089–5104, 1994.
- BORTOFF, G. A. AND STRICK, P. L. Corticospinal terminations in two new-world primates: further evidence that corticomotoneuronal connections provide part of the neural substrate for manual dexterity. *J. Neurosci.* 13: 5105–5118, 1993.
- BREMNER, F. D., BAKER, J. R., AND STEPHENS, J. A. Correlation between the discharges of motor units recorded from the same and from different finger muscles in man. *J. Physiol. (Lond.)* 432: 355–380, 1991a.
- BREMNER, F. D., BAKER, J. R., AND STEPHENS, J. A. Variation in the degree of synchronization exhibited by motor units lying in different finger muscles in man. *J. Physiol. (Lond.)* 432: 381–399, 1991b.
- BRINK, E., HARRISON, P. J., JANKOWSKA, E., MCCREA, D., AND SKOOG, B. Post-synaptic potentials in a population of motoneurons following activity of single interneurons in the cat. *J. Physiol. (Lond.)* 343: 341–359, 1983.
- BROMBERG, M. B. AND FETZ, E. E. Responses of single units in cervical spinal cord of alert monkeys. *Exp. Neurol.* 55: 469–482, 1977.
- BUYS, E. J., LEMON, R. N., MANTEL, G. W., AND MUIR, R. B. Selective facilitation of different hand muscles by single corticospinal neurons in the conscious monkey. *J. Physiol. (Lond.)* 381: 529–549, 1986.
- CANGIANO, A. AND LUTZEMBERGER, L. The action of selectively activated group II muscle afferent fibers on extensor motoneurons. *Brain Res.* 41: 475–478, 1972.
- CARP, J. S. Physiological properties of primate lumbar motoneurons. *J. Neurophysiol.* 68: 1121–1132, 1992.
- CAVALLARI, P., EDGLEY, S. A., AND JANKOWSKA, E. Post-synaptic actions of midlumbar interneurons on motoneurons of hind-limb muscles in the cat. *J. Physiol. (Lond.)* 389: 675–690, 1987.
- CHEEMA, S. S., RUSTIONI, A., AND WHITSEL, B. L. Light and electron microscopic evidence for a direct corticospinal projection to superficial laminae of the dorsal horn in cats and monkeys. *J. Comp. Neurol.* 225: 276–290, 1984.
- CHENEY, P. D. AND FETZ, E. E. Functional classes of primate corticomotoneuronal cells and their relation to active force. *J. Neurophysiol.* 44: 773–791, 1980.
- CHENEY, P. D. AND FETZ, E. E. Comparable patterns of muscle facilitation evoked by individual corticomotoneuronal (CM) cells and by single intracortical microstimuli in primates: evidence for functional groups of CM cells. *J. Neurophysiol.* 53: 786–804, 1985.
- CHENEY, P. D., FETZ, E. E., AND MEWES, K. Neural mechanisms underlying corticospinal and rubrospinal control of limb movements. *Prog. Brain Res.* 87: 213–252, 1991.
- CLELAND, C. L. AND HOFFER, J. A. Chronic recordings from neurons in the spinal cord of freely moving cats: cutaneous spinocerebellar neurons. *Neurosci. Lett. (Suppl.)* 26: S364, 1986.
- CLOUGH, J.F.M., KERNELL, D., AND PHILLIPS, C. G. The distribution of monosynaptic excitation from the pyramidal tract and from primary spindle afferents to motoneurons of the baboon's hand and forearm. *J. Physiol. (Lond.)* 198: 145–166, 1968.
- COLLINS, J. G., REN, K., SAITO, Y., IWASAKI, H., AND TANG, J. Plasticity of some spinal dorsal horn neurons as revealed by pentobarbital-induced disinhibition. *Brain Res.* 525: 189–197, 1990.
- CONWAY, B. A., HALLIDAY, D. M., FARMER, S. F., SHAHANI, U., MAAS, P., WEIR, A. I., AND ROSENBERG, J. R. Synchronization between motor cortex and spinal motoneuronal pool during the performance of a maintained motor task in man. *J. Physiol. (Lond.)* 489: 917–924, 1995.
- COPE, T. C., FETZ, E. E., AND MATSUMURA, M. Cross-correlation assessment of synaptic strength of single Ia fibre connections with triceps surae motoneurons in cats. *J. Physiol. (Lond.)* 390: 161–188, 1987.
- COURTNEY, K. R. AND FETZ, E. E. Unit responses recorded from cervical spinal cord of awake monkey. *Brain Res.* 53: 445–450, 1973.
- CRUTCHER, M. D. AND ALEXANDER, B. E. Movement-related neuronal activity selectively coding either direction or muscle pattern in three motor areas of the monkey. *J. Neurophysiol.* 64: 151–163, 1990.
- CZARKOWSKA, J., JANKOWSKA, E., AND SYBIRSKA, E. Common interneurons in reflex pathways from group Ia and Ib afferents of knee flexors and extensors in the cat. *J. Physiol. (Lond.)* 310: 367–380, 1981.
- DATTA, A. K. AND STEPHENS, J. A. Synchronization of motor unit activity during voluntary contractions in man. *J. Physiol. (Lond.)* 422: 397–419, 1990.
- DELUCA, C. J. AND MAMBRITO, B. Voluntary control of motor units in human antagonist muscles: co-activation and reciprocal activation. *J. Neurophysiol.* 58: 525–542, 1987.
- DUM, R. P. AND STRICK, P. L. Spinal cord terminations of the medial wall motor areas in macaque monkeys. *J. Neurosci.* 16: 6513–6525, 1996.
- ECCLES, R. M. AND LUNDBERG, A. Synaptic actions in motoneurons by afferents which may evoke the flexion reflex. *Arch. Ital. Biol.* 97: 199–221, 1959.
- ECCLES, R. M., PHILLIPS, C. G., AND CHIEN-PING, W. Motor innervation, motor unit organization and afferent innervation of M. extensor digitorum communis of the baboon's forearm. *J. Physiol. (Lond.)* 198: 179–192, 1968.
- EVARTS, E. V. Relation of pyramidal tract activity to force exerted during voluntary movement. *J. Neurophysiol.* 31: 14–27, 1968.
- FARMER, S. F., BREMNER, F. D., HALLIDAY, D. M., ROSENBERG, J. R., AND STEPHENS, J. A. The frequency content of common presynaptic inputs to motoneurons studied during voluntary isometric contractions in man. *J. Physiol. (Lond.)* 470: 127–155, 1993.
- FELDMAN, A. G. The composition of central programs subserving horizontal eye movements in man. *Biol. Cybern.* 42: 107–116, 1981.
- FETZ, E. E. AND CHENEY, P. D. Postspike facilitation of forelimb muscle activity by primate corticomotoneuronal cells. *J. Neurophysiol.* 44: 751–772, 1980.
- FETZ, E. E., CHENEY, P. D., MEWES, K., AND PALMER, S. Control of forelimb muscle activity by populations of corticomotoneuronal and rubromotoneuronal cells. *Prog. Brain Res.* 80: 437–449, 1989.
- FETZ, E. E., TOYAMA, K., AND SMITH, W. Synaptic interactions between cortical neurons. In: *Cerebral Cortex. Altered Cortical States*, edited by A. Peters and E. G. Jones. New York: Plenum, 1991, vol. IX, p. 1–47.
- FLAMENT, D., FORTIER, P. A., AND FETZ, E. E. Response patterns and post-spike effects of peripheral afferents in dorsal root ganglia of behaving monkeys. *J. Neurophysiol.* 67: 875–889, 1992.
- GARNETT, R. AND STEPHENS, J. A. The reflex responses of single motor units in human first dorsal interosseous muscle following cutaneous afferent stimulation. *J. Physiol. (Lond.)* 303: 351–364, 1980.
- GIBSON, A. R., HOUK, J. C., AND KOHLERMAN, N. J. Magnocellular red nucleus activity during different types of limb movement in the macaque monkey. *J. Physiol. (Lond.)* 358: 527–549, 1985.
- GILLIAT, R. W., HOPF, H. C., RUDGE, P., AND BARAISTER, M. Axonal velocities of motor units in the hand and foot muscles of the baboon. *J. Neurol. Sci.* 29: 249–258, 1976.
- GUSTAFFSON, B. AND JANKOWSKA, E. Direct and indirect activation of nerve cells by electrical pulses applied extracellularly. *J. Physiol. (Lond.)* 258: 33–61, 1976.
- HECKMAN, C. J. AND BINDER, M. D. Analysis of effective synaptic currents generated by homonymous Ia afferent fibers in motoneurons of the cat. *J. Neurophysiol.* 60: 1946–1966, 1988.
- HONGO, T., KITAZAWA, S., OHKI, Y., AND XI, M.-C. Functional identification of last-order interneurons of skin reflex pathways in the cat forelimb segments. *Brain Res.* 505: 167–170, 1989.
- HULTBORN, H., MEUNIER, S., PIERROT-DESEILLIGNY, E., AND SHINDO, M. Changes in presynaptic inhibition of Ia fibres at the onset of voluntary contraction in man. *J. Physiol. (Lond.)* 389: 757–772, 1987.
- HUMPHREY, D. R. AND REED, D. J. Separate cortical systems for control of joint movement and joint stiffness: reciprocal activation and coactivation of antagonist muscles. In: *Motor Control Mechanisms in Health and Disease*, edited by J. E. Desmedt. New York: Raven, 1983, p. 347–372.

- JANKOWSKA, E. Interneuronal relay in spinal pathways from proprioceptors. *Prog. Neurobiol.* 38: 335–378, 1992.
- JANKOWSKA, E. AND ROBERTS, W. J. Synaptic actions of single interneurons mediating reciprocal Ia inhibition of motoneurons. *J. Physiol. (Lond.)* 222: 623–642, 1972.
- JENNY, A. B. AND INUKAI, J. Principles of motor organization of the monkey cervical spinal cord. *J. Neurosci.* 3: 567–575, 1983.
- JORDAN, L. Brainstem and spinal cord mechanisms for the initiation of locomotion. In: *Neurobiological Basis of Human Locomotion*, edited by M. Shimamura, S. Grillner, and V. R. Edgerton. Tokyo: Japan Scientific Societies, 1991, p. 3–20.
- KASSER, R. J. AND CHENEY, P. D. Characteristics of corticomotoneuronal postspike facilitation and reciprocal suppression of EMG activity in the monkey. *J. Neurophysiol.* 53: 959–978, 1985.
- KIRKWOOD, P. A. AND SEARS, T. A. The synaptic connexions to intercostal motoneurons as revealed by the average common excitation potential. *J. Physiol. (Lond.)* 275: 103–134, 1978.
- KUYPERS, H.G.J.M. Anatomy of the descending pathways. In: *Handbook of Physiology. The Nervous System. Motor Control*. Bethesda, MD: Am. Physiol. Soc., 1981, sect. 1, vol. II, part 2, p. 597–666.
- LEMON, R. N. AND MANTEL, G. W. The influence of changes in discharge frequency of corticospinal neurons on hand muscles in the monkey. *J. Physiol. (Lond.)* 413: 351–378, 1989.
- LEMON, R. N., MANTEL, G. W., AND MUIR, R. B. Corticospinal facilitation of hand muscles during voluntary movement in the conscious monkey. *J. Physiol. (Lond.)* 381: 497–527, 1986.
- LUNDBERG, A., MALMGREN, K., AND SCHOMBURG, E. D. Reflex pathways from group II muscle afferents. III. Secondary spindle afferents and the FRA: a new hypothesis. *Exp. Brain Res.* 65: 294–306, 1987.
- MAIER, M. A., PERLMUTTER, S. I., AND FETZ, E. E. Response patterns and force relations of monkey spinal interneurons during active wrist movement. *J. Neurophysiol.* 80: 2495–2513, 1998.
- MCCREA, D. A. Can sense be made of spinal interneuron circuits? *Behav. Brain Sci.* 15: 633–643, 1992.
- MCKIERNAN, B. J. AND CHENEY, P. D. Modeling perispikes features in spike triggered averages of rectified EMG activity. *Soc. Neurosci. Abstr.* 19: 1207, 1993.
- MEWES, K. AND CHENEY, P. D. Postspike facilitation (PSpF) of EMG activity from neurons in primate motor thalamus. *Soc. Neurosci. Abstr.* 16: 425, 1990.
- MEWES, K. AND CHENEY, P. D. Facilitation and suppression of wrist and digit muscles from single rubromotoneuronal cells in the awake monkey. *J. Neurophysiol.* 66: 1965–1977, 1991.
- MEWES, K. AND CHENEY, P. D. Primate rubromotoneuronal cells: parametric relations and contribution to wrist movement. *J. Neurophysiol.* 72: 14–30, 1994.
- MURPHY, J. T., KWAN, H. C., MACKEY, W. A., AND WONG, Y. C. Activity of primate precentral neurons during voluntary movements triggered by visual signals. *Brain Res.* 236: 429–449, 1982.
- MURTHY, V. N. AND FETZ, E. E. Oscillatory activity in sensorimotor cortex of awake monkeys: synchronization of local field potentials and relation to behavior. *J. Neurophysiol.* 76: 3949–3967, 1996.
- NIELSEN, J. AND KAGAMIHARA, Y. The regulation of disynaptic reciprocal Ia inhibition during co-contraction of antagonistic muscles in man. *J. Physiol. (Lond.)* 456: 373–391, 1992.
- PALMER, S. S. AND FETZ, E. E. Effects of single intracortical microstimuli in motor cortex on activity of identified forearm motor units in behaving monkeys. *J. Neurophysiol.* 54: 1194–1212, 1985.
- PIERROT-DESEILLIGNY, E. Peripheral and descending control of neurons mediating non-monosynaptic Ia excitation to motoneurons: a presumed propriospinal system in man. *Prog. Brain Res.* 80: 305–314, 1989.
- PRUT, Y., PERLMUTTER, S. I., AND FETZ, E. E. Periodic firing and interactions of spinal interneurons of awake behaving monkeys. *Soc. Neurosci. Abstr.* 22: 1846, 1996.
- RALSTON, D. D. AND RALSTON, H. J. The terminations of corticospinal tract axons in the macaque monkey. *J. Comp. Neurol.* 242: 325–337, 1985.
- ROBINSON, F. R., HOUK, J. C., AND GIBSON, A. R. Limb specific connections of the cat magnocellular red nucleus. *J. Comp. Neurol.* 257: 553–577, 1987.
- RUDOMIN, P., SOLODKIN, M., AND JIMENEZ, I. Synaptic potentials of primary afferent fibers and motoneurons evoked by single intermediate nucleus interneurons in the cat spinal cord. *J. Neurophysiol.* 57: 1288–1313, 1987.
- SANES, J. N. AND DONOGHUE, J. P. Oscillations in local field potentials of the primate motor cortex during voluntary movement. *Proc. Natl. Acad. Sci. USA* 90: 4470–4474, 1993.
- SEARS, T. A. AND STAGG, D. Short-term synchronization of intercostal motoneurone activity. *J. Physiol. (Lond.)* 263: 357–381, 1976.
- SHEFNER, J. M., BERMAN, S. A., SARKARATI, M., AND YOUNG, R. R. Recurrent inhibition is increased in patients with spinal cord injury. *Neurology* 42: 2162–2168, 1992.
- SHERRINGTON, C. S. Flexion-reflex of the limb, crossed extension-reflex, and reflex stepping and standing. *J. Physiol. (Lond.)* 40: 28–121, 1910.
- SINGER, W. Synchronization of cortical activity and its putative role in information processing and learning. *Annu. Rev. Physiol.* 55: 349–374, 1993.
- SOJA, P. J., FRAGOSO, M. C., CAIRNS, B. E., AND JIA, W. G. Dorsal spinocerebellar tract neurons in the chronic intact cat during wakefulness and sleep: analysis of spontaneous spike activity. *J. Neurosci.* 16: 1260–1272, 1996.
- SORKIN, L. S., MORROW, T. J., AND CASEY, K. L. Physiological identification of afferent fibers and postsynaptic sensory neurons in the spinal cord of the intact, awake cat. *Exp. Neurol.* 99: 412–427, 1988.
- STEIN, R. B. AND KEARNEY, R. E. Nonlinear behavior of muscle reflexes at the human ankle joint. *J. Neurophysiol.* 73: 65–72, 1995.
- TERAKADO, Y. AND YAMAGUCHI, T. Last-order interneurons controlling activity of elbow flexor motoneurons during forelimb fictive locomotion in the cat. *Neurosci. Lett.* 111: 292–296, 1990.
- THACH, W. T. Correlation of neuronal discharge with pattern and force of muscular activity, joint position, and direction of intended next movement in motor cortex and cerebellum. *J. Neurophysiol.* 41: 654–676, 1978.
- WALL, P. D., FREEMAN, J., AND MAJOR, D. Dorsal horn cells in spinal and in freely moving rats. *Exp. Neurol.* 19: 519–529, 1967.
- WELSH, J. P., LANG, E. J., SUGIHARA, I., AND LLINAS, R. Dynamic organization of motor control within the olivocerebellar system. *Nature* 374: 453–457, 1995.
- WILSON, V. J. AND PETERSON, B. W. Vestibulospinal and reticulospinal systems. In: *Handbook of Physiology. The Nervous System. Motor Control*. Bethesda, MD: Am. Physiol. Soc., 1981, sect. 1, vol. II, part 2, p. 667–702.