

Treatment Naïve

# Sofosbuvir + RBV in Treatment-Naïve Genotypes 2,3 FISSION Trial\*

\*Note: Published in NEJM in tandem with **NEUTRINO** Trial (Genotypes 1,4,5,6)

Lawitz E, et al. N Engl J Med. 2013;368:1878-87.

# Sofosbuvir + Ribavirin for Treatment-Naïve HCV GT 2 or 3

## FISSION Trial: Features

### FISSION Trial: Features

- **Design:** Randomized, controlled, open-label phase 3 non-inferiority trial comparing sofosbuvir + ribavirin versus PEG + ribavirin in HCV GT 2,3
- **Setting:** 97 sites in US, Australia, New Zealand, Italy, Sweden, and the Netherlands, enrolled Dec 2011-May 2012
- **Entry Criteria**
  - Treatment-naïve, chronic HCV Genotype 2 or 3
  - HCV RNA  $\geq$  10,000 IU/ml
- **Patient Characteristics**
  - N = 499 HCV-monoinfected patients
  - HCV Genotype: 2 (28%); 3 (72%)
  - IL28B Genotype: 57% non-CC
  - Age and Sex: mean age 48 (range 19-77); 66% male
  - Race: 87% white; 3.4% black
  - Liver disease: 20% had cirrhosis
- **Primary End-Point:** SVR12

# Sofosbuvir + Ribavirin for Treatment-Naïve HCV GT 2 or 3

## FISSION Trial: Design

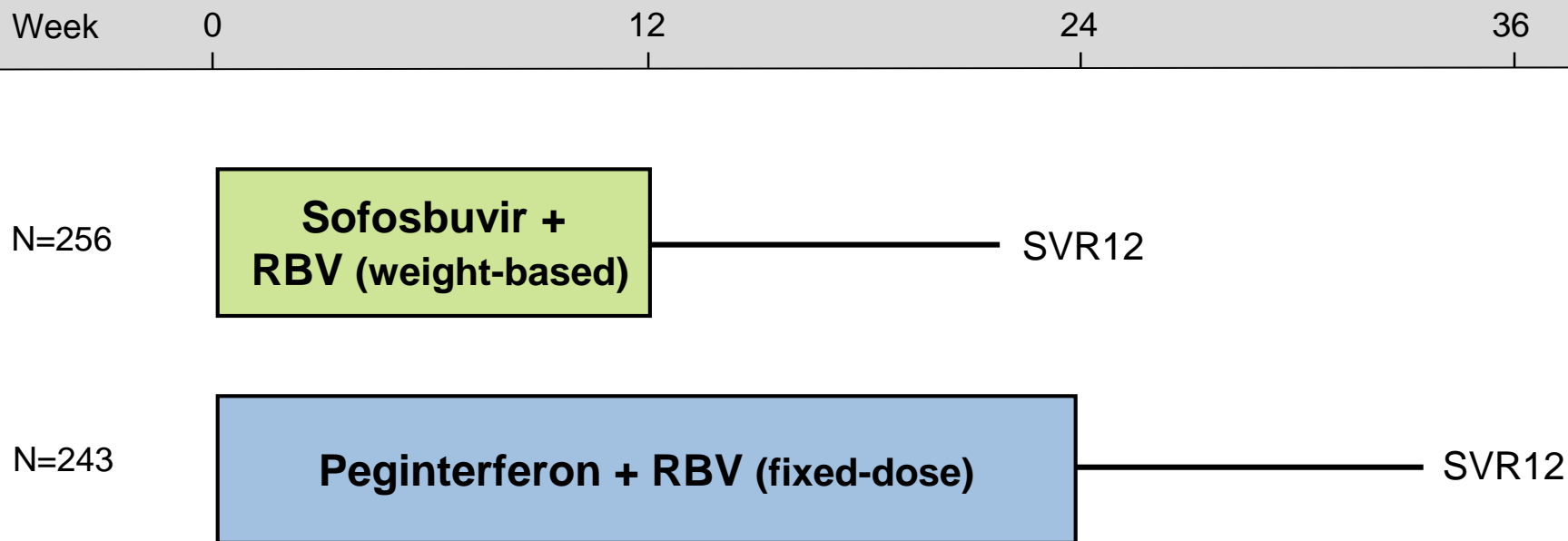

### Drug Dosing

Sofosbuvir: 400 mg once daily

Peginterferon alfa-2a: 180 µg once weekly

Weight-based Ribavirin (in 2 divided doses): 1000 mg/day if < 75 kg or 1200 mg/day if ≥ 75 kg

Fixed-dose Ribavirin (in 2 divided doses): 800 mg/day

# Sofosbuvir + Ribavirin for Treatment-Naïve HCV GT 2 or 3 FISSION Trial: Results

FISSION: HCV RNA <25 IU/ml by Study Timepoint (GT 2, 3 Combined)

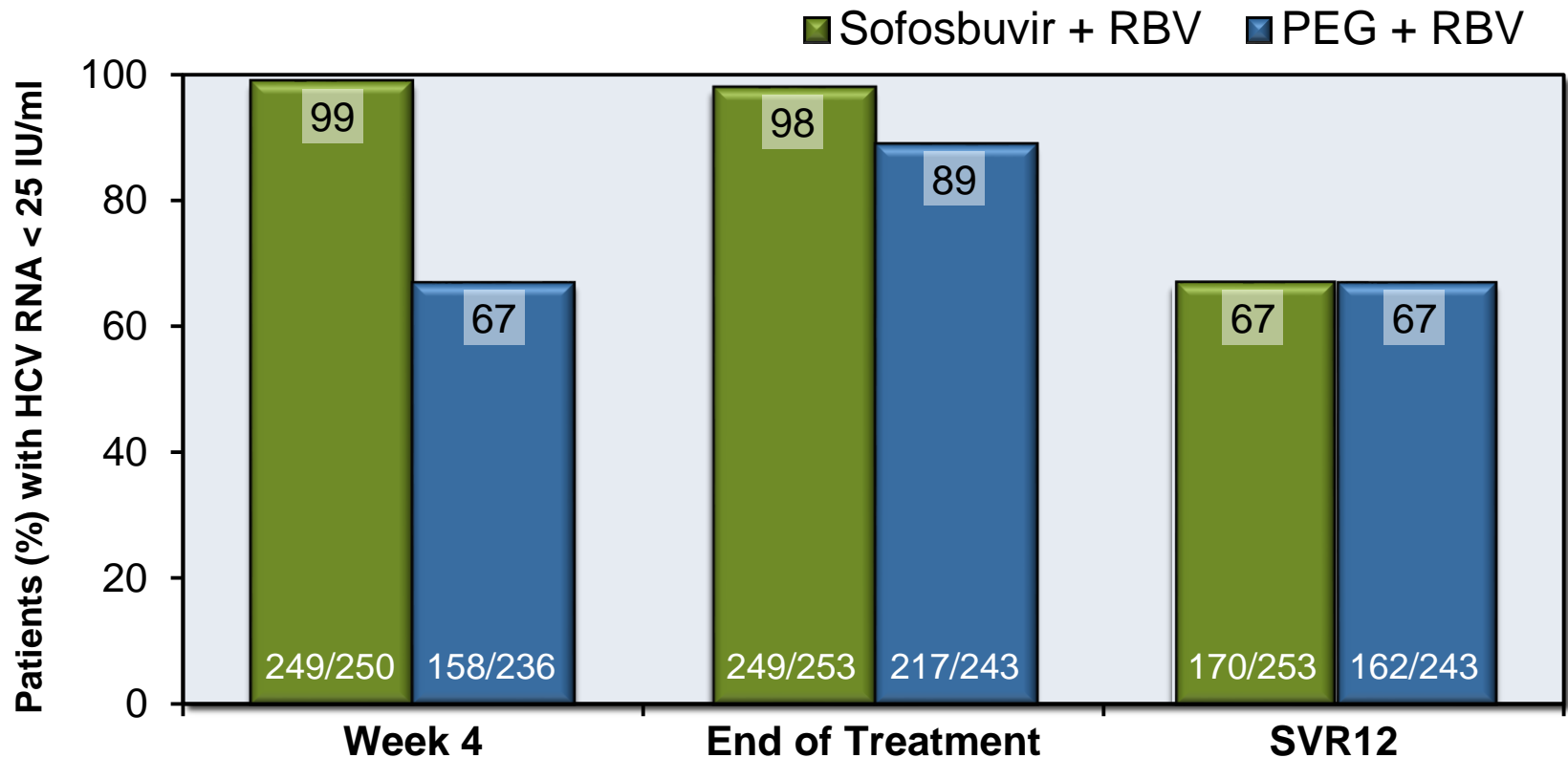

RBV = Ribavirin; PEG = Peginterferon

Source: Lawitz E, et al. N Engl J Med. 2013;368:1878-87.

# Sofosbuvir + Ribavirin for Treatment-Naïve HCV GT 2 or 3

## FISSION Trial: Results

### FISSION: SVR12 by Genotype

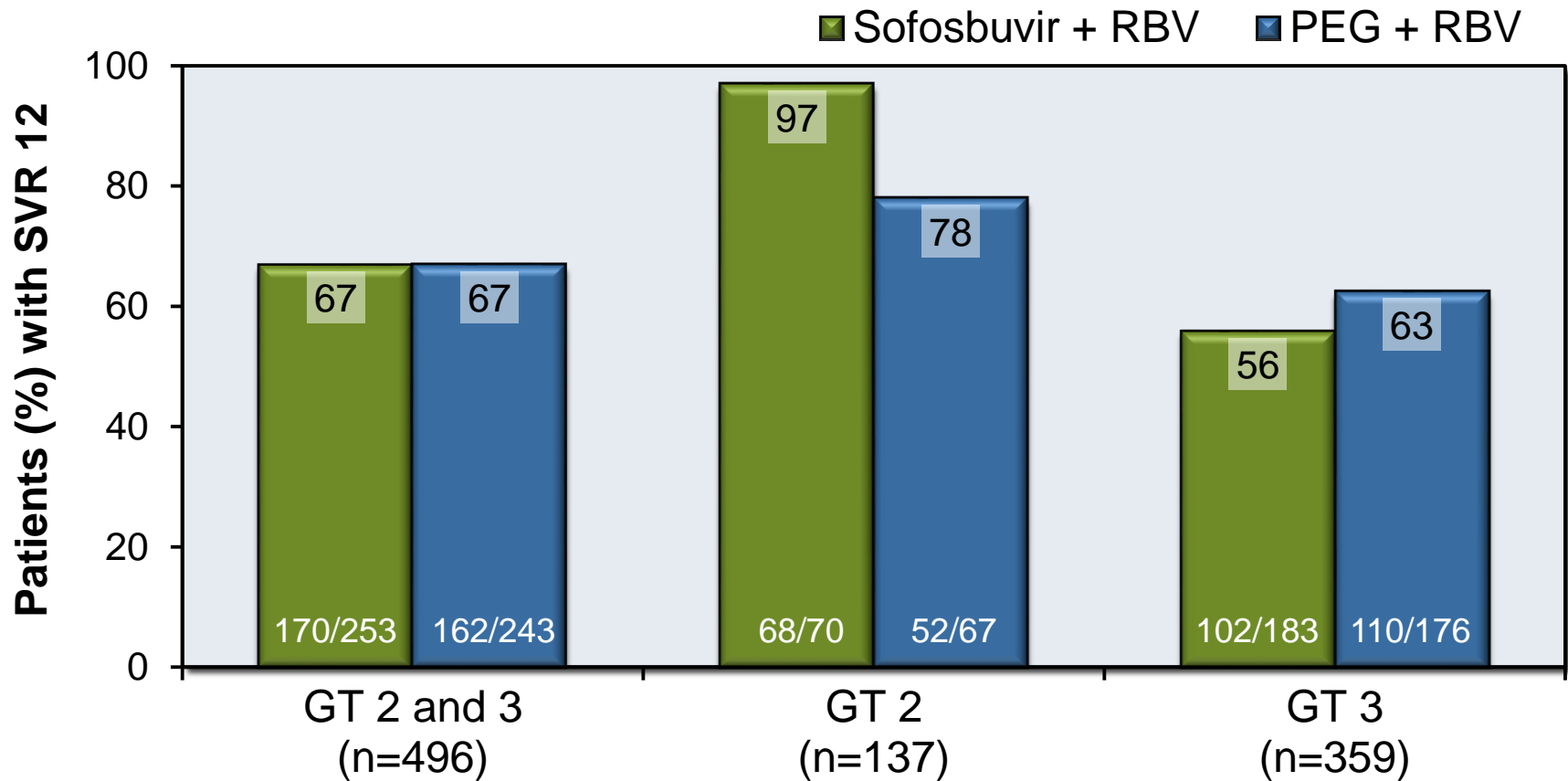

RBV = Ribavirin; PEG = Peginterferon

# Sofosbuvir + Ribavirin for Treatment-Naïve HCV GT 2 or 3 FISSION Trial: Results

## FISSION: SVR12 by Presence of Cirrhosis

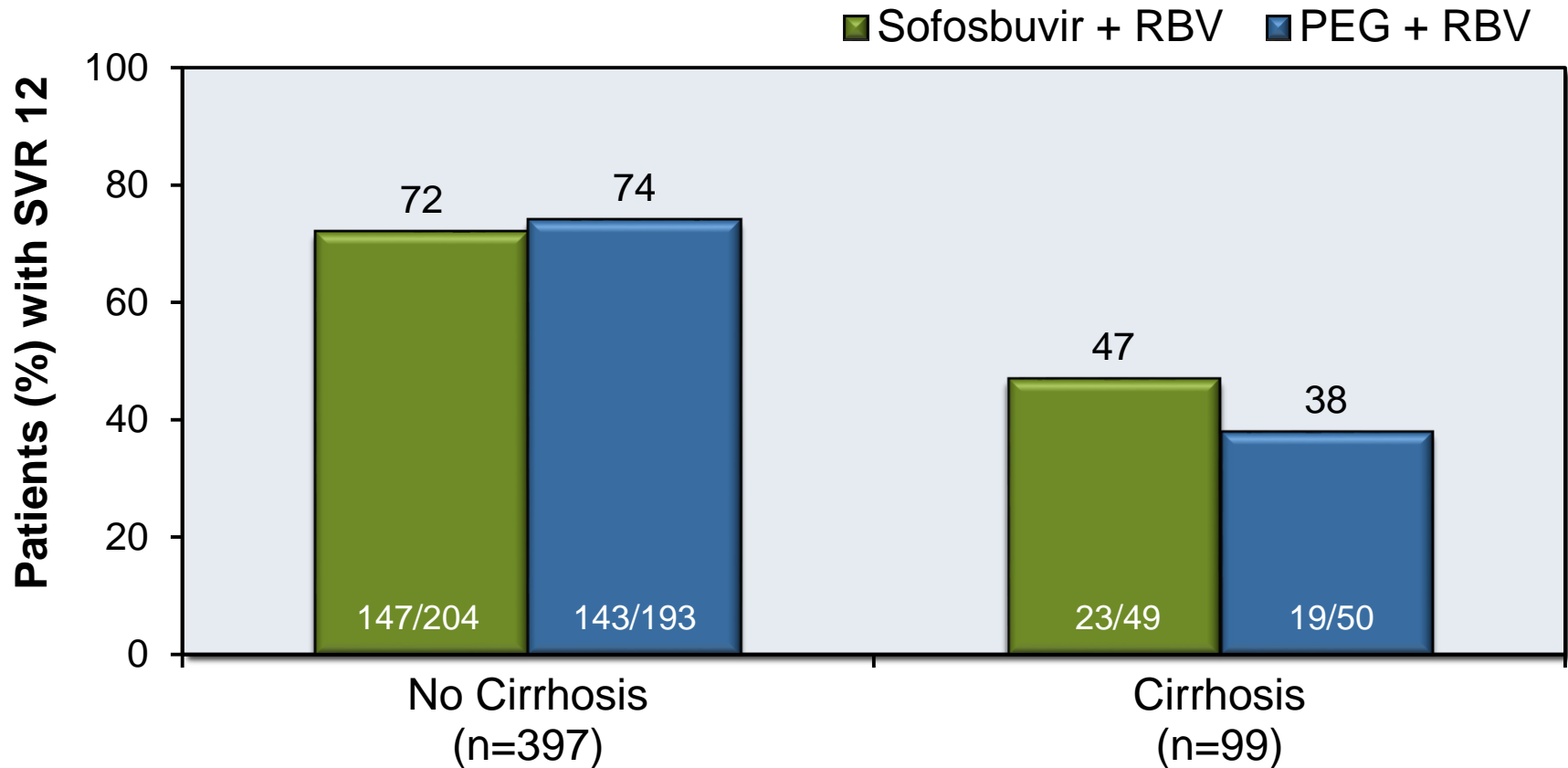

RBV = Ribavirin; PEG = Peginterferon

# Sofosbuvir + Ribavirin for Treatment-Naïve HCV GT 2 or 3 FISSION Trial: Adverse Effects

Event	Sofosbuvir + RBV (n=256)	PEG + RBV (n=243)
Discontinuation due to adverse event	3 (1%)	26 (11%)
Fatigue	92 (36%)	134 (55%)
Headache	64 (25%)	108 (44%)
Nausea	46 (18%)	70 (29%)
Pruritus	19 (7%)	42 (17%)
Hemoglobin < 10 g/dl	23 (9%)	35 (14%)
Neutropenia	0	30 (12%)
Influenza-like illness	7 (3%)	43 (18%)
Depression	14 (5.5%)	34 (14%)
Insomnia	31 (12%)	70 (29%)

# Sofosbuvir + Ribavirin for Treatment-Naïve HCV GT 2 or 3 FISSION Trial: Conclusions

**Conclusions:** “In the randomized trial of previously untreated patients with genotype 2 or 3 infection, the efficacy of the all-oral regimen of sofosbuvir plus ribavirin was similar to that of peginterferon–ribavirin, but response rates among patients with genotype 3 infection were lower than the rates among those with genotype 2 infection.”

\*Note: This conclusion pertains to both the **FISSION** and **NEUTRINO** trials, which were published in tandem



This slide deck is from the University of Washington's *Hepatitis C Online* and *Hepatitis Web Study* projects.

Hepatitis C Online

[www.hepatitisc.uw.edu](http://www.hepatitisc.uw.edu)

Hepatitis Web Study

<http://depts.washington.edu/hepstudy/>

Funded by a grant from the Centers for Disease Control and Prevention.